

First Edition 2007

Standard Specifications for Steel and Composite Structures

I General Provision, II Structural Planning, III Design



Standard Specifications for Steel and Composite Structures
I General Provision, II Structural Planning, III Design First Edition 2007

JSCE

Japan Society of Civil Engineers

Standard Specifications for Steel and Composite Structures

【 First Edition 】

I General Provision, II Structural Planning, III Design

December, 2009

Japan Society of Civil Engineers

This document is an English translation of the original Japanese text. JSCE assumes no responsibility or liability for errors or inaccuracies that may occur due to use or application of the information provided herein.

Foreword

Japan Society of Civil Engineers (JSCE) was established as an incorporated association in 1914 entrusted with the mission to contribute to the advancement of scientific culture by promoting the field of civil engineering and the expansion of civil engineering activities. Committee on Steel Structures of JSCE was reorganized in 1971 aiming to research and investigate steel materials, steel structures and composite structures, and to contribute to the progress of science and technology in a field of civil engineering. Since its establishment, the committee has organized a lot of subcommittees and they have produced a lot of outcomes related to steel materials, steel structures and their technological standards.

The internationalization of technological standards and the performance-based design are paid to attention in recent years. In the performance-based design, the improvement of transparency and accountability, the reductions of cost and negative environmental impact, and securing the quality and the performance, etc. are basic requirements. The committee resolved to make the "Standard Specification for Steel and Composite Structures" including hot technologies in 2004 as the JSCE specification does not fall behind the world trends. The specifications consist of 6 volumes. "General provision", "Basic Planning" and "Design" were published in 2007, "Seismic design" was issued in 2008, and "Construction" was also come out in 2009 in Japanese. "Maintenance" will be also appeared soon. These are the first standards by the committee on steel structures made as the performance-based design format and the limit state design method. I think that it is very meaningful to have completed the specifications using the performance-based design format at this time when a technological standard of western countries aims at the world standard.

It is expected that the contents of the specifications does not reveal only a state of the latest technology of the steel structure but also the direction of activities that the committee should aim. This English version was translated from the Japanese originals of "General provision", "Basic Planning" and "Design" of "Standard Specification for Steel and Composite Structures". I hope that the specifications will be useful and helpful for the design of steel and composite structures in the world.

Finally, warm acknowledgment is expressed to all of the members of the Sub-Committee on Standard Specification for Steel and Composite Structures and the Committee on Steel Structures for their efforts to preparation of the specifications and their invariable suggestions to the contents of the specifications.

December, 2009

MORI Takeshi

Chairman, Committee on Steel Structures
Japan Society of Civil Engineers

Preface

In 1987, the Committee on Steel Structures published two design codes based on Allowable Stress Design Method. They are "Design Code for Steel Structures PART-A: Structures in general" and "Design Code for Steel Structures PART-B: Composite structures". The newly revised above versions based on Limit State Design Method were published in 1997.

In 2000, the committee on Steel Structures organized a sub-committee for investigation of the performance-based design method. Its activity was to prepare and recommend a new design format, performance-based design for steel structures, coping with globalization. The report entitled "Towards performance-based design method for steel structures" was published in 2003. The committee on Steel Structures has recognized that the basic design format for steel structures of the next generation was established. After the publication of the above report, the committee on Steel Structures organized the sub-committee on Standard Specifications for Steel and Composite Structures in 2004. Its role is not only to incorporate latest research fruits but to publish an innovative and competitive performance-based limit state design method for steel and steel-concrete composite structures of the next generation.

It consists of 6 volumes namely "General provision", "Basic Planning", "Design", "Seismic design", "Construction" and "Maintenance". The three volumes including "General provision", "Basic Planning" and "Design", were issued in 2007. It is based on the performance-based limit state design method, and is the first time publication for the design of steel and composite structures in civil steel structural engineering field in Japan. The volume of "Design" deals with not only steel structures but also concrete slabs and steel-concrete composite girders for composite girder bridge design. Many of the provisions for steel structures are from those in "Design Code for Steel Structures PART A: Structures in General" published in 1997. Even though we seldom design composite girder bridges in Japan, hybrid structures including composite girders have been recognized to be worldwide competitive alternatives. For global competition, the provision for composite girders is inevitable. In addition to introducing the design formulae by AASHTO LRFD or EC given in PART-B, the original formulae developed by Japanese young researchers were incorporated. This is also the first time action in Japan after the publication of PART-B in 1997. I hope the revising work continues towards global-top design of the next generation.

The preparation of an English version including three volumes started in 2007 by many of code writers on a voluntary basis. First of all, I would like to express my sincere gratitude to all writers for their devoted contribution. I also have to express my sincere gratitude to JSCE Research Fund, Committee on ISO Affairs in Civil Engineering, Prof. Yoda of Waseda University and Prof. Nogami of Tokyo Metropolitan University for their financial supports on publication of the English version. I would like to give my sincere thanks to all members of the committee on Steel Structures and of the sub-committee on Standard Specifications for Steel and Composite Structures for their valuable comments.

December, 2009

NAGAI Masatsugu

Chairman, Subcommittee on Standard Specifications for Steel and Composite Structures
Committee on Steel Structures
Japan Society of Civil Engineers

Committee for Steel structures

Adviser : Abe H., Ito M., Usami T., Kato M., Kuranishi S.,
Sakai H., Nishimura N., Watanabe E.

Chairman : Mori T.

Vice-chairman : Takagi S.

Secretary general : Sasaki Y.

Member

Ikuma M.,	Igarashi H.,	Ichikawa A.,	Iwasaki E.,	Iwanami M.,
Echigo S.,	Oga M.,	Ogaki K.,	Ota K.,	Otori Y.,
Okamoto T.,	Ogawa A.,	Okui Y.,	Oshita S.,	Ono K.,
Kainuma S.,	Kasuga A.,	Kamihigashi Y.,	Kaneko S.	KItada T.,
Kiyomiya O.,	Sakai S.,	Keira K.,	Goto Y.,	Konishi T.,
Sakano M.,	Shito K.,	Sugimoto I.,	Sugiura K.,	Sugiyama T.,
Sumi M.,	Tachibana Y.,	Tatsumi T.,	Tateishi K.,	Tanaka M.,
Nagai M.,	Nakazawa M.,	Nakajima A.,	Naganuma T.,	Nara S.,
Nishikawa K.,	Nogami K.,	Nozawa S.,	Hayashikawa T.,	Hirabayashi Y.,
Fukada S.,	Fujii K.,	Fujino Y.,	Fujiwara H.,	Hotta T.,
Honma K.,	Maekawa K.,	Masuda N.,	Miki C.,	Murakami S.,
Murakoshi J.,	Mori K.,	Yaginuma Y.,	Yamaguchi E.,	Yamaguchi T.,
Yamamoto H.,	Yukawa M.,	Yoda T.		

: Organizer

Sub-committee for Standard Specifications for Steel and Composite Structures

Chairman : Nagai M.

Secretary general : Yamaguchi E.

Member

Ikuma M.,	Ito N.,	Suzuki E.,	Hakamada F.,	Abe M.,
Ichikawa A.,	Inokuma Y.,	Iwakuma T.,	Usami T.,	Okamoto T.,
Ogaya S.,	Okui Y.,	Ono K.,	Kitada T.,	Goto Y.,
Sakano M.,	Sugiura K.,	Sugiyama T.,	Sumi M.,	Takagi S.,
Tateishi K.,	Tamaoki T.,	Nara S.,	Nishimura N.,	Nogami K.,
Nozawa S.,	Hayashikawa T.,	Hino S.,	Hujino Y.,	Hotta T.,
Miki C.,	Murakoshi J.,	Mori T.,	Yamamoto H.,	Yoda T.,
Yokota H.,	Watanabe E.,	Park Y.S.,	Kyung K.S.,	Ha D.H.*

: Organizer

* : Observer

Sub-committee for Standard Specifications for Steel and Composite Structures

General Provision WG

Chairman : Sugiyama T.

Member

Ikeda M., Ichikawa A., Usami T., Okui Y., Nishimura N.,
Nogami K., Mori T., Yamaguchi E.

Structural Planning WG

Chairman : Ichikawa A.

Member

Ikeda H., Ikeda M., Ito A., Ogaki K., Ono K.,
Katsuchi H., Sugiyama T., Takagi S., Hosaka T., Hota T.,
Morino M., Yamamoto H., Yokota H.

old member : Inokuma Y.

: Organizer

Design WG

Chairman : Yoda T.

Secretary general : Nogami K.

Member

Akimoto R., Arima N., Iura M., Ikariyama H., Ikeda M.,
Ishikawa T., Uchida D., Urata M., Ota M., Ota K.,
Ogaki K., Okada J., Okui Y., Kainuma S., Kawabata A.,
Kitahara T., Kumagai Y., Sato N., Saito N., Suzuki S.,
Sugiyama T., Tanaka K., Tanaka C., Tsuruta H., Nakazawa M.,
Nakasu K., Nakahara T., Nakamura S., Nakamura S., Nagai M.,
Huruya N., Maeda K., Miura Y., Minami K., Murakami M.,
Murakami S., Yanagawa H., Yabuno M., Yamaguchi E., Yamaguchi T.,
Yoneyama H.

old organizer : Ikeda D.

: Organizer

Sub-committee for Standard Specifications
for Steel and Composite Structures

Writing author of Design WG

Chapter 1, 2	Sugiyama T.*, Akimoto R.** , Ikeda M., Urata S.
Chapter 3, 5	Nakamura S.* , Okada J.** , Okui Y., Huruya N.
Chapter 4, 6	Yamaguchi E.* , Ishikawa T.** , Akimoto R., Iura M., Saitou N., Tanaka K., Nakazawa M., Murakami S., Yamaguchi T.
Chapter 7	Kitahara T.* , Urata M.** , Ota M., Yoneyama H.
Chapter 8	Kainuma S.* , Minami K.** , Tsuruta H.
Chapter 9	Sugiyama T.* , Akimoto R.** , Kitahara T., Yoneyama H.
Chapter 10, 12	Saitou N.* , Yabuno M.** , Iura M., Ishikawa T., Tanaka K., Miura Y., Murakami M.
Chapter 11	Yamaguchi T.* , Miura Y.** , Nakamura S., Minami K.
Chapter 13	Murakami S.* , Murakami M.** , Kitahara T., Nakazawa M., Nakamura S.
Chapter 14	Kawabata M.* , Ikariyama H.** , Nakamura S., Ota K., Uchida D., Tanaka C., Nakahara T., Suzuki S., Akimoto R.
Chapter 15	Okui Y.* , Ota M.** , Okada J., Huruya N., Yabuno M., Nagai M., Nakamura S., Nogami K.

* : Chief

** : Organizer

: Member who translated into English

Volume I General Principles

Standard Specifications for Steel and Composite Structures 【 General Principles 】

Contents

Chapter 1 General	1
1.1 Fundamental Philosophy	1
1.2 Composition	1
1.3 Scope	2
1.4 Documents concerning Design, Construction and Maintenance	3
1.5 Meanings of Descriptive Words and Clauses in These Specifications	4
1.6 Ability and Responsibility of Engineers	4
1.7 Check at Structural Plan and Design Stages	5
1.8 Terms and Definitions	5
Chapter 2 Basis for Structural Planning, Design, Construction and Maintenance ...	10
2.1 Purpose of Structural Planning, Design, Construction, and Maintenance	10
2.2 Verification of Performance	11
2.3 Performance Level and Importance of Structure	14

Chapter 1 General

1.1 Fundamental Philosophy

The fundamental philosophy of these specifications is that performance verification methods shall be applied to all of structural plan, design, construction, and maintenance of steel and composite structures and engineers' ethics shall be observed at every stage.

【commentary】

These Standard Specifications for Steel and Composite Structures are based on performance verification methods in which the required performance of a structure is specified first and then actual performance is verified at all stages: structural planning, design, construction and maintenance. Consequently, the fundamental philosophy behind these specification is that performance verification methods should be applied at the structural planning, design, construction, and maintenance stages of steel and composite structures, while fully observing engineering ethics at every stage. Within these specifications, the actual articles relating to the observance of engineering ethics can be considered the following: ① accountability for structural planning, design, construction, and maintenance work; ② traceability of reasons for decision-making after the fact; and ③ compliance. Currently, some performance requirements of structures are not explicitly verified, so some parts of the specifications are not fully complete.

1.2 Composition

These specifications are composed of six volumes; that is, General principles volume, structural plan one, design one, seismic design one, construction one, and maintenance one.

【commentary】

The six volumes of these specifications apply to the structural planning, design, construction, and maintenance of structures.

A structure's various performance requirements should be upheld throughout the design working life of the structure and this must be confirmed. It is necessary to succeed to the information relating to "performance requirements and methods of achieving them" and/or "purpose and achievement method" at each stage of structural planning, design, construction, and operation and maintenance to the next stage certainly. That is, all stages should correlated with each other closely as shown in Fig.C1.2.1. At the structural planning and design stages, assumptions are made about the type and size of structure and then the performance level required of this assumed structure is verified. Immediately after construction is completed, it should be checked whether this required performance level is satisfied or not. At the maintenance stage, the performance level of the in-service structure is estimated based on information collected through inspections, because the performance level of a structure generally decreases over time. Based on this estimate, a judgment as to the structural soundness of the structure - that is, whether the performance level of the structure is equivalent to or exceeds the a priori determined required performance - is made and the result is later fed back into the operation and maintenance plan.

As noted above, checking and confirmation of the performance level of a structure continues through all stages of structural planning, design, construction, and operation and maintenance. Thus, these specifications include five volumes corresponding to structural planning, design, construction, and maintenance of structures, respectively. It should be noted that design is separated into a Design volume and a Seismic Design volume. This is because it is generally recognized that design philosophy and verification techniques relating to seismic design are different from those of other areas of structural design and that a separate explanation of seismic design may be convenient for design engineers.

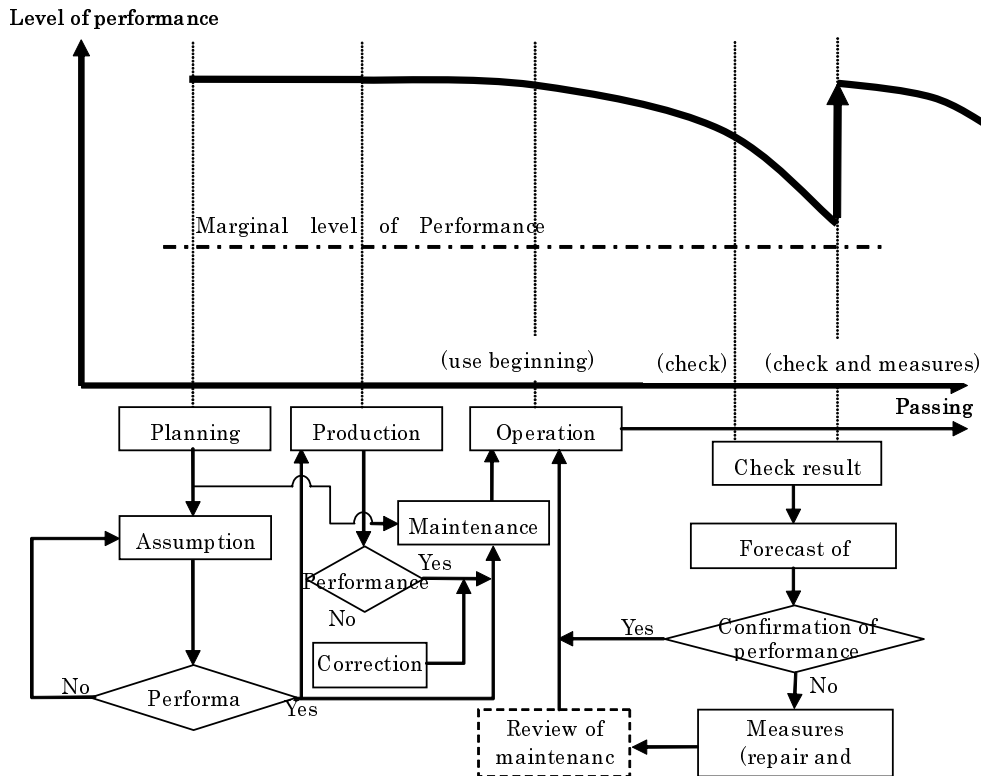

Fig.C1.2.1 Performance of structure during its life cycle

1.3 Scope

These specifications shall be applied to the structural plan, design, construction, and maintenance of steel structures, composite girders, and composite columns (described as "steel and composite structures" hereafter).

【commentary】

These specifications apply to the structural planning, design, construction, and maintenance of steel structures, composite girders, and composite columns filled with concrete. Composite columns are treated explicitly only in the Seismic Design volume. The structures considered in these specifications are general steel structures in which structure of the main members consists of steel and composite girders and columns composed of both steel and concrete. As for composite girders, references [JSCE 2002a] and [JSCE 2002b] may be referred to instead of these specifications.

Highway and railroad bridges are the main focus of these specifications, although port and harbor structures, river structures, and electric power facilities are also considered. Each of these structure

types also has its own specifications or standards for planning, design, construction, and maintenance. However, as each of these specifications or standards is codified for a specific type of structure, there is some possibility of difficulty in attempting to plan, design, construct, and maintain a specific structure that does not have a specific applicable specification or standard. Here, not only are the normal techniques for structural planning, design, construction, and maintenance relating to specific steel and composite structures such as highway and railway bridges specified, but their applicability to the other structures is also considered.

Where the articles of these specifications are insufficient and/or inappropriate for dealing with the structural planning, design, construction, and maintenance of a specific individual structure type, it may not be necessary to apply these specifications if the effectiveness, appropriateness, accuracy, and applicable scope of another selected technique can be certified. Even in this case, however, the structural planning, design, construction, and maintenance of the structure may be implemented while taking account of the substance of these specifications.

1.4 Documents concerning Design, Construction and Maintenance

- (1) Design documents, drawings, construction procedure documents, maintenance documents, and other relevant documents shall include the description that compliance with relevant regulations has been fulfilled at every stage of structural plan, design, construction, and maintenance. These documents also shall be lodged.
- (2) Design documents, drawings, construction procedure documents, maintenance documents, and other relevant documents shall be presented in an appropriate manner satisfying the requirements for official information and/or documents. In case that required items are not shown, these documents should be made based on the rules such as Japanese Industrial Standards.

【commentary】

As already noted, the fundamental philosophy of these specifications is that performance verification methods should be applied to the structural planning, design, construction, and maintenance stages of steel and composite structures with full observance of engineering ethics at every stage. Given this, full attention should be paid to the following points when producing design, construction, and maintenance documents.

- ① The design document should describe and give the reasons for selecting particular structural types, structural materials, construction methods, etc. at the structural planning and design stages. (The accountability requirement)
- ② In cases where the articles of these specifications are not applied, the engineering justification of the appropriateness of this decision relating to the performance verification method should be explained in the design document. If a newly developed performance verification approach is adopted, both the title of the third party institution that has certified the appropriateness of the new method and the results of certification should be provided in the design document. Moreover, construction documents should be prepared so as to ensure that construction work satisfies all of the performance requirements of the design stage.
- ③ In cases where structural types, structural materials, construction methods, etc. are determined through consultation among the persons concerned and/or on the direction of the owner because of the absence of specific requirements, not only should details of the determinations (including the decision-making process) be written down in design, construction, and maintenance documents, but also the names of participants in the consultation and/or the director(s). (The

traceability requirement)

1.5 Meanings of Descriptive Words and Clauses in These Specifications

Meanings of descriptive words and clauses in these specifications are classified as shown in Table 1.5.1.

Table 1.5.1 Meanings of descriptive words and clauses

Meanings of descriptive words and clauses	General examples for descriptive words and clauses
【Requirement】 items that shall be necessarily satisfied according to these specifications	~ shall (be) ~ should (be) ~ is to (be)
【Recommendation】 item that might be the most commendable among several alternatives	~ shall preferably (be)
【Possibility】 item that is one of the acceptable alternatives	~ may (be)

【commentary】

In order to ensure that the meaning of each article is clear, the phrasing used in these specifications is classified largely into the three categories shown in Table 1.5.1. This classification has been adopted with reference to [JSCE 2003] and [Japan Highway Agency 2002].

1.6 Ability and Responsibility of Engineers

- (1) The engineers who take part in the structural plan, design, construction, and maintenance of steel and composite structures shall be the experts in the relevant field.
- (2) The engineers who take part in the structural plan, design, construction, and maintenance of steel and composite structures may be desirable to be the persons qualified by the public agencies in the relevant field.
- (3) The engineers who take part in the structural plan, design, construction, and maintenance of steel and composite structure shall be responsible for ensuring of public safety and benefit, preservation of environment, and so on.
- (4) The engineers who take part in the structural plan, design, construction, and maintenance of steel and composite structure shall have accountability for both decision making results and evidence of performance-based verification.

【commentary】

This article prescribes the skills required of engineers who take part in the structural planning, design, construction, and maintenance of steel and composite structures as well as their responsibilities. The quality of structural planning, design, construction, and maintenance outcomes depends generally on the skills of the engineers involved in these activities, because they often have to make decisions based on their technical knowledge and/or experiences at every stage of structural planning, design, construction, and maintenance. Consequently, engineers who carry out the structural planning, design,

construction, and maintenance of steel and composite structures should be experts with experience in the relevant fields. In other words, the engineers should preferably be persons certified in the relevant field by public agencies such as the Japan Society of Civil Engineers, the Institution of Professional Engineers Japan, and so on.

The structures of greater safety, economy, and durability structure can be planned, designed, constructed, and maintained through the contribution of skilled and experienced engineers in the relevant field.

The design, construction, and maintenance documents produced according to Article 1.4 should be lodged appropriately by the engineers involved in structural planning, design, construction, and maintenance so that everyone can refer to the adopted standards, references, minutes, etc. throughout the durable lifetime of a structure.

1.7 Check at Structural Plan and Design Stages

An appropriate check shall preferably be made in order to ensure the required technological level and quality of structural plan and design.

【commentary】

So as to ensure that a structure is of the required quality, appropriate reviews of whether the structural types, structural materials, and structural details adopted at the structural planning and design stages are reasonable and whether adequate performance verification is taking place should preferably be carried out by an authorized third-party institution. If no such institution is yet available, it is acceptable for these reviews to be carried out by another design company.

1.8 Terms and Definitions

The terms used commonly in these specifications are defined as follows.

- (1) General terms relating to structural plan, design, construction, and maintenance
 - 1) Performance-based design method: design method in which no restrictions are applied to the structural types and materials, design methods, construction methods if the designed structure has only to keep the required performance level. In other words, design method in which the specified performance of the structure may be ensured at every stage of structural plan, design, construction, and maintenance once the objective and function of structure is defined clearly and the performance of structure is specified so as to fulfill its function.
 - 2) Regulation-based design: design method in which structures or structural members are designed based on the specific design codes where the proper procedures such as design calculations, the kind of structural materials and their size, etc. are specified.
 - 3) Deemed-to-satisfy regulation: regulations in which one or more of solutions that are considered to satisfy the required performance is illustrated. These regulations may be adopted in case that verification method of structural performance is not necessarily specified. The kind of structural materials and their size, the procedures such as design calculations that have been regarded as proper empirically, etc. are specified in these regulations.
 - 4) Reliability-based design method: design method in which the possibility that structures/structural members lead to limit states is estimated based on the probabilistic

theory.

- 5) Limit state design method: design method in which limit states to be verified is specified clearly and partial factor design format is adopted as the verification format. Partial factor design format is classified into Level 1 verification format from the reliability-based design viewpoint. Strictly speaking, partial factor design format is not equivalent to limit state design method although both are sometimes regarded equivalent in Japan.
 - 6) Partial factor design format: design format in which some partial factors are incorporated in order to consider the uncertainties or scatter relating to actions, geotechnical parameters, size of structural members, structural analysis methods, etc..
 - 7) Life cycle cost: the total amount of cost that is spent for structural plan, design, construction, maintenance, and demolition of structure; in other words, the total amount of cost invested during the life cycle of structure.
 - 8) Design working life: assumed period for which a structure is to be used for its intended purpose without major repair being necessary. During design working life, originally planned regular inspection and repair are continued. Design working life is determined at design stage.
 - 9) Durable lifetime: the period from the service start to a point in time when the performance of structure becomes down due to fatigue, corrosion, material deterioration, etc. and structure leads to its limit states.
 - 10) Objective: commonly used expression of the reason why the structure is constructed. It may be desirable that the objective is expressed by using the word such as client/user as the subject.
 - 11) Basic requirements: the clauses to be observed relating to the use and function of structure, environmental conservation, and safety of work. These clauses relating to the required size/space and acts such as design and construction, etc. are enacted based on the relevant laws.
 - 12) Function: the role that structure has to play in accordance with its objective.
 - 13) Check: the conduct that is carried out by a authorized third party institution in order to scrutinize whether the design process compounded from determination of objective to verification is proper or not.
 - 14) Authorization: determination of the third party that is able to perform the check.
 - 15) Certification: act that the authorized third party institution checks the structural design and issues the certificate if the design is proper.
- (2) Terms relating to performance
- 1) Performance: ability that the structure has to demonstrate in accordance with its objective or requirements.
 - 2) Required performance: performance that the structure has to keep in order to achieve its objective.
 - 3) Performance item: item into which the required performance is subdivided. One verification index to which one limit state generally corresponds is determined to each performance item.
 - 4) Performance level: the level of performance that is required to each structure. Performance level is determined for each required performance depending on its necessity.
 - 5) Safety: ability of a structure to ensure the lives and assets of users and the third party.
 - 6) Serviceability: ability of a structure to perform adequately so that the users do not perceive any intolerable unpleasantness or unease.
 - 7) Durability: ability of a structure or structural element to resist the deterioration caused by repeating variable action and/or environmental action. In case of steel and com-

posite structures, corrosion of steel members caused by environmental action, fatigue phenomenon caused by repeating variable action, and material and strength deterioration of concrete members are considered.

- 8) Repairability: ability of structure to be restored to the originally specified performance level when intended actions attacks structure and then its performance level may decrease.
 - 9) Societal and environmental compatibility: ability of structure not only to contribute to the sound societal, economic, cultural, etc. activities but also to minimize the infection upon the surrounding social and natural environment.
 - 10) Constructibility: ability to keep construction work safe and certain during fabrication and erection.
 - 11) Initial soundness: ability of structure that its performance just after completion is not below the level intended at design stage.
 - 12) Maintainability: easiness of maintenance of structure.
- (3) Terms relating to limit state
- 1) Limit state: a state beyond which the structure or structural element no longer satisfies the required performance.
 - 2) Safety limit state: a state associated with collapse, or with other similar forms of structural failure caused by large deformation, large displacement, vibration, etc.. Safety limit state is used as the limit state corresponding to the structural safety. The words "ultimate limit state" are adopted in Seismic Design Volume as this expression often used instead of "Safety limit state".
 - 3) Serviceability limit state: a state that corresponds to conditions beyond which specified service requirements for a structure or structural element are no longer met. Serviceability limit state is used as the limit state corresponding to the serviceability.
 - 4) Repair limit state: a state which corresponds to conditions beyond which repair of structure is not possible with current applicable repair technology, with reasonable cost, nor within reasonable period and structure is not able to be under service. Repair limit state is used as the limit state corresponding to the repair easiness. In Seismic Design Volume, the words "Damage limit state" is adopted instead of "Repair limit state".
 - 5) Fatigue limit state: a state associated with fatigue failure of structure or structural member caused by repeating variable action. Fatigue limit state is used as the limit state corresponding to the fatigue durability.
- (4) Terms relating to verification
- 1) Performance verification: activities performed in order to verify if the designed structure satisfies all of the performance requirements or not. In case that limit state design method is adopted, judgment is made by comparing response value S with limit value of performance R .
 - 2) Verification index: index to express a performance item as a physical quantity. Verification indices are utilized in performance verification. .
 - 3) Response value (Demand) S : physical quantity caused in the structure by action.
 - 4) Limit value of performance (Capacity) R : allowable limit physical quantity towards corresponding structural response. This value is determined based on required performance level.
 - 5) Statistical characteristic value: a value corresponding to a priori specified fractile of the statistical distribution of random variable such as material property and action. Expected value and mode of random variable are regarded as statistical characteristic

values.

- 6) Optimization: activities performed in order to obtain an optimal solution so that the objective function including the required performance, performance item, etc. as the subordinate variables may take the smallest or the largest value under some restraint conditions.
 - 7) Partial factor: a factor assigned to each design value in order to consider its uncertainty. Five partial factors, i.e. action factor, material factor, factor for structural analysis, factor for structural member, and factor for structure are generally adopted.
 - 8) Factor for structure: a factor in order to consider the importance of structure, societal and economic influence caused by the failure of structure, and so on.
- (5) Terms relating to actions
- 1) Action: all causes which draw deformation, displacement, constraint, and deterioration of structure or structural element.
 - 2) Load: an assembly of mechanical forces directly acting on a structure which are converted from actions through the analytical model. Load is used as an input datum for design calculation of stress resultant, stress, displacement, and so on.
 - 3) Design value of action: a value obtained by multiplying the action factor to the characteristic value of corresponding action.
 - 4) Direct action: an assembly of concentrated or distributed mechanical forces acting on a structure.
 - 5) Indirect action: the cause of deformations imposed on the structure or constrained in it.
 - 6) Environmental action: mechanical, physical, chemical or biological action which may cause deterioration of the materials constituting a structure.
 - 7) Permanent action: action which is likely to act continuously throughout a given reference period and for which variations in magnitude with time are small compared with the mean value.
 - 8) Variable action: action for which the variation in magnitude with time is neither negligible in relation to the mean value nor monotonic.
 - 9) Primary variable action: one or one set of variable actions considered as the most primary one in case that load combination is taken into account in performance verification activities.
 - 10) Subsidiary variable action: a action which is considered as the subsidiary one among variable actions and which is additionally combined with the combination of primary variable action and accidental action.
 - 11) Accidental action: action that is unlikely to occur with a significant value on a given structure over a given reference period and which may cause a serious damage for a structure if once occurs.
 - 12) Action modifying factor: a factor to convert the standard or nominal value of action into characteristic value.
 - 13) Action factor: a factor to consider the unfavorable deviation of statistical characteristic value of action, uncertainty relating to action model, change of action characteristics during a given reference period, the influence of action characteristics on the relevant limit state of structure, variation of environmental action, and so on.
- (6) Terms relating to structural materials
- 1) Characteristic value of material strength: a value corresponding to an a priori specified fractile of the statistical distribution of material strength. Statistical distribution is determined based on the statistical data which are obtained from the standardized

- material strength test.
- 2) Standard value of material strength: a value of material strength adopted in other structural design specifications/standards except "Standard Specifications for Steel and Composite Structures".
 - 3) Material strength modifying factor: a factor to convert the standard value of material strength into characteristic value.
 - 4) Material factor: a factor to consider the unfavorable deviation of statistical characteristic value of material strength, the difference of material properties between experiment specimen and real structure, the influence of material properties on the relevant limit state of structure, change of material properties during a given reference period, and so on.
 - 5) Design value of material strength: a value obtained by dividing the characteristic value of material strength by the corresponding material factor.
- (7) Terms relating to calculation of response value
- 1) Factor for structural analysis: a factor to consider the accuracy of structural analysis methods which are applied in the calculation of stress resultant, etc, the uncertainties relating to modeling procedure of structure, and so on.
 - 2) Design value of response: a value obtained by multiplying the factor for structural analysis to the response value. Response value is calculated by using the values of actions which are multiplied by their corresponding action factors.
- (8) Terms relating to calculation of limit value of performance
- 1) Factor for structural member: a factor to consider the accuracy of structural resistance analysis methods which are applied in the calculation of load-carrying capacity, variation of structural member size, importance of the role of structural member, and so on.
 - 2) Design limit value of performance: a value obtained by dividing the limit value of performance by the factor for structural member. Limit value of performance is calculated by using the design values of strength materials.

【Commentary】

Terms commonly used in these specifications are defined based on [JSSC 2001], [JSCE 2003], and so on. Terms peculiar to each volume are defined in the relevant volume.

As for the term "Safety limit state" as specified in (3) 2), it is used here to clarify the relation between required performance and the relevant limit state; the term "Ultimate limit state" is commonly used instead of this term. The term "Safety limit state" is adopted in these specifications because it incorporates the concept of public safety, durability in a broad sense, initial soundness, etc. in addition to the idea of "Ultimate limit state" in the Design volume.

References in Chapter 1

- Japanese Society of Steel Construction (2001) : Performance design guidelines for Civil Engineering Steel Structures, JSSC Technical Report No. 49.
- Japan Society of Civil Engineers (2002a) : Standard Specification for Concrete, Volume of Structural Performance Verification .
- Japan Society of Civil Engineers (2002b) : Guidelines for Performance Verification of Hybrid Structures (tentative) .
- Japan Road Association (2002) : Specifications for Highway Bridges and Commentary, I Common Specifications Volume, II Steel Highway Bridges Volume .
- Japan Society of Civil Engineers (2003) : Comprehensive Design codes (tentative) code PLATFORM ver.1 .

Chapter 2 Basis for Structural Plan, Design, Construction and Maintenance

2.1 Purposes of Structural Plan, Design, Construction and Maintenance

After the most suitable kind and type of structure are selected and the outline of its dimensions are determined at the structural plan stage, steel and composite structures shall satisfy all of the required performances such as safety, serviceability, durability, repairability, societal and environmental compatibility, etc. at every stage of design, construction, and maintenance throughout a given reference period.

【commentary】

Steel and composite structures should be fit for purpose and should not only be safe but also functional. Therefore, once an appropriate plans for steel and composite structures (or structural members) have been developed, they should be designed, constructed, and maintained so as to ensure adequate safety against various actions and to be functional during their construction and service periods. Steel and composite structures should also be durable and compatible with their surroundings.

For example, bridges are constructed to allow roads, railways, etc. to cross rivers, straits, roads, and railways and so that persons and goods can be transported over them. Although the most important performance requirement for bridges is structural safety, it is also important to secure good structural durability to ensure the long-term structural soundness of the bridge. Furthermore, bridges should be acceptable to nearby residents and should not affect those residents with uncomfortable vibration and/or noise radiation that may be caused by the passage of vehicles over them. A further requirement is that bridges should have excellent aesthetic qualities.

At the structural planning stage, a bridge should be compatible with its purpose, while ①legal restrictions on the use and function of the bridge and also ②economic efficiency should be considered. The performance requirements, meaning ③safety, ④serviceability, ⑤durability, ⑥social and environmental compatibility, ⑦earthquake influence, ⑧constructability, and ⑨maintenance, should also be discussed at the structural planning stage. Multiple alternatives with respect to structural type should be compared and discussed based on a consideration of the above-mentioned performance requirements in order to determine the optimal type.

At the structural design stage, comparison and discussion of various matters such as structural material selection, corrosion protect method, determination of cross sections, etc. is carried out. Although these comparisons and discussions are based on economic efficiency, the optimal alternative should be determined not from the viewpoint of minimum initial construction cost but rather in consideration of minimum life-cycle cost. In other words, ease of maintenance should be taken into account so as to ensure that the bridge is durable as a semi-permanent structure.

The design working life of a structure can be considered from three points of view, as follows:

- a) economic working life corresponding to economic life according to asset depreciation;
- b) functional working life corresponding to the period until the structure fails to fulfill its socially expected function;
- c) physical working life corresponding to the absolute end when the structure itself malfunctions.

In structural design, it is generally assumed that the physical working life is greater than the other

two measures of working life

Minimizing the life-cycle cost means that economic efficiency is investigated through consideration of both economic working life and physical working life. No quantitative estimation method has yet been established for doing this, although society has recently come to expect the establishment of such a method. The term "functional working life" represents the time until the structure is considered useless because of changing social and economic activity. Taking account of the present level of structural engineering development, it may be impossible to determine this functional working life. However, structures should be designed so that the physical working life is longer than any predicted functional structural life. Design working life is set in the range 60 to 100 years in the current design specifications for highway and railway bridges. As many existing bridges have been in service for more than 100 years, design working life is generally established as 100 years at present.

2.2 Verification of performance

- (1) At every stage of structural plan, design, construction, and maintenance, required performances of steel or composite structure shall be determined definitely. In general, safety, serviceability, durability, repairability, societal and environmental compatibility are to be required as required performances.
- (2) At the design stage, performance level shall be shown against each of performance item which corresponds to the relevant required performance and performance verification shall be carried out for every performance item.
- (3) In the performance verification of steel and composite structures, verification indices and their corresponding limit values of performance shall be determined first, and then the check whether structural response value obtained through an appropriate numerical analysis method is less than or equal to the limit value of performance is to be carried out in general.
- (4) Confirmation through experiments, etc. or observance of regulations relating to structural types, structural materials, etc. may be substituted for the verification method described in the above (3).
- (5) At the structural plan and design stages, verification shall be performed so that response value is less than or equal to the limit value of performance throughout both construction period and working life. Specific verification methods are illustrated in Structural Plan Volume, Design Volume, and Seismic Design Volume.
- (6) At the end of construction stage, just completed structure shall fulfill the all of required performances considered in its design. Specific verification methods are illustrated in Construction Volume.
- (7) During working life of structures, an appropriate inspection or examination method, a proper countermeasure against damage, etc. shall be selected so as to satisfy all of the required performances. Specific verification methods are illustrated in Maintenance Volume.

【commentary】

- (1) The first step at the structural planning and design stages is to determine the required performance of the steel or composite structure. However, there remain at present various opinions and arguments regarding the definition and classification of required performance; as yet, no consensus on these matters has been reached.

In [Ministry of Land, Infrastructure, Transport and Tourism (2002)], three performance requirements - that is, safety, serviceability, and restorability - are defined as the fundamental required performance of a structure. These three are subdivided according to the function of

the structure. In the subdivisions, the performance requirement "durability" occurs commonly. It is very important for the durability of a steel or composite structure to be ensured at every stage of structural planning, design, construction, and maintenance, because the physical working life of the structure is significantly affected by how deterioration of structural performance with time under repeated variable actions and/or environmental actions is controlled. For this reason, durability is defined as one of the performance requirements in these specifications.

Social and environmental compatibility is a recent requirement associated with changing social and economic circumstances. This new fundamental performance requirement may become crucial from now on, although techniques for defining and estimating the relevant limit state are inadequate at present [JSCE (2003)].

Further, performance during the construction stage is to be carefully considered at every stage of structural planning, design, and construction. This performance requirement is defined as "workability" and is regarded as one of the performance requirements in these specifications.

In summary, the performance requirements adopted in these specifications are safety, serviceability, durability, restorability, social and environmental compatibility, and workability. Table C2.2.1 shows the performance items corresponding to each performance requirement. These performance requirements and performance items are applicable not only to structural planning and design but also to the maintenance of structures in service.

- (2) When verifying performance requirements at the design stage of steel and composite structures, it is usual to verify whether the designed structure will reach each of the limit states corresponding to the a priori established level of required performance. The term "limit state" means the state assumed as the extreme margin of each performance item (the itemized of performance requirements). This means that, if each of these limit states is clearly established, performance verification based on the limit state design method is possible. The performance items and their corresponding limit states are prescribed in each volume.

The basis of performance verification according to performance-based design in these specifications is that the design value of demand, S , should be less than the design value of capacity, D , for every performance item, where both S and D are calculated using partial factors. Fig.C2.2.1 illustrates the framework for performance verification. In cases where it is not possible to establish a limit state, performance verification is carried out by optimizing an objective function such as cost, utility, etc., which is a function of the design variables [JSCE (2001)].

At present, it is possible to establish relevant limit state(s) for some performance requirements. For others, it is not easy to do so. For the former, performance verification is carried out quantitatively. On the other hand, in the latter case, optimization of the objective function is attempted instead of a quantitative performance verification.

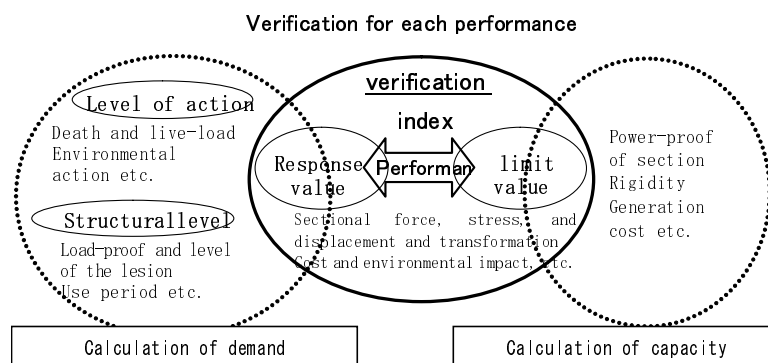

Fig.C2.2.1 Framework of performance verification

- (3) In calculating response values, it is necessary to choose a structural model as well as a structural

Table C2.2.1 Examples of performance requirements of structures and related performance items in these specifications

Performance requirement	Performance item	Example of check item	Handling with book			
Safety	Structural safety	resistance of structural member, resistance of whole structure, stability, deformation performance, etc.	Structural planning volume	Design volume	Maintenance volume	
	Public safety	injury to users and third parties (falling objects etc.)				
Serviceability	Vehicle operating performance	vehicle operating performance under usual conditions (soundness and rigidity of road)		Design volume		
		train operating performance and ride comfort under usual conditions				
	Pedestrian comfort	pedestrian comfort under usual conditions (walking-induced vibration)				
Restorability	Restorability after earthquake	level of damage (ease of restoration)				
Durability	Fatigue resistance	fatigue durability against variable actions		Design volume		
	Corrosion resistance	rust prevention and corrosion protection performance of steel material				
	Resistance to material deterioration	concrete deterioration				
	Maintainability	ease of maintenance (inspection, painting, etc.) and ease of restoration				
Social and environmental compatibility	Social compatibility	appropriateness of partial factor (consideration of social importance of structure)	Design volume			
	Economic rationality	social utility during life cycle of structure				
	Environmental compatibility	noise, vibration, environmental impact (CO ₂ emissions), aesthetics, etc.				
Workability	Safety during construction	safety during construction	Design volume · Construction volume			
	Initial soundness	material quality, welding quality, etc.				
	Ease of construction	ease of fabrication and construction work				

analysis method that estimate structural performance appropriately. Many highly advanced structural analysis methods are available now as a result of remarkable development in computer techniques in recent times, so the most appropriate method should be chosen corresponding to the type of structure and the aim of performance verification. Note that it is essential to appropriately model action loading and structural type in order to obtain really accurate solutions, even if this means adopting a highly advanced structural analysis method. Furthermore, the results obtained should be properly investigated and utilized.

- (4) Where it proves difficult to calculate response values using a numerical analysis method and/or to establish suitable limit states, experimental confirmation or verification of compliance with regulations relating to the structure type, structural materials, etc. may be carried out instead of a performance verification.
- (5) At the structural planning and design stages, it should be verified that the response value is less than or equal to the limit value of performance throughout the construction period and the

structure's working life. That is, verification includes not only safety, serviceability, restorability, durability, and social and environmental compatibility but also the performance requirements for the construction and maintenance stages. Workability is the construction stage performance requirement relating to safety during construction, ease of fabrication and construction work, etc. It is one of the most important aspects of performance that requires consideration at the structural planning and design stages.

Maintainability, relating to the ease of maintenance of a structure, is also an important performance requirement that should be considered at the structural planning and design stages. In Chapter 8 "Maintenance" of the Structural Planning volume, considerations relating to the need for and arrangement of maintenance systems and matters such as avoiding of structural details that hinder maintenance, etc., are prescribed. In the Design volume, "maintainability" is considered one of the performance items relating to performance requirement "durability" because the former is closely related to the latter. At the design stage, ease of inspection and repainting, ease of damage restoration, etc. are discussed.

Specific verification methods are illustrated in the Structural Planning volume, the Design volume, and the Seismic Design volume.)

- (6) At the construction stage, the performance requirement "workability", including such performance items as safety during construction, securing structural quality, etc. needs to be satisfied. In particular, since the quality of construction can greatly influence the performances of a structure in service, it is important to satisfy the requirements for the initial soundness of the structure [JSCE (2003)]. Specific verification methods are illustrated in the Construction volume.
- (7) The performance required at the maintenance stage may be approximately the same as that required at the structural planning and design stages. It should be ensured that the maintenance stage performance requirements are satisfied throughout the working life of the structure by implementing appropriate measures such as periodical inspections, detailed investigations, and repair and/or reinforcement according to demand. Specific verification methods are illustrated in the Maintenance volume.

2.3 Performance Level and Importance of Structure

Performance level shall be determined for each of required performances corresponding to safety, serviceability, durability, repairability, societal and environmental compatibility. Performance level shall be depend on the importance of structure.

【commentary】

Performance levels set one or more levels of performance that a steel or composite structure must satisfy. Performance levels may be set for any of the six performance requirements: safety, serviceability, restorability, durability, social and environmental compatibility, and workability. As an example, Table C2.3.1 shows the performance levels relating to vehicle operating performance as described in section 7.2.1 of the Design volume.

Performance levels depend on the importance of the steel or composite structure. Meanwhile, since partial safety factor design format is the basic method of performance verification in these specifications, it is possible to change the structure factor instead of establishing various performance levels. The structure factor also takes into account other specific conditions: social influence if the structure reaches the limit state, importance of the structure with regard to disaster prevention measures, economic factors relating to reconstruction or repair costs, etc.

Table C2.3.1 Example of performance levels relating to vehicle operating performance

Level	Action and weather conditions	Performance item	Details
Level 1	<ul style="list-style-type: none"> • Live-load acting during design working life • Weather condition 1 (low wind velocity and little rainfall) 	Vehicle operating performance under normal conditions	Safety shall be secured and users should suffer no unpleasant effects.
Level 2	<ul style="list-style-type: none"> • Weather condition 2 (wind velocity and rainfall are greater than an a priori determined level) 	Vehicle operating performance under abnormal conditions	Safety shall be secured although normal vehicle operating performance may be degraded to some degree.

References in Chapter 2

Japanese Society of Steel Construction (2001) : Performance design guidelines for Civil Engineering Steel Structures, JSSC Technical Report No. 49.

Ministry of Land, Infrastructure, Transport and Tourism (2002) : Design Basis for Civil and Architectural Engineering Structures .

Japan Society of Civil Engineers (2003) : Towards Establishment of Performance-based Design System for Steel Structures .

Volume II Structural Planning

Standard Specifications for Steel and Composite Structures 【 Structural Planning 】

Contents

Chapter 1 General	1
1.1 Scope of Structural Planning	1
1.2 Considerations in Structural Planning	1
1.3 Supplementary considerations in structural planning	2
Chapter 2 Constraints and Prerequisite Conditions in Structural Planning	3
2.1 Constraints by Laws and Regulations of Structure	3
2.2 Prerequisite Conditions for Performance Verification	3
Chapter 3 Economic Efficiency	5
3.1 General	5
3.2 Method of Consideration	5
Chapter 4 Safety	6
4.1 General	6
4.2 Method of Consideration	6
Chapter 5 Serviceability	8
5.1 General	8
5.2 Method of Consideration	8
Chapter 6 Durability	10
6.1 General	10
6.2 Consideration of Fatigue Resistance	10
6.3 Consideration of Corrosion Resistance	11
6.4 Consideration of Resistance to Material Deterioration	11
Chapter 7 Social and Environmental Compatibility	13
7.1 General	13
7.2 Consideration of Landscape	13
7.3 Consideration of Noise and Vibration	14
7.4 Consideration for Reduction of Environmental Impact	14
Chapter 8 Maintenance	15
8.1 General	15
8.2 Consideration of Future Potential Problems	15
8.3 Consideration of Maintenance Facilities	16
Chapter 9 Consideration for Influence of Earthquakes	17
9.1 General	17
9.2 Selection of Type of Structure with High Seismic Performance	17
9.3 Consideration for Safety during Earthquakes, and Restorability	17
Chapter 10 Constructability	19
10.1 General	19
10.2 Consideration for Constructability during Shop Fabrication	19
10.3 Consideration for Constructability during Erection	19

Chapter 1 General

1.1 Scope of Structural Planning

A structure shall comply with its intended purpose, satisfy conditions in applicable laws and regulations, and be economical. It shall also have adequate safety, serviceability, durability, safety during earthquakes, serviceability and restorability after earthquakes, social and environmental compatibility and maintainability. For those requirements, structural planning should be performed to select an appropriate form and type of structure, and to decide an outline of the structure such as major dimensions.

【Commetary】

The structural planning phase of building a structure is the work of determining the form and structural, the major dimensions, etc.; that is, the outline of the structure is defined through the structural planning process. This work is, in general, carried out after the basic investigation. It is important work that affects the overall project cost and construction period, as well as maintainability after the structure opens for use. Careful study is required because the structural planning process is almost the sole determinant of construction cost and construction period.

It is important through the structural planning process to select the form and type of structure best able to meet the full range of requirements and required performances. That is, it is essential to select the ideal form and type of structure that, while fulfilling its intended purpose and satisfying the conditions set by applicable laws and regulations, is economically efficient. The selected form and type of structure must also exhibit adequate safety, serviceability, durability, safety during earthquakes, serviceability and restorability after earthquakes, social and environmental compatibility, and maintainability against external action throughout its service life.

1.2 Considerations in Structural Planning

In structural planning, a structure should be conformed to its intended purpose and be fitted to conditions in applicable laws and regulations. Considerations for economic efficiency, safety, serviceability, durability, social and environmental compatibility, maintenance, influence of earthquakes, and constructability of a structure should also be considered in structural planning. During structural planning, adequate comparisons and considerations for each form and type of structure should be performed.

【Commentary】

(1) Considerations in Structural Planning

The structural planning process ensures that a structure fulfills its intended purpose and conforms to applicable laws and regulations and is economically efficient. At the same time, safety, serviceability, durability, social and environmental compatibility, maintenance after construction, earthquake influence, and workability, etc. should also be considered in structural planning. In addition, as part of earthquake influence, restorability should be considered.

(2) Comparison of structural forms and types

In order to select the ideal form and type of structure, it is necessary to compare alternative structural forms and types with respect to the considerations prescribed in (1) above. For example, in the structural planning of a bridge, it is necessary to compare and consider forms and types including steel bridges, RC bridges, PC bridges, etc., taking into account their economic efficiency, social and environmental compatibility, workability as well as the required span and existing ground conditions. Because construction cost is substantially determined through this selection process in many cases, it is essential to give it sufficient attention. In considering economic efficiency, it is desirable to consider the full life cycle cost, including the cost of maintenance, as well as the initial construction cost.

1.3 Supplementary Considerations in Structural Planning

In addition to the considerations prescribed in 1.2, construction period and ground condition should be taken into account.

【Commentary】

Further to the considerations prescribed in 1.2 above, construction period and ground conditions should be taken into account through the process of structural planning.

(1) Construction Period

It is necessary to select a form and type of substructure in consideration of its consequent effect on construction period and economic efficiency (construction cost). For example, in the case of a bridge crossing a river, the selected form and type of substructure and superstructure may require construction to take place only in the dry season while the selected form and type of a bridge over a railway or road may restrict the time available for construction.

(2) Ground Conditions

There are cases where detailed ground conditions, etc. are not examined at the structural planning stage. However, once the form and type of structure is selected, there are a great many cases when they cannot be changed afterwards. Consequently, it is necessary that structural planning be based on the most accurate possible information about special ground conditions, such as inclined ground, weak ground, etc.

References in Chapter 1

- Japan Society of Civil Engineers (1989) : Civil Engineering Handbook, Vol. 4
- Japan Railway Construction Public Corporation (1998) : Guidance for Structural Planning (Draft)
- Japanese Society of Steel Construction (2001) : Performance design guidelines for Civil Engineering Steel Structures, JSSC Technical Report No. 49
- Japan Society of Civil Engineers, Steel Structure Committee (2003) : Development of Performance-Based Design System for Steel Structures
- East Nippon Expressway Company Limited, Central Nippon Expressway Company Limited, West Nippon Expressway Company Limited (2006) : Design Guide Vol. 2

Chapter 2 Constraints and Prerequisites Conditions in Structural Planning

2.1 Constraints by Laws and Regulations of Structure

For construction of a structure, applicable laws and regulations should be well considered. If there is some restriction by other structures, the structure should satisfy applicable laws and regulations, and adequate consultation with related organizations should be held.

【Commentary】

In the planning of a structure, laws and regulations may apply to the usage and/or function of the structure, resource usage and/or waste disposal, environmental preservation, work safety, etc.

Further, in verifying each performance requirement, there are certain prerequisite conditions such as actions to be supported, design working life, etc. In this specification, these are dealt with as constraints and prerequisites to be considered, not as individual performance requirements. In this clause, the minimum requirements to be satisfied are determined in consideration of the constraints imposed by laws and regulations.

The form and type of a structure and its size may be restricted by laws and regulations related to other structures where other structures are intersecting or adjoining.

Further, in conferring with related organizations, various requirements may be lodged by with regard to the form and type of structure and its span, etc.

Accordingly, it is necessary to confer with related organizations about the plan as well as to carry out structural planning in full consideration of the content and spirit of related laws, ministerial ordinances, etc.

2.2 Prerequisite Conditions for Performance Verification

For construction of a structure, prerequisite conditions such as actions to be supported and design working life should be considered at the stage of structural planning.

【Commentary】

It is necessary that a new structure satisfy the required performance given the assumed actions that will occur over the design working life. Therefore, it is necessary to verify each performance requirement in the round from the structural planning stage; that is, the range of actions and the design working life must be taken into account at the structural planning stage. In this specification, these performance requirements are treated as prerequisites to be considered in the construction of the structure.

The type and characteristic values of actions to be taken into consideration are set as standard for each type of structure and these can, in general, be used. In verifying the structural plan for a new structure, it is necessary to determine adequately these characteristic values of actions and to assume a worst-case combination of these actions on the structure in general.

Each structural type has a standard design working life and, in general, this can be used. It is preferable to consider durability from the structural planning stage, including the method of mainte-

nance during the structure's working life, and it is important to clarify the design working life of the new structure.

References in Chapter 2

Tokyo Metropolitan Government (1987) : Design Guide to Bridges .

Japan Railway Construction Public Corporation (1998) : Guidance for Structural Planning (Draft) .

Editorial Supervisor: Railway Technical Research Institute (2000) : Design Standards for Railway Structures and Commentary (Steel and Composite Structures) .

Japan Road Association (2002) : Specifications for Road Bridges and Commentary, I: Common Reference Volume .

Japan Society of Civil Engineers, Steel Structure Committee (2003) : Development of Performance-Based Design System for Steel Structures .

East Nippon Expressway Company Limited, Central Nippon Expressway Company Limited, West Nippon Expressway Company Limited (2006) : Design Guide Vol. 2

Chapter 3 Economic Efficiency

3.1 General

Economic efficiency should be taken into account at the stage of selecting form of structure, selecting type of structure and calculating major dimensions.

【Commentary】

In many cases, cost can be significantly reduced by selecting an appropriate form and type of structure at the structural planning stage. Therefore, it is extremely important during structural planning to select a form and type of structure that offers excellent economic efficiency. In this consideration, it is necessary to compare structural forms and types including not only steel and composite structures but also concrete structures and hybrid structures. Although economic efficiency is an important consideration in structural planning and is prescribed in this chapter, it is also included in the Design Part as a performance item (economical rationality), where it is considered part of the social and environmental compatibility of a structure.

3.2 Method of Consideration

Economic efficiency should be considered in terms of initial cost and life cycle cost.

【Commentary】

In considering the economic efficiency of a structure, it is necessary to look at life cycle cost, which includes the cost of maintenance, the cost of replacement cost, etc., as well as the initial cost. Further, it should be optimized from the view point of wide-ranging asset management, so that not only is each individual structure optimized, but also, for example, the whole railway route or network.

Structures must be maintained regularly. Then they have to be replaced when they are no longer able to meet the required performance. The cost of maintenance, replacement, etc. arising after construction may greatly exceed the initial construction cost. Therefore, in structural planning, it is important to evaluate a structure not only in terms of initial construction cost but also according to future maintenance and replacement costs as estimated during the structural planning process. However, since the structure has not been given detailed consideration at this stage, the exact dimensions, etc. of each member of the structure may not be fixed; in this case, it is necessary to use information of construction cost and maintenance cost, etc. based on past experience with similar structures.

References in Chapter 3

- Kazuhiro NISHIKAWA (1997) : Proposal for minimum maintenance bridge that minimizes the life cycle cost of a road bridge, Bridge and Foundation, Vol. 31, No.8 .
- Japan Railway Construction Public Corporation (1998) : Guidance for Structural Planning (Draft) .
- Masaki YOKOYAMA, Nobuo SAITO, Osamu OMURA, Takayuki TSUZUKUIISHI (1999) : Study on the life cycle cost of road bridge and its circumstances in the United States, Material collections of 1st symposium concerning maintenance of steel structures .
- Japan Society of Civil Engineers, Steel Structure Committee (2003) : Development of Performance-Based Design System for Steel Structures .

Chapter 4 Safety

4.1 General

Safety should be considered at the stage of selecting form and type of structure and calculating major dimensions.

【Commentary】

For any structure, it is necessary to secure safety at all times against various external actions over the working life. Structural sections are often determined by satisfying safety requirements. A further comparative consideration of economic efficiency, etc. is necessary to select the best structural form and type, which is the purpose of structural planning, and it is necessary, in order to compare economic efficiency, to decide on the main major dimensions of the structure and calculate the quantities of work and the construction cost. From this perspective, an examination of safety is necessary at the structural planning stage.

4.2 Method of Consideration

Safety should be considered in accordance with the Design Part, Chapter 6 "Required performances and verification for safety".

【Commentary】

In the consideration of safety during the structural planning process, the required safety performance must be met in reference to the Design Part, Chapter 6 "Required performances and verification of safety".

The Design Part includes sections on "Structural safety" and "Public safety". The main consideration here is structural safety. Structural safety should usually be verified against dynamic phenomena in consideration of strength, rigidity, deformation, stability, etc. At the structural planning stage, not all items taken into account at the detailed design need be considered, but only those that are necessary. Depending on the form and type of the structure, it may be difficult to consider all safety verifications beforehand. In such cases, it is acceptable to understand the problems by doing a rough calculation, reflect the results in the structural plan, and decide on verification items and values. It is not the aim to optimize the section, shape and dimensions at the structural planning stage.

In general, the verification of safety at the structural planning stage should be carried out as follows.

- (1) In cases where an outline consideration is acceptable
 - ① Where there is experience with the form and type of structure and its scale, it is possible to understand the major dimensions, materials, etc. without calculating actual sectional forces (stresses) and cross-sectional dimensions.
 - ② Where a choice is made from among multiple alternative structural forms and types, the stress intensity of main members can be considered using a simple model (lattice analysis, infinitesimal deformation analysis, etc.) in general.
 - ③ For a structure where the earthquake influence is predominant in the above-mentioned structural analysis, it is necessary to consider earthquake safety using a simple static verification

according to "Chapter 9 Earthquake Influence".

(2) In cases where a comparatively detailed consideration is required

- ① Where there is no experience with the form and type of structure or its scale, or where the various dimensions of the structural members are close to the applicable limit of the structural form and type, it is necessary to consider detailed design.
- ② Where a choice is made from among several alternatives, it is necessary to calculate the sectional forces (stresses) using an adequate model and to consider safety in the section where the whole quantities of the structure (the total steel weights, etc.) can be calculated.
- ③ For a structure where the earthquake influence is predominant, it is necessary to consider the earthquake safety using a simple static verification according to "Chapter 9 Earthquake Influence", including dynamic analysis if necessary.

References in Chapter 4

Japan Railway Construction Public Corporation (1998) : Guidance for Structural Planning (Draft) .

Japan Society of Civil Engineers, Steel Structure Committee (2003) : Development of Performance-Based Design System for Steel Structures .

East Nippon Expressway Company Limited, Central Nippon Expressway Company Limited, West Nippon Expressway Company Limited (2006) : Design Guide Vol. 2 .

Chapter 5 Serviceability

5.1 General

Serviceability should be taken into account at the stage of selecting form and type of structure and calculating major dimensions.

【Commentary】

The meaning of serviceability is that structure's functions are secured, that maintenance does not require excessive cost and labor, that no feelings of anxiety are induced in users, and that no function-disrupting phenomena occur. The choice of structural form and type may be influenced by serviceability considerations, while major dimensions may be determined on the basis of fulfilling serviceability requirements. Serviceability should therefore be considered from the structural planning stage.

5.2 Method of Consideration

Serviceability should be considered in accordance with the Design Part, Chapter 7 "Required performances and verification for serviceability".

【Commentary】

It is necessary to consider serviceability during the structural planning stage in order to avoid the need for later corrections, such as changing the structure type, at the design stage. The required serviceability is to be obtained in accordance with the Design Part, Chapter 7 "Required performances and verification of serviceability".

Taking a road bridge as an example of a steel or composite structure, suitable performance items to be considered as relevant to serviceability are performance under moving vehicle loading and pedestrian loading, depending on the actual application of the bridge. That is to say, at the structural planning stage, it is necessary to consider certain questions directly linked to the structure form and dimensions of the structure. These include such points as the location, intended purpose, and level of importance of the structure, the planning of a road alignment that meets performance requirements, and the examination, depending on the type of bridge, of deformations under moving vehicle loading and vibrations under pedestrian loading.

For structures other than bridges, there may be different definitions of serviceability. For example, in the case of port and harbor structures, serviceability may be defined in terms of performance items directly connected to the function of the structures. In the case of earthquake-reinforced structures involved in the transportation of dangerous materials, it is necessary that the facility is still available for normal operations after earthquake motion of level 2. Further, in the case of port and harbor structures, there are many types of structure that require water-tightness, such as floating moorings and submerged tunnels. In this way, the definition of serviceability in port and harbor structures directly indicates the performance that the facility is not disabled in use and structural response of the facility to envisaged action is required to control the damage in order that the structure is easily restored to the original performance by small restoration work.

References in Chapter 5

Japan Road Association (2002) : Specifications for Road Bridges and Commentary .

Japan Society of Civil Engineers, Steel Structure Committee (2003) : Development of Performance-Based Design System for Steel Structures .

Japan Road Association (2004) : Practical guide and implementation of Road Construction Ordinance .

Japan Port and Harbor Association (1999) : Technological Standard for Harbor Facilities and Commentary .

Chapter 6 Durability

6.1 General

Durability should be taken into account at the stage of selecting form and type of structure and calculating major dimensions.

【Commentary】

The performance of structure gradually deteriorates due to the action of loading and the environment. Therefore, to fulfill the durability requirement, the deterioration of performance level should be held within certain limits such that adequate performance is maintained during the design working life of the structure. The durability should be considered from the structure planning stage. Durability is defined as the resistance of a structure or its members to performance deterioration under the action of loading and the environment. It is extremely important that the necessary level of performance is maintained throughout the design working life of the structure.

In considering the durability of steel and composite structures, it is generally adequate to review fatigue resistance (that is, resistance to fatigue phenomena as caused by loading), corrosion resistance (that is, resistance to corrosion of steel materials under environmental action), and material deterioration resistance (that is, resistance to material deterioration phenomena that affect concrete materials, etc.). That is to say, it is necessary to suppress these factors within defined limits; further, it is recommended that these factors relating to durability are checked from the structural planning stage onward.

6.2 Consideration of Fatigue Resistance

In principle, a type of structure that is concerned for fatigue resistance should be selected in the consideration for durability.

【Commentary】

Fatigue resistance is usually checked by calculating the response to loading action. Then it is confirmed that the response is below a certain limit value, such as the allowable stress range for fatigue, for each respective member of a structure.

However, one of the worst scenarios with respect to fatigue damage is when fatigue cracks initiated after the structure enters service lead to an incident because inspections or countermeasures are impossible to implement. To avoid this kind of situation, it is recommended that a design in which stress concentrations are very unlikely or one in which it is easy to identify fatigue cracking be considered from the structural planning stage. Further, since some structural members, such as the hangers of Langer bridges and the cables of cable-stayed bridges, are subjected to wind-induced vibration, it is advisable to include relevant consideration of this from the structural planning stage.

In the case of bridge designs in which fatigue damage tends to occur, it is necessary to consider avoiding the use of joints with lower fatigue strength at the structural planning stage, since the response to loading action tends to be greater in the case of bridges with closely-spaced supports and bridges subjected to frequent over-sized vehicle loading.

It is also recommended that the fatigue resistance of not only steel-plate decks but also concrete floor slabs such as those fabricated as RC slabs, PC slabs be considered, since these are exposed to severe fatigue conditions because they directly support repeated wheel loading.

6.3 Consideration of Corrosion Resistance

In principle, specific corrosion protections that have adequate corrosion resistance should be selected in the consideration for durability.

【Commentary】

The corrosion resistance of steel materials represents their performance with respect to inhibiting corrosion caused by environmental action, etc. to below a defined level during the design working life. Anticorrosion design aimed at preserving the required performance, such as by developing specifications that adequately counter corrosion, should be considered from the structural planning stage. Also, concurrently with this assurance of corrosion resistance, anticorrosion specifications matched to the environmental action are required from the point of view of life-cycle cost.

There are various methods of inhibiting the corrosion of steel materials, such as by painting, application of weathering steel, hot-dip galvanizing, stainless steel or titanium covering, aluminum alloy thermal spraying, and electrolytic protection. It is recommended that the most suitable method be selected after a thorough comparative investigation of those methods applicable to the structure's in-service environment.

The factors that lead to the initiation and development of corrosion vary depending on the environment in the structure's location. For example, if a steel structure in a coastal location subject to airborne salt remains underwater for long periods due to poor drainage, corrosion accelerates. It is particularly important in the case of a complex structure consisting of many structural members to understand the increased exposure time to water resulting from rain and dew condensation as well as the significant effect that can result from deposits of sand and anti-freezing agents.

In less severe corrosive environments, unpainted steel structures that use weathering steel generally remain in good condition because a dense corroded layer forms. However, steel structures located on the coast and steel bridges subjected to the spraying of anti-freeze agents (sodium chloride, calcium chloride) do not form this kind of dense corrosion layer in some places and then extraordinary forms of corrosion, such as the imbricate form, are initiated and developed. In this kind of environment, a higher level of anticorrosive specifications must be implemented.

In the case of concrete structural members such as floor decks, it is necessary to hold the neutralization thickness of the concrete cover and the concentration of chloride ions, etc. within defined limits throughout the design life so as to ensure the corrosion resistance of the reinforcing steel.

6.4 Consideration of Resistance to Material Deterioration

In principle, materials that have adequate resistance against material deterioration should be selected in the consideration for durability.

【Commentary】

Concrete's resistance to material deterioration of concrete represents its performance with respect to limiting aging deterioration resulting from environmental action, etc. to a defined level during the design working life of the structure. The anticipated material deteriorations of concrete are neu-

tralization, freezing and thawing, chemical corrosion, and the alkali-aggregate reaction, etc. It is recommended that, at the structural planning stage, materials with excellent resistance to material deterioration are selected in consideration of environmental action. Also, it is important to pay attention to the initiation and development of corrosion of reinforcing steel within the concrete, which may result from neutralization or salt damage.

In addition, it is not necessary to consider the aging deterioration of steel materials for typical civil engineering structures. However, in the case of tanks, water gates and water pressure steel pipes, for example, the metallurgic aging deterioration may occur as a result of the graphitization or the hydrogen embrittlement. Therefore, in this kind of structure, it is necessary to select materials with excellent resistance to material deterioration from the structural planning stage.

References in Chapter 6

- Editorial Supervisor: Railway Technical Research Institute (2000) : Design Standards for Railway Structures and Commentary (Steel and Composite Structures) .
- Japan Society of Civil Engineers, Concrete Structure Committee (2002a) : Standard Specifications for Concrete Structures (Structural Performance Check Volume) .
- Japan Society of Civil Engineers, Joint Sub-Committee of Steel Structures and Concrete Composite Structures (2002b) : Guidelines for Performance Check of Hybrid Structures .
- Japan Road Association (2002) : Fatigue Design Guideline for Steel Road Bridges .
- Chitoshi Miki, Atsushi Ichikawa (2004) : Modern Bridge Engineering - Leading-edge Technology in Paint-less Steel and Bridges, Mathematical Engineering Company .

Chapter 7 Social and Environmental Compatibility

7.1 General

At the stage of selecting form and type of structure, social and environmental compatibility should be taken into account in principle.

【Commentary】

Since civil engineering structures play an important role in their surrounding environments or urban landscapes as a component of the social capital, it is necessary to consider these landscapes in structural planning. Further, structural forms or types that cause discomfort or stress among users and residents should be avoided because civil engineering structures remain in use for a considerably long period after entering service. Therefore, the structural form and type should be selected in consideration of its environmental impact, including such effects as noise, vibration, sunshine masking, and air pollution as well as its harmony with the local ecology. Furthermore, it is desirable to select materials and structural forms and types taking into consideration their adaptability to recycling from the viewpoints of resource management and environmental damage reduction.

Social and environmental compatibility is a function of a structure that contributes to a sound social, economic, and cultural community and minimizes negative impacts on the social and natural environment. Accordingly, taking into account of social and environmental compatibility in principle, necessitates study of landscape, noise, vibration, and other environmental factors that must be considered at the structural planning stage.

7.2 Consideration of Landscape

Landscape should be concerned in the consideration for social and environmental compatibility.

【Commentary】

Consideration of the landscape is necessary because civil engineering structures are likely exposed to the public eye. In general, there are various ways of understanding landscape issues, but the point here is how to coordinate a structure with the surrounding environments or urban environment and how to create a contrast with it. It is an important aspect of gaining favorable acceptance from users and nearby residents. It is difficult to evaluate landscape using a quantitative approach because landscape is a concept strongly depending on subjective and sensory judgment. However, it is generally necessary to take into consideration the following in selecting a structural form and type:

- ① The structural form and type should exhibit a balance of structural forces.
- ② The structural form and type should be able to cope with the demands on it.
- ③ The unity of structural form and type should be considered as much as possible.
- ④ Methods of linking parts of the structure should be carefully considered so as not to spoil the look of the structure.

7.3 Consideration of Noise and Vibration

Noise and vibration should be concerned in the consideration for social and environmental compatibility.

【Commentary】

- (1) Noise: For structural planning, noise abatement measures should be taken into account if necessary. In this case, any environment standard applicable to the location of the structure is referred to.
- (2) Vibration: There are an increasing number of cases in which structure-induced vibrations are causing environmental problems. Often, these cases arise where a bridge section is located on weak ground or on excavated soil.
- (3) Sunshine masking: For a structure in an urban area, due consideration should be given to the masking effect it will have on sunshine.
- (4) Others: It is also necessary to adequately consider the possible influence of noise, vibration, and water contamination during the construction period.

7.4 Consideration for Reduction of Environmental Impact

Reduction of environmental impact by effective utilization of resources should be concerned in the consideration for social and environmental compatibility.

【Commentary】

It is desirable to consider reducing environmental impact through the effective use of resources at the structural planning stage. The effective use of resources depends on controlling waste generation (reduce), reusing construction components (reuse), and reusing construction materials as raw materials (recycle). Since it is relatively easy to increase the working life of a steel structure through partial repair or reinforcement, it has been pointed out that it is relatively easy to reuse the main parts or components, and furthermore to reuse the material (steel). This implies that steel structures offer excellent characteristics with respect to "reduce," "reuse," and "recycle". In particular, steel has excellent recycling properties. In practice, when a bridge is replaced, the steel can be reused after processing at a steelworks after scrapping. As for "reuse," temporary structures such as marine staging are often made of leased material which is reused.

References in Chapter 7

- Railway Construction Public Corporation, Study Group on Landscape Design (1977) : Handbook of landscape design for railway structures (draft) .
- Railway Construction Public Corporation (1998) : Handbook for Structural Planning (draft) .
- Japan Road Association (2002) : Specifications for Highway Bridges and Commentary, I Common Specifications Volume .
- East Nippon Expressway Company Limited, Central Nippon Expressway Company Limited, and West Nippon Expressway Company Limited (2006) : Design Guide Vol.2 .

Chapter 8 Maintenance

8.1 General

At the stage of selecting form and type of structure, maintenance should be taken into account to ensure initially intended performance after the start of service.

【Commentary】

Maintenance is essential for all structures once they enter service. Since the physical life of a structure largely depends on the maintenance work carried out, its physical life can be extended to two or three times the design working life. In this regard, it is necessary to consider the ease with which steady maintenance can be carried out at the structural planning stage in order to satisfy the structure's performance requirements throughout its design working life.

8.2 Consideration for Future Potential Problems

Future potential problems with maintenance of structure should be considered at the stage of structural planning.

【Commentary】

Potential future issues related to structure maintenance should be adequately reflected in the structural planning, with reference to the following examples which have arisen in the past.

(1) Settlement, tilting, and displacement of the structure

If, for example, a structure is planned without sufficient consideration of ground deformation where the land is reclaimed or consists of weak soil, unexpected lateral movement/differential settlement of the stratum may take place, as has been experienced a number of times. Countermeasure against such movement are very expensive. Therefore, during structural planning, sufficient investigations should be carried out to verify if any structural problems had have been experienced by other structures under similar conditions.

(2) Vibration, noise, and abnormal deflection

Cases have been noted where, since a steel structure generally consists of thin components, unexpected vibration, noise, or abnormal deflection has resulted. This is particularly likely if the structure consists of thin plate elements or a girder structure with low rigidity.

(3) Damage due to lack of recognition of the environment at the structure's location

Many examples of failure to properly understand the environment a structure is exposed to have led to difficulty in maintenance work and a significantly reduced service life as a result of failure to select suitable materials/structures. Therefore, it is important to select the most suitable materials and structural type based on a careful investigation of the environment at the location of the structure when it enters service and in the future.

8.3 Consideration of Maintenance Facilities

Maintenance facilities for a structure should be considered at the stage of structural planning.

【Commentary】

While a structure needs maintenance work during its service period, the structural type or form sometimes presents difficulties with respect to making inspections/examinations for maintenance. In selecting a structural type and form, it is necessary to consider how maintenance working space will be secured and what maintenance facilities are required for inspection and repainting, together with consideration of the ease of maintenance work, at the structural planning stage. Further, if partial repair or replacement of the structure is anticipated in the future, it is better to consider what facilities are required to allow such work.

References in Chapter 8

Nobuyuki Narita (1998) : Future of Steel Bridges, Gihodo publishing co. .

Tokyo Metropolitan Government (2002) : Inspection Manual of Bridges .

Japan Society of Civil Engineers (2003) : Towards Establishment of Performance-based Design System for Steel Structures .

Chapter 9 Consideration for Influence of Earthquakes

9.1 General

If the influence of earthquakes is dominant in a structure, influence of earthquakes should be considered at the stage of selecting form and type of structure and calculating major dimensions.

【Commentary】

A structure should possess sufficient seismic resistance (seismic safety and post-earthquake serviceability and restorability) to earthquakes. The cross-sectional dimensions of structural members are likely to be determined from the viewpoint of conformity with this performance requirement. For this reason, it is necessary to review earthquake scenarios from the structural planning stage. In particular, where the response of a structure by earthquake motion is large, a structural form and type with good seismic resistance is to be selected and conformity with the required seismic performance is to be checked.

9.2 Selection of Type of Structure with High Seismic Performance

Topography, geology, ground condition and locational condition should be considered at the stage of selecting form and type of structure. Then the type of structure that has adequate safety during earthquakes, serviceability and restorability after earthquakes should be selected.

【Commentary】

In choosing the form and type of a structure where the response will be largely dominated by earthquake motion, it is important to select a structure that excels in seismic resistance and offers a high degree of seismic safety and post-earthquake serviceability and restorability, taking into consideration topographical, geological, ground, and locational conditions. Here, it is important to select not only individual structure members with excellent seismic resistance but also a structure that has excellent seismic resistance as a whole system.

9.3 Consideration for Safety during Earthquakes, and Restorability

- (1) Prospective earthquake motion and importance of structure should be determined in the consideration for safety during earthquakes, serviceability and restorability after earthquakes.
- (2) Appropriate seismic performance should be determined in accordance with the prospective earthquake motion and the importance of structure, which are determined in (1).
- (3) A structure should satisfy the seismic performance, which are required in (2), in the consideration for safety during earthquakes, serviceability and restorability after earthquakes.

【Commentary】

- (1) In reviewing the influence of earthquakes on a structure, it is necessary to define the anticipated

earthquake motions and the importance of the structure.

The seismic intensity acting on a structure as a result of an earthquake depends on the characteristics of seismic event, seismic wave transmission characteristics, and ground conditions. Further, the response of a structure to an earthquake can vary depending not only on the amplitude of the input earthquake motion but also on its periodic component. Accordingly, it is recommended, in reviewing the influence of earthquakes on a structure, to define the anticipated earthquake motion as a result of a thorough understanding of these characteristics. However, it is difficult to develop definitions individually for every form and type of structure. Therefore, it is usually acceptable to define the anticipated earthquake motion according to the design standards of the intended structure.

Further, it is necessary to define the importance of the structure appropriately according to the design standards of the intended structure in consideration of its social role.

- (2) and (3) It is necessary to define the structure's seismic resistance in accordance with the anticipated earthquake motion and the importance of structure as defined in (1) above. Then, in reviewing the seismic resistance of the structure, this defined seismic resistance must be achieved.

Meanwhile, in reviewing the influence of earthquakes at the structural planning stage, it is unnecessary to use a more complex design method than called for. A simple method is acceptable as long as the necessary data can be obtained. For example, in a case where the structural form and type or data needed to determine the major dimensions can be obtained from past examples and where there is no problem with estimating the response characteristics of the planned structure to the earthquake, it is acceptable to carry out this review of the influence of earthquakes through a static analysis instead of a dynamic analysis.

References in Chapter 9

- Railway Technical Research Institute (1999) : Design Standards for Railway Structures and Commentary, Earthquake-resistant Design .
- Japan Society of Civil Engineers (2001) : Guideline of Earthquake-resistant Design for Civil Structures (Draft), Handbook for Preparation of Earthquake-resistance Design Standards .
- Japan Road Association (2002) : Specifications for Highway Bridges and Commentary, V Earthquake-resistant Design Volume .
- Tsutomu Usami (2006) : Guideline for Earthquake-resistance and Vibration Control in Steel Bridges, Editorial Supervisor: Japanese Society of Steel Construction, Gihodo .

Chapter 10 Constructability

10.1 General

At the stage of selecting form and type of structure, constructability should be taken into account.

【Commentary】

Since various restrictions related to factory fabrication, transportation, and erection steel may affect the design of composite structures, it may be that a certain structural form and type is rendered unworkable. For example, in bridges that cross rivers, roads, or railroads, it is not unusual for the type of structure to be constrained by the selected erection method. Further, if the working space is constrained, such as where ground conditions are very difficult, the urban location restricts space, or the environment has to be preserved, choosing the appropriate erection method may have a large influence on economic efficiency and margin of safety.

Thus, it is necessary at the structural planning stage to select the type of structure taking into consideration not only the completed structural system but also its workability. Here, it is acceptable to review the workability of shop fabrication, transportation, and erection methods as well as the erection conditions of steel structures.

10.2 Consideration for Constructability during Shop Fabrication

In the consideration for constructability, constructability during shop fabrication should be considered in principle.

【Commentary】

Steel and composite structures should be of easily fabricated structure to the degree possible. For example, it is considered that fabrication is simplified by the adoption of structural members of simple design and by reducing the number of structural members as a consequence of simplifying the structure. Similarly, the number of man-hours required is reduced by the adoption of available shaped steel (I-beams, H-section steel, steel pipes, etc.).

10.3 Consideration for Constructability during Erection

In the consideration for constructability, constructability during erection should be c in principle.

【Commentary】

The method used to erect a structure (e.g. bent erection, erection by cable, etc. in the case of a bridge) is generally determined in consideration of topographical conditions at the erection site (narrow intermontane valley, river zone, marine straits, railroad grade crossing, road, or urban zone, etc.), with constraints applied according to fieldwork (consultation with local residents, work during

the dry season in a river zone, erection in an environmental preservation area, erection in limited space in an urban zone, and erection process in the field, etc.) and the limitations of erection equipment, etc.

References in Chapter 10

Construction Industry Research Company (1990) : Handbook for Design and Construction of Bridges .

Japan Society of Civil Engineers, Steel Structure Committee (2003) : Development of Performance-Based Design System for Steel Structures .

Volume III Design

Standard Specifications for Steel and Composite Structures 【 Design 】

Contents

Chapter 1 General Provisions	1
1.1 Scope	1
1.2 Terms and Definitions	1
1.2.1 Commonly used terms	1
1.2.2 Terms used in this Design volume	5
1.3 Notation	5
1.4 Basis of Design	7
1.4.1 Purpose of design	7
1.4.2 Verification of performance	8
1.4.3 Verification method	15
1.4.4 Partial factors	17
1.4.5 Modification factors	17
1.5 Structural Factor	18
Chapter 2 Actions	19
2.1 General	19
2.2 Kinds of Actions	20
2.3 Combinations of Actions	20
2.4 Action Values	22
2.4.1 General	22
2.4.2 Dead load	23
2.4.3 Earth pressure	24
2.4.4 Prestressing force	24
2.4.5 Live load	25
2.4.6 Impact load	25
2.4.7 Flowing water pressure	26
2.4.8 Hydrostatic pressure	26
2.4.9 Buoyancy or uplift	27
2.4.10 Wind load	27
2.4.11 Snow load	28
2.4.12 Braking force and acceleration force	29
2.4.13 Centrifugal force	29
2.4.14 Longitudinal load imposed by long welded rail	30
2.4.15 Lateral train load and transverse wheel thrust	30
2.4.16 Wave pressure	30
2.4.17 Erection-related force	30
2.4.18 Collision force	31
2.4.19 Concrete shrinkage	31
2.4.20 Effect of concrete creep	32
2.4.21 Effect of temperature changes	33
2.4.22 Effects of displacement of supports and differential settlement	34
2.4.23 Effect of earthquake	35
2.4.24 Effect of airborne salinity	37
2.4.25 Effect of exhaust gases	37

2.4.26	Effect of carbon dioxide concentration	37
2.4.27	Effect of acid concentration	38
2.4.28	Effect of drying and wetting	38
2.4.29	Effect of sunshine	38
2.4.30	Effect of freezing	39
2.4.31	Effect of fire	39
2.5	Action Factors	39
Chapter 3	Materials	45
3.1	General	45
3.1.1	Fundamentals of material physical properties	45
3.1.2	Required properties of materials	45
3.2	Structural Steel	46
3.2.1	Required steel properties	46
3.2.2	Selection of steel type	46
3.3	Concrete	50
3.4	Value of Material Properties for Design	50
3.4.1	General	50
3.4.2	Structural steel	51
3.4.3	Concrete	54
3.5	Partial Factors for Materials	54
Chapter 4	Structural Analysis	57
4.1	General	57
4.2	Structural Analysis Factor	62
Chapter 5	Structural Member Resistance	64
5.1	General	64
5.2	Partial Factor for Uncertainty in Resistance	64
5.3	Steel Member Resistance	65
5.3.1	Tensile resistance	65
5.3.2	Compressive resistance	66
5.3.3	Bending resistance	68
5.3.4	Shear resistance of web	74
5.3.5	Local buckling resistance	76
5.4	Resistance of Steel Pipes	83
5.5	Resistance of Cables	85
Chapter 6	Demand for Safety and Verification	87
6.1	General	87
6.2	Performance Requirement for Safety	87
6.2.1	Structural Safety	87
6.2.2	Public Safety	88
6.3	Verification of Structural Safety	88
6.3.1	Verification of load-carrying capacity	88
6.3.2	Verification of Displacement/Deformation Capacity	103
6.3.3	Verification of Stability	103
6.4	Verification of Structural Safety by Nonlinear Structural Analysis	105
6.5	Verification of Structural Safety through Experiment	106
Chapter 7	Required Serviceability Performance and Verification	107
7.1	General	107
7.2	Required Performance for Serviceability	107

7.2.1	Vehicle operating performance	107
7.2.2	Train operating performance	108
7.2.3	Pedestrian comfort	110
7.2.4	Other Considerations for Users	111
7.3	Verification of Serviceability	111
7.3.1	Verification of vehicle operating performance	111
7.3.2	Verification of train operating performance	114
7.3.3	Verification of pedestrian comfort	116
7.3.4	Verification for other considerations	118
Chapter 8	Required Durability Performance and Verification	120
8.1	General	120
8.2	Required Durability Performance	121
8.2.1	Fatigue resistance	121
8.2.2	Corrosion resistance	122
8.2.3	Resistance to material deterioration	124
8.2.4	Maintainability	124
8.3	Verification of Durability	124
8.3.1	Verification of fatigue resistance	124
8.3.2	Verification of resistance to steel corrosion	127
8.3.3	Verification of resistance to material deterioration	130
8.3.4	Verification of maintainability	131
Chapter 9	Required Social and Environmental Compatibility Performance and Verification	134
9.1	General	134
9.2	Required Social and Environmental Compatibility Performance	134
9.3	Verification of Social and Environmental Compatibility	135
9.3.1	Verification of social compatibility	135
9.3.2	Verification of economic rationality	135
9.3.3	Verification of environmental compatibility	136
Chapter 10	Structural Members in General	138
10.1	Structural Members	138
10.2	General	138
10.2.1	Secondary stress	138
10.2.2	Stress concentration	139
10.2.3	Members with alternate stresses	139
10.2.4	Minimum plate thickness and corrosion	140
10.2.5	Curved members	140
10.2.6	Dynamic wind-resistant design of structural members	141
10.3	Frame Members with Axial Tensile Force	141
10.3.1	Slenderness ratio of members	141
10.4	Frame Members with Axial Compression Force	142
10.4.1	Width-thickness ratio of plate subjected to compressive stress and stiffened plate ..	142
10.4.2	Perforated plate	145
10.4.3	Influence of eccentric bending moment	146
10.4.4	Slenderness ratio of structural members	146
10.5	Frame Members with Bending	147
10.5.1	Width-thickness ratio of plate subjected to compressive stress and stiffened plate ..	147
10.5.2	Effective section	147

10.5.3	Overlapping flange	147
10.5.4	Effective section for shear forces	148
10.6	Steel Pipes	149
10.6.1	Radial thickness ratio	149
10.6.2	Stiffened member	149
10.6.3	Node structure	150
10.6.4	Curved tube	151
10.6.5	Steel pipe connections	152
Chapter 11	Joints	155
11.1	General	155
11.2	Joint Safety Requirements	155
11.3	Verification of Joint Safety	156
11.4	General Principles for Joints	156
11.4.1	Member joints	156
11.4.2	Mixed welded, high-strength bolted, and bolted connections	156
11.5	Welded Connections	157
11.5.1	Requirements	157
11.5.2	Safety verification of welded connections	158
11.5.3	Size of fillet welds and geometry and dimensions of welded connections	162
11.6	High-Strength Bolted Connections	165
11.6.1	Requirements for safety of high-strength bolted connections	165
11.6.2	Safety verification of high-strength bolted connections	166
11.6.3	Design characteristic values for verification of connection safety	172
11.7	Structural Details of High-Strength Bolted Connections	176
11.7.1	Bolts, nuts, and washers	176
11.7.2	Holes for bolts	177
11.7.3	Bolt length	178
11.7.4	Bolt spacing	178
11.7.5	End and edge distance	179
11.7.6	Minimum number of bolts	180
11.7.7	Filler plates	181
11.7.8	Angled and circular washers	181
11.8	Bolted Connections	182
11.8.1	General	182
11.8.2	Bolts, nuts, and washers	182
11.8.3	Structural details	183
11.9	Pin Connections	184
Chapter 12	General Considerations for Framed Structures	186
12.1	Scope	186
12.2	Member Section Design	186
12.2.1	General	186
12.2.2	Design of truss members	187
12.2.3	Design of rigid frame members	196
12.2.4	Design of arch members	197
12.2.5	Calculation of effective buckling length by eigenvalue analysis	204
12.3	Checking of Entire Structure	205
12.4	Constraint in the Transverse Direction	206
12.5	Camber	207

12.6	Members Considered as Substructure	207
12.7	Considerations of Torsion Acting on Steel Towers	209
Chapter 13	Plate Structures	211
13.1	General	211
13.2	Effective Width	212
13.3	Steel Girder Web	212
13.4	Plate Structure Subjected to Out-of-Plane Loading or Combined Out-of-Plane and In-Plane Loading	213
13.5	Other Plate Structures	213
13.6	Load Concentrate Point	214
13.7	Beam-to-Column Connection	214
13.8	Panel Connection	214
13.9	Cross Beam, Cross Frame, Lateral Bracing, and Diaphragm	215
13.9.1	General	215
13.9.2	Cross beams	216
13.9.3	Cross frames	216
13.9.4	Lateral bracing	216
13.9.5	Diaphragms	217
Chapter 14	Slab Design	219
14.1	General	219
14.1.1	Structural scope	219
14.1.2	Design action	219
14.1.3	Analytical procedure	219
14.2	Safety	221
14.2.1	Safety of slab	221
14.2.2	Out-of-plane shear	221
14.2.3	Out-of-plane bending	222
14.2.4	In-plane forces	223
14.2.5	Safety verification of slab	223
14.3	Serviceability	223
14.3.1	Serviceability of slab	223
14.3.2	Serviceability verification of slab	224
14.4	Fatigue Resistance	226
14.4.1	Fatigue resistance of slab	226
14.4.2	Fatigue due to out-of-plane shear	227
14.4.3	Fatigue due to out-of-plane bending	229
14.4.4	Influence of water	229
14.5	Corrosion Resistance and Resistance to Material Deterioration	230
14.5.1	Resistance to steel corrosion	230
14.5.2	Resistance to concrete deterioration	231
14.6	Slabs of Various Types	231
14.6.1	Reinforced concrete slab	232
14.6.2	Pre-stressed concrete slab	233
14.6.3	Steel-concrete composite slab	234
14.6.4	Orthotropic steel deck	235
Chapter 15	Design of Composite Girders	240
15.1	General	240
15.2	Strength of Composite Girder	241

15.2.1	Classification of cross sections	241
15.2.2	Design bending resistance	243
15.2.3	Verification of bending moment	246
15.2.4	Shear strength	246
15.2.5	Verification of shear	247
15.2.6	Verification of combined bending and shear	247
15.3	Structural Analysis and Resultant Force	249
15.4	Shear Connectors	250
15.4.1	General	250
15.4.2	Type of shear connectors	250
15.4.3	Ultimate limit state for shear connectors	251
15.4.4	Verification at safety limit state	252
15.4.5	Verification at fatigue limit state	253
15.4.6	Design strength of shear connectors	253
15.4.7	Influence of steel girder plasticity on horizontal shear force	258
15.5	Detailing of Shear Connectors	259
15.5.1	Headed stud connectors	259
15.5.2	Perforated-plate dowels	260
15.5.3	Block connectors	261
15.6	Verification of Crack Width in Composite Girders	261
15.7	Effective Width of Concrete Deck for Composite Girders	263

Chapter 1 General Provisions

1.1 Scope

This Design volume of the Standard Specifications for Steel and Composite Structures ("Specifications") describes the standard procedure for performance verification in the design of steel structures and composite girders ("steel and composite structures"). The Specifications also describe the structural details of the structure to be verified. The design step of verifying the effects of a large-scale earthquake (L2 earthquake) is described separately in the Seismic Design volume.

【Commentary】

These "Standard Specifications for Steel and Composite Structures" ("these specifications" hereafter) comprise six volumes: General Principles, Structural Planning, Design, Seismic Design, Construction, and Maintenance. This Design volume applies to the design of steel structures and composite girders ("steel and composite structures"). The structures considered in this volume are general steel structures, in which the structural material used for the main members is steel, and composite girders and columns comprising both steel and concrete. In the design of composite girders, the specifications [JSCE 2002a] and [JSCE 2002b] may be referred to instead of this volume.

In cases where the specifications given in this Design volume are insufficient and/or inappropriate for the structural design of a particular specific structure, it may be unnecessary to apply this volume if the required performance is verified through a full-scale experiment or model experiment that takes full account of the design actions, a numerical analysis method of certified accuracy and applicability, or a similar approach. In this case, however, the substance of this Design volume might be taken into account in the design of the structure while clarifying the accuracy and applicable scope of the performance verification method with respect to required performance at the design stage.

One of the design steps is verifying the effects of a large-scale earthquake, such as an earthquake producing Level 2 earthquake motion. This is described separately in the Seismic Design volume. If medium earthquakes, such as those producing Level 1 earthquake motion, are to be taken into account at the design stage, this Design volume may be used for performance verification because the relevant verification methods introduced here are applicable to such cases.

1.2 Terms and Definitions

1.2.1 Commonly used terms

(1) General terms relating to design

- 1) Performance-based design method: a design method in which there is no restriction on structural type and materials, design method, or construction method. The only requirement is that the designed structure meets the performance requirements. Specifically, it is a design method in which the specified performance of the structure is assured at each of the structural planning, design, construction, and maintenance stages once the objectives and functions of the structure have been clearly defined. That is, the performance of the structure is specified so as to fulfill its function.
- 2) Regulation-based design: a design method in which the structure or structural members

are designed based on specific design codes that specify suitable procedures, such as design calculations, structural materials, and their sizes.

- 3) Deemed to satisfy regulations: regulations in which one or more solutions that are deemed to satisfy the performance requirements are illustrated. These regulations may be adopted in cases where the method of verifying structural performance is not necessarily specified. These regulations specify structural materials and their sizes, procedures such as design calculations that are empirically regarded as correct, and other factors.
 - 4) Reliability-based design method: a design method in which the possibility of a structure/structural member reaching the limit state is estimated based on probabilistic theory.
 - 5) Limit-state design method: a design method in which a limit state to be verified is clearly specified and partial-factor design is adopted as the verification format. The partial-factor design format is classified as a Level 1 verification format from the reliability-based design viewpoint. Strictly speaking, partial-factor design is not equivalent to limit-state design, although the two are sometimes regarded as equivalent in Japan.
 - 6) Partial-factor design format: a design format incorporating certain partial factors in order to take into account uncertainties or scatter relating to actions??, geotechnical parameters, structural member size, structural analysis method, etc.
 - 7) Life-cycle cost: the total cost of structural planning, design, construction, maintenance, and demolition of a structure; in other words, the total amount invested over the complete life cycle of the structure.
 - 8) Design working life: the assumed period for which a structure fulfils its intended purpose without major repair and within the scope of the initially established maintenance plan. Design working life is determined at the design stage. Initially planned regular inspections and repairs are continued throughout the design working life.
 - 9) Durable lifetime: the period between entering service and the point in time at which the performance of the structure falls below requirements due to fatigue, corrosion, material deterioration, or other factors and the structure reaches its limit state.
 - 10) Objective: a common expression of the reason for building the structure. It is often desirable for the objective to be expressed with the word 'client' or 'user' as the subject of the sentence.
 - 11) Function: the role that a structure has to play in accordance with the objective.
 - 12) Review: a process carried out by an authorized third-party institution in order to determine whether the design process, from determination of the objective to verification, is proper or not.
 - 13) Authorization: the final determination by the third party brought in to perform a review.
 - 14) Certification: the act of the third party institution issuing a certificate once the structural design is determined to be proper.
- (2) Terms relating to performance
- 1) Performance: the behavior that the structure has to demonstrate in order to meet the objective or requirements.
 - 2) Required performance: the performance that the structure has to demonstrate in order to meet the objective.
 - 3) Performance item: itemization of required performance. For each item, a verification index is set. The index, generally, includes a specified limit state.

- 4) Performance level: the level of performance that is required of each structure. Performance level is determined for each required performance depending on its necessity.
 - 5) Safety: ability of a structure to protect the lives and assets of users and third parties.
 - 6) Serviceability: ability of a structure to perform such that allowed degrees of user-experienced displeasure or unease are not exceeded.
 - 7) Durability: ability of a structure or structural element to resist deterioration caused by repeated variable action and/or environmental action. In the case of steel and composite structures, corrosion of steel members caused by environmental action, fatigue phenomena caused by repeated variable action, and deterioration of concrete member materials and strength are considered.
 - 8) Restorability: ease with which a structure can be restored to its originally specified performance level after undergoing assumed actions that lead to deterioration of its performance level.
 - 9) Social and environmental compatibility: a measure of how a structure not only contributes to sound social, economic, and cultural activities but also minimizes stress on the surrounding social and natural environment.
 - 10) Constructability: a measure of how safe and assured construction work is during fabrication and erection.
 - 11) Initial soundness: the requirement that a structure performs, upon completion, in line with the level intended at the design stage.
 - 12) Maintainability: the ease of maintenance of a structure.
- (3) Terms relating to limit state
- 1) Limit state: a state in which the structure or structural element no longer meets the required performance.
 - 2) Safety limit state: a state resulting in collapse or other similar form of structural failure due to excessive deformation, displacement, vibration, or similar. The safety limit state is used as the limit state associated with structure safety. The term is often referred to as the "ultimate limit state" and so is used in the Seismic Design volume.
 - 3) Serviceability limit state: a state that corresponds to conditions beyond which the specified service requirements for the structure or a structural element are no longer met. The serviceability limit state is used as the limit state associated with the serviceability of a structure.
 - 4) Repair limit state: a state in which continued use of a structure damaged by expected action is possible after repairs using currently available repair methods, carried out at reasonable cost, and carried out within a reasonable period. The repair limit state is used as the limit state associated with ease of repair. In the Seismic Design volume, the term "damage limit state" is used in place of "repair limit state".
 - 5) Fatigue limit state: a state in which a structure or structural member suffers fatigue or failure as a result of repeating variable action. Fatigue limit state is used as the limit state corresponding to the fatigue durability of a structure.
- (4) Terms relating to verification
- 1) Performance verification: activities performed in order to verify that the designed structure satisfies all of the performance requirements. When the limit-state design method is adopted, the judgment entails comparing response values with the limit values of performance.
 - 2) Verification index: index used to express a performance item as a physical quantity. Verification indices are used in performance verification.
 - 3) Response value (Demand) S : physical quantity representing the response of the struc-

ture to an action.

- 4) Limit value of performance (Capacity) R : allowable limit of physical response to a corresponding structural response. This value is determined based on the required performance level.
 - 5) Statistical characteristic value: a value corresponding to the a priori specified fractile of the statistical distribution of a random variable such as a material property or action. The expected value and the mode of a random variable are regarded as statistical characteristic values.
 - 6) Optimization: the process of obtaining an optimal solution such that the objective function, including required performance, performance item, etc. as subordinate variables, becomes a minimum or maximum under restraint conditions.
 - 7) Partial factor: a factor assigned to each design value in order to consider its uncertainty. Five partial factors are generally used: an action factor, a material factor, a structural analysis factor, a structural member factor, and a structure factor.
 - 8) Structure factor: a factor that takes into account the importance of the structural, social, and economic effects that failure of the structure would have.
- (5) Terms relating to actions
- 1) Action: any effect that leads to deformation, displacement, constraint, or deterioration of a structure or structural element.
 - 2) Load: an assembly of mechanical forces directly acting on a structure. The forces are converted from actions through the analytical model. A load is used as an input datum for design calculations of the stress resultant, stress, displacement, and so on.
 - 3) Design value of action: a value obtained by multiplying the action factor by the characteristic value of the corresponding action.
 - 4) Direct action: an assembly of concentrated or distributed mechanical forces acting on a structure.
 - 5) Indirect action: the cause of deformations imposed on the structure or constrained in it.
 - 6) Environmental action: mechanical, physical, chemical, or biological action that may cause deterioration of the materials constituting a structure.
 - 7) Permanent action: action which is likely to act continuously throughout the design working life and for which variations in magnitude with time are small compared with the mean value.
 - 8) Variable action: action for which the variation during the design working life is not negligible in relation to the mean magnitude and is not monotonous.
 - 9) Primary variable action: one or one set of variable actions considered as the primary influences when load combinations are taken into account in performance verification work.
 - 10) Secondary variable action: an action considered secondary among the variable actions and that is additive to the combination of primary variable action and accidental action.
 - 11) Accidental action: action that rarely occurs on a structure over the design working life but which may cause serious damage if it does happen to occur.
 - 12) Action modifying factor: a factor for converting the standard or nominal value of action into a characteristic value.
 - 13) Action factor: a factor that takes into account the unfavorable deviation of statistical characteristic values of action, uncertainty relating to the action model, changes in action characteristics during the design working life, the influence of action characteristics on the relevant limit state of the structure, variations in environmental action, and so

on.

- (6) Terms relating to structural materials
 - 1) Characteristic value of material strength: a value corresponding to an a priori specified fractile of the statistical distribution of material strength. The statistical distribution is determined based on statistical data obtained from standardized material strength tests.
 - 2) Standard value of material strength: a value of material strength adopted in structural design specifications/standards other than "Standard Specifications for Steel and Composite Structures".
 - 3) Material strength modifying factor: a factor for converting the standard value of material strength into a characteristic value.
 - 4) Material factor: a factor that takes into account unfavorable deviation of statistical characteristic values of material strength, differences in material properties between experimental specimens and the real structure, the influence of material properties on the relevant limit state of the structure, changes in material properties over a given reference period, and so on.
 - 5) Design value of material strength: a value obtained by dividing the characteristic value of material strength by the corresponding material factor.
- (7) Terms relating to calculation of response value
 - 1) Factor for structural analysis: a factor used to take into account the accuracy of structural analysis methods applied in the calculation of the stress resultant and similar, uncertainties relating to the modeling procedure used for the structure, and so on.
- (8) Terms relating to capacity of structural member
 - 1) Structural member factor: a factor that takes into account the accuracy of structural resistance analysis methods applied in the calculation of load-carrying capacity, variations in structural member size, the importance of the role of the structural member, and so on.
 - 2) Design capacity of structural member: a value obtained by dividing the capacity by the structural member factor. Capacity is calculated by using the design values of strength materials.

1.2.2 Terms used in this Design volume

- (1) Primary member: a member whose failure would directly lead to loss of stability and/or function and failure of the whole structure.
- (2) Secondary member: a member that fulfills a secondary function and whose failure would not directly lead to loss of stability and/or function nor failure of the whole structure.
- (3) Structural detail: a design method agreed in response to a part that cannot be designed by applying a design calculation method and/or to a request made regarding construction to be considered at the design stage. A structural detail is a necessary condition for guaranteeing appropriate prior conditions for the design calculations.

【 Commentary 】

The terms commonly used in these specifications and principal ones used in the Design volume are defined here.

1.3 Notation

The following notation is defined for this specification. Only general notation is given.

(1) Action, sectional force, capacity and stress

F_k	Characteristic value of action
F_d	Design action
M	Bending moment
M_{sd}	Design bending moment
M_1, M_2	End moment
M_E	Lateral torsional buckling moment
M_u	Flexural capacity
M_{rd}	Design flexural capacity
M_y	Yield moment
M_p	Full plastic moment
N, P	Axial force
N_u, P_u	Axial capacity
N_{sd}	Design axial force
N_{rd}, P_{rd}	Design axial capacity
N_Y, N_y	Yield axial force
V	Shear force
V_{rd}	Design shear capacity
T	Torsional moment
T_{sd}	Design torsional moment
T_{rd}	Design torsion capacity
P_E, P_e	Euler buckling load
f_k	Characteristic value of material strength
f_d	Design material strength
f_{yk}	Characteristic value of tensile yield strength
f_{yd}	Design yield strength
f_{uk}	Characteristic value of tensile strength
f_{ud}	Design tensile strength
f'_{yk}	Characteristic value of compressive strength
f'_{yd}	Design compressive strength
f_{vyk}	Characteristic value of shear yield strength
f_{vyd}	Design shear strength
σ	Normal stress
τ	Shear stress
σ_{rd}	Design local buckling strength
τ_{rd}	Design shear strength
σ_{cr}	Buckling stress
τ_{cr}	Shear buckling stress
σ_E, σ_e	Euler buckling stress
σ_r	Residual stress
σ_u	Ultimate stress
σ_Y, σ_y	Yield stress

(2) Displacement and strain

u, v, w	Displacement in x, y, z direction
ε	Axial strain
ε_y	Yield strain
γ	Shear strain

ε_{st}	Starting hardening strain
E	Modulus of direct elasticity
G	Modulus of rigidity
E_{st}	Initial strain hardening coefficient
ν	Poisson's ratio
(3) Geometrical values	
A	Cross-sectional area
A_e	Effective cross-sectional area
$D = \frac{Et^3}{12(1-\nu^2)}$	Bending stiffness of plate
L, ℓ	Member length
I	Geometrical moment of inertia
$I_{\omega\omega}, C_{\omega}$	Bending torsional constant
J	St.Venant's torsional constant
$R = \frac{b}{t} \sqrt{\frac{\sigma_Y}{E} \frac{12(1-\nu^2)}{\pi^2 k}}$	Width-thickness ratio parameter
W	Sectional modulus
Z	Plastic sectional modulus
r	Radius of rotation (radius of gyration of area)
ℓ_e	Effective buckling length
ℓ_e/r	Slenderness ratio
b_e	Effective width of plate
t	Plate thickness
$\alpha = a/b$	Aspect ratio of plate (ratio of long side to short side)
k	Buckling coefficient
γ	Relative stiffness of stiffener
$\lambda = \frac{\ell_e}{r} \frac{1}{\pi} \sqrt{\frac{\sigma_Y}{E}}$	Slenderness ratio parameter
(4) Verification	
S, R	Response value, Limit value (Resistance)
S_d, R_d	Design response value, Design limit value (Design resistance)
γ_i	Structural factor
γ_a	Structural analysis factor
γ_f	Action factor (load factor)
γ_b	Structural member factor
γ_m	Material factor

【 Commentary 】

This is the principal notation used in these specifications. The SI system of units is adopted, although other practical systems may be used where values are quoted from other standards, papers, etc.

1.4 Basis of Design

1.4.1 Purpose of design

Steel and composite structures shall be designed so that they satisfy the required performance in all areas such as safety, serviceability, restorability, durability, and social and environmental

compatibility throughout their design working life.

【Commentary】

Steel and composite structures should conform to their purpose of use and should be both safe and also functional. To meet these requirements, steel and composite structures or structural members must be designed such that they meet the required performance in all areas such as safety, serviceability, restorability, durability, and social and environmental compatibility under the various actions that affect them during their construction and service periods. As stated in the General Principles volume, the design working life of a bridge is generally established at 100 years at present.

1.4.2 Verification of performance

- (1) During design, the performance required for steel and composite structures shall be defined clearly. Generally, required performance shall be established in the areas of safety, serviceability, restorability, durability, and social and environmental compatibility .
- (2) During design, a performance level shall be specified for each performance item and the performance level shall be verified for each performance item.
- (3) In general, verification indexes and limit states for the indexes shall be established. The performance of the structure shall be verified such that the response calculated by appropriate numerical analysis does not exceed the limit states.
- (4) For any verification not carried out by the method in (3) above, verification through experimental methods or adherence to specifications relating to structure details and materials can be considered a suitable means of performance verification.
- (5) In verifying performance, it shall be verified that the response value does not exceed the limit value at any time during the construction period and the design life.

【Commentary】

- (1) The first step at the structural planning and design stages is to determine the required performance of the steel or composite structure. However, there remain at present various opinions and arguments regarding the definition and classification of required performance; as yet, no consensus on these matters has been reached.

In [Ministry of Land, Infrastructure, Transport and Tourism (2002)], three performance requirements - that is, safety, serviceability, and restorability - are defined as the fundamental required performance of a structure. These three are subdivided according to the function of the structure. Social and environmental compatibility is a recent requirement associated with changing social and economic circumstances. This new fundamental performance requirement may become crucial from now on, although techniques for defining and estimating the relevant limit state are inadequate at present.

A commonly used verification method is to check that a response value is no greater than the limit value, but this may not be applicable where it proves impossible to define the limit state. In such cases, performance verification is carried out by optimizing the objective function, which is a function of the design variables [JSCE (2003a)].

The performance items corresponding to each of the basic performance requirements - safety, serviceability, restorability, and social and environmental compatibility - are listed in Table C1.4.1. In this table, the performance item "durability" is incorporated into the safety, serviceability, and restorability requirements as it is commonly related to these three basic performance requirements. These basic performance requirements are applicable not only to the structural design stage but also to the maintenance stage when the structure is in service.

In light of the current situation regarding the availability of verification techniques at the design stage as well as convenience for the design engineer, it may be more appropriate to use performance classifications that reflect the actual process of design specification, since structural design is not necessarily carried out according to classifications of required performance. Thus, the performance items corresponding to each basic performance requirement in Table C1.4.1 is covered in the volume indicated in the third column. The performance requirements listed in Table C1.4.2 are the ones established in this Design volume.

This classification relating to required performance is determined based on the following consideration.

① Safety

As safety performance items, the safety of the whole structure (structural safety) and safety with respect to members of the public in the vicinity of the structure (public safety) are established in these specifications. Structural safety includes action resistance performance, displacement and deformation performance, stability performance, etc. Structural safety is in fact the requirement to ensure overall safety of the structure under the severest expected action. Although it is desirable to verify the safety of the structure as a whole, the

Table C1.4.1 Basic performance requirements and examples of related performance items

Basic performance requirement	Performance item examples	Coverage in these specifications
Safety	Structural safety (resistance, stability, etc.)	Design volume: safety
	Public safety (damage to third party such as falling objects)	Design volume: safety
	Safety during earthquake (resistance, deformation capacity, stability)	(Other volume: Seismic Design volume)
	Safety during construction (resistance, stability, initial soundness)	Design volume: Constructability (Other volume: Construction volume)
Serviceability	Serviceability for users (vehicle operating performance, pedestrian comfort)	Design volume: serviceability
	Serviceability after earthquake (vehicle operating performance, pedestrian comfort)	(Other volume: Seismic Design volume)
	Serviceability for maintenance (ease of maintenance (inspection, painting, etc.))	Design volume: durability
Restorability	Restorability after earthquake (restoration of damage caused by earthquake)	Design volume: restorability (Other volume: Seismic Design volume)
	Maintainability (ease of repair after degradation with the passage of time and inspection)	Design volume: durability
Social and environmental compatibility	Social compatibility (consideration of social importance of structure)	Design volume: social and environmental compatibility
	Economic rationality (LCC, LCU)	Design volume: social and environmental compatibility
	Environmental compatibility (noise, vibration, negative environmental impact (LCA), aesthetics, etc.) Environmental compatibility during construction (noise, vibration, and negative environmental impact)	Design volume: social and environmental compatibility (Other volume: Construction volume)

Note) LCC: Life cycle cost LCU: Life cycle utility (social, economic utility during life cycle) ,

LCA: Life cycle assessment

Table C1.4.2 Classification of performance requirements in this Design volume

Performance requirement	Performance item	Example of check item	Example of verification index
Safety	Structural safety	resistance of structural member, resistance of whole structure, resistance of joint, stability, etc.	Stress resultant, stress
	Public safety	injury to users and third parties (falling object etc.)	-
serviceability	Vehicle operating performance	vehicle operating performance under usual conditions (soundness and rigidity of road) train operating performance and ride comfort under usual conditions	Road surface flatness, deformation of main girder
	Pedestrian comfort	pedestrian comfort under usual conditions (walking-induced vibration)	Natural frequency of main girder
Restorability*	Restorability after earthquake	level of damage (ease of restoration)	Response value (damage level)/limit value of performance (damage level)
Durability	Fatigue resistance	fatigue durability against variable actions	Equivalent stress range/allowable stress range
	Corrosion resistance	rust prevention and corrosion protection performance of steel material	Corrosion environment and painting specification, LCC
	Resistance to material deterioration	concrete deterioration	Water-content ratio, cover of concrete
	Maintainability	ease of maintenance (inspection, painting, etc.) and ease of restoration	-
Social and environmental compatibility	Social compatibility	appropriateness of partial factor (consideration of social importance of structure)	Partial factor (structural factor), etc.
	Economic rationality	social utility during life cycle of structure	LCC , LCU
	Environmental compatibility	noise, vibration, environmental impact (CO ₂ emissions), aesthetics, etc.	Noise and vibration levels for surrounding residents, life-cycle CO ₂ , aesthetic reaction to structural shape and color, monumental aspect, etc.
Constructability*	Safety during construction	safety during construction	Stress resultant, stress, deformation
	Ease of construction	ease of fabrication and construction work	

* Note: Actual verification methods for restorability and Constructability are prescribed in the Seismic Design and Construction volumes, respectively, although the required performance is established here in the form of these performance requirements.

conventional method generally used for verification is to determine whether the structural member(s) and their connections reach the required level of resistance. Public safety is the requirement to avoid injury or damage to any public third party as a result of the existence of the structure, such as through the collapse of ancillary equipment (e.g., highway or railway signs), the dropping out of high-tension bolts that have suffered delayed fracture, the stripping away of concrete fragments from slabs, and so on. This performance item is established in consideration of the environment around the structure according to demand, so no verification method is specified in this Design volume.

② Serviceability

Serviceability is the ability of a structure to perform such that users suffer no problems or discomfort. Performance items relating to serviceability should be established according to the utilization pattern of the structure. In this Design volume, vehicle and train operating

performance (performance relating to vehicular traffic) and pedestrian comfort (performance relating to walking) are considered as performance items with respect to bridges. Vehicle operating performance is specified for highway bridges and train operating performance for railway bridges. However, the former is meant in this Design volume when the term "vehicle operating performance" is used.

Some structural engineers might consider that the performance item representing the ease of structure maintenance should be included as part of "serviceability", as shown in Table-commentary 1.4.1. However, this performance item is not treated as part of serviceability in this Design volume; only the performance items relating to users are included. Maintainability, representing the ease of maintenance of a structure, is regarded here as one of the performance items relating to "durability", with which it is closely related. Furthermore, the influence of the structure on the surrounding social and natural environment is treated as one of the performance items relating to "social and environmental compatibility" in this Design volume, although this performance item is sometimes classified as part of "serviceability".

In addition to the vehicle operating performance, train operating performance, and pedestrian comfort, "serviceability" also includes the requirement to prevent excessive deformation and/or appearance degradation of the structure (or its structural members), to secure water-tightness, and other performance items, so as to ensure that no unpleasant and/or harmful effects are caused for users. As described above, the performance requirement "serviceability" is defined here in terms of bridge structures. However, the definition sometimes differs for structures other than bridges. For example, in the case of port and harbor structures, serviceability is established as a performance requirement directly connected to the functioning of the structure and "serviceability" is then defined as the requirement that users can utilize the structure without any inconvenience. In this case, the requirement is that any damage to functionality caused by expected actions should be limited to that which can be restored by small and rapid repairs. Therefore, "serviceability" has to be defined according to the conditions of use and utilization patterns of a particular structure.

③ Restorability

"Restorability" represents the ease with which a structure can be restored to its originally specified performance level after undergoing assumed actions that lead to performance deterioration. This performance requirement is generally assumed to be relevant in the case of exceptional actions such as earthquakes. Restorability of damage caused by normal actions is treated as one of the performance items in "durability," because it is closely related to the ease of maintenance of a structure.

Performance in earthquakes is essentially part of required performance relating to structural design. However, the design philosophy and verification techniques for earthquake performance are generally recognized as special. And it is also recognized that separation of the Design volume and the Seismic Design volume is more convenient for structural engineers in practice. Consequently, the volumes are in fact separated and performance verification against performance items such as safety under earthquake motion, serviceability after an earthquake, and restorability after an earthquake - especially Level 2 earthquake motion - is carried out using the Seismic Design volume, as shown in Table C1.4.1. Where a performance verification is carried out against Level 1 earthquake motion, the Design volume may be used because applicable verification methods are described in this volume.

In this Design volume, "restorability after an earthquake" does not need to be taken into consideration because no earthquake damage will result if the structure is designed such that the stress resultant remains less than the yield value. It is, however, established as one

of the performance items relating to "restorability". In cases where slight damage is allowed to be caused by Level 1 earthquake motion, however, verification of "restorability after an earthquake" is essential. For this purpose, "restorability" is prescribed in this volume as shown in Table C1.4.2. An actual verification method for restorability is given in the Seismic Design volume.

④ Durability

"Durability" is established as a performance requirement in this Design volume though it is not included in Table C1.4.1 as a basic performance requirement. The reasons for this are as follows.

Properly speaking, it may be reasonable to take account of performance deterioration over time in verifying the basic performance requirements such as safety, serviceability, and restorability throughout the design working life. There exists an assertion that the durability of structure has to be ensured by satisfying these three fundamental required performances during its design working life and thus durability must be treated differently from the safety, serviceability and restorability [JSCE (2002b), JSSC (2001)]. However, securing of durability is extremely important for the steel and composite structures as the control of performance degradation as a function of time elapsed caused by variable action which acts on a structure repeatedly and/or environmental one may seriously influence on the physical working life of structure. Therefore, "the control of performance degradation as a function of time elapsed caused by variable action which acts on a structure repeatedly and/or environmental one" is regarded as being equal to the verification of durability and durability is established as one of the important required performances in this Design volume. Though degradation of performance over time is closely related to all of the basic performance requirements, a general approach is to verify durability separately from other performance requirements from the viewpoint of performance verification methodology. In other words, in practice, if the verification entails controlling the performance degradation over time such that it is less than an a priori prescribed level, the verification of safety, serviceability, etc. can generally be carried out without any consideration of degradation. This former verification that degradation does not exceed a certain level is regarded as a verification of durability.

"Durability" is defined as the ability of a structure or structural element to resist deterioration caused by repeated variable actions and/or environmental action [JSCE (2003a)]. The verification of durability entails ensuring that deterioration of safety, serviceability, etc. over time is held to less than an a priori prescribed level. Actual performance items relating to "durability" in these specifications are fatigue resistance, corrosion resistance, and resistance to material deterioration. Although the verification of fatigue resistance can be regarded as part of the verification of safety, because fatigue failure of a structural member is checked as part of the durability verification, fatigue resistance is treated as a performance item relating to durability in this Design volume. Furthermore, the ease of inspecting and repainting a structure, the ease of repairing damage, and so on are considered as part of a structure's maintainability, which is included among performance items relating to "durability" because these items greatly influence the durability of a structure.

⑤ Social and environmental compatibility

"Social and environmental compatibility", as shown in Table C1.4.1, has come to be considered important as changes in social and economic circumstances have taken place. Performance items relating to this performance requirement have been established: social compatibility, economic rationality, and environmental compatibility. Social compatibility is the performance item used for verification of the structure in consideration of its social

importance. This performance item is required if the importance of the structure is considered in selecting the verification method or setting the partial factors. Economic rationality is the performance item used to verify which structure is the best from the viewpoint of life-cycle cost. At present, it is impossible to estimate the effect that the existence of a structure will have on people's social and economic life using a measure such as "utility". However, if a method of estimating "utility" is fully developed, it may be desirable to design a structure so that its life-cycle utility is maximal.

"Social and environmental compatibility" is verified by optimizing an objective function that is a function of several performance requirements based on economic and technical viewpoints.

⑥ Constructability

"Constructability" represents performance during fabrication and erection of a structure, such as safety, ease of fabrication and erection, ease of construction quality control, and so on. This is one of the important performance requirements that must be taken into account at the design stage, so it is established as one of the performance requirements in this Design volume. An actual verification method for Constructability is given in the Construction volume. Consideration of initial soundness, which is one of the important performance items relating to "Constructability" [JSCE (2003a)], is also described in the Construction volume and not the Design volume because it must be taken into account at the construction stage.

Among the six performance requirements ①~⑥ above, there are some performance items for which relevant limit states have been clearly determined, such as structural safety in the safety performance requirement, vehicle operating performance and pedestrian comfort in the serviceability performance requirement, etc. On the other hand, it is difficult to determine a relevant limit state for social and environmental compatibility, for example. Where limit states have been determined, performance verification is carried out quantitatively. In other cases, the quantitative performance verification is replaced by an attempt to optimize the objective function.

(2) Where a verification as to whether a designed steel or composite structure satisfies the perfor-

Table C1.4.3 Limit states for each performance item

Required performance	Performance item	Limit state
Safety	structural safety public safety	Safety limit state or ultimate limit state; (public safety is not established in this Design volume.)
Serviceability	vehicle operating performance pedestrian comfort	Serviceability limit state
Restorability	restorability after earthquake	(restorability limit state or damage limit state [in Seismic Design volume])
Durability	fatigue resistance	fatigue limit state
	corrosion resistance	
	resistance to material deterioration	A certain state which may threaten to damage the other limit states
	maintainability	Corresponding limit state is not established in this Design volume
Social and environmental compatibility	social compatibility economic rationality environmental compatibility	Corresponding limit states are not established in this Design volume
Constructability	safety during construction ease of fabrication	Corresponding limit states are not established in this Design volume

mance requirements is carried out, the general procedure is to verify whether the limit state corresponding to the a priori required performance level is reached or not. The term "limit state" as used here means the itemized limit state established with respect to each performance item for an individual performance requirement. If this limit state is specifically defined, verification based on the limit state design method is possible. Each performance item and its respective limit state as adopted in this Design volume is shown in Table C1.4.3. Although the ideal would be to establish a limit state for every performance item, it is currently only possible to establish limit states for structural safety, serviceability, restorability, and fatigue resistance; there are no methods at present for setting the others. As noted in the commentary to "1.2 Terms and Definitions", the limit state for safety is defined so that it includes not only structural safety but also public safety. However, it is not possible at present to determine a limit state for public safety. Only ultimate limit states that are conventionally adopted are considered here. Corrosion resistance and resistance to material deterioration, which are part of the durability performance requirement, are regarded as having limit states because degradation of performance may threaten to damage other limit states.

As the basis for verification in performance-based design, the design response value must be no more than the design limit value of performance under the assumption that these two values are calculated using partial factors for each performance item. Fig.C1.4.1 illustrates the framework of performance verification. In cases where the establishment of a limit state is impossible, performance verification is carried out by optimizing an objective function such as cost, utility, etc., which is a function of the design variables.

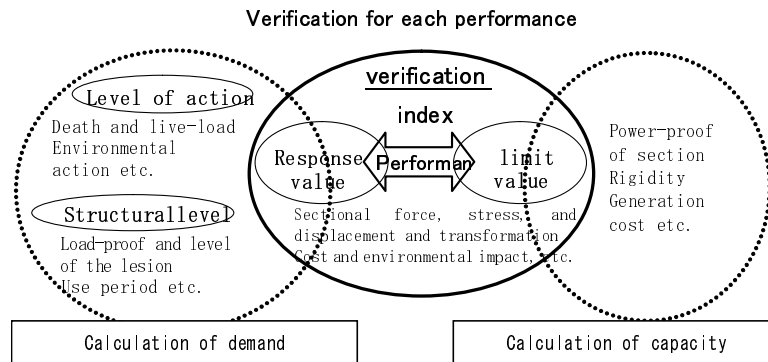

Fig.C1.4.1 Framework of performance verification

- (3) In calculating response values, it is necessary to select a structural model and a structural analysis method capable of appropriately estimating the performance of the designed structure. With respect to structural analysis, linear methods such as beam theory, grid theory, and so on have conventionally been adopted because they offer convenience in considering load combinations by simply summing the effect of dead load, live load, etc. With recent remarkable developments in computer techniques, advanced methods such as finite element analysis (in which a three-dimensional arrangement of many structural members including the floor slab is taken into account), finite displacement analysis (where the effect of geometric nonlinearity is considered), dynamic analysis, and others have come into frequent use. The most suitable analysis method should be selected according to the type of structure and the purpose of the verification. It should be noted that a fully accurate solution can not be obtained, even when using advanced computer-based structural analysis methods, if the modeling of loads applied by actions and structural shapes is not appropriate. Further, note that careful estimation and in-depth discussion of the stress results obtained by, for example, finite element analysis, using shell or solid elements is essential to obtaining reasonable results.

In this Design volume, a practical verification method corresponding to each performance requirement is prescribed in the chapters noted below.

- Verification for safety: Chapter 6 Demand for Safety and Verification
- Verification for serviceability: Chapter 7 Required Serviceability Performance and Verification
- Verification for durability: Chapter 8 Required Durability Performance and Verification
- Verification for social and environmental compatibility: Chapter 9 Required Social and Environmental Compatibility Performance and Verification.

As for joints, floor slabs, and composite structures, all design-related provisions such as verification method, structural details, etc. are specified in the relevant chapter, because giving the provisions from the viewpoint of the verification method for the performance requirements may lead to confusion. Verification methods for restorability and Constructability are not given in this Design volume; instead they are prescribed in the Seismic Design volume and the Construction volume, respectively.

- (4) Where it is not possible to calculate a response value using a numerical analysis method or where the definition of a limit state is not possible, verification through experimental methods or adherence to specifications relating to structural details and materials can be considered a suitable means of performance verification.

1.4.3 Verification method

- (1) Verification shall be based on the partial factor method on the basis of reliability theory and, as a standard design procedure, it shall be based on the limit-state design method.
- (2) In general, verification shall be based on design responses to design actions, design limits as determined by design material strengths, and individual partial factors. The performance of the structure shall, in general, be verified using Equations (1.4.1) and (1.4.2):

$$\gamma_i \frac{S_d}{R_d} \leq 1.0 \quad (1.4.1)$$

$$\gamma_i \frac{\sum \gamma_a \cdot S(\gamma_f \cdot F_k)}{R(f_k/\gamma_m)/\gamma_b} \leq 1.0 \quad (1.4.2)$$

- where ,
- R_d : design resistance
 - f_k : characteristic value of material strength
 - γ_m : material factor
 - γ_b : structural member factor
 - $R(\dots)$: function for calculating limit value of structure from material strength
 - S_d : design response
 - F_k : individual characteristic value of action
 - γ_a : structural analysis factor
 - γ_f : action factor corresponding to each action (load factor)
 - $S(\dots)$: function for calculating response value of structure from action
 - γ_i : structural factor

- (3) During design, a verification shall be carried out for every limit state that can be considered.

【 Commentary 】

- (1) Verification shall be based on the partial factor method according to reliability theory. The safety and serviceability limit states are a basic consideration and both fatigue and deterioration limit

states must be considered with respect to durability.

In general, reliability-based verification formats are classified into three categories from the point of view of the accuracy of the relationship between failure probability and the reliability measure used in each [e.g. JSSC (2001)]. In this Design volume, the Level-1 verification format is adopted. This format is based on the partial factor method and has commonly been used in general structural design.

- (2) The performance of a structure should, in principle, be verified using Equation (1.1.1), which includes one factor (structural factor γ_i) determined in consideration of the structural, social, and economic effects that failure of the structure would have. Regardless of the structural analysis method used, the load effect, stress resultant, stress, deformation, etc. can be adopted as the design values of R_d and S_d corresponding to the relevant performance items when this equation is used. However, given present practice whereby design calculations are generally carried out using linear analysis methods and the performance verifications are carried out not for the whole structure but for each of its structural members, the rather more convenient Equation (1.4.2) can be used. This is a performance verification format based on multiple partial factors and is easier to implement than Equation (1.4.1) when calculating design values R_d and S_d .

In Equation (1.4.2), partial factors $\gamma_f, \gamma_m, \gamma_a$, and γ_b correspond to the action factor, material factor, structural analysis factor, and structural member factor, respectively. These factors must be determined in consideration of unfavorable deviations from characteristic values, uncertainties in computational accuracy, discrepancies between design and practice with respect to actions or structures and structural material strengths, etc.

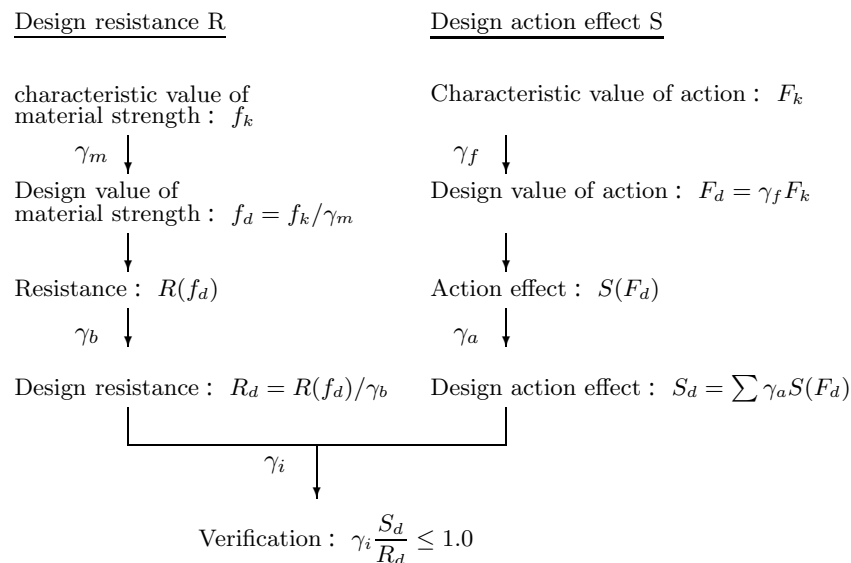

Fig.C1.4.2 Concept of verification of safety relating to structural resistance

In the design of steel and composite structures, the ideal would be for the type, shape, and size of the structure to be determined such that the probability of demand exceeding capacity is below an a priori prescribed value. At present, however, the calculation of such a probability remains extremely difficult and is recognized as impossible in practice. Therefore, this Design volume prescribes Equation (1.4.2) as the verification format to check whether the required performance of a structure or its structural members is met or not.

As an example of the process, Fig.C1.4.2 outlines the verification of safety relating to structural resistance based on Equation (1.4.2) [Steel and concrete common structural design standards Subcommittee (1992)].

In carrying out a verification based on Equation (1.4.1) or (1.4.2), the precision of the values given on the left side of each equation should be two significant digits. Thus, the design response value, design limit value, etc., are obtained to three significant digits.

1.4.4 Partial factors

- (1) Partial factors in a verification shall be determined based on the concept given in (2) and (3).
- (2) The material factor, structural member factor, structural analysis factor, and action factor shall be determined in consideration of 1) unfavorable deviations from characteristic values, 2) uncertainties in computational accuracy, and 3) discrepancies between design and practice with respect to actions or structures and materials.
- (3) The structural factor shall be determined as per the provisions of Section 1.5 below.

【Commentary】

In this Design volume, the required partial factors are specified in the chapters listed below. Standard values of these partial factors used in the verification of safety, serviceability, and durability are listed in Table C1.4.4. Values of the structural factor are given in Table C1.5.1.

Structural factor: Chapter 1 General Provisions, 1.5 Structural Factor

Action factor: Chapter 2 Actions

Material factor: Chapter 3 Materials

Structural analysis factor: Chapter 4 Structural Analysis

Structural member factor: Chapter 5 Structural Member Resistance

Table C1.4.4 Standard values of partial factors

Performance requirement (performance item)	Action factor γ_f	Structural analysis factor γ_a	Material factor γ_m	Structural member factor γ_b
Safety (structural safety)	1.0 ~ 1.7	1.0 ~ 1.1	1.0 ~ 1.05	1.0 ~ 1.3
Serviceability (vehicle operating performance and pedestrian comfort)	1.0	1.0	1.0 ~ 1.05	1.0
Durability (fatigue resistance)	1.0 ~ 1.1	1.0	1.0	1.0 ~ 1.1

When the partial factor design method is used as the verification format, reliance is placed on rational decision making by the design engineer as to whether each partial factor should be further subdivided or whether some partial factors can be lumped together. Note that in some other design standards, various views about this decision process have been proposed and/or adopted.

1.4.5 Modification factors

- (1) The specification provides for two modification factors, namely a material modification factor and an action modification factor.
- (2) The action modification factor shall be defined for converting a specified or nominal action value into a characteristic action value.
- (3) The material modification factor shall be defined for converting a specified value of material strength into a characteristic value of material strength.

【Commentary】

In the case that a specified or nominal value is used besides characteristic values relating to action

and/or material strength at present, the relevant characteristic value should be determined by adjusting the specified or nominal value with a modification factor.

1.5 Structural Factor

Structural factor γ_i shall be determined according to structural importance and also the social and economical impact of the structure reaching its limit state.

【Commentary】

The structural factor, which is used to take into account the importance of the structure, includes the social impact of the structure reaching its limit state, the structure's relevance to disaster prevention, and economic factors such as the cost of rebuilding or repairing the structure if it reaches its limit state. Basically, the value of the structural factor should be determined according to the wishes of the owner of the structure, because it is impossible to determine it theoretically based on reliability theory. Once the structural factor has been determined, social compatibility as prescribed in "Chapter 9 Required Social and Environmental Compatibility Performance and Verification" must be considered carefully.

The standard values given in Table C1.5.1 are generally adopted for the structural factor.

Table C1.5.1 Standard values of structural factor

Performance requirement (performance item)	Structural factor γ_i
Safety (structural safety)	1.0~1.2
Serviceability (vehicle operating performance and pedestrian comfort)	1.0
Durability (fatigue resistance)	1.0

References in Chapter 1

- Railway Technical Research Institute (1992) : Design Standards for Railway Structures and Commentary, Steel and Composite Structures .
- Japan Society of Civil Engineers(1992) : General principles for the limit state design of steel and concrete structures, Journal of Structural Mechanics and Earthquake Engineering, JSCE, No.450/I-20, pp.13-20.
- Japan Society of Civil Engineers (1997a) : Design Code for Steel Structures, PART A; Structures in General.
- Japan Society of Civil Engineers (1997b) : Design Code for Steel Structures, PART B; Composite Structures.
- Japanese Society of Steel Construction (2001) : Guidelines for Performance-based Design of Civil Engineering Steel Structures, JSSC Technical Report No. 49.
- Japan Road Association (2002) : Specifications for Highway Bridges and Commentary I Common Specifications, II Steel Highway Bridges.
- Ministry of Land, Infrastructure, Transport and Tourism (2002) : Design basis for civil and architectural engineering structures.
- Japan Society of Civil Engineers (2002a) : Standard Specification for Concrete Structures, Structural Performance Verification Volume.
- Japan Society of Civil Engineers (2002b) : Guidelines for Performance Verification of Hybrid Structures (tentative).
- Japan Society of Civil Engineers (2003a) : Towards establishment of performance-based design system for steel structures.
- Japan Society of Civil Engineers (2003b) : Comprehensive design codes (tentative) code PLATFORM ver.1.
- ISO(1998) : ISO2394 International Standard, General Principles on Reliability for Structures .

Chapter 2 Actions

2.1 General

- (1) In the design of steel and composite structures, actions expected to act on a structure during the construction period and during the design working life shall be determined according to the required performance.
- (2) Actions are all causes of deformation, displacement, constraint, and deterioration of a structure or structural member, as indicated below.
 - Direct action: an assembly of concentrated or distributed mechanical forces acting on a structure.
 - Indirect action: the cause of deformations imposed on the structure or constrained in it.
 - Environmental action: mechanical, physical, chemical, or biological action that may cause deterioration of the materials constituting a structure.
- (3) A load is defined as an assembly of mechanical forces acting directly on a structure. These forces are converted from actions through the analytical model. A load acts as an input datum for design calculations yielding the stress resultant, stress, displacement, and so on.

【 Commentary 】

- (2) Actions are categorized as direct, indirect, or environmental according to the way in which they influence a structure, as prescribed in Article 2.1 (2). But they may also be classed as permanent, variable, or accidental according to their frequency of occurrence, duration, and pattern of fluctuations and as static, dynamic, or repeating based on how the structure responds to them. In this clause, actions are considered as direct, indirect, and environmental so as to clarify the difference between actions and loads. Other classifications of actions are considered in Article 2.2 "Kinds of Actions".
- (3) A load is defined as an action in the form of forces acting directly on the structure. The relationship between action and load is explained in Fig.C2.1.1.

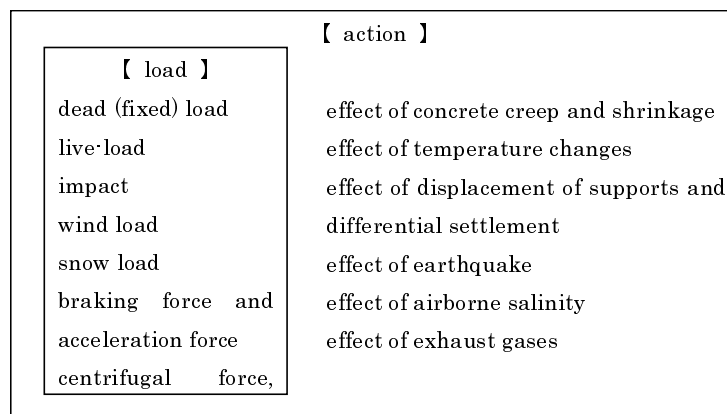

Fig.C2.1.1 Conceptual diagram of relationship between action and load

2.2 Kinds of Actions

- (1) In the design of steel and composite structures, actions shall be properly determined in correspondence with the verification items and the relevant structural members.
- (2) Actions are classified into three classes according to their characteristic occurrence frequency, duration, and fluctuation, as defined below.
 - Permanent action: action that is likely to act continuously throughout a given reference period and for which variations in magnitude with time are small compared with the mean value.
 - Variable action: action for which the variation in magnitude with time is neither negligible in relation to the mean value nor monotonic.
 - Accidental action: action that is unlikely to occur with a significant value on a structure over a given reference period and which may cause a serious damage to a structure if it does happen to occur.
- (3) Actions are classified into three classes according to the characteristics response of a structure to them, as defined below.
 - Static action: action that does not cause significant acceleration of the structure or structural members.
 - Dynamic action: action that may cause impulse acceleration or other significant acceleration of the structure or structural members.
 - Repeating action: action that may result in fatigue damage.

【 Commentary 】

The relationships between actions prescribed in Articles 2.2 (2) and (3) are shown in Table C2.2.1. These relationships may be reconsidered if sufficient investigation is carried out, because an action's frequency of occurrence and duration might be expected to depend on the type of structure, conditions at the location of the structure, and the structure's surroundings. Action values are prescribed in Article 2.4. Environmental actions that may lead to deterioration of materials constituting a structure are summarized in list form in Table C2.2.2.

2.3 Combinations of Actions

In a typical case of structural design, the combinations of actions shown in Table 2.3.1 shall be considered. In a case where an unusual combination of actions might be anticipated, action combinations aside from those listed in Table 2.3.1 may be taken into consideration according to the judgment of the responsible chief engineer.

Table 2.3.1 Combinations of actions

Required performance	Combination of actions
Safety	Permanent actions+Primary variable actions+Subsidiary variable actions
	Permanent actions+Accidental actions+Subsidiary variable actions
Serviceability	Permanent actions+Variable actions
Durability	Permanent actions+Variable actions

【 Commentary 】

Table C2.2.1 Kinds of action

	direct action	indirect action	environmental action
permanent action	(1) dead load (2) earth pressure (3) prestressing force	(18) effect of concrete shrinkage (19) effect of concrete creep	(23) effect of airborne salinity (24) effect of exhaust gases (25) effect of carbon dioxide concentration (26) effect of acid concentration (27) effect of drying and wetting (28) effect of sunshine
variable action	(4) live load (static, dynamic, repeating) a) moving load of vehicles b) railway loading c) crowd loading (5) impact load (static, dynamic) (6) flowing water pressure (static, dynamic) (7) hydrostatic pressure (8) buoyancy or uplift (static) (9) wind load (static, dynamic) (10) snow load (static) (11) braking force, acceleration force (static, dynamic) (12) centrifugal force (static) (13) longitudinal load imposed by long welded rail (static) (14) lateral train load and transverse wheel thrust (static) (15) wave pressure (static, dynamic)	(20) effect of temperature changes (static) (21) effect of displacement of supports and differential settlement (static)	(29) effect of freezing
accidental action	(16) erection-related force (17) collision force	(22) effect of earthquake	(30) effect of fire

Table C2.2.2 Environmental actions that may cause deterioration of materials constituting a structure

deterioration phenomenon		weather conditions	salinity supply	moisture supply	others
corrosion	corrosion	temperature, humidity, rainfall, wind	airborne salinity, seawater splashing, de-icing agents	rainfall, seawater splashing	sulfur oxide supply
	corrosion of reinforcement bars caused by percolating salinity	temperature, humidity, rainfall, wind	airborne salinity, seawater splashing, de-icing agents	rainfall	
material deterioration	alkali-aggregate reaction* ¹	temperature, humidity	airborne salinity, seawater splashing, de-icing agents		alkali supply
	freezing	temperature, temperature change, sunshine		excess moisture, rainfall	

*1 : As environmental action cannot be controlled, it is usual to control the total alkali content of the materials used in construction.

The value of each of the actions described in Table 2.3.1, consisting of permanent actions, primary variable actions, subsidiary variable actions, and accidental actions, is specified in Article 2.4.

A primary variable action is one or a set of variable actions considered the primary influence when combined loading is taken into account during performance verification work. A subsidiary (secondary) variable action is an action considered secondary among the variable actions; it is added to the combination of primary variable actions and accidental actions. Accordingly, the probability of a subsidiary variable action of the design value occurring should be greater than that of a primary variable action of the design value occurring, considering the probability of both variable actions occurring simultaneously with their extreme values.

Under certain circumstances, particularly large design values have to be given to multiple variable actions or combined variable and accidental actions when combinations of actions are considered. In this case, the engineer(s) in charge must determine the kind of actions to be combined and their design values.

In structural analysis, combinations of actions are generally treated by summing up the loads resulting from all actions, the design values of which are set sufficiently on the safe side. This approach may not give rise to problems, because the calculation gives a result that is safer than the actually designed structure. However, care must be taken not to accept this as a universal truth [JSCE (1998)]. Rather, where combinations of actions are considered, the inherent characteristics of each action must be carefully considered. In a case where static and dynamic actions are combined, for example, careful discussion is necessary as to whether any structural deformation caused by the combined action is accurately simulated or not. It is important to recognize that the stress resultant and deformation caused by the combination of a static action with a dynamic one are not simple sums but in fact nonlinear functions of the stress resultant and deformation caused by each action.

2.4 Action Values

2.4.1 General

- (1) The values of permanent actions and primary variable actions that are considered when verifying safety against structural failure or collapse may be statistical characteristic values obtained as an a priori specified fractile of construction period and design lifetime largest or smallest value probability distribution. The accidental action value may be taken to be the previously occurring largest value. The value of subsidiary variable action shall depend on which action combination is taken into account.
- (2) The action value considered when verifying serviceability shall be the value expected to be observed frequently during the construction period and the design working life. This value shall be determined depending on the required performance and the relevant action combination.
- (3) The value of action considered when verifying durability shall be determined by taking into account the variability of action during the design lifetime.

【Commentary】

- (1) In considering the limit state of a structure relating to safety against failure or collapse, the structural state of interest is one where functionality and stability have been seriously damaged by failure, deformation, displacement, etc. Therefore, the action values to be adopted in verifying safety against failure or collapse must be those that are likely to have the most serious influence on the structure during its construction and over its design working life. In general, the design values of permanent actions and primary variable actions are set at the maximal or

minimal values for an action return period longer than the design working life. A statistical characteristic value obtained from the lifetime maximal or minimal distribution of actions should be adopted as the action value, although current statistical data are not necessarily adequate for determining the probability distribution. Here, the decision as to what percentage fractile value is appropriate as the statistical characteristic value is left to the judgment of the design engineer. In general, 5~10% excess probability (in the case of a distribution of maximal values) or non-excess probability (in the case of minimal values) is considered appropriate. However, where it is not reasonable to calculate this fractile because the available statistical data are insufficient or data measurement accuracy is low, or where adoption of this fractile value is not desirable because action variability is extreme (for example, action values relating to earth pressure), the expected value of the lifetime maximal or minimal action distribution may be adopted instead. As for accidental action values, the concept of the largest past value - as commonly used in the seismic design standards of Japan and the United States of America - is introduced here because a usable and understandable determination method is required in situations where a statistical estimation is impossible.

In general, it is rare to consider only one variable action in design. That is, the simultaneous occurrence of multiple variable actions is commonly considered at the design stage. When this is the case, the likelihood of all the variable actions taking their maximal or minimal values simultaneously may not be high, so it is rational to make some adjustment for the combined case. Accordingly, variable actions are classified into primary and subsidiary ones, with the design value of the former taking their expected maximal or minimal values and the latter taking values determined appropriately according to which action (primary variable or accidental) they are combined with. The design value of a variable action treated as a subsidiary variable action may be lower than one adopted as a primary action.

- (2) An action with a value that is expected to be observed frequently, as is to be considered when verifying serviceability, is one for which no limit state (such as yielding of a steel member, excessive cracking of concrete, harmful deformation of structure, etc.) is expected to be reached as long as the action does not exceed this value. Such values should be determined mainly for permanent and variable actions depending on the characteristics of the structure, the type of action, and the limit state under consideration.
- (3) All of the permanent actions, variable actions, and accidental actions must be considered when verifying durability. Steel corrosion and material deterioration of concrete members under environmental action and the loss of resistance caused by fatigue should be taken into account when assessing durability. Action values are to be determined according to changes and fluctuations in environmental action over the design working life.

2.4.2 Dead load

- (1) The dead load shall be the action caused by the weight of the structural elements and ancillary facilities themselves.
- (2) The characteristic value of dead load shall be calculated by reading off the dimensions of structural members precisely and by evaluating the unit weight of the structural materials properly.

【 Commentary 】

- (1) The dead load is subdivided into two components: the fixed dead load and the additional dead load.
- (2) The characteristic value of the dead load is to be determined in consideration of the actual

weight of the structure and any variations in this weight. Table-commentary 2.4.1, which lists the standard unit weight values for various structural materials, may be used to determine the action value of the fixed dead load. The action value for the additional dead load is to be determined by taking account of any variations.

Table C2.4.1 Standard unit weight values for various structural materials

structural material	unit weight (kN/m ³)	structural material	unit weight (kN/m ³)
steel, cast steel, and steel forging	77.0	concrete	22.5 ~ 23.0
cast iron	71.0	cement mortar	21.0
aluminum	27.5	wood	8.00
reinforced concrete	24.0~24.5	bitumen material	11.0
prestressed concrete	24.5	asphalt concrete pavement	22.5
reinforced lightweight aggregate concrete (all aggregates are lightweight aggregates)	18.0	lightweight aggregate concrete (all aggregates are lightweight aggregates)	16.5

2.4.3 Earth pressure

Earth pressure shall be determined according to the required performance by considering the type of structure, structural rigidity, and type of subsoil.

【Commentary】

Several formulas have been proposed for calculating earth pressure. It is important to select the most suitable of these in consideration of the behavior of the designed structure.

2.4.4 Prestressing force

- (1) In a case where prestress is to be introduced into the structure, both the prestressing force immediately after the prestress is applied as well as the effective prestressing force after losses shall be considered in design and these values shall be determined according to the required performance.
- (2) If a statically indeterminate force is caused by prestress, it shall also be considered properly.

【Commentary】

- (1) The prestressing force immediately after the introduction of prestress should be calculated in consideration of the tensile force acting at the end of the prestressing steel, the elastic deformation of the concrete, the friction between prestressing steel and sheath, and the total amount of set at the anchorage.

The effective prestressing force should be obtained taking account of the prestressing force immediately after prestress introduction, concrete creep, concrete shrinkage, relaxation of prestressing steel, and the reinforcing bar restraint effect.

- (2) Redundant force generally arises because deformation of the structural member is restricted during prestressing, but this is avoidable if a proper arrangement of prestressing steel is developed. The possibility of redundant force must be taken into consideration when calculating the

distribution of stress over area.

If the timing of prestress introduction is staggered or if the degree of statical indeterminacy changes between the start and end of prestressing, the redundant force will vary as concrete creep increases. This point must be taken into consideration at the design stage.

The tensile force of the prestressing steel varies as a result of concrete creep, concrete shrinkage, and relaxation of the prestressing steel. Each cross section may have a different degree of variation. In general, the redundant force arising from the effective prestressing force may be calculated by multiplying the redundant force immediately after prestressing by the value obtained by averaging the tensile force effectiveness coefficient of each prestressing cable for each cross section over the whole of the structural member.

2.4.5 Live load

The live load shall consist of the moving load of vehicles, railway loading, and sidewalk loading (including crowd loading). It shall be determined according to the required performance by considering the load variations.

【 Commentary 】

The characteristic value of live load may be determined by referring the design standards such as the highway bridge specifications [Japan Road Association (2002a)] or the railway structure specifications [Railway Technical Research Institute (2000)], where the nominal value based on the legal authority is adopted. When designing a structure for a highway where restrictions may be placed on vehicles whose total weight or axle weight exceeds an a priori specified value, the specified value may be reduced if necessary. Also available is a method of determining the characteristic value of live load using computer simulation results, where traffic flow is modeled based on research into actual live load conditions [Fujiwara, et al (1988) and (1989)], as long as the characteristic value can be estimated, for example, in the case that the load-carrying capacity of an existing highway bridge is verified. However, loading methods in which the live load is a function of the number of lanes, as adopted in foreign standards such as [BS5400 (1978)], [OHBC (1983)], and [AASHTO (1996)], are more suitable than those where the live load is given according to the effective road width regardless of the number of lanes such as the "L load" specified in [JHA (2002a)].

When verifying fatigue resistance, all of the variable actions acting on a structure over the design working life must be considered and they must be determined taking account of an appropriate action value and the corresponding equivalent repetition value. In verifying fatigue resistance for a highway bridge, reference [JHA (2002c)] may be used.

2.4.6 Impact load

The stress imposed by the live load shall be incremented to account for impact effects. The dynamic influence of vehicles moving over the structure shall be considered as one kind of impact. The value of the impact load shall be determined according to the required performance in consideration of the structure's span, design characteristics, etc.

【 Commentary 】

The characteristic value of the impact load may be determined based on relevant standards, such as [JHA (2002a)] in the case of a highway bridge design or [RTRI (2000)] in the case of a railway bridge, that specify a standard value. In the case of highway bridges, for example, the impact load is modeled by replacing its dynamic effect with a static load obtained by multiplying the live load by an impact coefficient. On the other hand, in the case of railway bridges, impact load is determined taking

account of the maximum train speed, the axle arrangement, the number of cars or wagons, the span of the structural member, any non-linear behavior, the fundamental natural frequency, the damping constant, the kind of response value required, the track and vehicle maintenance level, etc. using an appropriate numerical analysis method such as dynamic response analysis.

2.4.7 Flowing water pressure

- (1) The value of flowing water pressure acting on a structure shall be determined according to the required performance in consideration of the type of structure and the shape of the structural members.
- (2) When designing structures on which flowing water may act, the dynamic influence of the flow water shall be taken into consideration.

【Commentary】

- (1) The characteristic value of flowing water pressure, p_w , can be defined by Eq.(C2.4.1).

$$p_w = \frac{1}{2} \rho C_v A v^2 \quad (\text{C2.4.1})$$

where , p_w : characteristic value of flowing water pressure
 C_v : coefficient of resistance depending on the cross-sectional shape of the structure
 ρ : density of water , 1000 kg/m³
 v : flow velocity (m/s) determined in correspondence with the relevant limit state
 A : projected area of structure in direction of flow(m²)

The value of coefficient of resistance (C_v) can be set referring to [JSCE (2002a)], [JHA (2002a)], and [RTRI (2004)].

- (2) In large sluices, such as a long sluice across a wide river or a Tainter gate used for the emergency release of water from a dam, it has been reported that vibrations can be caused during discharge. If such a phenomenon might be expected, the dynamic effect of the flowing water must be considered.

2.4.8 Hydrostatic pressure

The value of hydrostatic pressure shall be determined according to the required performance by properly taking into consideration fluctuations in water level and the size of the structure.

【Commentary】

The characteristic value of hydrostatic pressure can be calculated using Eq.(C2.4.2). However, if the hydraulic pressure acting on the below-ground part of the structure does not have a triangular distribution as a result of the particular ground conditions, the this value may be reduced to a level estimated from evidence such as field measurements of pore water pressure, etc.

$$p_h = w_0 h \quad (\text{C2.4.2})$$

where , p_h : characteristic value of hydrostatic pressure
 w_0 : unit weight of water (kN/m³)
 h : depth below surface of water (m)

Where a bridge abutment is planned for a location where water level fluctuations are particularly large, a difference in water level may arise between the upstream and downstream sides of the abutment. In such cases, the residual water pressure resulting from the difference in water level must be considered.

2.4.9 Buoyancy or uplift

- (1) The value of buoyancy or uplift shall be determined according to the required performance by properly taking into consideration the pore water and fluctuations in water level.
- (2) Buoyancy or uplift shall be assumed to act in the vertical direction and the severest case of uplift shall be assumed.

【 Commentary 】

- (1) Buoyancy is the load caused by an upward hydrostatic pressure on the bottom of a structure as a result of pore water in the ground or between the ground and the structure. Uplift is the load caused by a water level difference between the upstream and downstream sides of a structure or by a temporary increase in water level around a structure caused by wind, waves, etc.
- (2) Reference [JRA (2002a)] gives example cases in which buoyancy and uplift should and should not be taken into consideration. Also provided in this reference is a methodology for considering the buoyancy or uplift expected to act on a structure according to water seepage over time and the placement conditions of the structure. For example, the application methodology where the buoyancy or uplift shall be determined on the safer side in the structural design and this action shall be considered in case of falling down and sliding and not considered in case of settlement when verifying the stability of a structure is explained.

2.4.10 Wind load

- (1) The value of wind load shall be determined according to the required performance by properly taking into consideration the wind characteristics of the construction site, the type of structure, the shape of structural members, etc.
- (2) Flexible structures or structural members, in particular, shall be designed in consideration of dynamic deformation or stress resulting from wind because they may be considerably influenced by wind vibration.

【 Commentary 】

- (1) The possible effects of wind on a structure are the static wind load, gust response, divergent vibration, vortex-excited vibration, etc. These wind effects must be evaluated appropriately at the design stage because they may result in deformation and/or vibration of a structure.

The characteristic value of wind load is to be determined by estimating the wind velocity for each relevant limit state in consideration of measured wind speed data, the design working life of the structure, and the return period of specific wind velocity levels. In general, wind velocity is calculated from the mean value of wind speed over a period of ten minutes at a height of ten meters from the ground or sea surface; this figure is modified for altitude, horizontal and vertical length of structure, effect of ground surface roughness, effects of surrounding topography and geographical features on intercept and convergence, effect of temporal and spatial fluctuations in wind speed, etc. The value of drag coefficient is determined according to the cross-sectional shape of the structural member.

The characteristic value, W , of wind load can be obtained using Eq.(C2.4.3).

$$W = \frac{1}{2} \rho C A v^2 G \quad (\text{C2.4.3})$$

where , W : characteristic value of wind load
 C : drag coefficient depending on cross-sectional shape of structural member
 ρ : density of air, taken as 1.23kg/m³

- v : design wind speed determined (m/s) for each limit state
 A : projected cross-sectional area of structural member (m²)
 G : gust response coefficient.

The handling of structural members on the windward and leeward with respect to determining projected cross-sectional area, A , and drag coefficient, C , is provided in [JSCE (2002a)], [JRA (2002a)], and [RTRI (2004)]. Further, a suitable increment ratio, known as the gust response, is introduced to take account of deformation and/or vibration caused by fluctuating drag when calculating the characteristic value of wind load in [JRA (2002a)] and [JRA (2005)]. The value of the gust response coefficient, G , depends on only the intensity of wind turbulence in the case of normal structures; it increases with decreasing altitude and with increasing ground surface roughness. A suitable value of gust response coefficient may be obtained by referring to [JRA (2002a)] and [JRA (2005)].

References [JSCE (2002a)], [JRA (2002a)], and [RTRI (2004)] also provide for the wind load acting on bridges with noise barriers, existing bridges in parallel, and under-structures. Also given is a loading method for wind load. It should be noted that the change in cross-sectional shape caused by accumulated snow can sometimes influence the behavior of a structure significantly.

- (2) Occasionally, a structure may suffer from amplitude-limited vibration caused by light-wind-induced vortexes (vortex-induced vibration) or from vibration of rapidly rising amplitude caused by aerodynamic forces resulting from the vibration itself at high wind speeds and excites the vibration of structure (divergent vibration). Dynamic wind effects arising from vortex-induced vibration, divergent vibration, etc. must be considered in the design of flexural bridges such as suspension and cable-stayed bridges and of low-rigidity members such as the hangars in an arch bridge.

The wind velocity at which vortex-induced vibration, divergent vibration, and so on will occur and the likely vibration amplitude must be estimated appropriately in consideration of characteristics of winds at the construction site and the structural characteristics of the designed structure. The structure can be judged as satisfying the performance requirements if the wind velocity at which such vibrations occur is considerably higher than the maximum wind expected during the design working life or if the resulting vibration does not critically affect the safety and serviceability of the structure. The determination of the characteristic value of dynamic wind load for medium- and short-span bridges may be according to reference [JRA (2005)], while that for long-span bridges may be carried out as in [HSBA (2001)].

Reference [JRA (2005)], which gives the specifications for short and medium-span bridges, is also recommended for its presentation of recent research results relating to the following areas:

- 1) design concepts, actual examples of vibration control countermeasures, application examples, and matters for attention with respect to wind-induced cable vibrations;
- 2) estimation formula for the dynamic response of steel bridges with few (mainly two) I-shaped plate girders, based on actual examples, from the viewpoint of reducing erection work and construction costs, where particular care is needed because, as the span of such bridges increases and the natural frequency for torsional vibration falls below that of steel box-girder bridges, torsional vortex-induced vibration can arise;
- 3) estimation formula for the structural damping of bridges with rubber bearings.

2.4.11 Snow load

In the design of structures that are constructed in areas that receive snowfall, the value of snow load shall be determined according to the required performance by taking into consideration the

snowfall characteristics and maintenance procedures.

【 Commentary 】

The depth of snow on a structure depends not only on its location but also on whether snow removal is carried out, the characteristic value of snow load should preferably be determined in consideration of local snowfall characteristics, maintenance procedures, and the design working life of the structure using actual records of snowfall.

There are two main categories of method for calculating the value of snow load. One assumes that vehicles continue to pass over the fully compacted snow, while the other takes account only of the snowfall because passage of vehicles becomes impossible. In the former, a value of 1 kN/m² for compacted snow up to 150 mm in thickness is specified in, for example, reference [JRA (2002a)]. In the latter case, the characteristic value of snow load is given by Eq.(C2.4.4) where the design unit weight of snow, (w_s), is determined referring [JRA (2002a)] or [RTRI (2004)].

$$SW = w_s z I \quad (C2.4.4)$$

where , SW : characteristic value of snow load
 w_s : design unit weight of snow (N/m³)
 z : design snowfall depth on surface(m)
 I : coefficient due to inclination of surface
 $I = 1 + (30 - \theta)/30$
 where , $I = 1.0$ for $\theta \leq 30^\circ$ and $I = 0$ for $\theta \geq 60^\circ$
 θ : inclination of surface subjected to snowfall ($^\circ$)

2.4.12 Braking force and acceleration force

Braking forces and acceleration forces act on a structure when vehicles and trains slow down or accelerate. The values of these forces are determined according to the required performance by properly taking into consideration the types of vehicles or trains and the characteristics of the structure.

【 Commentary 】

In the case of structures that carry trains, braking and acceleration forces must be considered in the design. Particularly careful investigation of these forces is necessary in the case of extremely light structures that carry trains. Specifications such as [JRA (2002a)] and [RTRI (2000)], where standard values for these two forces are prescribed, should preferably be referred to in the design of highway bridges and railway bridges.

2.4.13 Centrifugal force

A structure carrying curved tracks shall be designed to withstand centrifugal force. The value of centrifugal force shall be determined according to the required performance by properly taking into consideration the type of train and the characteristics of the structure.

【 Commentary 】

Specifications such as [JRA (2002a)] and [RTRI (2000)] give standard values for centrifugal force which should be used in the design of highway bridges or combined railway-highway bridges.

2.4.14 Longitudinal load imposed by long welded rail

Where long welded rails are laid on a railway bridge, the mutual force resulting from differences between the behavior of the rails and the bridge under temperature changes shall be treated as a longitudinal load imposed by the long rails. The value of this longitudinal load shall be determined according to the required performance by considering the type of bridge, its length, the track type, the arrangement of bearings, etc.

【 Commentary 】

Where a railway bridge carries long continuously welded rails, a force arises from the differential expansion of rails and the bridge under temperature changes. This force acts on both rail and bridge through the rail fastenings. In general, this force is treated as a longitudinal load in the design of railway bridges. The characteristic value of longitudinal load imposed by continuously welded rail may be determined with reference to the specifications for railway bridges [RTRI (2000)], where values are provided.

2.4.15 Lateral train load and transverse wheel thrust

A train crossing a bridge imposes a lateral load while the wheels cause a transverse thrust. The values of these forces shall be determined properly according to the required performance.

【 Commentary 】

The lateral train load is the transverse force resulting from oscillations of railway vehicles, such as yawing, etc. Transverse wheel thrust is the force produced by the wheels if a railway vehicle car enters a section of track with an angle of incidence. The characteristic values of these two loads may be determined by reference to the specifications for railway bridges [RTRI (2000)], where static values determined based on available experimental evidence are provided. In theory, however, the dynamic effects of these two loads should be taken into account.

2.4.16 Wave pressure

The value of wave pressure shall be properly determined according to the required performance by considering the type of structure, its shape, the water depth, and the wave characteristics.

【 Commentary 】

The characteristics of wave pressure depend on the type of structure they are acting on. For example, the wave pressure is different on a continuous vertical wall structure, such as a breakwater, than on an isolated vertical structure, such as a bridge pier. The characteristics also depend on water depth and the wave properties. These factors must be properly considered at the design stage.

2.4.17 Erection-related force

Structures are generally designed in consideration of the structural system in place at completion, but this may differ from the system of load support during erection. The forces arising during erection shall be properly taken into consideration according to structural conditions during erection and erection procedure used.

【 Commentary 】

Sufficient safety must be ensured at all erection steps used during construction. Structures are

generally designed in consideration of the structural system in place at completion. However, this may differ from the system of load support and the loading conditions during erection, and the direction of loading may even be reversed in certain cases. Accordingly, in the design of structures as already described, it is necessary to verify and confirm structural safety for each erection step.

The vertical force (self weight of structural members), wind load, effect of earthquake, snow load, effect of temperature changes, horizontal force, impulsive load, frictional force, disproportional load, expected special load, and so on are among the erection-related forces that must be considered. The actual selection of loads to be considered as erection-related forces should preferably be made in consideration of the type of structure, the erection procedure, the season during which erection takes place, the erection period, etc. Earth pressure, wave pressure, buoyancy, collision forces, and other special loads should be considered as required.

2.4.18 Collision force

A collision force might be imposed by a user of the structure, as in the case of a vehicle collision, by a third party as in the case of a ship impact, or through a natural phenomenon such as impact by driftwood, etc. The anticipated value of the collision force shall be determined according to the required performance in consideration of the location of the structure.

【Commentary】

Collision forces may be imposed on the structure by vehicles, ships and other water craft, airplanes, driftwood, falling rocks, and others. Whether each type of collision force is considered in the design and the selection of a suitable value should be determined in consideration of the location of the structure and the likelihood of each type of collision. If the collision force is expected to be considerably large, consideration might be given to the construction of a secondary protective structure.

There are two methods of determining the characteristic value of collision force. One is to define the velocity, mass, size, and incidence angle of the body that is in collision with the structure, taking account of any special modes at the time of collision. The other is to replace the dynamic collision energy with a static force based on consideration of the mechanical equivalence property. Characteristic values of collision forces acting against the guard rail and floor slab may be determined with reference to the specifications [JRA (2002a)] and [JRA (2004)].

2.4.19 Concrete shrinkage

- (1) The characteristic value of concrete shrinkage shall be determined in consideration of the materials used, environmental conditions, the size of structural members, etc.
- (2) In the design of statically indeterminate structures such as rigid frames and arches, concrete shrinkage may have a uniform effect on the cross section of the structure.

【Commentary】

- (1) Total concrete shrinkage comprises drying shrinkage, self shrinkage, and carbonation shrinkage. It is influenced by the temperature and humidity to which the structure is exposed, the shape and size of structural members, the concrete mix proportion, the properties of the aggregates, the type of cement, the degree of concrete compaction, the concrete curing conditions, and various other factors. Therefore, the value of shrinkage strain used in the verification must be determined in consideration of these factors.

Where the total shrinkage strain and the rate of shrinkage progress in normal concrete with a compression strength of less than 55 N/mm^2 (or 70 N/mm^2 in the case of high-strength concrete

with a low water-cement ratio) are obtained from the surrounding temperature and member size, which are the factors that have a strong effect on shrinkage, reference [JSCE (2002a)] may be used.

The actual concrete mix proportion is generally not yet known at the design stage, so the values of shrinkage strain for normal concrete and lightweight aggregate concrete given in Table-commentary 2.4.2 may be applied in general.

Table C2.4.2 Shrinkage strain of concrete ($\times 10^{-6}$)

environmental conditions	age of concrete*				
	up to 3 days	4×7 days	28 days	3 months	1 year
indoor	400	350	230	200	120
outdoor	730	620	380	260	130

* age from start of drying as considered in design

- (2) The value of concrete shrinkage strain used when calculating the redundant force based on elastic theory may be taken as 150×10^{-6} in general, although the effect of concrete creep should be considered.

2.4.20 Effect of concrete creep

- (1) The characteristic value of concrete creep shall be determined in consideration of the materials used, environmental conditions, structural member size, concrete age at application of stress, etc.
- (2) In the design of statically indeterminate structures such as rigid frames and arches, concrete creep may have a uniform effect on the cross section of the structure.

【Commentary】

- (1) The creep strain of concrete may be calculated using Eq.(C2.4.5) under the assumption that it is proportional to the elastic strain by the stress arising.

$$\varepsilon'_{cc} = \frac{\phi \sigma'_{ct}}{E_{ct}} \quad (2.4.5)$$

where , ε'_{cc} : compressive creep strain of concrete
 ϕ : creep coefficient
 σ'_{ct} : compressive stress arising
 E_{ct} : Young's modulus at age of loading

However, the application of Equation (commentary 2.4.5) is limited to cases where the compressive stress of the concrete is no more than about 40% of its compressive strength. Where this is not so, it is not suitable to consider creep strain as proportional to the elastic strain caused by the stress arising. The creep coefficient depends on the temperature and humidity to which the structure is exposed, the shape and size of structural members, the concrete mix proportion, the age of the concrete at loading, the properties of the aggregates, the type of cement, the concrete compaction, the concrete curing conditions, and various other factors. Therefore, the design value of creep coefficient should be determined by referring to experimental results, field measurements of existing structures, etc. In a case where the creep coefficient of normal concrete with a compression strength of up to 55 N/mm^2 (70 N/mm^2 in the case of high-strength concrete with a low water-cement ratio) is to be obtained without experiment, reference [JSCE (2002a)] may be used.

The values of creep coefficient for prestressed concrete shown in Table C2.4.3 or Table C2.4.4

may be applied in general. If the creep strain is obtained using Table C2.4.3 or Table C2.4.4 and Eq.(C2.4.5), the value of ϵ_{ct} should be that at the age of loading.

Table C2.4.3 Creep coefficient for normal concrete

environmental conditions	age of concrete at prestressing or loading				
	4×7 days	14 days	28 days	3 months	1 year
indoor	2.7	1.7	1.5	1.3	1.1
outdoor	2.4	1.7	1.5	1.3	1.1

Table C2.4.4 Creep coefficient for lightweight aggregate concrete

environmental conditions	age of concrete at prestressing or loading				
	4×7 days	14 days	28 days	3 months	1 year
indoor	2.0	1.3	1.1	1.0	0.8
outdoor	1.8	1.3	1.1	1.0	0.8

2.4.21 Effect of temperature changes

- (1) The effect of temperature changes shall be determined according to the required performance by taking into consideration the type of structure, environmental conditions, the size of structural members, etc.
- (2) The characteristic value of temperature change shall be determined as a rise and fall in temperature from an a priori specified temperature. In the design of statically indeterminate structures, temperature change may have a uniform effect on the cross section of the structure.
- (3) In the case of a structure in which the temperature difference between structural members or between portions of the structure is not negligible, such differences shall be taken into account.
- (4) In order to ensure a safe-side design, the characteristic value of temperature change when calculating the structure's stress resultant shall preferably be different from that used in determining the deformation of the structure.

【 Commentary 】

- (1) Changes in temperature cause structural deformations such as shrinkage, expansion, warping, etc. Because the total amount of deformation depends on how much the temperature changes, a reference temperature and temperature variation range should be determined in consideration of the type of structure, environmental conditions at the construction site, the properties of the materials used, the size of members, and so on. Design values relating to the temperature variation range and temperature distribution may be determined from the actual situation if good estimates are available for these two values. These values depend on the many factors noted above as well as on which actions are considered as load combinations.
- (2) In the design of statically indeterminate structures such as rigid frames and arches, it may be assumed that temperature changes occur uniformly over the cross section of the structure. The design value of reference temperature should preferably be +20 in general or +10 in cold regions. The design value of temperature variation range, under the assumption that the variations occur uniformly over the whole of the structure, may be determined as follows:
 - 1) the range of temperature variations for steel structures is from -10 to +50, or from -30 to +50 in cold regions;
 - 2) the range of temperature variations for concrete structures must be determined in consideration of the difference between the reference temperature and the average air temperature

- at the construction site. In general, the value should be 15 while it should be ± 10 if the minimal size of the cross section is greater than or equal to 700 [mm] because in this case the effect of temperature variations is not serious;
- 3) the effect of temperature variations for a structure in the water or under the ground may be negligible.
- (3) If temperature changes give rise to variations in temperature, and resulting differential expansion or shrinkage, between two structural members or between different two parts of one member, the effect of this must be considered. The design value of temperature differential may be determined as follows:
- 1) the relative temperature differential for steel structures is 15 ;
 - 2) the relative temperature differential between a concrete floor slab and a steel girder in the design of a steel girder bridge with a concrete floor slab is 10 , with the temperature distribution over each member assumed to be uniform;
 - 3) the relative temperature differential for concrete structures at the point of the maximal value of redundant force is 15 in the Chubu region of Japan (inland areas and the Hokuriku district) and in the northern part of the Tohoku district, while it is ± 12.5 in other districts. In this case, the minimal size of a hollow cross section, such as a box-shape section, should be determined without any deduction of the size of the portion completely shut down from the outside air; the relative temperature differential between the floor slab and other structural members is 5 and the temperature distribution in each is considered uniform;
 - 4) because the cracks caused by annual temperature changes open and close, the characteristic value of temperature change for estimating cracks in assessing durability may be reduced from the value specified in 3) above where the maximal redundant force is considered; in general, a 20% reduction is allowed;
 - 5) structures such as floor slabs subject to high temperatures, chimneys, and tanks storing liquids at high or low temperatures have large temperature differentials between surfaces. In such cases, the internal stress resulting from temperature changes must be taken into account because the assumption of uniform temperature change over the cross section is not realistic.
- (4) the range of temperature variation used to calculate movements of bearings and expansion joints in the design of bridge may in general be taken from Table C2.4.5.

Table C2.4.5 Range of temperature variation for the calculation of bearing and expansion joint movement in bridge design

type of bridge	temperature change	
	normal temperatures	cold regions
reinforced concrete bridge	-5 ~+35	-15 ~+35
prestressed concrete bridge		
steel bridge (deck bridge)	-10 ~+40	-20 ~+40
steel bridge (through bridge and steel plate deck bridge)	-10 ~+50	-20 ~+40

2.4.22 Effects of displacement of supports and differential settlement

- (1) Where displacement of a structure's supports and/or differential settlement is anticipated and if the effects of such movement on the structure might be significant, their effects shall be determined according to the required performance in consideration of the type of structure and subsoil conditions.

- (2) The characteristic values of displacement of a structure's supports and/or differential settlement shall be determined carefully as they may have a considerable effect on the size and shape of structural members.

【Commentary】

- (1) During the Kocjaeri earthquake in Turkey and the Cheche earthquake in Taiwan in 1999, bridge girders collapsed and a dam body failed after displacements of 5-10 meters occurred at faults. Where a fault is thought to be present under a designed structure, the probability of a displacement occurring during the design working life and its magnitude should preferably be estimated at the design stage. In the design of a bridge, however, it is very difficult to cope well with large fault displacements, so it is important to secure good redundancy in the road network, to establish an early recovery plan, and to develop earthquake-proofing techniques as well as to clarify the performance requirements.

2.4.23 Effect of earthquake

- (1) Earthquake motion and all actions resulting from earthquake motion shall be considered in the seismic design of a structure.
- (2) In taking account of the direction of earthquake motion, it is preferable that two perpendicular directions on the horizontal plane be considered not independently rather than simultaneously. If necessary, earthquake motion in the vertical direction shall be considered according to the dynamic characteristics of the structure.
- (3) Two classes of earthquake motion shall be used in verification, as follows.
- ① Level 1 earthquake motion that has a relatively high probability of occurring during the working life of the structure.
 - ② Level 2 earthquake motion that is strong and has a relatively low probability of occurring during the working life of the structure.
- (4) The worst-case effect of earthquake motion on the structure shall be determined by considering seismicity around the site of construction, characteristics of the hypocenter and propagation of earthquake motion, amplification characteristics depending on subsoil conditions at the site, etc.
- (5) Generally, a time-history acceleration wave of earthquake motion shall be used for verification.

【Commentary】

- (1) The effects of earthquake on a structure are generally considered to be the following:
- ① inertial forces caused by structural masses and attached masses
 - ② dynamic interaction between structure and soil
 - ③ hydrodynamic pressure during earthquake
 - ④ earthquake-induced ground deformation, such as liquefaction of soil and resulting ground flows

In considering the effects of earthquake at the design stage, the type of structure and its loading conditions, the surrounding environment, and other factors determine which of these effects should be taken into account.

Both the mass of the structure itself and the mass of any attached structures should be considered as contributing to the inertial force under earthquake motion. In general, the masses of permanent actions and subsidiary actions may be considered under the assumption that the mass of attachment bodies causes the inertia force along with the earthquake.

Dynamic interactions between structure and soil arise because of a relative difference in dynamic response characteristics between the two. These dynamic interactions need to be taken into account in the case of abutments, retaining walls, underground structures, foundation structures such as piles and caissons, and similar.

In the design of structures that hold liquids, such as storage tanks, and those that stand in water, such as bridge piers, the hydrodynamic pressures arising from both the added mass of the stored liquid and its vibration must be taken into account, as these act on a structure during earthquake. Countermeasures against soil liquefaction are the basis of the seismic design process of a structure. However, the effect of soil liquefaction on the seismic resistance of a structure must also be fully considered at the design stage if countermeasures are expected to be technically difficult or particularly uneconomical. Where the ground surface is sloping or if the pressure on the structure is always unsymmetrical, then ground flows caused by liquefaction must be considered as they might occur during an earthquake.

- (2) Horizontal earthquake motion alone may, in general, be taken into account in verifying seismic performance because it is the dominant earthquake effect on a structure. Although horizontal earthquake motion can act on the structure in any random direction, verification may be carried out in two independent orthogonal directions. However, in the design of curved-in-plane bridges, structures in which torsion arises, and columns on which largely eccentric axial forces act, the influence of earthquake motion from multiple directions should ideally be considered, as the structure might show multi-axial response even for earthquake motion from one direction.

Verification against vertical earthquake motion must be carried out if the effect of vertical motion on the seismic resistance of the structure, which depends on the type, shape, and rigidity distribution of the structure, is not negligible.

- (3) Two classes of earthquake motion must be used to verify seismic performance, preferably considering the characteristics of earthquake motions, as follows:

Level 1 earthquake motion, which has a relatively high probability of occurring during the working life of the structure.

Level 2 earthquake motion, which is a strong motion with a relatively low probability of occurring during the working life of the structure [JSCE Research Subcommittee for Level 2 earthquake motion (2000)].

The intensity of each of these motions may be determined by specifying a return period based on the working life of the structure. In references [JSCE (2001)] and [JSCE (2002a)], the return period for Level 1 earthquake motion is specified as 50 years. On the other hand, the return periods of Level 2 earthquake motion, defined as Type I or Type II as below, may be specified as 100 years and 1000 years, respectively. The latter is specified in order to consider extremely strong earthquakes.

- ① Type I earthquake motion: earthquake motion caused by a large-scale interplate earthquake just offshore
 - ② Type II earthquake motion: earthquake motion caused by the shifting of an active fault in the epicentral area or nearby
- (4) The actual earthquake motion used for verification should take into account the seismicity in the vicinity of the construction site, the characteristics of the hypocenter, the propagation of the earthquake motion, the amplification characteristics, etc. However, it is very difficult to estimate all of these factors accurately and in fact some of them are at present still very uncertain, so earthquake motion for verification may in general be established by taking into account measured earthquake motions and the failure mechanism of the earth's crust in the epicentral area.
- (5) Generally, a time-history acceleration wave should be used to represent earthquake motion in the verification, because the dynamic response of a structure to Level 2 earthquake motion is

analyzed using nonlinear time-history analysis. The effects of earthquake on the structure must be expressed in suitable form according to the analysis method adopted, such as the static structural analysis method, the response spectrum method, etc.

2.4.24 Effect of airborne salinity

If required performance is determined in consideration of airborne salinity, the worst-case effect over the structure's working life shall be assumed by considering the site location, the materials used, etc.

【Commentary】

The amount of salt in the air determines the selection of steel products and rust protection methods as well as the cover thickness for a floor slab and felloe guard concrete and the method of protecting reinforcing bars from rust. Airborne salinity should preferably be determined from field measurements at the construction site because it depends on region, topography, distance from the shore, etc. Reference [PWRI, SPC and JBCA (1993)] may be used to obtain a value if field measurements are impossible.

2.4.25 Effect of exhaust gases

In designing a structure located where traffic jams are common, the effect of exhaust gases shall be considered by taking into account traffic flow volumes and transportation system management.

【Commentary】

Concrete structures such as those that form the Metropolitan Expressway in Tokyo are exposed to severe environmental conditions because of the presence of exhaust gases. Test surveys and chemical testing on concrete bridge components exposed to exhaust gases for more than 30 years have shown that the concrete neutralization depth relates to the amount of carbon adhered to the surface. It has been also been revealed that nitrogen and sulfur oxides contained in exhaust gases further promote concrete deterioration. This poses a particular problem for poured concrete expressway walls, for which it is difficult to guarantee compaction quality during construction because of their large height to breadth ratio.

In designing road structures for locations where traffic jams are common, the cover thickness of concrete members expected to suffer deterioration because of exhaust gases should ideally be ensured by taking into account the design working life and maintenance procedures.

2.4.26 Effect of carbon dioxide concentration

If necessary, the effect of carbon dioxide (CO₂) concentration shall be considered as it might affect the neutralization of concrete.

【Commentary】

It is known that carbon dioxide (CO₂) influences the neutralization of a concrete structure. The progress of neutralization has been generally assumed, on the basis of experiments and observations, to follow the \sqrt{t} law with elapsed time (t); that is, a parabolic law. Accelerated tests with a high set value of CO₂ concentration have also shown adherence to this parabolic law. What this means is that, if CO₂ diffusion into concrete follows Fick's first law, the neutralization depth remains proportional to the square root of elapsed time and is also proportional to the square root of the difference in CO₂ density between the surface and the interior of the concrete.

Since the latter half of the 20th century, the CO₂ concentration of the air has tended to increase

annually, although seasonal changes are also observed. Further, it is expected that the synergistic effect of this trend and air temperature rises driven by global warming might result in accelerating CO₂ concentrations in the latter half of the 21st century. The value of carbon dioxide concentration used to estimate and evaluate durability should be determined by considering recent research that shows the neutralization rate of concrete increasing step-wise if the CO₂ concentration does so.

According to the current specifications [JSCE (2002b)], no concrete neutralization problems are expected to occur for 100 years or more if concrete is suitably mixed with normal portland cement and a water-to-cement ratio of less than 50% as long as the cover thickness is greater than 30mm. However, this example assumes current CO₂ concentrations.

2.4.27 Effect of acid concentration

The worst-case effect of acid concentration on the structure over its design working life shall be determined by considering the site location, materials used, etc.

【Commentary】

Acid-induced chemical corrosion is rarely a problem for steel structures in a normal environment. However, the effect of acid concentration should be considered as required if field measurements of acid concentration indicate a need, particularly if the structure is situated in an unusual environment such as in a hot spring area or in the drainage basin of an acid river.

2.4.28 Effect of drying and wetting

The effect of repeated drying and wetting shall be considered in the case that a structure is subject to extremely frequent dry-wet cycles, since cracks leading to deterioration of concrete members may result.

【Commentary】

According to the literature [Kato, et al. (1987)], water absorption and dehydration in the range of 6% and expansion and contraction of $\pm 300 \times 10^{-6}$ can result from repeated drying and wetting of a concrete member. Therefore, the effect of repeated drying and wetting should be considered in cases where a structure is subject to extremely frequent dry-wet cycles. If a waterproofing method such as coating with a waterproof agent is to be used, its effectiveness should be considered after adequate discussion based on experimental data.

2.4.29 Effect of sunshine

In the case that a steel structure has a required performance relating to painting for which the effect of sunlight is considered, the worst-case effect of sunshine over the design working life shall be determined by considering the site location, materials used, etc.

【Commentary】

The durability of a steel structure may be reduced because of a phenomena by which the pigment included in the paint film discolors under ultraviolet radiation from the sun. The surface of the paint film is resolved into a powder (through a process known as the "chalking phenomenon"). The performance requirements for the paint film should be satisfied, taking account of the weather resistance of the structure over its design working life.

2.4.30 Effect of freezing

In a case where repeated freezing and thawing might cause severe cracking in concrete members, the effect of freezing shall be considered properly.

【Commentary】

The factors determining concrete's susceptibility to freezing damage are divided into three categories: factors relating to the environment, factors relating to the supply of water, and factors relating to the quality of the concrete. The first category corresponds to environmental conditions, such as meteorological effects like the minimum temperature and the amount of sunshine received by the structure. The second corresponds to rainfall, snowfall, and splashing, where freezing might occur if water is supplied to the surface of a concrete member. The third corresponds to the type and quality of materials used, the quality of the concrete (depending on its mix proportion), and the construction quality, including placement, compaction, curing method, curing period, etc.

Countermeasures against freezing should preferably be applied after considering these three types of factors.

2.4.31 Effect of fire

In a case where there is a possibility of the structure being exposed to high temperatures such as in a fire, their effects shall be considered properly.

【Commentary】

In a case where there is a possibility of the structure being exposed to high temperatures, such as in a fire, their effects must be properly considered according to both the level of damage caused and the performance required of the structure after the disaster. In other words, it must be confirmed whether the material properties of the steel and concrete members will change under the anticipated high temperatures or not, and the possibility of continuing to use the members must be judged. In the specifications for building structures, it is prescribed that the upper limit of elevated temperature is 350 and that, after cooling, concrete which has experienced a temperature up to 500 should remain usable. Reference [JCI (2002)] may also be consulted.

2.5 Action Factors

- (1) An action factor is used to take into account any unfavorable deviation of the statistical characteristic value of an action, uncertainties relating to action modeling, changes in action characteristics over a given reference period, influence of action characteristics on the relevant limit state of structure, variations in environmental action, and so on. The actual design value of each action shall be obtained by multiplying the action value as defined in 2.4 by its corresponding action factor.
- (2) Where combinations of actions are taken into consideration, the action factors described in (1) above shall be modified by a reduction factor in consideration of the probability of the simultaneous occurrence of multiple actions according to the judgment of the responsible chief engineer.

【Commentary】

- (1) The action factors that might be introduced when actions specified in Article 2.4 are used in the

design of steel and composite structures are given here. The following definitions are assumed:

- "Unfavorable deviation of the statistical characteristic value of an action" means there is a possibility that an extremely serious outcome (negative convenience) might arise if larger (or smaller) actions than expected act on the steel or composite structure, leading to the structure reaching its limit state.
- "Uncertainties relating to calculation of action value" corresponds to inadequacy in the statistical data used in the calculation of the statistical characteristic value of the relevant action.
- "Changes in action characteristics over a given reference period" means an expectation of changes in the characteristics of the relevant action itself. An example would be the expectation that average air temperatures will rise as a result of global warming.
- "Influence of action characteristics on the relevant limit state of structure" means there is a possibility that, for instance, an impulsive action might cause a sudden failure such as a brittle fracture.
- "Variations in environmental action" means the expectation of changes in the corrosion environment surrounding a steel member as a function of time elapsed, for example.

If an action factor is adopted in consideration of the factor(s) described above, the engineer in charge of design is expected, in principle, to determine the value of the action factor. Here, the values of action factors corresponding to "unfavorable deviation of the statistical characteristic value of an action" and "influence of action characteristics on the relevant limit state of structure" should be determined subjectively based on the experience and instincts of the engineer in charge. The value of an action factor relating to "uncertainties relating to calculation of action value" should be determined by applying statistics. The values of action factors related to "changes in action characteristics over a given reference period" and "variations in environmental action" should be determined through the application of both the experience and instincts of the engineer in charge and statistics.

Table C2.5.1 Load combination factors and load modifying factors proposed by [JRA (1986)]

combination of loads	load modification factor															
	P				S				PP				PA			
	D	L+I		HP	U	W	T	EQ	SW1	SW2	GD	SD	WP	CF	BK	CO
T-20		L-20														
P+PP	1.0	3.1	1.7	1.0	1.0	–	–	–	1.0	1.0	1.0	1.0	1.0	1.0	–	–
P+PP+T	1.0	1.6	0.9	1.0	1.0	–	1.0	–	1.0	–	1.0	1.0	1.0	1.0	–	–
P+PP+W	1.0	–	–	1.0	1.0	1.0	–	–	1.0	–	1.0	1.0	1.0	1.0	–	–
P+PP+EQ	1.0	–	–	–	–	–	–	1.0	–	–	–	–	–	–	–	–
P+PP+CO	1.0	1.6	0.9	1.0	1.0	–	–	–	1.0	–	1.0	1.0	1.0	1.0	–	1.0
ER	to be considered according to erection conditions															

–: means the load is not included in the load combination

(Load modification factors relating to PS, CR, SH, and E have been omitted because they are as yet undecided.)

P	: primary load	W	: wind load	CF	: centrifugal force
S	: subsidiary load	T	: effect of temperature changes	CO	: collision force
PP	: partial primary load	EQ	: effect of earthquake	ER	: erection-related force
PA	: partial subsidiary load	SW1	: snow load considering compacted snow	PS	: prestressing force
D	: dead load	SW2	: snow load considering only snowfall depth	CR	: effect of concrete creep
L	: live load	GD	: effect of ground displacement	SH	: effect of concrete shrinkage
I	: impact	SD	: effect of support displacement	E	: earth pressure
HP	: hydrostatic pressure	WP	: wave pressure	BK	: braking force including acceleration force
U	: buoyancy or uplift				

Values specified in other standards may, as explained below, be adopted if the determination of a suitable value is difficult. It should be noted, however, that there is also an opinion that there is no need to adopt action factors in the design of steel and composite structures judging from past design achievements and from the way they are specified in the current standards [JSCE

Table C2.5.2 Combinations of actions and action factors specified in [RTRI (2000)]

(a) steel bridge (steel girder)

limit state	combination of action and action factor	performance item prescribed in this Design volume
verification of ultimate limit state	$\cdot 1.0D + 1.1L + 1.1I + 1.1C + \{L_R\} + \{T\}$ $\cdot 1.0D + 1.1L + 1.1I + 1.1C + \{L_R\} + \{L_F\} + \{W\}$ $\cdot 1.0D + 1.1L + \{L_R\} + \{B\} + \{W\}$ $\cdot \{L_R\} + 1.1B$ or $1.1L_R + \{B\}$ $\cdot 1.1L_F + \{W\}$ $\cdot 1.1B + \{W\}$	verification of safety (load-carrying capacity)
	$\cdot 1.0D + 1.1L^{*2} + 1.1C^{*2} + 1.0W$ $\cdot 1.0D + 1.2W$ $\cdot D + L + C + E_Q$	verification of safety (load-carrying capacity)
verification of serviceability limit state	$\cdot [D] + L + [C] \cdots$ deflection by train load	verification of serviceability (train operating performance)
verification of fatigue limit state	$\cdot 1.0D + 1.1L + 1.1I + 1.1C \cdots$ verification of fatigue limit $\cdot D + L + I + C \cdots$ verification considering repetition number	verification of durability (fatigue resistance)

(b) composite girder

limit state	combination of action and action factors	performance item prescribed in this Design volume
verification of ultimate limit state	$\cdot 1.1^{*1}D_1 + 1.0D_2 + 1.1L + 1.1I + 1.1C + 1.0S_H + 1.0C_R + \{L_R\} + \{T\}$ $\cdot 1.1^{*1}D_1 + 1.0D_2 + 1.1L + 1.0S_H + 1.0C_R + \{L_R\} + \{B\} + \{T\}$	verification of safety (load-carrying capacity)
	$\cdot 1.1^{*1}D_1 + 1.0D_2 + 1.1L^{*2} + 1.1C^{*2} + 1.0W$ $\cdot 1.1^{*1}D_1 + 1.0D_2 + 1.2W$ $\cdot D_1 + D_2 + L + C + E_Q$	
verification of serviceability limit state	$\cdot [D] + L + [C] \cdots$ deflection under train load	verification of serviceability (train operating performance)
verification of fatigue limit state	$\cdot 1.1^{*1}D_1 + 1.0D_2 + 1.1L + 1.1I + 1.1C \cdots$ verification of fatigue limit $\cdot D_1 + D_2 + L + I + C \cdots$ verification considering repetition number	verification of durability (fatigue resistance)

\cdot Actions in { } are subsidiary variable actions.

\cdot Actions in [] are combined with other actions as required.

\cdot *1 Action factor 1.0 is used for the dead load of a concrete floor slab and action factor 1.1 is used for a steel girder.

\cdot *2 When the influence of empty train vehicles is greater, 1.0 is used.

Action symbols used in the table are as follows:

D : Dead load	D_1 : Fixed dead load	D_2 : Additional dead load
L : Train load	I : Impact	C : Centrifugal load
L_R : Longitudinal load imposed by long welded rail	L_F : Lateral train load and transverse wheel thrust	B : Braking force and acceleration force
W : Wind load	T : Effect of temperature changes	C_R : effect of concrete creep
S_H : effect of concrete shrinkage	E_Q : earth pressure	

(1998)].

As an example of the values adopted in other standards, the following are given in Common Principles in Limit State Design Methods for Steel and Concrete Structures [SCCSDSS (1992)]: 1.0~1.2 for permanent actions (1.0~0.8 in cases where a smaller value is critical) 1.1~11.2 for primary variable actions

Regarding action factors for use in the design of highway bridges, [JRA (1986)] proposes the values shown in Table C2.5.1, which incorporate the concept of load combinations. The values given in this table may be used in the design of highway bridges or similar steel and composite structures.

Similarly, action factors for use in the design of railway bridges can be taken from Table C2.5.2, as specified in the Standard Specifications for Railway Structures and its commentary (Steel and Composite Structures) [RTRI (2000)]. Here, detailed values are listed according to

the limit state considered at the design stage and to load combinations. The third column in Table C2.5.2 indicates the applicable performance items prescribed in this Design volume.

- (2) With regard to combinations of actions, a coefficient that increases the allowable stress is introduced in the current Standard Specifications for Highway Bridges [JRA (2002)], for example. In these specifications, the probability that multiple actions will occur simultaneously is taken into account by reducing the action level against combinations in which frequently occurring action(s) coincide with rarely occurring action(s). Combinations of actions that are extremely rare are disregarded. Table C2.5.3 lists the prescribed reduction factors for various combinations of actions. These reduction factors correspond to the inverse of the coefficient that increases allowable stress in the Standard Specifications for Highway Bridges, which were obtained from past investigations [Sugiyama, et al. (1990)].

Table C2.5.3 Reduction factors for combinations of actions

load combination	reduction factor
1. primary load(P)+particular primary load(PP)	1.00
2. primary load(P)+particular primary load(PP)+ effect of temperature changes(T)	0.90
3. primary load(P)+particular primary load(PP)+wind load(W)	0.80
4. primary load(P)+particular primary load(PP)+ effect of temperature changes(T)+wind load(W)	0.75
5. primary load(P)+particular primary load(PP)+ braking force(BK)	0.80
6. primary load(P)+particular primary load(PP)+collision force(CO)	
for steel member	0.60
for reinforced concrete member	0.70
7. primary load(P) except live load and impact + effect of earthquake(EQ)	0.70
8. wind load(W) only	0.85
9. braking force (BK) only	0.85
10. erection-related force(ER)	0.80

It is necessary to classify P, PP, and other loads described in the Standard Specifications for Highway Bridges into the categories permanent action, primary variable action, and subsidiary variable action as defined in this Design volume.

Action factors proposed in other standards for the load combinations shown in Table C2.5.1 and 2.5.2 may be used if their application is judged to be preferable.

As for action combinations that include multiple variable actions acting on the designed structure or structural member, Turkstra's method should be adopted; the value of the primary variable action is equal to the characteristic value given in Article 2.4 while values of the other variable actions are the expected design working life maximum (or minimum) value distributions and then these values are then summed up [Turkstra, et al. (1980)].

With the capabilities of personal computers advancing so rapidly in recent times, it is now possible to adopt the Monte Carlo simulation method if sufficient information has been collected to determine the probability distributions of occurrence frequency (or the interval between two consecutive occurrences), duration, and intensity of the variable action and its fluctuations. If such a simulation method is adopted, the maximal value of combined load or the 5-10

It is necessary to classify P, PP, and other loads described in the Standard Specifications for Highway Bridges into the categories permanent action, primary variable action, and subsidiary variable action as defined in this Design volume.

References in Chapter 2

- Sugiyama et al.(1985) : Determination of distribution model and characteristic value from statistical data, Journal of Structural Engineering, Vol.31A, pp.287-300.
- Japan Road Association - Bridge committee - Subcommittee for limit state design method (1986,1989) :First report by subcommittee for limit state design method - working group for loads and second report by

- Subcommittee for limit state design method - working group for loads.
- Ishii, et al.(1987) : Vibration of long span water sluice caused by fluid motion, Proc. of JSME-Part B ,53-495 , pp.3267-3273 .
- Kato, et al.(1987) : Deterioration of durability of concrete member caused by drying and wetting and countermeasures, Journal of JSCE Annual meeting No. 24, V-216, pp.470-471 .
- Fujiwara, et al.(1988) : Estimation of design live load in limit state design method, Public Works Research Institute Material, No.2539 .
- Fujiwara, et al.(1989) : Estimation of design live load in limit state design method, Public Works Research Institute Material, No. 2700.
- Sugiyama, et al.(1990) : Probabilistic consideration of load combination factors, Journal of Structural Engineering, Vol.36A, pp.479-490 .
- Steel and concrete common structural design standards subcommittee(1992) : Common principles in limit state design methods for steel and concrete structures, Proc. of JSCE, No.450/I-20 , pp.13-20 .
- Okada, et al.(1993) : Maintenance of highway bridges (foundations), Hanshin Expressway Management Technology Center , pp.175-178 .
- Kiichiro Muta(1993) : Fire, repair, and reinforcement, Concrete technology, Vol.31, pp.83-86 .
- Ministry of Const. Pubic Works Research Institute, Steel Products club, Japan Bridge Const. Society(1993) : Joint research report (XX) on application of atmospheric corrosion resisting steel to bridges - Course of design and erection of bridges constructed from unpainted atmospheric corrosion resisting steel (revised version), Joint research report, No.88.
- Ishii, et al.(1994) : Various problems relating to hydraulic structures (Vibration of long span shell-type water sluice caused by fluid motion), Journal of Japanese Wind Engineering Association, 59 , pp75-79.
- Tsuda, et al.(1995) : Experiment on characteristics of concrete exposed to exhaust gases for more than 30 years, Journal of JSCE Annual meeting, No. 50 , pp258-259.
- Tsuda, et al.(1996) : Chemical analysis of reinforced concrete of age more than 30 years, Journal of JSCE annual meeting No. 51 , pp322-323.
- Japan Society of Civil Engineers(1998) : Design Code for Steel Structures, PART A; Structures in General.
- JSCE Earthquake Engineering Committee - Research subcommittee for Level 2 earthquake motion(1993) : Research activity report of Research subcommittee for Level 2 earthquake motion.
- Railway Technical Research Institute(2000) : Standard Specifications for Railway Structures and Commentary, Steel and Composite structures.
- Japan Highway Public Corporation(2000) : Design Guide Vol. 2, Bridge Design Volume.
- Nippon Expressway Company Limited (2006) :
- Japan Society of Civil Engineers (2001) : Guideline of earthquake-resistant design for civil structures (Draft) - Handbook for Preparation of Earthquake-resistance Design Standards - .
- Toshio Fukushima(2001) : Trend of atmospheric CO₂ concentration and new prediction and estimation methods for neutralization progress of concrete, Journal of Global Environment Symposium, No.9 pp.151-156 .
- Honshu-Shikoku Bridge Authority(2001) : Wind-resistant Design Standards for Honshu-Shikoku Bridge and Commentary.
- Railway Technical Research Institute(2002) : Standard Specifications for Railway Structures and Commentary, Composite Structures with Steel and Concrete.
- Shirase, et al.(2002) : Estimation of effect of adhering nitrogen oxides on the durability of RC highway bridges, Journal of JSCE annual meeting, No. 57,pp.1075-1076 .
- Japan Society of Civil Engineers(2002a) : Standard Specification for Concrete Structures, Structural Performance Verification Volume.
- Japan Society of Civil Engineers(2002b) : Standard Specification for Concrete Structures, Construction Volume.
- Japan Concrete Engineering Association(2002) : Report of research committee on safety of concrete structures against fire.
- Japan Road Association(2002a) : Specifications for Highway Bridges and Commentary, I General Volume.
- Japan Road Association(2002b) : Specifications for Highway Bridges and Commentary, III Concrete Volume.
- Japan Road Association(2002c) : Fatigue Design Recommendations for Steel Highway Bridge.

Railway Technical Research Institute(1992) : Design Standards for Railway Structures and Commentary, Steel and Composite Structures .

Japan Road Association(2005) : Wind-resistant Design Manual for Highway Bridges.

BS5400(1978) : BS5400 Part 1 , British Standards Institution .

OHBD(1983) : Ontario Highway Bridge Design Code , Ministry of Transportation and Communications , Ontario .

AASHTO(1996) : AASHTO Standard Specification for Highway Bridges , 16th Edition .

Chapter 3 Materials

3.1 General

3.1.1 Fundamentals of material physical properties

Regarding basic physical properties, the materials used in steel and composite structures must satisfy the following requirements:

- (1) Adequate strength and deformability, or toughness
- (2) Resistance to change or deterioration in quality during the working life
- (3) Minimum impact on the environment
- (4) Minimum impact on human beings and animals/plants

【Commentary】

This article describes the fundamental properties required of the materials used in steel and composite structures. These include materials used for structural members (e.g. steel and concrete), for attachments and pavements (e.g. rubber, plastic and asphalt), for welding and painting, for improvement of service and for maintenance.

- (a) The fundamental performance requirement of materials forming the structure is that they should be able to resist actions such as the various loadings to which the structure is exposed.
- (b) Materials forming the structure should not reach unexpected limit states as a result of deterioration phenomena during the working life of the structure.
- (c) Materials-related energy consumption and CO₂ discharges should be minimized, while recyclability should be high.
- (d) Any materials that escape into the surrounding environment during construction and service should not have a strong impact on human beings, animals and plants.

3.1.2 Required properties of materials

- (1) The materials used in steel and composite structures must have properties that are sufficient to meet the required performance.
- (2) Material properties must be described using measurable physical quantities and be consistent with the calculation model.

【Commentary】

- (1) Any materials that escape into the surrounding environment during construction and service should not have a strong impact on human beings, animals and plants.
- (2) Corresponding to design requirements, the materials should be evaluated to ensure that their properties are suitable with respect to strength (tensile, compressive and shear), deformation (e.g. elastic modulus), heat-resistance and water-tightness.

Material properties and their characteristic values should be determined by tests specified in the standards, such as ISO and JIS, or by other widely accepted methods. These tests should be carried out on the basis of random samples representing the overall population. The characteristic values obtained from tests on such specimens should be converted to suit the design calculation models using appropriate conversion factors or functions. However, since details of materials are generally not yet

identified at the design stage, it is also rational to determine characteristic values from statistical values rather than actual experiment [ISO, 1998]. Values specified in standards such as ISO and JIS should then be used as characteristic values; alternatively, characteristic values should be determined such that the probability of actual values being less than those values is a defined small value [JSCE, 1992].

3.2 Structural Steel

3.2.1 Required steel properties

- (1) The mechanical properties, chemical composition, shape, and dimensions of structural steel must satisfy the structure's required performance.
- (2) Structural steel conforming to standards such as ISO and JIS and that has a long history of use in past projects is deemed to satisfy requirement (1). Such material can be used once conformity with the standards is confirmed through inspection certificates.

【 Commentary 】

- (1) The required performance of the steel materials used in steel and composite structures is prescribed. These steel materials should possess the required properties and qualities in order that the structure or structural member that these steel materials are used meets the required performance such as safety, durability, fabricability, etc. [Japan Road Association, 2002a].

Also, the properties and qualities of the steel materials should satisfy the performance requirements throughout the planning, design, construction, and maintenance stages.

- (2) In general, steel and composite structures are designed based on assumptions about the properties and qualities of the materials to be used. Therefore, a precondition for the use of all materials is that stable quality can be assured. Since there is some variability in the properties of industrial products, the average or the distribution of each property should meet the requirement. Quality is commonly controlled using standards such as ISO and JIS. Structural steel materials conforming to standards such as ISO and JIS and that have been used in many structures in the past are deemed to satisfy the requirements of (1) above. Thus, such steel materials can be used after confirming conformance with the standards by inspecting the certificates [Japan Road Association, 2002a; JSSC, 2004].

Recently, new steel materials with improved properties and qualities have come into use for the purpose of rationalizing fabrication and improving durability (3.2.2 (2)). Most of these new materials are produced by improving the chemical composition or rolling method for standard materials, such as specified by ISO and JIS. These new steel materials can be used in structures after confirming the influence of any changes from the standards on structural performance through experiments or other means. Also, since the qualities of these steel materials are deemed to meet the same ISO and JIS standards, they can be used after confirming their conformity with the standards by inspecting the certificates. Any steel materials with properties that deviate from the standards can be used in the same way.

3.2.2 Selection of steel type

- (1) The type of steel used for a steel or composite structure must be selected according to the required material properties, which depend on the stress state where used, environmental conditions at the site, corrosion protection method, construction method, and so on. The properties of interest include strength, ductility, toughness, chemical composition, shape, size, and surface characteristics.

- (2) A variety of types of steel is available depending on the requirements of quality control, workability, labor-saving, etc.. The selected material shall be demonstrated to have properties that satisfy the objective through an appropriate procedure such as testing.

【Commentary】

- (1) The fundamental principles for the selection of steel type are prescribed [Japan Road Association, 2002b]. Particular consideration should be given to the selection of steel type in the following cases.

- 1) For seismic energy and deformation absorbing members

In the Design Specifications for Highway Bridges Part VI [Japan Road Association, 2002c] damage tolerance design is adopted on condition that there should be no bridge collapses or repairable after Level 2 ground motions. For example, there is one design in which the steel bridge piers have no concrete filling, allowing the structural members to yield and absorb the seismic energy in Level 2 ground motions. In this case, the premise is that there should be no damage such as fractures to the structural members or the joints. Thus, the stress-strain curves after yielding [JSCE, 2000; Tominaga et. al, 1994], fracture toughness [Sasaki, 2000], and z-tension test results [Japan Road Association, 2002b] should be considered in selected energy and deformation absorbing members.

- 2) For use in regions with low temperatures

Brittle fractures at low temperature should be considered. Adequate toughness taking into account the lowest temperatures experienced in the region should be ensured for steel materials used in important welded structural members in tension. Certain special regulations for the selection of steel types for cold regions may be useful [Japan Road Association, 1985]. In the regulations of the Hokkaido Development Bureau, there are three categories of cold according to the lowest temperature (lowest temperature ≤ -35 , $-35 < \text{lowest temperature} < -25$, $-25 \leq \text{lowest temperature}$) and corresponding usable steel types are decided accordingly.

- 3) For structural members subjected to significant welding restraint or tensile force in the thickness direction

Where there are welds such as cruciform joints, T-shaped joints, or corner joints, or where structural members are subjected to tensile force in the thickness direction, a fracture in the thickness direction known as a lamellar tear may occur. Lamellar tearing is a phenomenon in which sulfide inclusions (MnS) in the steel become elongated through rolling; tearing then happens because of tensile force in the thickness direction acting between the inclusions and the steel. Consequently, the concentration of sulfide inclusions is related to the evaluation of susceptibility to lamellar tearing.

To avoid lamellar tearing, consideration should be given to selecting a suitable joint type (weld design), reducing the force or strain in the thickness direction (welding procedure), or adoption of lamellar tear resistant steel [JSCE, 1985].

- 4) For structural members bent to a small radius

For the purpose of landscape design or rationalized structural design, structural members worked to a small radius are increasingly being used. Steel hardens with bending due to strain aging. To minimize the influence of strain aging embrittlement, it is important not to introduce large local strains. In general, the inside bending radius should be greater than 15 times the steel thickness so that surface strain does not exceed about 3%. However, this rule does not apply to steel materials with enhanced toughness prescribed later or if it has been confirmed that strain aging embrittlement does not occur.

- 5) In the case of welding with low preheating temperature

Welds may crack because of the presence of hydrogen in cases where there are a lot of alloying elements in the steel and where they are subjected to significant welding restraint. In general, the steel is preheated to prevent weld cracking. Lower preheating temperature are desired because preheating leads to much work in fabrication and work conditions are not good.

To prevent weld cracking it is effective to reduce PCM which is an indicator of the susceptibility to weld cracking. Further, the type of welding materials (diffusible hydrogen) and shape of joints (thickness, degree of restraint) should be considered in deciding the preheating temperature.

6) In the case of large heat input welding

Large heat input welding with reduced welding passes realizes a rationalization of work when field welding the full cross section of the I-girders in a twin I-girder bridge. The heat input has to be restricted according to the type of steel because, in general, the heat-affected zone becomes weaker in proportion to the heat input. Recently, new types of steel that allow for large heat input welding have been developed. These steel materials can be used after confirming their quality through welding tests. However, it should be noted that proper welding materials must be selected for the welding to ensure the required performance of the welded metal.

(2) High performance steels [JISF, 2005] exhibit improved properties of strength, toughness, bending formability, and corrosion resistance than conventional types of steel. The use of such high-performance steel materials is prescribed here.

1) Excellent toughness steels

Where cold bending work of structural members is carried out, the inside bending radius of curves should be greater than 15 times the thickness because of the problem of loss of toughness. However, where sufficient toughness can be secured by using excellent toughness steels, bends with smaller inside bending radius are permitted. Specifically, bends with an inside bending radius of 5 or 7 times the thickness or greater are permitted if the result of Charpy impact tests for absorbed energy, as specified in JIS Z2242, satisfy the values given in Table C3.2.1 and the N content of the steel is $\leq 0.006\%$.

In general, steel toughness declines and the risk of brittle fracture tends to rise at lower temperatures. These problems can also be improved by using excellent toughness steels.

Table C3.2.1 Allowable radius in cold bending work

Charpy absorbed energy	Inside bending radius in cold bending work
150J and over	7t and over (t: thickness)
200J and over	5t and over (t: thickness)

2) Lamellar tear resistant steels

Welded joints subjected to large tensile force in the thickness direction can fracture in the thickness direction in a so-called lamellar tear. Where this is a concern, a lamellar tear resistant steel can be used along with improved welding methods. Lamellar tear resistant steels with guaranteed z-tension test results and sulfur content are specified in JIS G3199. (See Table C3.2.2)

Table C3.2.2 Results of z-tension tests and sulfur content (JIS)

Class	Average of 3 specimens	Value of each specimen	Sulfur content
Z15S	15% and over	10% and over	0.010% and under
Z25S	25% and over	15% and over	0.008% and under
Z35S	35% and over	25% and over	0.006% and under

3) LP steel plates

Longitudinally profiled (LP) steel plates are produced with variable thickness in the longitudinal direction. LP steel plates have become available due to the development of plate rolling technology. The application of LP steel plates to steel and composite structures allows the weight of steel, and hence fabrication cost, to be reduced while eliminating filler plates in bolted joints and eliminating tapering work in welded joints.

4) Low preheating steels

With increasing the amount of alloying elements and with increasing steel thickness, the problem of weld cracking tends to increase. In order to prevent weld cracking it is necessary to preheat the steel. Low preheating steels whose PCM is lower than that of conventional steel materials allow the preheating temperature to be reduced or allow reduction or elimination of preheating work.

5) Steels for large heat input welding

In general, as the amount of heat input by welding increases, the heat affected zone tends to become weaker. Where this causes a problem, special steels for large heat input welding allow the required toughness to be secured. When using such steel materials, the welding equipment, groove shapes, and welding conditions should be checked against the Design Specifications for Highway Bridges 17.4.4 [Japan Road Association, 2002b] .

6) Constant yield point steels

In general, as the thickness of steel increases, its yield point or strength tends to decrease. Constant yield point steels provide the benefit of reduced steel weight and reduction in design complexity where the steel exceeds 40 mm in thickness.

7) Low yield strength steels

Low yield strength steels have excellent ductility and are used for seismic vibration control devices in structures. These low yield steels absorb the seismic energy through plastic deformation, thereby reducing the vibration of the structure.

8) Nickel added weathering steels

Nickel added weathering steels whose mechanical properties are in conformity with JIS SMA and whose corrosion resistance is improved have come into use. These weathering steels, which are Cr-free low alloy steels containing Ni, Cu, Mo, Ti, etc., are applicable over a larger range than conventional weathering steels (JIS G 3144).

9) Stainless steels

Stainless steels are used for harbor, offshore, and river structures, etc. where regular corrosion prevention is difficult to implement. In addition to conventional stainless steel (SUS304), various new kinds of stainless steel with improved corrosion resistance and Ni-free ferritic stainless steels have been developed. These stainless steels have been used for bridges as well as buildings in Europe and the USA. Considering the reduced maintenance, improvement in LCC is expected for the adoption of the stainless steels because of excellent corrosion resistance.

10) Bridge high-performance steels

Bridge high-performance steels (BHS) whose yield strength, tensile strength, toughness, weldability, fabricability, and weather resistance are highly developed, have been proposed

[Miki et. al, 2003], and some research relating to their application to actual structures has been conducted. Utilization of the excellent performance of BHS is expected to reduce bridge construction costs.

3.3 Concrete

- (1) The strength, ductility, and workability of concrete must be of specific quality suitable for construction.
- (2) Ready-mixed concrete shall conform to JIS A 5308 in principle.

【Commentary】

- (1) This article derives from the materials provision (3.2.1) in the Design Specifications for Highway Bridges [JRA, 2002a]. Designers may also follow the Standard Specification for Concrete Structures [JSCE, 2002].
- (2) This article is included since most construction in Japan is carried out with ready-mixed concrete. Even using ready-mixed concrete, though, the required properties cannot be obtained unless construction work is carried out appropriately. Care is necessary during construction since even material sourced from a plant certified by JIS may suffer from some problems. In order to meet structure performance requirements, the use of high-performance concretes not conforming to JIS, such as high-strength, high-fluidity, high-self-compactability, and low-heat of hydration concretes, is increasing. The mix-proportion required to satisfy such specific performance requirements should be determined based on the provisions of the Standard Specifications for Concrete Structures [JSCE, 2002].

3.4 Value of Material Properties for Design

3.4.1 General

- (1) The quality of steel or concrete is expressed not only in terms of tensile or compressive strength but also through other material properties such as strength, deformation, heat, durability, or water tightness according to design needs. Appropriate consideration must be given to the influence of loading rate on strength and deformation properties.
- (2) The characteristic value of material strength, f_k , should be selected such that most test values fall above it.
- (3) Design material strength, f_d , is given by the characteristic value of material strength, f_k , divided by the partial factor for the material, γ_m .

【Commentary】

- (1) The main materials used in steel and composite structures are steel and concrete. Many varieties of steel and concrete are available, so it is necessary to select appropriate ones in consideration of how the structure will be used, environmental conditions, design working life, construction conditions and so on.

Material properties are expressed not only in terms of tensile or compressive strength but also through other values according to design needs. The various material properties can be classified into mechanical, physical and chemical properties.

Strength properties can be expressed through measures of static strength, such as tensile

strength, yield strength (yield point or proof stress), compressive strength and bond strength, as well as fatigue strength, fracture toughness and so on. Deformation properties include time-independent Young's modulus and Poisson's ratio, as well as time-dependent creep modulus and shrinkage. In addition, there are the properties expressed through the relationship between two mechanical factors, as in the case of a stress-strain curve. The physical properties include heat properties, such as coefficient of thermal expansion and specific heat, as well as density, water-tightness and air-tightness. The quantitative treatment of density and heat properties is generalized. Acid erosion and resistance to sulfates are classified as chemical properties.

The values of material properties specified in this chapter can be used in the examination of limit states under static or dynamic loading. However, values obtained through reliable experiments should be used in cases where strain rate has a significant influence on strength or deformation properties, e.g. when examining impact loading.

- (2) The characteristic value of material strength f_k is calculated from test results using Eq.(C3.4.1).

$$f_k = f_m - k \sigma = f_m (1 - k \delta) \quad (\text{C3.4.1})$$

Where, f_m : mean of test values, σ : standard deviation of test values, δ : coefficient of variation of test values and k : coefficient.

Coefficient k is determined from the probability of obtaining a test value less than the characteristic value and the probability distribution of test values. The 5% fractile value is often taken as the characteristic value. In this case, the value of coefficient k is 1.64 if the normal distribution is assumed for the test values. For ready-mixed concrete conforming to JIS A 5308, the probability of obtaining concrete strength less than the nominal strength is approximately 4%, since it is specified that each test value must be more than or equal to 85% of the nominal strength and the mean of three test values must exceed the nominal strength. Therefore, the corresponding k value is 1.73.

When the lower limit of strength is guaranteed by a standard such as ISO or JIS, this value can be taken as the characteristic value. An example of a guaranteed steel strength is given in Table C3.3.1.

Table C3.3.1 Example of guaranteed steel strength(N/mm²)

Steel type	SM400 SM400 SMA400	SM490	SM490Y SM520 SMA490	SM570 SMA570	Applicable plate thickness
Yield point or proof stress	235	315	355	450	Less than or equal to 40mm
	215	295	335	430	More than 40mm

For load-carrying welded joints, the strength can be taken as the same as the base metal, provided that appropriate welding materials are used and sufficient quality control is implemented by a qualified welding engineer.

3.4.2 Structural steel

(1) Strength

- 1) The characteristic values of tensile yield strength, f_{yk} , and tensile strength, f_{uk} , should be determined based on values obtained through tensile tests.
- 2) The guaranteed value shall be taken as the characteristic value, f_{yk} and f_{uk} , for a material conforming to a standard such as ISO or JIS. In general, the nominal value of cross sectional area shall be used for design calculations.
- 3) The characteristic value of compressive yield strength, f'_{yk} , shall be considered to be

equal to that of tensile yield strength, f_{yk} .

- 4) In general, the characteristic value of shear yield strength shall be obtained using Equation (3.4.1).

$$f_{vyk} = \frac{f_{yk}}{\sqrt{3}} \quad (3.4.1)$$

- (2) Fatigue strength The characteristic value of fatigue strength shall be determined based on fatigue tests in which type of steel, shape, size, welding process, residual stress, fabrication errors, the histogram of applied stress range, and environmental conditions are taken into consideration.
- (3) Stress-strain curve
- 1) An appropriate stress-strain curve should be determined according to the objective of the examination.
 - 2) In verification for safety, the stress-strain curve shown in Figure 3.4.1 can be used.

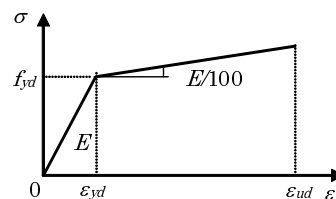

Fig.3.4.1 Stress-strain curve of steel

- (4) Young's modulus
- 1) In principle, Young's modulus of the steel shall be determined through a tensile test conforming to a standard such as JIS Z 2241.
 - 2) Young's modulus of steel can be generally taken as 205kN/mm².
- (5) Poisson's ratio
Poisson's ratio of steel can be generally taken as 0.3.
- (6) Coefficient of thermal expansion
The coefficient of thermal expansion of steel can be generally taken as $1 \times 10^{-5} / ^\circ\text{C}$.

【 Commentary 】

- (1) In principle, the characteristic value of yield strength (yield point or proof stress) should be determined through tests. However, the guaranteed value is to be taken as the characteristic value for a material conforming to a standard such as ISO or JIS, since strengths more than or equal to the guaranteed value have been obtained in previous tests.

According to JIS Z 2241 "Method of tensile test for metallic materials", the cross-sectional area used to calculate strength should be the value measured before the test for structural steels and, in the case of concrete reinforcing steel, the nominal value. Although this does not necessarily yield a conservative value of strength because of allowable error in the product size, the use of the nominal cross-sectional area is permitted for design calculations since such over-estimation of strength does not have significant influence on the performance verification.

The behavior of steel in compression tests is fundamentally the same as that in tensile tests. Consequently, yield points based on the true stress are the same in compression and tension. The yield strength obtained by JIS Z 2241 is not based on the true stress, because the cross-sectional area measured before the test is used in the stress calculation. However, the influence of this on the limit state examination is not significant, so the compressive yield strength should be considered equal to the tensile yield strength.

According to von Mises yield criterion, the characteristic value of shear yield strength can be obtained using Equation (3.4.1).

- (2) Most fatigue problems occur at welded joints. The factors influencing the fatigue strength of a welded joint can be considered to be steel strength, joint type, welding process and condition, plate thickness, degree of misalignment (axial or angular), presence of weld defects, existence of weld root, stress ratio (minimum stress/maximum stress) and residual stress due to welding. The fatigue strength of a weld increases with increasing steel tensile strength. However, steel strength barely influences the fatigue strength of welded joints. The degree of stress concentration is related to joint type, welding process and condition, plate thickness, fabrication errors (axial or angular misalignments), weld defects and existence of weld root. Therefore, in tests to evaluate fatigue strength, it is important to reproduce the conditions of stress concentration and stress ratio, including the effect of residual stress, occurring in the actual structure as closely as possible. In particular, attention should be paid to residual stress since it differs between small specimens and actual structures due to the difference in restraint level. In Fatigue Strength Recommendation for Steel Highway Bridges [JRA, 2002d], the fatigue strength (S-N curve) is given for typical welded joints based on the results of an enormous number of past fatigue tests. This data should in general be used for fatigue design. The design fatigue strength of reinforcing bars should be determined according to Standard Specifications for Concrete Structures "Structural Performance Verification" [JSCE, 2002].
- (3) The stress-strain curve of steel can be generally expressed using a model that consists of an elastic region, a yield plateau and a strain hardening region, as shown in Fig.C3.4.1 [JSCE, 1996]. However, the actual shape of the curve varies with the type, chemical composition and production method of the steel. The equations and parameters in them are modeling examples. There are other models such as the Ramberg-Osgood model, the Swift model, the Ludwik model and the n-th power hardening rule. Consequently, a model suitable for the purpose of the examination should be selected. Although a perfect elasto-plastic stress-strain relationship would be expected to give the most conservative result, the bi-linear type stress-strain relationship with a strain hardening slope of $E/100$ given here is specified for safety verification since most of the steel used for structures has a strain hardening region. The strain hardening slope of $E/100$ can be roughly considered as a straight line connecting the yield point and the 5% strain point.

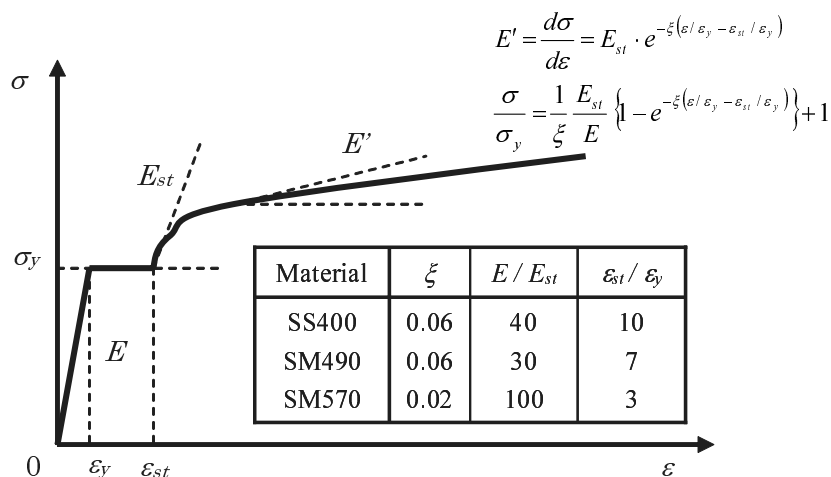

Fig.C3.4.1 Stress-strain curve of steel with yield plateau and strain hardening region [JSCE, 1996]

- (4) Values of the Young's modulus of steel as specified in certain design codes are given in Table

C3.4.1. Four in six codes specify a value of 200kN/mm^2 . However, it is prescribed here that the Young's modulus should be 205kN/mm^2 , which is closest to the conventionally used value of $2.1 \times 10^6\text{kgf/cm}^2$ in order to maintain consistency with the design code for buildings.

Table C3.4.1 Values of Young's modulus in certain design codes (kN/mm^2)

Specifications for Highway Bridges [JRA, 2002a]	Standard Specifications for Concrete Structures [JSCE, 2002]	Design Standard for Steel Structures [AIJ, 2005]	Eurocode 3 [CEN, 2003]	AASHTO LRFD [AASHTO, 1998]	Canadian Highway Bridge Design Code [CSA, 2000]
200	200	205	210	200	200

3.4.3 Concrete

The strength, stress-strain curve, Young's modulus, Poisson's ratio, and the other material properties of the concrete shall be determined through tests.

【Commentary】

This article designates the principles for determining design values for the material properties of concrete. Generally, the values specified in Standard Specifications for Concrete Structures [JSCE, 2002] should be used.

3.5 Partial Factors for Materials

The partial factors for materials shall be properly determined in consideration of adverse variations in strength from characteristic values, variations between properties in specimens and actual structures, the influence of properties on limit states, changes in properties with time, and differences between real characteristic values and values assured by standards such as ISO and JIS.

【Commentary】

This provision specifies the considerations to be taken in determining the partial factors for materials.

Concerning structural steel, the values of material partial factor γ_m as given in Standard Specifications for Concrete Structures [JSCE, 2002] and Eurocode 3 [CEN, 2003] are shown in Table C3.5.1. In verifying ultimate limit states according to Eurocode 3, the values 1.0 and 1.25 are used for the resistance of cross sections to excessive yielding, including local buckling, and for the resistance of cross sections in tension to fracture, respectively. The value of the partial factor for the fatigue limit is specified according to the consequences of failure and the assessment method (i.e. the damage tolerant method or the safe-life method). Ultimate limit states, fatigue limit states and serviceability limit states in Table C3.5.1 can be thought of as corresponding to verifications for safety, durability and serviceability, respectively, in these specifications.

The mean yield point of Japanese-manufactured structural steel conforming to JIS is approximately 1.2 times the guaranteed value [Nara et al., 2004]. Taking the 5

One study [JSCE, 1994] reported that the difference in mean and standard deviation between the upper and lower yield points is approximately 3.5%. There is also a report showing that tensile tests according to JIS give a yield point approximately 10% higher than the static yield point [JSCE, 1994].

Table C3.5.1 Examples of partial factors for steel γ_m

Limit state	Standard Specifications for Concrete Structures [JSCE, 2002]	Eurocode 3 [CEN, 2003]
Ultimate limit	1.05	1.00~1.25
Fatigue limit	1.05	1.00~1.35
Serviceability limit	1.0	1.00

Furthermore, the fatigue strength specified for each joint type in Fatigue Design Recommendations for Steel Highway Bridges [JRA, 2002d] corresponds to the lower bound of test results using a specimen of the required quality or 97.7% fractile value.

Accordingly, it can be concluded that, for structural steel conforming to a standard such as ISO or JIS, the value of γ_m should be 1.0 in verifications of structural safety, serviceability and durability, as long as the guaranteed yield point and fatigue strength specified in the Fatigue Design Recommendations are taken as the characteristic values of static strength and fatigue strength, respectively.

The allowable stress of JIS-SM570 in Specifications for Highway Bridges is determined so as to maintain a safety factor of 1.7 against the yield point and 2.2 against tensile strength. Accordingly, safety against tensile strength is $2.2/1.7=1.29$ times higher than that against the yield point. Considering this, and referring to overseas design codes such as Eurocode, it is considered that the safety of members against fracture can be verified using the characteristic value of guaranteed tensile strength and a material partial factor of 1.25.

References in Chapter 3

- Japan Road Association(1985) : Construction Handbook of Steel Bridges, Maruzen.
- Japan Society of Civil Engineers(1985) : Application of Lamellar-Tearing resistant steel to civil structures, Civil engineering.
- Japan Society of Civil Engineers(1992) : General principles for the limit state design of steel and concrete structures, Journal of Structural Mechanics and Earthquake Engineering, No.450/I-20, pp.13-20.
- Japan Society of Civil Engineers(1994) : Ultimate Strength and Design of Steel Structures, steel structures series 6 .
- T. Tominaga and H. Yasunami(1994) : An experimental study on ductility of steel bridge piers with thick walled cross section and small number of stiffeners, Journal of Structural Engineering, Vol.40A, pp.189-200.
- Japan Society of Civil Engineers(1996) : Tentative seismic design recommendations for steel bridges and new technologies for seismic design.
- American Association of State Highway and Transportation Officials (1998) : LRFD Bridge Design Specifications, SI Unit Second Edition.
- ISO(1998) : ISO2394 General principles on reliability for structures .
- Canadian Standards Association (2000) : Canadian Highway Bridge Design Code.
- Sasaki, E.(2000) : An examination on required fracture toughness of steels for bridges, Report of study on application of high performance steel to bridges, JSSC, pp.58-67.
- Japan Society of Civil Engineers and Japanese Society of Steel Construction(2000) : Benchmark for seismic analysis of steel structures and improvement of seismic design method.
- Japan Society of Civil Engineers (2002) : Standard Specification for Concrete Structures, Structural Performance Verification Volume.
- Japan Road Association(2002a) : Specifications for Highway Bridges and Commentary, I Common Specifications Volume.
- Japan Road Association(2002b) : Specifications for Highway Bridges and Commentary, II Steel Highway Bridges.

- Japan Road Association(2002c) :Specifications for Highway Bridges and Commentary, V Earthquake-resistance Design Volume.
- Japan Road Association(2002d) : Fatigue Design Recommendations for Steel Highway Bridges.
- CEN(2003) : Eurocode 3 Design of Steel Structures - Part 2: Steel Bridges -, prEN 1993-2 .
- Miki, C., Ichikawa, A., Kusunoki, T., and Kawabata, F.(2003) : Proposal of new high performance steels for bridges (BHS500, BHS700), Journal of Structural Mechanics and Earthquake Engineering, No.738/I-64, pp.1-10.
- Japanese Society of Steel Construction(2004) : International harmonization guideline of design standards for steel structures, Steel bridges, JSS IV 06-2004.
- Nara, T., Nakamura, S., Yasunami, H., Kawabata, F., and Shiwaku, T.(2004) : A statistical survey on thickness and mechanical properties of structural steel plates for bridges, Journal of Structural Mechanics and Earthquake Engineering, No.752/I-66, pp.299-310.
- Japan Iron and Steel Federation(2005) : High performance steels for bridge construction.
- Architectural Institute of Japan (2005) : Design Standard for Steel Structures - Based on Allowable Stress Concept -.

Chapter 4 Structural Analysis

4.1 General

- (1) The structural analysis carried out must be relevant to the verification method used.
- (2) It is important to note that structural analysis may not be always an appropriate means of verification.

【 Commentary 】

- (1) For the purpose of performance verification, an index is specified for each performance requirement. Typical indexes are section force, displacement, and strain. Performance is then verified by comparing the value of the index under the appropriate action with the limit value; the value of the index under this action is treated as the demand, while the limit value is considered the capacity of the structure. In general, structural analysis is the process of evaluating the behavior of the structure under the design actions to obtain the value of the index. Linear structural analysis is often sufficient to achieve this end. It is also possible to verify performance by evaluating the load-carrying capacity of the structure and comparing it with the design actions, but when this procedure is used, nonlinear structural analysis is required. The appropriate method of analysis therefore depends on the type of performance verification being carried out.

Structural analysis requires that the structure be modeled. In general, modeling is regarded as a simplification of reality that retains its important characteristics. In short, a model must be able to simulate reality up to the limit state. Models can be classified into three groups: action models, structure models, and resistance models [ISO 1998]. A structure model is one in which the value of the index is evaluated, while a resistance model is one by which the limit value in terms of the index is evaluated. It must be noted, however, that the distinction between model types is not always clear. A case in point, for example, is the instability of a structural system as a whole where there is significant interaction between action and structural behavior.

Most structural analysis is these days based on the finite element method. In the construction of a finite element analysis (FEA) model, careful attention is also required with respect to the types of elements used, the number of elements, and the layout of elements. For structural members that are much larger in one dimension than in the others, beam elements may be used; where two of the dimensions are much larger than the other, plate/shell elements may be used. Otherwise, solid elements may need to be employed. However, there are no clear-cut criteria by which to judge which type of element should be used in modeling. A plate/shell element is more generic than a beam element, which means that the assumptions employed in developing such an element are less restrictive and it is likely to behave closer to reality. The same is true with plate/shell elements and solid elements; the latter are more generic. However, the use of more generic elements results in increasing data inputs and longer computation times. Still, advances in computer technology and FEA software in recent years have made it easier to use generic elements. Against this background, the Fatigue Design Guidelines for Steel Bridges give structural analysis factors for several types of structural analysis [JRA 2002].

Regardless of the type of element, it is essential to construct an appropriate finite element mesh. Failure to do so would lead to unreliable results. Bearing this and other points in mind, it is clear that finite element analysis can yield only approximate results and its accuracy can vary

from analysis to analysis. The appropriate analysis that this clause requires means choosing an appropriate analysis method and constructing an appropriate analysis model. Some of the basics involved in choosing an appropriate analysis method are explained below.

Linear Analysis

When the applied load is small, a structure's deformation is generally small and linearly proportional to the magnitude of the load. Linear analysis, also often called small-displacement analysis, is appropriate for this type of structural behavior. In the design of the civil infrastructure, this is usually the class of analysis used. Since the principle of superposition is valid in linear analysis and thus the following equation holds true, results for various load combinations and influence-line loads are very easily obtained:

$$\sum_{i=1}^N \mathbf{F}_i = \mathbf{K} \left(\sum_{i=1}^N \alpha_i \mathbf{U}_i \right) \quad (\text{C4.1.1})$$

where α_i = load factor, N = the number of loads to be combined, \mathbf{F}_i = load vector to be combined, \mathbf{K} = stiffness matrix, \mathbf{U}_i = displacement vector due to \mathbf{F}_i . Since, in finite element analysis, the components \mathbf{F}_i and \mathbf{U}_i are the load and the displacement at a node, are called the nodal load vector and the nodal displacement vector, respectively.

Nonlinear Analysis

When strain and displacement become large, linear analysis tends to produce significant errors because their effects are ignored. In such situations, the deformed configuration of a structure is distinctly different from its original configuration. Since a structure's stiffness depends on its configuration, the structural response changes as deformation progresses; this change in configuration must be taken into consideration in analysis. The relationship between load and deformation is nonlinear. The class of analysis required is called the geometrically nonlinear analysis or finite displacement analysis. It must be noted that large displacement does not necessarily mean large strain. A fishing rod can undergo large displacement without large strain, for example. Therefore, geometrically nonlinear analysis can be grouped into two types: finite strain-finite displacement analysis and small strain-finite displacement analysis.

As deformation increases, the material of the structure exhibits a nonlinear response. The plastic deformation of steel is a typical example. This type of phenomenon also requires nonlinear analysis; this is known as material nonlinear analysis.

Analysis that takes into account the effects of both geometrical nonlinearity and material nonlinearity is often required in the analysis of steel structures when ultimate strength is of interest.

The weighted residual method and the finite element method lead to the following general discretized equilibrium equation:

$$\mathbf{F} = \mathbf{K}(\mathbf{U}) \quad (\text{C4.1.2})$$

where \mathbf{F} is the external force vector, \mathbf{K} is the internal force vector, and \mathbf{U} is the displacement vector. Usually proportional loading is applied so that Eq.(C4.1.2) can be rewritten as

$$\alpha \mathbf{F}_0 = \mathbf{K}(\mathbf{U}) \quad (\text{C4.1.3})$$

where \mathbf{F}_0 is the base load vector and α is the load parameter.

Equilibrium Path

In some kinds of nonlinear analysis, only the displacement caused by a specific load is of

interest. However, in many other cases, the load \mathbf{F} versus displacement \mathbf{U} relationship that satisfies Eq.(C4.1.2) is evaluated and the load \mathbf{F} versus displacement \mathbf{U} curve is plotted. This curve is called the equilibrium path.

Today, most nonlinear structural analysis is conducted using the finite element method. Therefore, Eq.(C4.1.2) takes the form of a set of nonlinear equations to which exact solutions are rarely available. Instead, solutions are obtained numerically. A popular method is the Newton-Raphson technique in which the equation is linearized and solved repeatedly until convergence is reached,

When the equilibrium path is targeted, certain variables are picked out and given values. The values of the remaining variables are then calculated. Depending on the variables chosen, three groups of approaches are available: (1) load control; (2) displacement control; and (3) arc-length control.

In a load-control approach, the value of α is given and, if the Newton-Raphson method is used, the following set of equations is to be solved repeatedly to obtain the solution:

$$\alpha \mathbf{F}_0 - \mathbf{K}(\mathbf{U}^{(m)}) = \mathbf{K}_T(\mathbf{U}^{(m)}) \Delta \mathbf{U}^{(m)} \quad (\text{C4.1.4})$$

$$\mathbf{U}^{(m+1)} = \mathbf{U}^{(m)} + \Delta \mathbf{U}^{(m)} \quad (\text{C4.1.5})$$

where, \mathbf{K}_T is the tangent stiffness matrix defined by $\partial \mathbf{K} / \partial \mathbf{U}$. Eq.(C4.1.4) is the linearized equilibrium equation, a set of simultaneous linear equations. Solving this set, the displacement vector is updated using Eq.(C4.1.5). This computation is continued until $\Delta \mathbf{U}^{(m)}$ becomes sufficiently small that convergence can be considered as achieved. In the above equations, superscript (m) indicates the number of repetitions of this computation. It is noted here that the construction of the tangent stiffness matrix \mathbf{K}_T requires an incremental constitutive model (an incremental stress-strain relationship). Besides, in addition to the update of the displacement vector, the stress states need to be updated.

There is a limit load that a structure can carry. To evaluate this limit, analysis must continue beyond the limit, exploring the deterioration of the structure. It is difficult to use load control for this class of analysis. Instead, displacement control may be used since, in many cases, some displacement components continue to increase even during this stage of structural behavior. In displacement control, one of the displacement components is prescribed and the load factor is then unknown. Therefore, the load factor is one of the variables whose values are computed by the analysis. In using this displacement control approach, it is crucial to use a displacement component that continues to increase beyond the limit load. It should be noted also that displacement control results in an asymmetric tangent stiffness matrix \mathbf{K}_T .

In some cases, all displacement components tend to increase. It is then difficult to apply displacement control. Arc length control can be used even in such cases. Arc length control is in fact the most versatile approach to tracing the equilibrium path.

There is no single method of arc length control; rather, there are several variations. In general, in addition to Eq.(C4.1.3), another equation is introduced to control the distance between two points on the equilibrium path. An example of this type of equation is the following:

$$\Delta S = \sum_{i=1}^n \alpha_i (U_i - \bar{U}_i)^2 + b(\alpha - \bar{\alpha})^2 \quad (\text{C4.1.6})$$

where the quantity with the over-bar is the known value of a point on the equilibrium path, n is the number of displacement components, and α_i b are the coefficients that adjust the values of the different kinds of variable. The value that needs to be specified is ΔS , then all the displacement components and the load factor are computed. Compared with the other two control approaches, therefore, the number of unknown variables is one greater. Since finite element analysis involves

so many unknowns, this increase of one in the number of unknowns is not a problem at all. The combination of Eqs.(C4.1.3) and (C4.1.6) inevitably leads to an asymmetric coefficient matrix for the linearized simultaneous equations of the Newton-Raphson method. One very powerful and popular technique, the skyline method, circumvents the numerical problems associated with this asymmetry without much difficulty.

Buckling Analysis

Theoretically, buckling is a phenomenon at a point on the equilibrium path where multiple branches of the equilibrium path are possible. The value of the buckling load and the associated buckling mode are usually obtained by so-called eigenvalue analysis. However, because of initial imperfections in an actual structure, the problem is not necessarily one of branching. The load-carrying capacity of the structure may be evaluated by tracing the equilibrium path even when buckling is the major phenomenon and controls the load-carrying capacity of the structure. Even when analysis is carried out this way, however, eigenvalue analysis is usually conducted to obtain the mode of the initial imperfection.

Ignoring the deformation before buckling and deriving the stiffness matrix including the effect of finite displacement, the following stiffness equation is obtained:

$$\alpha \mathbf{F}_0 = (\mathbf{K}_E + \alpha \mathbf{K}_G(\mathbf{N}_0))\mathbf{U} \quad (\text{C4.1.7})$$

where \mathbf{K}_E is the stiffness matrix derived from small-displacement theory, \mathbf{K}_G is the geometric matrix, \mathbf{N}_0 is the internal force vector in the initial state due to base load vector \mathbf{F}_0 , and α is the load factor. Structural analysis may also be carried out using this stiffness equation, a process that is called linearized finite displacement analysis.

From Eq.(C4.1.7), the condition for the occurrence of buckling can be expressed as

$$|(\mathbf{K}_E + \alpha \mathbf{K}_G(\mathbf{N}_0))| = 0 \quad (\text{C4.1.8})$$

Solving Eq.(C4.1.8) is what is known as eigenvalue analysis. In equilibrium path tracing analysis, eigenvalue analysis is sometimes also conducted, using the tangent stiffness matrix instead of the stiffness matrix associated with the initial state, so as to find branching points and limit points. Since such eigenvalue analysis includes the effect of deformation, this is something of a nonlinear approach to analysis. This class of analysis is therefore called nonlinear buckling analysis and is distinguished from linear buckling analysis based on Eq.(C4.1.8).

By solving Eq.(C4.1.8), the load factor at the point of buckling is obtained and the buckling load is evaluated as $\alpha_{cr}\mathbf{F}_0$. This is the load at which the branching of the equilibrium path would take place if it were to occur. Otherwise, it is the limit load. Eq.(C4.1.7) yields the eigen vector \mathbf{U} for eigenvalue α_{cr} as well. The eigen vector is nothing but the buckling mode, which is often treated as the geometrical initial imperfection (the initial displacement mode) required in equilibrium path tracing analysis. The magnitude of the initial displacement is usually determined by giving it a maximum value equal to the tolerance specified in the design codes.

For the sake of simplicity, the load-carrying capacity of a member is computed using the concept of the effective length. In short, the effective length ℓ_{cr} is evaluated by the following equation:

$$\ell_{cr} = \sqrt{\frac{\pi^2 EI}{\alpha_{cr} N_0}} \quad (\text{C4.1.9})$$

where, N_0 is the axial force induced in the initial state by base load vector F_0 . Caution must be used in this evaluation since the effective length of a member with a small axial force would be

very large.

Constitutive Laws:

The equations governing structural behavior consist of three sets of equations: the equilibrium equations, the strain-displacement relationships, and the stress-strain relationships. The stress-strain relationships are also called the constitutive laws or the constitutive model. Of these three equation sets, the first two can be defined solely by rigorous mathematics. On the other hand, the stress-strain relationships depend on the actual materials. They need be constructed using experimental data obtained for the material. Consequently, the stress-strain relationships are inevitably approximations, a fact that directly influences the accuracy of the analysis.

Steel exhibits a linear relationship between stress and strain up to a certain stress level (the yield stress) and this linear relationship holds good regardless of whether the stress increases or decreases. Beyond the yield stress, the relationship becomes nonlinear and the material behavior during stress relaxation may be completely different from that during the increase in stress. This class of material behavior is modeled by plasticity theory. Many plasticity models have been proposed for various materials. Specifically, the model for steel has been constructed using the second invariant of the deviatoric stress, J_2 . This class of plasticity model for steel is therefore often called the Mises (or von Mises) model or the J_2 model.

In the analysis of ultimate strength, material behavior beyond the plateau and into the strain-hardening region may need to be included. In such a case, a hardening model must be included in the plasticity model. The isotropic hardening model, the kinematic hardening model, and the combined hardening model (a combination of the two previous models) are the classic methods and are well-known. Under monotonous loading conditions, there is little difference between these hardening models and any of them can be used. Under cyclic loading, which is often considered in conjunction with seismic design, the kinematic hardening model is usually employed in practice. It must be noted, however, that more sophisticated hardening models that can simulate actual material behavior observed in experiments under cyclic loading have been developed since the Hyogoken-Nanbu Earthquake.

The material behavior of concrete is completely different in compression and tension. Concrete consists of various small regions of different materials, the sizes of which are not necessarily insignificant, so it is not as homogeneous as steel. However, under compression, cracks occur in a rather distributed manner so its behavior under compression is generally modeled by assuming the material is a continuum. Plasticity models have been proposed for concrete to describe its mechanical behavior. Unlike steel, the material behavior of concrete is found to be dependent on the hydraulic axis. Therefore, instead of the Mises model and the Tresca model, in which the yield surfaces are parallel to the hydraulic axis in the principal stress space, the Drucker-Prager model and the Mohr-Coulomb model are usually used, since their yield surfaces slope with respect to the hydraulic axis.

In tension, explicit cracks (discontinuous surfaces) appear and deformation becomes localized. In general, while the finite element method is good for the analysis of continua, its application to problems that include discontinuities presents some difficulties. Basically, cracks are dealt with by one of two approaches: the discrete model, which simulates cracks by separating the nodes along the crack, and the smeared model, in which cracks are simulated by changing the material stiffness. Neither is much superior to the other; the discrete model tends to restrict crack growth according to the layout of the finite elements while the smeared model has difficulty in dealing with stress changes due to the modification of material constants. In the latter, the objectivity of the numerical results can take place unless the element size is taken into consideration when material constants are modified to simulate a crack.

Finite Element Mesh

When using the finite element method, the structure under consideration is divided into small regions (elements) and the deformation of each element is expressed using rather simple functions. The finite element method is nothing but an approximation technique based on discretization. Consequently, it must be noted that the finite element method inevitably involves discretization errors and that the element size must be sufficiently small to obtain satisfactory results.

In linear structural analysis, it has been shown that errors in computing displacement are proportional to the square of the element size while errors in computing stress and strain are proportional to the element size. In parts of a structure where the stress gradient is large, such as in the vicinity of stress concentrations, it is necessary to make the mesh finer than in the other areas. However, it is not easy to determine the appropriate mesh size and quantify the accuracy of the numerical results obtained.

4.2 Structural Analysis Factor

- (1) The value of the structural analysis factor, γ_a , shall be decided by taking account of various uncertainties, such as those involved in the structural analysis method and the structural model.
- (2) In general, the structural analysis factor, γ_a , may be set to 1.0 in the case of linear analysis.
- (3) In the case of nonlinear analysis, the relevance of the analysis method shall be verified first and then an appropriate value of structural analysis factor, γ_a , decided.

【Commentary】

The structural analysis factor is a partial factor that takes account of uncertainties in evaluating structural performance under the design loads

Although nonlinear analysis may be most appropriate for computing the ultimate limit state, in practice it cannot be used for all practical designs. Instead, linear analysis tends to be employed in actual design. Since linear analysis has been used to design a great many structures over many years, a structural analysis factor γ_a of 1.0 can be assumed for linear analysis.

In nonlinear analysis, the value of the structural analysis factor, γ_a , has to be set according to an adequate examination of theoretical relevancy, the applicability of the numerical method used, and so on. A value of 1.0 may be acceptable when the relevancy and accuracy of the nonlinear analysis method used are both found satisfactory.

Section 6.1 of Standard Specifications for Railway Structures (Steel-Concrete Composite Structures) [Railway Technical Research Institute, 2000] states that for the ordinary structures where linear analysis gives satisfactory results, a structural analysis factor, γ_a , of 1.0 can be assumed except when analyzing the lifting of girder bridges, for which a value of 1.1 is required. It also states that linear analysis is not suitable for long-span arch bridges and cable-stayed bridges. A linearized elastic finite displacement that includes the effect of geometrical nonlinearity is required. Since this analysis is reliable in accuracy, the structural analysis factor, γ_a , can be set equal to 1.0.

In the verification of the fatigue limit state, if data for a similar structure elsewhere confirms that the computed stress is smaller than the stress acting in the actual structure, the structural analysis factor, γ_a , may be reduced by the ratio of the actual stress to the computed stress.

Section 6.1 of Standard Specifications for Railway Structures (Steel-Concrete Composite Structures) states that a structural analysis factor, γ_a , of 0.85 can be used for verification of the fatigue limit state if the influence of the number of load repetitions is taken into consideration. This is based on data for the ratio of actual stress to computed stress, the maximum value of which is about 0.75. The value of

0.85 is considerably smaller, as the standard structural analysis factor, γ_a , for the ultimate limit state, the service limit state and the fatigue limit state based on the fatigue limit is 1.0.

In Fatigue Design Guideline for Steel Structures [Japanese Society of Steel Construction, 1993], Subsection 5.2.3 states that the value of the modification factor α , which is equivalent to the structural analysis factor used here, plays the role of adjusting the difference between computed stress and actual stress. The appropriate value is to be determined from data such as measurements of similar structures or from model experiments. The guideline provides an example of a verification in which a value of 0.85 is used following the Standard Specifications for Railway Structures (Steel-Concrete Composite Structures) [Railway Technical Research Institute, 2000].

References in Chapter 4

- Japanese Society of Steel Construction (1993) : Fatigue Design Guideline for Steel Structures and Commentaries.
- Railway Technical Research Institute (2000) : Design Standards for Railway Structures and Commentary, Steel and Composite Structures .
- Japan Road Association (2002) : Fatigue Design Guideline for Steel Highway Bridges.
- Japan Society of Civil Engineers (2005) : Buckling Design Guidelines, Ver.2 [2005 Version].
- ISO (1998) : ISO2394 International Standard, General Principles on Reliability for Structures .

Chapter 5 Structural Member Resistance

5.1 General

- (1) The design resistance of structural members, as used in the verifications specified in Chapters 6~10, shall be obtained by dividing the characteristic value of member resistance by the material partial factor.²
- (2) The characteristic values of member resistance shall be determined using the characteristic values of material strength.

【Commentary】

Most existing design specifications recommend using the minimum yield strength of the steel material as the design material strength. The minimum yield strengths of steel materials are provided by JIS based on tensile material tests on relatively small specimens under a limited range of strain rates. The variance of yields strength within a rolled steel plate is not significant, but it is not negligible in steel sections. Further, the yield strength depends on the test method such that the higher the strain rate is, the higher the obtained yield strength. Yet the static yield strength should not be lower than the minimum yield strength. Taking into account all of these contributing factors, this design code specifies the resistance of members in terms of the design material strength, which is the characteristic value of material strength as shown in section 3.4.2 divided by the partial factor of the material. Hereafter, as a general rule, the term "resistance" is used for the stress resultant and "strength" is used for the stress. The dimensionless (normalized) resistance of members will generally be represented by the resistance corresponding to the characteristic value: the influence on resistance of changes in sectional modulus will be taken into account in the member partial factor.

5.2 Partial Factor for Uncertainty in Resistance

The partial factor for uncertainty in resistance (structural member factor) shall be determined in accordance with the formulas for calculating member resistance, while also taking into consideration uncertainty in the calculation method, the influence of member size variance, and the importance of the member (the influence of a member reaching the limit state on the structure as a whole).

【Commentary】

Table C5.2.1 lists the standard partial factors for members. The factor depends on whether the characteristic value of resistance is set to the mean or the minimum. In general, its value is set as the characteristic value of resistance corresponding to the appropriate fractile value (for example 5%).

Table C5.2.1 Standard Partial Factor for Members

	Safety	Service	Durability
Partial factor for members, γ_b	1.1~1.3	1.0	1.0~1.1

In order to obtain a similar member resistance to that calculated using the resistance formulae in

Part A of the Design Code for Steel Structures [JSCE, 1997a], the value for safety in Table C5.2.2 can be used as the partial factor for members in the various resistance formulae given in Section 5.3.

Table C5.2.2 Partial Factor for Members when Using Resistance Formulae in Section 5.3

Partial factor for members, γ_b		
Tensile Resistance in Axial Direction Eq.(5.3.1) or (5.3.2)	1.00	
Compressive Resistance in Axial Direction Eq.(C5.3.1)	Group 1 (Ref.Table C5.3.2)	1.04
	Groups 2 and 3 (Ref.Table C5.3.2)	1.08
Bending Resistance Eq.(C5.3.2)	Rolled I or H sections, Box sections, -shape sections	1.04
	Fabricated I or H sections	1.08
Shear Resistance of Webs Eq.(C5.3.22), (C5.3.27)	1.00	
Local Buckling Strength Eq.(C5.3.35)~(C5.3.59)	Eq.(C5.3.35)~(C5.3.38),(C5.3.59))	1.10
	Eq.(C5.3.43)	1.14
	Eq.(C5.3.57)	1.01
Resistance of Steel Pipes Eq.(C5.4.1)~(C5.4.5)	1.08	
Resistance of Cables Eq.(5.5.1)	Table C5.2.3	

Though these values are basically the inverse of the resistance factors given in Part A of the Design Code for Steel Structures [JSCE, 1997a], the reduction in the region where the slenderness ratio parameter is smaller than $\bar{\lambda}_0$ is not considered here for simplification.

The partial factors for cable members are defined by applying the multiplying factor for the ultimate load in [JRA, 2002] to the design material strength derived from the 0.7% total elongation resistance. For reference, [HSBA, 1980] employs a member partial factor of 1.0 because the tensile strength characteristics of cables have low variance, and so are highly reliable.

Table C5.2.3 Partial Factor for Cable Members

Types of Structural Cable Material	Partial factor for members, γ_b	
Structural Strand Rope (St.R)	IWSC Type	1.18
	CFRC Type	1.18
Structural Spiral Rope (Sp.R))		1.11
Structural Locked Coil Rope (L.C.R)		1.11
Parallel Strand Wire Cable (P.W.S)		1.05
Parallel Wire Cable (P.W.C)		1.05
Pseudo Parallel Wire Cable (S.P.W.C)		1.05

5.3 Steel Member Resistance

5.3.1 Tensile resistance

The tensile resistance of structural members shall be taken as the smaller of the values calculated by Equations (5.3.1) and (5.3.2).

$$N_{rd} = \frac{A_g f_{yd}}{\gamma_b} \quad (5.3.1)$$

$$N_{rd} = \frac{A_n f_{ud}}{\gamma_b} \quad (5.3.2)$$

where, N_{rd} : design tensile resistance of the member
 A_g : gross area of the cross section to be verified
 A_n : net area of the cross section to be verified
 f_{yd} : design yield strength
 f_{ud} : design tensile strength
 γ_b : structural member factor

【 Commentary 】

The influence of variations in sectional modulus, such as in cross-sectional area and plate thickness, which affect the axial resistance of tension members, is considered in the safety factor (member partial factor), thus it is not included in the characteristic value of member resistance. For example, when steel plates are specified and supplied with a strict plate thickness tolerance, a responsible engineer can reduce the safety factor and include the influence in the response value described in Chapter 6.

5.3.2 Compressive resistance

The compressive resistance of steel structural members in the axial direction shall be taken as the smaller of the resistance value for the strong axis and the weak axis calculated on the basis of the buckling curve in consideration of factors such as structural member imperfections, eccentric loading, residual stress, and variance in the yield strength in the cross section as well as the local buckling strength of plate elements constituting the member.

【 Commentary 】

The design compressive resistance in the axial direction can be calculated in consideration of local buckling of structural members using, for example, Eq.(C5.3.1). Three types of buckling curves are defined for different groups of cross sections and manufacturing processes by using the ECCS curves as the buckling curves of columns based on Ref.[SGST, 1980]. The compressive resistance of members based on these curves includes the influence of variance in sectional modulus according to Ref.[JSCE, 1994]. The definitions given in Chapter 11 can be utilized for the effective buckling length of frame members.

$$N_{rd} = \begin{cases} \frac{A_g Q_c f_{yd}}{\gamma_b} & (\bar{\lambda} \leq \bar{\lambda}_0) \\ \frac{A_g Q_c f_{yd}}{2\bar{\lambda}^2} \frac{(\beta - \sqrt{\beta^2 - 4\bar{\lambda}^2})}{\gamma_b} & (\bar{\lambda} > \bar{\lambda}_0) \end{cases} \quad (\text{C5.3.1})$$

$$\beta = 1 + \alpha(\bar{\lambda} - \bar{\lambda}_0) + \bar{\lambda}^2$$

where , N_{rd} : Design compressive resistance in axial direction of member

A_g : Gross area of cross section to be verified

f_{yd} : Design yield strength

$\bar{\lambda}$: Slenderness ratio ,

$$\bar{\lambda} = \frac{1}{\pi} \sqrt{\frac{Q_c f_{yk} \ell}{E r}}$$

ℓ : Effective buckling length of member; standard effective lengths are given in Table C5.3.1 for boundary conditions at each end of a member based on member length L and with pin connections at each end. When restriction is not sufficient, the effective buckling length can be raised to a reasonable value.

r : Radius of gyration of total cross section to be verified

E : Young's modulus of steel

Table C5.3.1 Effective Buckling Length of Members ℓ

If the buckled waveform is shaped like the dotted line			1	2	3	4	5	6
Theoretical value of effective buckling length			$0.5L$	$0.7L$	L	L	$2L$	$2L$
Support conditions	Upper end	Condition for rotation	Fixed	Free	Fixed	Free	Free	Fixed
		Condition for horizontal displacement	Fixed	Fixed	Free	Fixed	Free	Free
	Lower end	Condition for rotation	Fixed	Fixed	Fixed	Free	Fixed	Free
		Condition for horizontal displacement	Fixed	Fixed	Fixed	Fixed	Fixed	Fixed

Table C5.3.2 Categorization of Cross Section of Steel Columns

Section Type	Coordinate axes	Group	α	$\bar{\lambda}_0$
Rolled box sections 	Both axes included	1	0.089	0.2
Welded box sections 	Both axes included	1	0.089	0.2
Rolled I-sections 	$t \leq 40$ Both axes included	1	0.089	0.2
Welded I-sections 	$t \leq 40$ Both axes included	2	0.224	0.2
	$t > 40$ Both axes included	3	0.432	0.2
	Both axes included	2	0.224	0.2
Others	Both axes included	3	0.432	0.2

$\bar{\lambda}_0$: Limit slenderness ratio given in Table C5.3.2 according to the sectional shape and manufacturing process

α : Initial imperfection coefficient given in Table C5.3.2

Q_c : Non-dimensional strength of short column that suffers local buckling

$$Q_c = \frac{\sum(\sigma_{rd}A_{fc})}{A_g f_{yd}}$$

σ_{rd} : Local buckling strength of plate supported on both edges, plate supported on one edge, stiffened plate or steel pipe obtained from Eqs.(C5.3.35), (C5.3.38), (C5.3.43), (C5.4.2), respectively

A_{fc} : Cross-sectional area of plate element or steel pipe whose σ_{rd} has been calculated

\sum : Summation of plate elements that constitute the cross-sectional area

5.3.3 Bending resistance

5.3.3.1 Classification of cross section

Structural members are classified as follows according to the maximum width-thickness ratio of the sectional element subject to bending or combined compression and bending (that is, the member's resistance to local buckling):

- (1) Compact section: sections that may develop a plastic moment resistance
- (2) Non-compact section: sections in which the stress in the extreme compression fiber of the steel, assuming an elastic distribution of stresses, may reach the yield strength, but local buckling is likely to prevent development of a plastic moment resistance
- (3) Slender section: sections in which local buckling will occur before the yield stress is reached in one or more parts of the cross section.

【 Commentary 】

Eurocode 3 [CEN, 2003] categorizes cross sections into the following four classes.

- Class 1 : cross-sections are those which can form a plastic hinge with the rotation capacity required from plastic analysis without reduction of the resistance.
- Class 2 : cross-sections are those which can develop their plastic moment resistance, but have limited rotation capacity because of local buckling.
- Class 3 : cross-sections are those in which the stress in the extreme compression fibre of the steel member assuming an elastic distribution of stresses can reach the yield strength, but local buckling is liable to prevent development of the plastic moment resistance.
- Class 4 : cross-sections are those in which local buckling will occur before the attainment of yield stress in one or more parts of the cross-section.

In this code, there is in general no redistribution of moments because response values are basically computed by elastic analysis. Thus, sections categorized as Class 1 and Class 2 according to Eurocode 3 are defined as compact sections that fully develop a plastic moment. This cross-section categorization is also used in [AASHTO (1998)].

Each design code has different conditions for the categorization of member cross sections. For example, the formulae defining the conditions for compact sections consisting of steel I-beam flanges and webs in compression under bending are compared in Table C5.3.3. On the whole, the ISO (1997)

Table C5.3.3 Conditions of Compact Sections for Steel I-Beam

(a) Compression flange						(b) Web				
$\frac{b}{t} \leq p \sqrt{\frac{E}{f_y}}$ (where, b : width of outstanding part of flange, f_y : Characteristic value of yield stress.)						$\frac{\alpha b}{t} \leq p \sqrt{\frac{E}{f_y}}$ (where, α : Ratio of compression part in web, b : web depth, t : web thickness.)				
	AASHTO	Eurocode	ISO	Part A	Part B	AASHTO	Eurocode	ISO	Part A	Part B
p	0.382	0.343	0.37	0.310	0.309	1.88	1.42	1.9	1.28	1.13

and AASHTO codes are similar and have easier conditions, while JSCE Part A and B [JSCE, 1997a, b] provide for considerably strict conditions. In general, the cross section categorization given by the ISO code is to be used, as shown in Table C5.3.4.

Table C5.3.4 Maximum Width-Thickness Ratio of Cross-Sectional Element under Compression and/or Bending. [ISO , 1997]

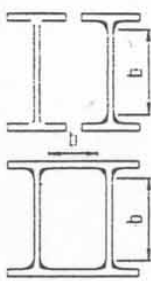
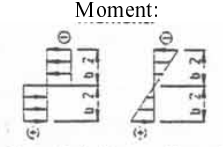
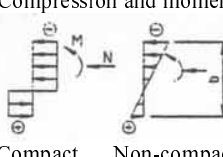
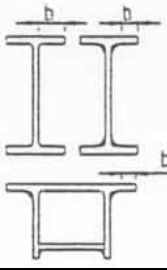
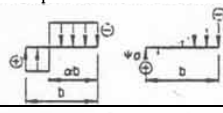
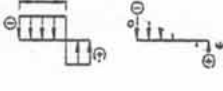
Cross section element	Stress distribution in the element	Maximum b/t Ratio	
		Compact	Non-compact
Webs of I-sections, Webs or flanges of welded box sections 	Moment:  Compact Non-compact	$3.8 \sqrt{\frac{E}{f_y}}$	$4.2 \sqrt{\frac{E}{f_y}}$
	Compression and moment  Compact Non-compact	$3.8K_1 \sqrt{\frac{E}{f_y}}$	$4.2K_2 \sqrt{\frac{E}{f_y}}$
Flanges of I-sections, Free flanges of welded box sections 	Compression or strong axis moment	$0.37 \sqrt{\frac{E}{f_y}}$	$0.45 \sqrt{\frac{E}{f_y}}$
	Compression and moment  Compact Non-compact	$\frac{0.37}{\alpha\sqrt{\alpha}} \sqrt{\frac{E}{f_y}}$	$0.69K_3 \sqrt{\frac{E}{f_y}}$
	 Compact Non-compact	$\frac{0.37}{\alpha\sqrt{\alpha}} \sqrt{\frac{E}{f_y}}$	$0.69K_4 \sqrt{\frac{E}{f_y}}$
$K_1 = 1 - 0.63N / N_p, \quad K_2 = 1 - 0.67N / N_p, \quad K_3 = \sqrt{0.425 - 9.1(\psi + 1) + 10.4(\psi + 1)^2},$ $K_4 = \sqrt{0.57 + 0.2\psi + 0.07\psi^2}$ <p>N/N_p refers to the fully cross section for doubly symmetric sections and ψ is positive as indicated above.</p>			

5.3.3.2 Bending resistance

The bending resistance of steel structural members shall be determined based on the nominal bending resistance corresponding to the classification of cross section, taking into account the influence of initial deflection and residual stress as well as elastic lateral-torsional buckling.

【 Commentary 】

The bending strength of steel structural members excluding steel pipes should be determined using Eq.(C5.3.2). However, if the compressive flange is directly secured to a concrete slab or similar, $\bar{\lambda}_b$

must always be taken as less than $\bar{\lambda}_{b0}$.

$$M_{rd} = \begin{cases} \frac{M_n}{\gamma_b} & (\bar{\lambda}_b \leq \bar{\lambda}_{b0}) \\ \frac{M_n}{2\bar{\lambda}_b^2} \frac{(\beta_b - \sqrt{\beta_b^2 - 4\bar{\lambda}_b^2})}{\gamma_b} & (\bar{\lambda}_b > \bar{\lambda}_{b0}) \end{cases} \quad (C5.3.2)$$

$$\beta_b = 1 + \alpha_b(\bar{\lambda}_b - \bar{\lambda}_{b0}) + \bar{\lambda}_b^2$$

Where , M_{rd} : Bending strength of beam members with respect to the strong axis
 M_n : Standard bending strength of beam section

$$\text{i) Compact Section} \quad M_n = f_{yd}Z \quad (C5.3.3)$$

$$\text{ii) Non-Compact Section} \quad M_n = f_{yd}W \quad (C5.3.4)$$

$$\text{iii) Slender Section} \quad M_n = f_{yd}W_{eff} \quad (C5.3.5)$$

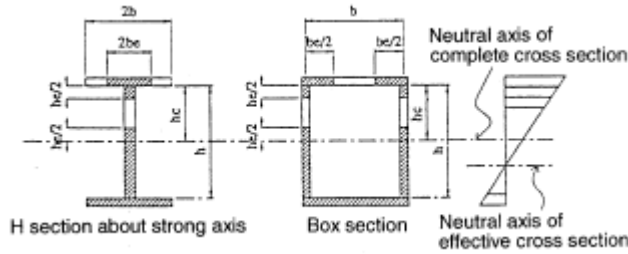

Fig.C5.3.1 Effective Sections of Beams

f_{yd} : Design strength of material

Z : Plastic section modulus

W : Elastic sectional modulus of compression flange

W_{eff} : Effective sectional modulus of compression flange computed considering the effective width due to local buckling. The effective width should be taken as shown in Fig.C5.3.1 .

Effective width of compression flange:

$$\text{Plate supported at all edges:} \quad \frac{b_e}{b} = \left(\frac{0.7}{R_f} \right)^{0.80} \quad (C5.3.6)$$

$$\text{Plate supported at one edge:} \quad \frac{b_e}{b} = \left(\frac{0.7}{R_f} \right)^{0.64} \quad (C5.3.7)$$

Effective width of web

$$\frac{h_e}{h_c} = \left(\frac{1.0}{R_w} \right)^{0.80} \quad (C5.3.8)$$

$\bar{\lambda}_{b0}$: Limit slenderness ratio of beam (Table C5.3.5)

α_b : Initial imperfection coefficient (Table C5.3.5)

$\bar{\lambda}_b$: Slenderness ratio of beam

$$\bar{\lambda}_b = \sqrt{\frac{M_{\bar{n}}}{M_E}} \quad (M_{\bar{n}} \text{ is given by Eq.(C5.3.10) , } M_E \text{ is given by Eq.(C5.3.12).)} \quad (C5.3.9)$$

Table C5.3.5 Parameters in Bending Resistance Formula for Beams

	α_b	$\bar{\lambda}_{b0}$
Rolled I or H sections box sections, π -shape sections	0.15	0.40
Fabricated I or H sections	0.25	0.40

$M_{\bar{n}}$: Characteristic value of standard bending resistance of beam section given by Eq.(C5.3.10), (standard value)

$$M_{\bar{n}} = M_n \frac{f_{yk}}{f_{yd}} \quad (\text{C5.3.10})$$

f_{yk} : Characteristic value of material strength (standard value)

R_f, R_w : Width-thickness ratio of flange and web, respectively

$$R = \frac{1}{\pi} \sqrt{\frac{12(1-\nu^2)}{k}} \sqrt{\frac{f_{yk}}{E}} \frac{b}{t} = \frac{1.05}{\sqrt{k}} \sqrt{\frac{f_{yk}}{E}} \frac{b}{t} \quad (\text{C5.3.11})$$

k : Buckling coefficient

Flanges supported at all edges	$k = 4.0$
Flanges supported at one edge	$k = 0.425$
Webs	$k = 23.9$

b : Total width of plate (Refer to Fig.C5.3.1. For webs, replace with h)

t : Plate thickness

Z : Plastic sectional modulus

E : Young's modulus of steel

ν : Poisson's ratio

M_E : Elastic transverse torsional buckling moment of simply supported beam. When the loading condition is different from this, eigenvalue analysis for elastic buckling may be used to obtain the transverse torsional buckling moment.

$$M_E = \frac{C_{b1} \pi^2 E I_y}{\ell^2} \left[C_{b2} h_t + C_{b3} \beta_z + \sqrt{(C_{b2} h_t + C_{b3} \beta_z)^2 + \frac{1}{\gamma} \frac{I_w}{I_y} \left(1 + \frac{\ell^2 G J}{\pi^2 E I_w} \right)} \right] \quad (\text{C5.3.12})$$

$$\gamma = 1 - I_y / I_x$$

Where, I_y, I_z : Moment of inertia with respect to the weak and strong axes, respectively

J : St. Venant's torsion constant

I_w : Warping torsion constant

ℓ : Length of simply supported beam for out-of plane deformation (cm). Generally, this length may be taken as the distance between the fixed points of the compression flange. However, if the constraints at both ends are considered adequate, then this value may be reduced to a rational value .

C_{b1} : Equivalent moment factor (Refer to Table C5.3.6 for intermediate loading)

$$C_{b1} = \frac{1.0}{0.6 + 0.4\beta} \leq 2.5 \quad \beta = \frac{M_2}{M_1} \quad (\text{C5.3.13})$$

Table C5.3.6 Various Parameters of Beams Subject to Intermediate Loading

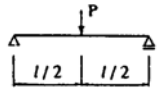
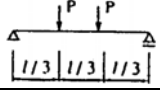
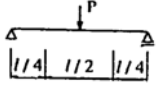
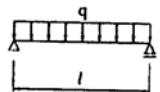
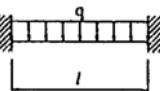
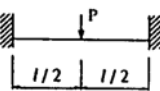
Loading condition	M_{max}	C_{b1}	C_{b2}	C_{b3}
	$\frac{Pl}{4}$	1.365	0.553	0.406
	$\frac{Pl}{3}$	1.096	0.500	0.480
	$\frac{Pl}{4}$	1.040	0.422	0.570
	$\frac{ql^2}{8}$	1.132	0.459	0.525
	$\frac{ql^2}{24}$	1.286	1.563	0.782
	$\frac{Pl}{8}$	1.736	1.406	2.767

M_1, M_2 : Bending moments at each end of member, where $M_1 \geq M_2$. The sign of the bending moment is to be taken as positive when compressive stress occurs in the flange.

h_t : Distance between the position at which load acts (height) and the shear center. (The sign shall be taken as positive when the position at which the load acts is closer to the tension side in bending than the shear center)

C_{b2} : Coefficient for correcting the effect of the position at which the load acts according to the loading condition (Refer to Table C5.3.6)

β_z : Coefficient expressing the asymmetry of the cross section

$$\beta_z = \int_A \frac{Y(Z^2 + Y^2)}{2I_z} dA - Y_z \quad (\text{C5.3.14})$$

Y_z : Distance from the center of gravity to the shear center

C_{b3} : Coefficient for correcting the effect of the asymmetric cross section according to the loading condition (Refer to Table C5.3.6)

The above descriptions are for the characteristic values of bending resistance of members with box or H sections. The bending resistance of H sections about weak axis is out of scope because structural members are designed as they are subjected to bending only about strong axis in real structures. In addition, beams for which the influence of shear force on web capacity must be considered are also out of scope although the shear force as well as bending moment applies to general beams.

The reduction of bending resistance of beams due to lateral-torsional buckling is given by Perry-Robertson type strength curve to keep consistent with columns. The curves for rolled and welded H sections are different. In general, lateral-torsional buckling is difficult to occur for box and π

section beams. However, it can occur for considerably deep beams with these sections. The same lateral-torsional buckling strength curve as the rolled H sections is tentatively used here for box and section beams. As the reference for readers, the slenderness ratio of box sections taking the yield moment as the standard bending resistance is shown below.

$$t_f = pt, \quad I_z = \frac{th^2}{6}(3pb + h), \quad I_y = \frac{t}{6}(3hb^2 + b^3),$$

$$I_w = \frac{tb^2h^2(ph - b)^2(h + pb)}{24(ph + b)}, \quad J = \frac{2b^2h^2pt}{ph + b}, \quad q = \frac{h}{b}$$

The lateral-torsional buckling moment of a simply supported beam in uniform bending moment is given by Eq.(C5.3.15).

$$M_E = \frac{\pi}{\ell} \sqrt{\frac{1}{\gamma} EI_y GJ \left(1 + \frac{\pi^2 EI_w}{\ell^2 GJ} \right)} \quad (\text{C5.3.15})$$

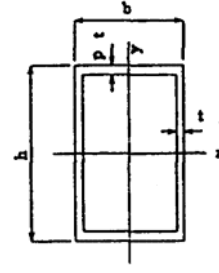

Fig.C5.3.2 Dimension of box-section

Where,

$$\gamma = 1 - \frac{I_y}{I_z} \quad (\text{C5.3.16})$$

The torsion constant ratio κ^2 is ,

$$\kappa^2 = \frac{\pi^2 EI_w}{\ell^2 GJ} = \frac{\pi^2 E}{48 G} \left(\frac{b}{\ell} \right)^2 \frac{(pq - 1)^2 (p + q)}{p(pq + 1)} \quad (\text{C5.3.17})$$

where,

$$\left(\frac{b(pq - 1)}{\ell} \right)^2 = \left(\frac{ph - b}{\ell} \right)^2 \quad (\text{C5.3.18})$$

When the member length ℓ is more than 2~3 times of $(ph - b)$, it can be thought that $k^2 \ll 1$.

Therefore, M_E is expressed as follows.

$$M_E = \frac{\pi}{\ell} \sqrt{\frac{EI_y GJ}{\gamma}} \quad (\text{C5.3.19})$$

Taking the yield moment as the standard bending resistance of the section,

$$M_n = f_{yd} W = \frac{2f_{yd} I_z}{h} \quad (\text{C5.3.20})$$

Thus, the slenderness ratio can be obtained by

$$\bar{\lambda}^2 = \frac{M_n}{M_E} = \frac{2f_{yd} I_z}{h} \frac{\ell}{\pi} \sqrt{\frac{\gamma}{EI_y GJ}} \quad (\text{C5.3.21})$$

and

$$\bar{\lambda}^2 \frac{E}{f_{yd}} \frac{b}{\ell} = 0.2963 \sqrt{\frac{(pq + 1)(3p + q)^2}{(p + 3q)} \left(1 - \frac{3q + p}{q^2(3p + q)} \right)} \quad (\text{C5.3.22})$$

Fig.C5.3.3 is the graph of Eq.(C5.3.22).

Assuming a box section beam with $p = 1.0$, $\ell/b = 10$ and $F = 235\text{N/mm}^2$ (JIS-SS400 steel), λ becomes more than 1.11. So, the reduction of bending resistance due to lateral-torsional buckling occurs when $q = h/b > 3.2$, otherwise it does not have to be considered.

Short beams sufficiently supported in lateral direction can reach bending resistances of the section (M_p or M_y), whereas the bending resistance of long beams is determined by elastic lateral-torsional

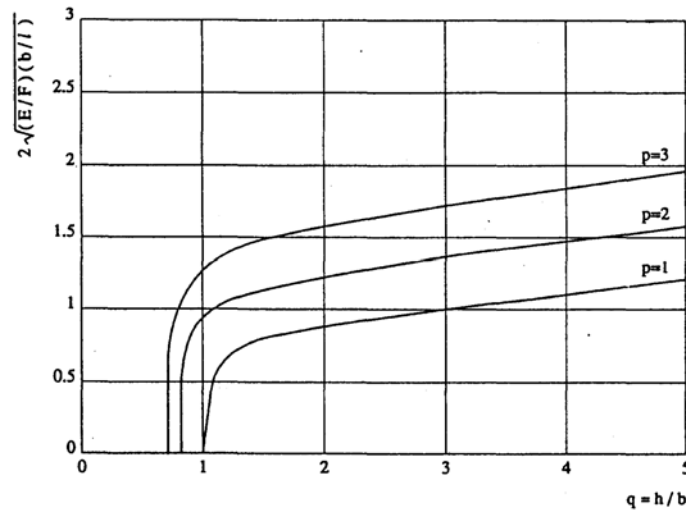

Fig.C5.3.3 Relationship between aspect ratio and slenderness ratio for box sections

buckling moment. Consequently, $\sqrt{M_n/M_E}$ is used as slenderness ratio to lateral-torsional buckling corresponding to the bending resistance of the section M_n . Influence of loading conditions and boundary conditions is taken into account in the calculation of elastic lateral-torsional buckling moment M_E . Eq.(C5.3.12) is obtained from theoretical solution of elastic buckling by approximating the influence of loading conditions. When the loading condition is different from this or sufficient restriction is applied to both ends, eigenvalue analysis for elastic buckling may be used to obtain the lateral-torsional buckling moment.

A coupled buckling (lateral-torsional buckling and local buckling) strength evaluation method using the effective width is adopted in this specification. There are some cases where Q-factor can be conveniently used when flanges and webs are composed of stiffened plates. For such cases, the effective width should be obtained by evaluating the resistance of the plate element as single plate, and then the bending resistance of the section should be calculated with the consideration of the shift of neutral axis (Effective Section Method).

Specifications for Highway Bridges [JRA, 2002] have the provisions based on the yield moment M_y for the welded beams with sections having relatively large width-thickness ratio. However, rolled beams with small slenderness ratio can be expected to reach fully plastic moment. Thus, the bending resistance of M_p is specified for the sections composed of plates whose slenderness ratios are smaller than the plastic limit (The first hinge method).

5.3.4 Shear resistance of web

The shear resistance of the webs shall be determined properly in consideration of factors such as the constraining effect of flange and stiffeners, initial deformation, and residual stress due to welding.

【 Commentary 】

The design shear resistance of a web can be generally determined based on shear buckling strength of a single panel under pure shear loading or based on diagonal tension field theory as described below.

(1) Based on shear buckling strength [Bleich, 1952]

$$V_{rd} = V_{cr} = \frac{\tau_{cr} t h}{\gamma_b} \quad (\text{C5.3.23})$$

where ,

$$\tau_{cr}/f_{vyd} = \begin{cases} 1.0 & (\lambda_s \leq 0.6) \\ 1 - 0.614(\lambda_s - 0.6) & (0.6 < \lambda_s \leq \sqrt{2}) \\ 1/\lambda_s^2 & (\sqrt{2} < \lambda_s) \end{cases} \quad (C5.3.24)$$

$$\lambda_s = \frac{h}{t} \sqrt{\frac{12(1-\nu^2)}{k_\tau}} \sqrt{\frac{f_{vyd}}{E}} \quad (C5.3.25)$$

$$k_\tau = \begin{cases} 4.00 + 5.34/\alpha^2 & (\alpha \leq 1) \\ 5.34 + 4.00/\alpha^2 & (\alpha > 1) \end{cases} \quad (C5.3.26)$$

where , f_{vyd} : Design shear strength
 α : Aspect ratio of web panel (= a/h)
 ν : Poisson's ratio of steel
 E : Young's modulus of steel
 h : Web height
 t : Plate thickness

(2) Based on diagonal tension field theory [JSCE, 2005]

$$V_{rd} = \frac{V_{cr} + V_t + V_f}{\gamma_b} \quad (C5.3.27)$$

$$V_t = \sigma_t h t (\sin \theta \cos \theta - \alpha_c \sin^2 \theta) \quad (C5.3.28)$$

where ,

$$\sigma_t/f_{ydw} = 1 - (\tau_{cr}/f_{vydw})^{0.6} \quad (C5.3.29)$$

f_{ydw} : Design material strength of web
 f_{vydw} : Design material shear strength of web

$$\theta = \frac{2}{3} \tan^{-1} \left(\frac{1}{\alpha} \right) \quad (C5.3.30)$$

α : Aspect ratio of web panel (= a/h)

$$\alpha_c = \alpha \{1 - (C_c - C_t)/a\} \quad (C5.3.31)$$

a : Distance between vertical stiffeners

$$\left. \begin{aligned} C_c &= \frac{2}{\sin \theta} \sqrt{\frac{M_{pfc}}{\sigma_t t}} & (0 \leq C_c \leq \frac{a}{2}) \\ C_t &= \frac{2}{\sin \theta} \sqrt{\frac{M_{pft}}{\sigma_t t}} & (0 \leq C_t \leq \frac{a}{2}) \end{aligned} \right\} \quad (C5.3.32)$$

M_{pfc} , M_{pft} : Fully plastic moment of compression flange and tension flange, respectively, given by the following Eq.(C5.3.33):

$$\left. \begin{aligned} M_{pfc} &= \frac{1}{4} f_{yc} b_{fc} t_{fc}^2 \\ M_{pft} &= \frac{1}{4} f_{yt} b_{ft} t_{ft}^2 \end{aligned} \right\} \quad (C5.3.33)$$

- $f_{ydfc}, f_{ydf t}$: Design material strength of compression flange and tension flange, respectively
 b_{fc}, b_{ft} : Width of compression flange and tension flange, respectively
 t_{fc}, t_{ft} : Plate thickness of compression flange and tension flange, respectively

$$V_f = \min \left(\frac{4M_{pfc}}{C_c}, \frac{4M_{pft}}{C_t} \right) \quad (C5.3.34)$$

However, plate girders carry shear and bending loads. V_f is generally not counted due to bending stress on the flanges.

5.3.5 Local buckling resistance

- (1) The local buckling resistance of plates supported at both ends or at one edge and of stiffened plates subject to compression shall be determined in consideration of factors such as boundary conditions and initial imperfections due to welding, including initial deformation and residual stress.
- (2) Plates supported at both ends or at one edge and stiffened plates in locations with particular ductility requirements shall be of dimensions that guarantee the required ductility.

【 Commentary 】

- (1) The local buckling strength of a plate supported at both ends and subject to uniform compression should be computed using Eq.(C5.3.35). However, this does not apply to the web plate of plate girders.

$$\sigma_{rd} = \begin{cases} \frac{f_{yd}}{\gamma_b} & (R \leq 0.70) \\ \left(\frac{0.7}{R} \right)^{0.86} \frac{f_{yd}}{\gamma_b} & (0.70 < R) \end{cases} \quad (C5.3.35)$$

where , σ_{rd} : Design local buckling strength

f_{yd} : Design material strength

R : Width-thickness ratio ,

$$R = \frac{1}{\pi} \sqrt{\frac{12(1-\nu^2)}{k}} \sqrt{\frac{f_{yk}}{E}} \frac{b}{t}$$

ν : Poisson's ratio

k : Buckling coefficient, $k = 4.0$

E : Young's modulus of steel

f_{yk} : Characteristic value of material strength (standard value)

b : Distance between fixed edges of plate (refer to Fig.C5.3.4)

t : Plate thickness

- (2) The local buckling strength of a plate supported at both ends and subject to in-plane bending should be computed using Eq.(C5.3.36). However, this does not apply to the web plate of plate girders.

$$\sigma_{rd} = \begin{cases} \frac{f_{yd}}{\gamma_b} & (R \leq 1.00) \\ \left(\frac{1}{R} \right)^{0.72} \frac{f_{yd}}{\gamma_b} & (1.00 < R) \end{cases} \quad (C5.3.36)$$

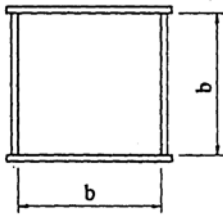

Fig.C5.3.4 Distance between the fixed edges of plate supported at both ends

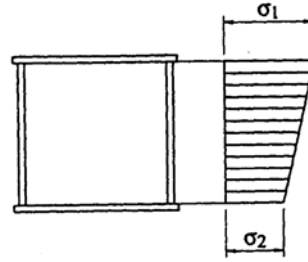
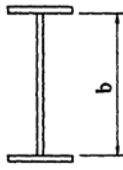

Fig.C5.3.5 Stress level at edge of plate supported at both ends

where , σ_{rd} : Design local buckling strength (refer to Fig.C5.3.5)

f_{yd} : Design material strength

R : Width-thickness ratio ,

$$R = \frac{1}{\pi} \sqrt{\frac{12(1-\nu^2)}{k}} \sqrt{\frac{f_{yk}}{E}} \frac{b}{t}$$

ν : Poisson's ratio

k : Buckling coefficient, $k = 23.9$

E : Young's modulus of steel

f_{yk} : Characteristic value of material strength (standard value)

b : Distance between fixed edges of plate (refer to Fig.C5.3.4)

t : Plate thickness

- (3) The local buckling strength of a plate supported at both ends and subject to a combination of in-plane bending and uniform compression should be computed using Eq.(C5.3.7). However, this does not apply to the web plate of plate girders.

$$\sigma_{rd} = \begin{cases} \frac{f_{yd}}{\gamma_b} & (R \leq 0.70) \\ \left(\frac{0.7}{R}\right)^{0.86} \frac{f_{yd}}{\gamma_b} & (0.70 < R) \end{cases} \quad (\text{C5.3.7})$$

where , σ_{rd} : Design local buckling strength

f_{yd} : Design material strength

R : Width-thickness ratio ,

$$R = \frac{1}{\pi} \sqrt{\frac{12(1-\nu^2)}{k}} \sqrt{\frac{f_{yk}}{E}} \frac{b}{tf}$$

ν : Poisson's ratio

k : Buckling coefficient , $k = 4.0$

E : Young's modulus of steel

f_{yk} : Characteristic value of material strength (standard value)

b : Distance between fixed edges of plate (refer to Fig.C5.3.4)

t : Plate thickness

f : Stress gradient coefficient , $f = 0.32\phi^2 + 0.08\phi + 1.00$

ϕ : Stress gradient ,

$$\phi = \frac{\sigma_1 - \sigma_2}{\sigma_1} (0 \leq \phi \leq 2)$$

σ_1, σ_2 : Stress at each edge of plate.

The sign of compressive stress is to be taken as positive. $\sigma_2 \leq \sigma_1$ (refer to Fig.C5.3.5) .

- (4) The local buckling strength of a plate supported at one edge and subject to in-plane compression

should be computed using the following Eq.(C5.3.38):

$$\sigma_{rd} = \begin{cases} \frac{f_{yd}}{\gamma_b} & (R \leq 0.70) \\ \left(\frac{0.7}{R}\right)^{0.64} \frac{f_{yd}}{\gamma_b} & (0.70 < R) \end{cases} \quad (\text{C5.3.38})$$

where , σ_{rd} : Design local buckling strength

f_{yd} : Design material strength

R : Width-thickness ratio ,

$$R = \frac{1}{\pi} \sqrt{\frac{12(1-\nu^2)}{k}} \sqrt{\frac{f_{yk}}{E}} \frac{b}{t}$$

ν : Poisson's ratio

k : Buckling coefficient , $k = 0.425$

E : Young's modulus of steel

f_{yk} : Characteristic value of material strength (standard value)

b : Distance from support point to free edge (refer to Fig.C5.3.6)

t : Plate thickness

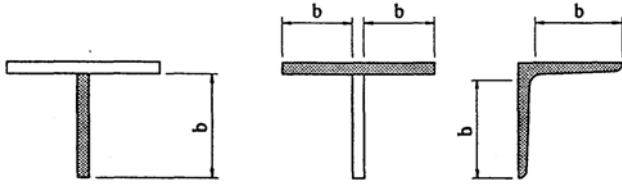

Fig.C5.3.6 Width of cantilever part of plate supported at one edge



Fig.C5.3.7 Rectangular plate subject to uniform compressive stress

The local buckling strength of a plate subject to compressive stress can be computed based on the elastic buckling stress of a rectangular plate of constant thickness subject to a uniform compressive stress, as shown in Fig.C5.3.7:

$$\sigma_E = k \frac{\pi^2 E}{12(1-\nu^2)} \left(\frac{t}{b}\right)^2 \quad (\text{C5.3.39})$$

With the base width-thickness ratio parameter:

$$R = \sqrt{\frac{f_{yk}}{\sigma_E}} = \frac{b}{\pi t} \sqrt{\frac{12(1-\nu^2)}{k}} \sqrt{\frac{f_{yk}}{E}} \quad (\text{解 5.3.40})$$

Local buckling strength is determined by evaluating the margin in resistance after elastic buckling of a plate with a large width-thickness ratio, taking into account also the reduction in local buckling strength due to residual stress and initial deflection. Here, the minimum buckling coefficient k is assumed to be $b = \infty$: Under uniform compression, a plate supported at both edges takes $k = 4.0$ and a plate supported at one edge takes $k = 0.425$.

In Eq.(C5.3.37), the stress gradient parameter f in the width-thickness ratio parameter R is multiplied by the stress gradient $\phi = 0$ buckling coefficient f when there is a stress gradient.

$$f = \sqrt{\frac{k(\phi = \phi)}{k(\phi = 0)}} \quad (\text{C5.3.41})$$

Stress gradient parameter f is given for $\phi = 0, 1, 2$ in Table C5.3.7. The definition of f is obtained, for the other ϕ , by interpolating on a quadratic parabola as follows:

$$f = 0.32\phi^2 + 0.08\phi + 1.00 \quad (\text{C5.3.42})$$

Table C5.3.7 Relationship between buckling coefficient k , stress gradient parameter f and stress gradient

Stress gradient $\phi = \frac{\sigma_1 - \sigma_2}{\sigma_1}$	$\phi = 0$	$\phi = 1$	$\phi = 2$
Buckling coefficient k	4.0	7.81	23.9
Stress gradient parameter f	1.0	1.40	2.44

- (5) The local buckling strength of a stiffened plate subject to unidirectional compression should, in principle, be computed using Eq.(C5.3.43). The stiffness and arrangement of stiffeners should be satisfied 7.3.1. Specifically, the stiffness should be larger than the required value in the Specifications for Highway Bridges [JRA, 2002], and the arrangement should be uniform interval.

$$\sigma_{rd} = N_{usp} \frac{f_{yd}}{\gamma_b} \quad (\text{C5.3.43})$$

where , σ_{rd} : Design local buckling strength
 f_{yd} : Design material strength
 N_{usp} : Standard compressive resistance of stiffened plate elements obtained from Eq.(C5.3.44)

$$N_{usp} = \frac{(n-1)\sigma_r \left(\frac{bt}{n} + h_r t_r \right) + \frac{1}{n} bt \sigma_{culp}}{bt + (n-1)h_r t_r} \quad (\text{C5.3.44})$$

where , σ_{culp} : Non-dimensional standard compressive strength of plate supported at both edges obtained from Eq.(C5.3.45)
 σ_r : Non-dimensional standard compressive strength of T-section of one longitudinal stiffener and plate panel between longitudinally stiffened members obtained from Eq.(C5.3.46)
 n : Number of panels divided by stiffeners in the longitudinal direction ($n \geq 2$)
 b : Total width of stiffened plate
 t : Thickness of plate panel

Values of σ_{culp} and σ_r can be obtained using the following equations:

$$\sigma_{culp} = \left(\frac{0.7}{R_{cp}} \right)^{0.86} \quad (< 1) \quad (\text{C5.3.45})$$

$$\sigma_r = \begin{cases} 1.0 & (\bar{\lambda}^* \leq 0.2) \\ \frac{s - \sqrt{s^2 - 4\bar{\lambda}^{*2}}}{2\bar{\lambda}^{*2}} & (\bar{\lambda}^* > 0.2) \end{cases} \quad (\text{C5.3.46})$$

in which the following notation is used:

$$s = 1 + 0.339(\bar{\lambda}^* - 0.2) + \bar{\lambda}^{*2} \quad (\text{C5.3.47})$$

$$\bar{\lambda}^* = \left(\frac{f_{yr}}{f_{yk}} \right)^{0.2} \sqrt{\frac{f_{yk}}{E} \frac{\eta \beta a}{\pi r}} \quad (\text{C5.3.48})$$

$$\eta = \frac{1}{\sqrt{\sigma_{culp}}} \quad (\text{C5.3.49})$$

$$r = \sqrt{\frac{I_T}{A_T}} \quad (\text{C5.3.50})$$

$$\beta = \begin{cases} \frac{1}{1.164C^{0.251}} & (0 < C \leq 0.54) \\ 1.0 & (0.54 < C) \end{cases} \quad (\text{C5.3.51})$$

$$e = \frac{h_r^2 t_r - b t^2 / n}{2A_T} \quad (\text{C5.3.52})$$

$$C = \left(\frac{a}{b} \right)^3 \frac{I_t}{I_T} \quad (\text{C5.3.53})$$

$$I_t = \frac{h_t^3 t_t}{3} \quad (\text{C5.3.54})$$

$$I_T = \frac{1}{3} \left(h_r^3 t_r - \frac{b t^3}{n} \right) - e^2 A_T \quad (\text{C5.3.55})$$

$$A_T = \frac{b t}{n} + h_r t_r \quad (\text{C5.3.56})$$

- where ,
- a : Span of stiffeners in the transverse direction
 - h_r : Height of stiffener in the longitudinal direction
 - t_r : Thickness of stiffener in the longitudinal direction
 - h_t : Height of stiffener in the transverse direction
 - t_t : Thickness of stiffener in the transverse direction
 - R_{cp} : Width-thickness ratio of compression plate enclosed by transverse and longitudinal stiffeners
 - E : Young's modulus of steel
 - f_{yk} : Characteristic value of material strength (standard value)
 - f_{yr} : Standard value of material strength (235 N/mm²)

- (6) The local buckling strength of a plate supported on all edges and subject to shear stress should be computed by:

$$\tau_{rd} = \begin{cases} \frac{f_{vyd}}{\gamma_b} & (R_r \leq 0.60) \\ \left(\frac{0.6}{R_r} \right)^{0.32} \frac{f_{vyd}}{\gamma_b} & (0.60 < R_r) \end{cases} \quad (\text{C5.3.57})$$

- where ,
- τ_{rd} : Design shear strength
 - f_{vyd} : Design material shear strength
 - R_r : Width-thickness ratio ,

$$R_r = \frac{1}{\pi} \sqrt{\frac{12(1-\nu^2)}{k_r}} \sqrt{\frac{f_{vyk}}{E}} \frac{b}{t}$$

- f_{vyk} : Characteristic value of material shear strength
 ν : Poisson's ratio
 E : Young's modulus of steel
 k_r : Buckling coefficient

$$k_r = \begin{cases} 5.34 + 4.0 \left(\frac{b}{a}\right)^2 & \left(1 < \frac{a}{b}\right) \\ 4.0 + 5.34 \left(\frac{b}{a}\right)^2 & \left(1 \geq \frac{a}{b}\right) \end{cases} \quad (\text{C5.3.58})$$

a : Distance between fixed edges of plate (in the longitudinal direction) (refer to Fig.C5.3.8)

b : Distance between fixed edges of plate (in the transverse direction) (refer to Fig.C5.3.8)

t : Plate thickness

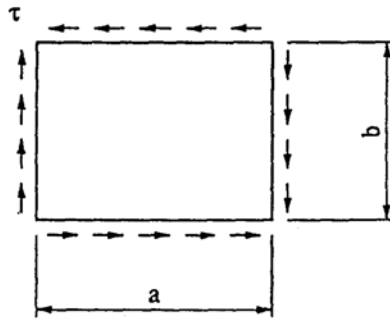

Fig.C5.3.8 Distance between fixed edges of plate

- (7) The local buckling strength of a plate support at both edges and subject to local loading should, in principle, be computed using Eq.(C5.3.59).

$$\sigma_{rd} = \begin{cases} \frac{f_{yd}}{\gamma_b} & (R \leq 0.70) \\ \left(\frac{0.7}{R}\right)^{0.80} \frac{f_{yd}}{\gamma_b} & (0.70 < R) \end{cases} \quad (\text{C5.3.59})$$

Where, σ_{rd} is the design local buckling strength, which must correspond to stress level σ_{p1} at a position on the upper edge of the panel in question. As shown in Fig.C5.3.9, when the distances from the edge of the panel in question to the upper and lower boundaries of the loading are taken as d_1 and d_2 , respectively, the relationship between σ_{p1} and the stress level σ_{p0} at the loading or local load P shall be obtained using the following equation:

$$\sigma_{p1} = \sigma_{p0} \left(1 - \frac{d_1}{d}\right) = \frac{P}{ct} \left(1 - \frac{d_1}{d}\right) \quad (\text{C5.3.60})$$

- where , f_{yd} : Design material strength
 R : Width-thickness ratio ,

$$R = 1.05 \sqrt{\frac{f_{yk}}{k_p E} \frac{b}{t}}$$

k_p : Local buckling coefficient given by Eq.(5.3.61)

$$\left. \begin{aligned} k_p &= \left[0.8 + 2.4 \left(\frac{b}{a} \right)^2 \right] \left(\frac{c}{a} + \frac{a}{c} \right) \eta_p \\ \eta_p &= \frac{\psi_p^2 + 3\psi_p + 1}{(1 + \psi_p)^3} \end{aligned} \right\} \quad (\text{C5.3.61})$$

E : Young's modulus of steel

f_{yk} : Characteristic value of material strength (standard value)

b : Distance between fixed edges of plate (in the longitudinal direction) given in Fig.C5.3.9

t : Plate thickness

c : Width of local loading on the upper edge of the panel shown in Fig.C5.3.9

a : Distance between fixed edges of plate (in the transverse direction) shown in Fig.C5.3.9.

When a exceeds a_{cr} calculated using Eq.(C5.3.62), a_{cr} should be used instead of a .

$$a_{cr} = \begin{cases} \frac{b^2}{10c} + b + c & (b \leq c) \\ 1.5b + 0.6c & (c < b) \end{cases} \quad (\text{C5.3.62})$$

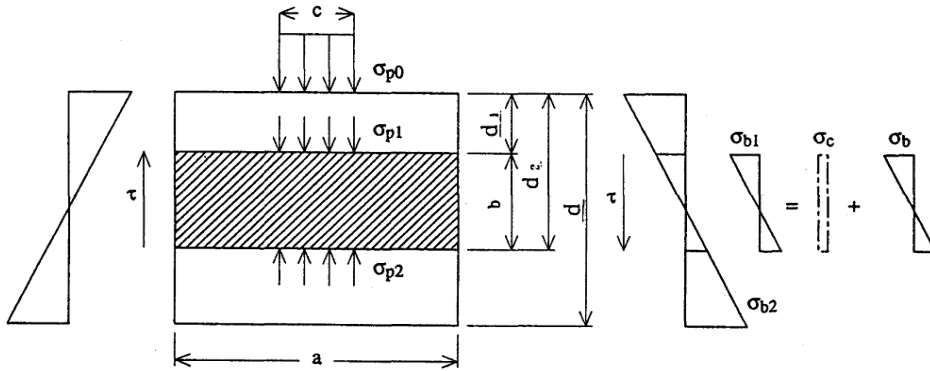

Fig.C5.3.9 Dimensions and stress levels of panel subject to local loading

ψ_p : Ratio of σ_{p2} to σ_{p1} computed by Eq.(C5.3.63)

$$\psi_p = \frac{\sigma_{p2}}{\sigma_{p1}} = \frac{d - d_2}{d - d_1} \quad (\text{C5.3.63})$$

The elastic buckling stress of a constant thickness rectangular plate subject to local loading (width c) on its upper edge and simply supported on all edges is given by Eq.(C5.3.64).

$$\sigma_{pcr} = k_p \frac{\pi^2 E}{12(1 - \nu^2)} \left(\frac{t}{b} \right)^2 \quad (\text{解 5.3.64})$$

Based on this stress, the slenderness ratio is defined as follows.

$$R = \sqrt{\frac{f_{yk}}{\sigma_{pcr}}} = \frac{b}{\pi t} \sqrt{\frac{12(1 - \nu^2)}{k_p}} \sqrt{\frac{f_{yk}}{E}}$$

The local buckling strength of a plate subject to local loading is determined by considering the reduction of the local buckling resistance due to residual stress and initial deformation with the buckling coefficient calculated by Eq.(C5.3.65). The resistance larger than elastic buckling stress

is adopted for relatively large R -value region since the post-buckling resistance can be expected. .

Design method of a plate subject to local loading against buckling can be found in some foreign design codes such as BS5400 [1982] and DASt.Ri012 [1978]. The calculation method of buckling coefficient is given in each code. In this specification, Eq.(C5.3.65), which is the approximation of the coefficient given by Moriwaki et al. [1983], is adopted as the formula to obtain buckling coefficient k_p .

$$k_p = \left[0.8 + 2.4 \left(\frac{b}{a} \right)^2 \right] \left(\frac{c}{a} + \frac{a}{c} \right) \quad (\text{解 } 5.3.65)$$

Where, $a = a_{cr}$ for $a > a_{cr}$, and

$$a_{cr} = \begin{cases} \frac{b^2}{10c} + b + c & (b \leq c) \\ 1.5b + 0.6c & (c < b) \end{cases}$$

In Eq.(C5.3.61), a correction factor $\eta_p \psi_p$ based on the reference [Takimoto, 1989] is introduced to take the influence of ψ_p .

It should be noted that the meaning of buckling coefficient for a plate subject to local loading may be different even if the same symbol (k) is used. The same type definition of the buckling coefficient as a plate in compression is adopted in this specification as shown in Eq.(C5.3.64).

Careful attention should be paid to the treatment of σ_p when the equation in this specification is applied. In-plane stress induced by local loading is complicated. Methods for strict treatment of this can be found in some references [Ito, 1984; JSCE, 1988; DASt.Ri012, 1978]. Since σ_{p1} and σ_{p2} are shown here as the expedient values to verify buckling resistance, it is not appropriate to use them for other resistance evaluation like fatigue.

5.4 Resistance of Steel Pipes

- (1) The tensile resistance and compressive resistance of steel pipes shall be determined according to the provisions in 5.3.1 and 5.3.2.
- (2) The bending resistance of steel pipes shall be determined on the basis of local buckling resistance against compressive stress in the axial direction, bending stress, or a combination of the two stresses.
- (3) The shear resistance of steel pipes shall be determined in consideration of factors such as boundary conditions, initial imperfections due to welding, including initial deformation and residual stress, and whether the pipe is stiffened with rings or diaphragms.

【 Commentary 】

- (1) The design bending resistance of a steel pipe is generally computed using Eq.(C5.4.1).

$$M_{bu} = M_n \frac{\sigma_{rd}}{f_{yd}} \quad (\text{C5.4.1})$$

where , $M_n = f_{yd} \times W$

W : Sectional modulus of the outer edge of the steel pipe

f_{yd} : Design material strength

σ_{rd} : Design compressive strength corresponding to local buckling of the steel pipe, obtained from Eq.(C5.4.4)

- (2) The design local buckling strength of a steel pipe under compression stress is generally computed

using Eq.(C5.4.2).

$$\sigma_{rd} = \begin{cases} \frac{f_{yd}}{\gamma_b} & (R_t \leq 0.119) \\ \left(0.723 + \frac{0.0330}{R_t}\right) \frac{f_{yd}}{\gamma_b} & (0.119 < R_t \leq 0.355) \end{cases} \quad (C5.4.2)$$

where , σ_{rd} : Design compressive strength corresponding to local buckling of the steel pipe

f_{yd} : Design material strength

R_t : Radius-thickness ratio ,

$$R_t = 1.65 \frac{f_{yk} r}{E t}$$

f_{yk} : Characteristic value of material strength (standard value)

E : Young's modulus of steel

t : Wall thickness of steel pipe

r : Radius of steel pipe (distance from center to outer edge)

- (3) The design local buckling strength of a steel pipe under bending stress is generally computed using Eq.(C5.4.3).

$$\sigma_{rd} = \begin{cases} 1.20 \frac{f_{yd}}{\gamma_b} & (R_t \leq 0.099) \\ \left(0.867 + \frac{0.0330}{R_t}\right) \frac{f_{yd}}{\gamma_b} & (0.099 < R_t \leq 0.279) \end{cases} \quad (C5.4.3)$$

Where , σ_{rd} : Design bending strength in compression of the steel pipe

$f_{yd}, f_{yk}, R_t, t, r$: as defined in (Eq.(C5.4.2)) .

- (4) The design local buckling strength of a steel pipe under both bending and compressive stresses is generally computed using Eq.(C5.4.4).

$$\sigma_{rd} = \begin{cases} f \frac{f_{yd}}{\gamma_b} & (R_t \leq 0.119) \\ \left(0.723f + \frac{0.0330}{R_t}\right) \frac{f_{yd}}{\gamma_b} & \left(\frac{0.119}{f} < R_t \leq \frac{0.355}{f}\right) \end{cases} \quad (C5.4.4)$$

where , σ_{rd} : Design compressive strength corresponding to local buckling of steel pipe

f : Coefficient depending on stress gradient $f = 1 + \frac{\phi}{10}$

ϕ : Stress gradient

$$\phi = \frac{\sigma_1 - \sigma_2}{\sigma_1} \quad (0 < \phi < 2)$$

σ_1 : Total stress level on the side of the steel pipe where compression occurs. The sign shall be taken as positive for compressive stress.

σ_2 : Total stress level on the side of the steel pipe where tension occurs. The sign shall be taken as positive for compressive stress.

$f_{yd}, f_{yk}, R_t, t, r$ is defined in (Eq.(C5.4.2))

- (5) The design shear strength of a steel pipe is generally computed using Eq.(C5.4.5) when it is strengthened with rings or diaphragms.

$$\tau_{rd} = \begin{cases} \frac{f_{vyd}}{\gamma_b} & (R_r \leq 0.638) \\ \frac{0.57 f_{vyd}}{R_r^{1.25}} \frac{1}{\gamma_b} & (0.638 < R_r \leq 1.50) \end{cases} \quad (C5.4.5)$$

where , τ_{rd} : Design shear strength of steel pipe

R_r : Radius-thickness ratio parameter,

$$R_r = 2.63 \left(\frac{f_{vyk}}{E} \right)^{0.8} \frac{r}{t}$$

E : Young's modulus of steel

t : Wall thickness of steel pipe

r : Radius of steel pipe (distance from center to outer edge)

f_{vyk} : Characteristic value of material shear strength

5.5 Resistance of Cables

The design resistance of cables shall be taken as the value calculated by equation (5.5.1).

$$N_{rd} = \frac{A_n f_d}{\gamma_b} \quad (5.5.1)$$

where, N_{rd} : design resistance of cables

f_d : design strength of the material

A_n : nominal cross sectional area of the cable

γ_b : structural member factor

【 Commentary 】

As a general rule, the wires in parallel wire strands must not have joints except when using the AS construction method.

In computing the strength of wire joints in the AS construction method, the partial factor of members at the joints can be made smaller value than that for the non-jointed portions according to a responsible engineering judgment based on a consideration of the efficiency of field joints. It must be verified through tests at the plant that the strength of joints exceeds that of non-jointed portions. As an example, in [HSBA, 1980], the allowable stress of wires making up a cable is reduced to 6200kgf/cm²(≐610N/mm²) from the standard value of 6400kgf/cm²(≐630N/mm²) at joints. The characteristic value of material strength for cable wires can be defined either as the ultimate strength of the wire or as 0.7% or 0.8% of total elongation strength. The latter is generally used.

For further reference, the results of investigations by the Honshu-Shikoku Bridge Authority [HSBA, 2003] are presented here as a recent example. The investigation concluded that 0.8% of the actual measured value of total elongation resistance can be used as the standard wire strength for design when wires with the same specification and manufactured by the same method as those used for Akashi Kaikyo Bridge are employed in future projects. These suspension bridge cables were manufactured using very special techniques and the standard of quality control was particularly high. The total elongation for defining resistance was revised from 0.7% to 0.8% when the 180kgf/mm²(≐1760N/mm²) wire developed for the Akashi Kaikyo Bridge replaced the 160kgf/mm²(≐1570N/mm²) wire used for the Seto-Ohashi and other bridges constructed earlier by the HSBA (corresponding to the design code mentioned above, [HSBA, 1980]). The resistance of the wires for the Akashi Kaikyo Bridge is defined as a minimum of 140kgf/mm²(≐1370N/mm²) in the specification, but actually measured values for 3,016 specimens were very stable, with an average value of 152.5kgf/mm²(≐1495N/mm²) and a standard deviation of 1.66kgf/mm²(≐16.3N/mm²). A value of 150kgf/mm²(≐1470N/mm²) was adopted as the standard value for design by rounding down this average value.

References in Chapter 5

- Bleich, F.(1952) : Buckling Strength of Metal Structure, McGRAW-HILL.
- DAST-Richtlinie 012(1978) : Deutscher Ausschuss für Stahlbau .
- Study Group of Structures in Tokai(1980) : Evaluation of Strength of Steel Structural Members and Its Application to a Reliability Design, Bridge and Foundation Engineering, Vol.14, No.11.
- Honshu-Shikoku Bridge Authority(1980) : Design Specifications for Superstructure.
- BS5400(1982) : British Standards Institution; Part 3 .
- Moriwaki, R., Takimoto, T. and Mimura, Y.(1983) : Ultimate Strength of Girders under Patch Loading, Proceedings of JSCE, No.339.
- Ito, K.(1984) : An Example of Stability Verification of Plate Girder Web under Vertical Patch Loading according to .
- Japan Society of Civil Engineers(1988) : Collaborate Research Report on Strength and Design of Thin-walled Structures, Kansai Branch.
- Takimoto, T.(1989) : Buckling Strength of Girder Webs under Patch Loading, R&D Kobe Steel Engineering Reports, Vol.39.
- Japan Society of Civil Engineers (1994) : Ultimate Strength and Design of Steel Structure, Steel Structure Series 6 .
- Japan Society of Civil Engineers (1997a) : Design Code for Steel Structures, PART A; Structures in General.
- Japan Society of Civil Engineers (1997b) : Design Code for Steel Structures, PART B; Composite Structures.
- ISO(1997) : ISO10721 Steel Structures, Part 1 : Material and Design .
- AASHTO(1998) : LRFD Bridge Design Specifications, SI Unit Second Edition .
- Japan Road Association (2002) : Specifications for Highway Bridges and Commentary .
- Honshu-Shikoku Bridge Authority(2003) : Committee Report on Safety Factor of Cables for Strait Crossing Road.
- Japan Society of Civil Engineers(2005) : Buckling Design Guidelines, Ver.2 [2005 Version].
- CEN(2003) : Eurocode 3 Design of Steel Structures, Part 2: Steel Bridges -, prEN 1993-2 .

Chapter 6 Demand for Safety and Verification

6.1 General

- (1) Safety shall be verified in consideration of all actions that might arise during the erection period and the design working life.
- (2) Structural safety and public safety shall be the performance items verified to meet the safety requirement.
- (3) An appropriate limit state shall be established for each performance item and safety shall be verified against the limit states of all performance items.

【Commentary】

In the specifications, two performance requirements are prescribed for safety: structural safety and public safety. The former deals with the safety of the structure itself as judged, for example, by its load-carrying capacity, while the latter relates to ensuring the safety of any members of the public present in the neighborhood of the structure. Depending on the circumstances of the structure's location, public safety may not be a factor. In this chapter, therefore, the specific verification procedures only for structural safety are provided. It should also be noted that the safety of structural members and structural elements is dealt in this chapter, while the safety of connections is left for Chapter 11 "Joints." The performance requirements given in this chapter are the basic ones for composite structures and their verification, but the computation of load-carrying capacities in some situations are different in the case of composite structures and they have some unique structural components, such as shear connectors. Their safety is therefore discussed separately in Chapter 15 "Design of Composite Girders" for the benefit of readers.

Structural safety is usually verified by ensuring that the loading capacity of the structure exceeds demand. As actions such as loads increase, deformation and induced stress increase and the structure may change state from elastic behavior to elasto-plastic behavior, and/or from stable behavior to unstable behavior. This will eventually lead to structural failure. To be specific, in the course of this failure process, structural performance needs to be verified from various viewpoints associated with elastic response, plastic response, buckling, stability as a rigid-body, stability of the whole structure, displacement/deformation, and so forth.

6.2 Performance Requirement for Safety

6.2.1 Structural Safety

Steel and composite structures shall satisfy the requirements for load-carrying and displacement/deformation capacity and also shall be stable under the actions given in Chapter 2.

【Commentary】

Structural safety concerns two aspects of structural performance: load-carrying capacity and stability. The phenomena associated with load-carrying capacity include member fracture, local buckling of a plate, buckling of a member, and buckling of the whole structure. The load-carrying capacity of the structure is influenced by material strength (tensile strength, compressive strength, shear strength,

etc.), buckling strength, deformation capacity, fabrication and erection imperfections, and so on. The major causes of loss of stability are sudden loss of stiffness due to buckling and the collapse, sliding, or uplift of the whole structure and/or part of the structure.

As actions such as loads increase, deformation and induced stress increase. As a result, a structure that is in an elastic state may become elasto-plastic, and/or a stable structure may become unstable. Eventually, failure will take place. Even if part of a structure reaches a state of failure, the failure of the whole structure has to be prevented under the actions specified in Chapter 2. To that end, it is desirable to verify this performance requirement by direct simulation. However, at the current stage of development, such a simulation is not practical for day-to-day design. Therefore, the basic approach in this code is to verify that members and connections possess sufficient load-carrying capacity. It should be noted that design for seismic loads of level 2 is exceptional; the capacity of the whole structure is to be verified even in the current design practice. This class of design is dealt with in the Seismic Volume of the standards specifications.

The limit states that control structural performance with respect to load-carrying capacity, displacement/deformation, and stability can be set at various points during the course of progressive failure for a member or for the whole structure, depending on the objective, the importance, the restorability requirements of the structure, and so on. The importance of the structure is determined from its expected working life, the function of its members, and the effect that collapse would have. The load-carrying capacity, displacement/deformation capacity, and stability need to be determined by considering these aspects appropriately.

In practice, the actions to which a structure is subjected, the method of structural analysis, the partial factors, and so on can vary depending how the strength limit states are set. In past design codes for steel and composites structures, the elastic limit was assumed to be the load-carrying capacity that can generally be relied on for structural safety, regardless as to whether the code is based on allowable stress design or limit state design. However, if the cross section of a member is compact, the state where the whole cross section becomes plastic may be taken as the load-carrying capacity of the member.

6.2.2 Public Safety

The public shall be protected from any possible hazard that a steel or composite structure might pose throughout its service life.

【 Commentary 】

If a structure sheds cover concrete or high-tensile bolts (due to delayed failure), injury may occur to the public and damage any property below. Public safety is the performance that is required to prevent such incidents.

No specific verification methods are given here, but depending on the surroundings of the structure, design engineers are required to institute performance requirements and to carefully select materials and the implementation of preventive measures.

6.3 Verification of Structural Safety

6.3.1 Verification of load-carrying capacity

The verification of load-carrying capacity shall entail ensuring that the design action effect is smaller than the design member capacity.

【 Commentary 】

Although performance-based design does not impose any restrictions on the choice of approach to the verification of structural safety, the reliability-based design method is becoming the global standard. Nevertheless, sufficient probabilistic data are not always available, so quite often the probability of failure cannot be evaluated directly. Therefore, this code employs the partial-factor method as the basic verification approach. Details of the partial-factor method are given in Chapter 1 "General" of the General Provisions Volume.

6.3.1.1 Verification of load-carrying capacity of members in framed structure

The load-carrying capacity of a structural member in a framed structure shall be verified for all applicable cases among the following:

- (1) axial force
- (2) bending moment
- (3) combined axial force and bending moment
- (4) shear force or a combination of shear force and torsional moment
- (5) combined axial force, bending moment, and shear force
- (6) biaxial stress in the above five cases when significant

【 Commentary 】

For each verification item of structural safety, the verification equations in the Design Code for Steel Structures [JSCE, 1997] are presented here as an example of a possible verification approach in the form of the partial factor method.

(1) Verification of axial force capacity

The safety performance of a member subjected to axial force can be verified using the following equation:

$$\gamma_i \frac{N_{sd}}{N_{rd}} \leq 1.0 \quad (\text{C6.3.1})$$

where , γ_i : structure factor
 N_{sd} : design axial force
 N_{rd} : design axial force resistance

Using this verification equation, the demand, the resistance (limit value), and the partial factor in this code are explained.

The structure under loading by the product of the characteristic design load and the load factor is analyzed by the relevant method. The axial force thus obtained is then multiplied by the structural analysis factor. This final axial force result is the demand, N_{sd} , in Eq.(C6.3.1). The design axial force resistance, N_{rd} , is the lower bound of the capacity evaluated by considering the scatter in material properties, size, and shape as well as the effects of the fabrication process and possible local buckling by way of partial factors. More details of this process are available in Chapter 5. Performance is verified if the resistance (limit value) is found to be greater than the demand; here the structure factor that represents the importance of the structure needs to be taken into account.

(2) Verification of bending moment capacity

The safety performance of a member subjected to bending moment can be verified using the following equation:

$$\gamma_i \frac{M_{sd}}{M_{rd}} \leq 1.0 \quad (\text{C6.3.2})$$

where , γ_i : structure factor
 M_{sd} : design bending moment
 M_{rd} : design bending moment capacity based on the classification of cross sections in 5.3.3.1 (Table C5.3.3.)

In the allowable stress design method widely-used at present, the bending moment capacity of a member is given by one of the following limit states being reached: yielding at the edge of a cross section, global lateral-torsional buckling, or local buckling. However, in view of performance-based design, it would be more desirable if the bending moment capacity beyond the local buckling of a thin-walled member or up to the plastic moment of a thick-walled member could be taken into account in design. To that end, the interaction of plastic deformation, local buckling, and global lateral-torsional buckling needs be evaluated properly and the classification of the cross sections based on the plastic limit width-thickness ratio and the elastic limit width-thickness ratio would then be required. For the verification of a composite girder, it is necessary to evaluate the design bending-moment effect and the design bending moment capacity by taking the composite action into consideration, the details of which are given in Chapter 15. It should be noted that the verification equation is commonly expressed in the following form, in which the components in two directions (y-direction, z-direction) are summed:

$$c \left(\gamma_i \frac{M_{sdy}}{M_{r dy}} \right)^a + d \left(\gamma_i \frac{M_{sdz}}{M_{r dz}} \right)^b \leq 1.0 \quad (\text{C6.3.3})$$

where , a, b, c, d : the constants, the values of which depend on the classification of the cross section, the shape of the cross section, and so on.

< Example of Verification of Capacity under Bending Moment (Design Code for Steel Structures Part A (JSCE 1997)) >

Slender Section, Non-compact Section, Compact Section

a) Verification of cross-section capacity

$$\gamma_i \left(\frac{M_{sdy}}{M_{r dy}} + \frac{M_{sdz}}{M_{r dz}} \right) \leq 1.0 \quad (\text{C6.3.4})$$

b) Verification of member capacity

$$\gamma_i \left(\frac{M_{sdy}}{M_{r dy}} + \frac{M_{sdz}}{M_{br dz}} \right) \leq 1.0 \quad (\text{C6.3.5})$$

Compact section

Box-, I-, and H-shaped cross sections:

a) Verification of cross-section capacity

Box-shaped, π -applied and circular cross sections:

$$\frac{3}{4} \left(\gamma_i \frac{M_{sdy}}{M_{r dy}} \right)^2 + \gamma_i \frac{M_{sdz}}{M_{r dz}} \leq 1.0 \quad \text{for } \frac{M_{sdy}}{M_{r dy}} \leq \frac{M_{sdz}}{M_{r dz}} \quad (\text{C6.3.6})$$

$$\gamma_i \frac{M_{sdy}}{M_{r dy}} + \frac{3}{4} \left(\gamma_i \frac{M_{sdz}}{M_{r dz}} \right)^2 \leq 1.0 \quad \text{for } \frac{M_{sdy}}{M_{r dy}} > \frac{M_{sdz}}{M_{r dz}} \quad (\text{C6.3.7})$$

I- and H-shaped cross sections:

$$\gamma_i \frac{M_{sdy}}{M_{r dy}} + \left(\gamma_i \frac{M_{sdz}}{M_{r dz}} \right)^2 \leq 1.0 \quad (\text{C6.3.8})$$

b) Verification of member capacity

$$\gamma_i^\alpha \left\{ \left(\frac{M_{sdy}}{M_{r dy}} \right)^\alpha + \left(\frac{M_{sdz}}{M_{br dz}} \right)^\alpha \right\} \leq 1.0 \quad (\text{C6.3.9})$$

- where ,
- $\alpha = 1.4$ for box-shaped cross sections
 - $\alpha = 1.0$ for I- and H-shaped cross sections with $B/D < 0.3$
 - $\alpha = 0.4 + B/D \geq 1.0$ with B/D
 - B : flange width
 - D : height of the cross section
 - M_{sdy}, M_{sdz} : design bending moments about the weak and strong axes acting in the cross section to be verified, respectively. When the bending moments vary linearly along the member, M_{sdy}, M_{sdz} in Eq.(C6.3.7) may be replaced by the equivalent bending moments M_{eqy}, M_{eqz} , respectively.
 - M_{eqy}, M_{eqz} : equivalent bending moments about the weak and strong axes, respectively, given by the following formula:

$$M_{eq} = 0.6M_1 + 0.4M_2 \geq 0.4M_1$$
 where M_1, M_2 are the bending moments at the ends of the member, and $M_1 > M_2$ where the bending moment is positive when stress in the flange under consideration is compressive.
 - M_{rdy}, M_{rdz} : design bending-moment capacities about the weak and strong axes, respectively, of the cross section to be verified, which are evaluated by referring to the classification of cross sections in section 5.3.3.1. Using the base bending-moment capacities M_{ny}, M_{nz} given in section 5.3.3.2, they can be expressed as follows:

$$M_{rdy} = M_{ny}/\gamma_b, \quad M_{rdz} = M_{nz}/\gamma_b$$
 For a cross section that cannot attain the plastic moment M_p , the verification must be ensured for both tension and compression sides with M_{trdy}, M_{crdy} and M_{trdz}, M_{crdz}
 - M_{brdz} : design bending moment of the member for the verification, which includes the influence of lateral-torsional buckling about the weak axis. The capacity is given by Eq.(C5.3.2) in section 5.3.3.2, for example.

Explanation of the verification example

In principle, Eqs.(C6.3.4) and (C6.3.5) are used in this verification example. Eq.(C6.3.4) is the verification equation for the ultimate bending moment of each cross section in which local buckling effect is taken into account, and Eq.(C6.3.5) is the verification equation for lateral-torsional buckling capacity, which includes the effect of interaction with local buckling. In a beam with a compact section (that is, with a width-thickness ratio of the constituent plates so small that the plastic moment can be reached under bi-axial moments), a capacity greater than that evaluated by the simple addition of Eqs.(C6.3.4) and (C6.3.5) can be expected. Therefore, for rational design, the application of the nonlinear interaction strength Eqs.(C6.3.6) to (C6.3.9) is approved in this code.

(3) Verification of capacity under combined axial force and bending moment

The safety performance of a member subjected to both axial force and bending moment can be verified using the following equation:

$$\gamma_i \left(\frac{N_{sd}}{N_{rd}} + \frac{M_{sdy}}{M_{rdy}} + \frac{M_{sdz}}{M_{rdz}} \right) \leq 1.0 \quad (\text{C6.3.10})$$

- where ,
- N_{sd}, M_{sdy}, M_{sdz} : design axial force and design bending moments
 - N_{rd}, M_{rdy}, M_{rdz} : design axial force capacity and design bending-moment capacities referring to the classification of cross sections (Table C5.3.3) in section 5.3.3.1

< **Example of Verification of Capacity under Combined Axial Force and Bending Moment (Design Code for Steel Structures Part A (JSCE 1997))** >

Slender Section, Non-compact Section, Compact Section

1) Tensile axial force

The safety performance of a member subjected to both tensile axial force and bending moment can be verified using the following equation:

$$\gamma_i \left(\frac{N_{sd}}{N_{trd}} + \frac{M_{sdy}}{M_{trdy}} + \frac{M_{sdz}}{M_{trdz}} \right) \leq 1.0 \quad (C6.3.11)$$

$$\gamma_i \left(-\frac{N_{sd}}{N_{trd}} + \frac{M_{sdy}}{M_{crdy}} + \frac{M_{sdz}}{M_{crdz}} \right) \leq 1.0 \quad (C6.3.12)$$

$$\gamma_i \left(-\frac{N_{sd}}{N_{trd}} + \frac{M_{sdy}}{M_{crdy}} + \frac{M_{sdz}}{M_{brdz}} \right) \leq 1.0 \quad (C6.3.13)$$

2) Compressive axial force

The safety performance of a member subjected to both compressive axial force and bending moment can be verified using the following equation:

$$\gamma_i \left(\frac{N_{sd}}{N_{crd}} + \frac{M_{sdy}}{M_{crdy}} + \frac{M_{sdz}}{M_{crdz}} \right) \leq 1.0 \quad (C6.3.14)$$

$$\gamma_i \left(-\frac{N_{sd}}{N_{trd}} + \frac{M_{sdy}}{M_{trdy}} + \frac{M_{sdz}}{M_{trdz}} \right) \leq 1.0 \quad (C6.3.15)$$

$$\gamma_i \left\{ \frac{N_{sd}}{N_{crd}} + \frac{M_{sdy}}{M_{crdy}(1 - N_{sd}/N_{cry})} + \frac{M_{sdz}}{M_{brdz}(1 - N_{sd}/N_{crz})} \right\} \leq 1.0 \quad (C6.3.16)$$

Compact section

1) Tensile axial force

The capacity of a compact section subjected to both tensile axial force and bending moment can be verified using the following equation:

$$\gamma_i \left(-\frac{N_{sd}}{N_{trd}} + \frac{M_{sdy}}{M_{crdy}} + \frac{M_{sdz}}{M_{brdz}} \right) \leq 1.0 \quad (C6.3.17)$$

Further verification is required using the following verification equations for the respective cross-section types:

a) Cross-sectional capacity of box-shaped cross section or circular hollow cross section

$$\frac{3}{4} \left(\gamma_i \frac{M_{sdy}}{M_{npy}} \right)^2 + \gamma_i \frac{M_{sdz}}{M_{npz}} \leq 1.0 \quad \text{for } \frac{M_{sdy}}{M_{npy}} \leq \frac{M_{sdz}}{M_{npz}} \quad (C6.3.18)$$

$$\gamma_i \frac{M_{sdy}}{M_{npy}} + \frac{3}{4} \left(\gamma_i \frac{M_{sdz}}{M_{npz}} \right)^2 \leq 1.0 \quad \text{for } \frac{M_{sdy}}{M_{npy}} > \frac{M_{sdz}}{M_{npz}} \quad (C6.3.19)$$

where , $M_{npy} = C \left(1 - \frac{N_{sd}}{N_{trd}} \right) \frac{M_{py}}{\gamma_b} \leq \frac{M_{py}}{\gamma_b}$ $C = 1.18$ for a box-shaped cross section , $C = 1.25$
 $M_{npz} = C \left(1 - \frac{N_{sd}}{N_{trd}} \right) \frac{M_{pz}}{\gamma_b} \leq \frac{M_{pz}}{\gamma_b}$
for a circular hollow cross section

b) Cross-sectional capacity of I- or H-shaped cross sections

$$\gamma_i \frac{M_{sdy}}{M_{npy}} + \left(\gamma_i \frac{M_{sdz}}{M_{npz}} \right)^2 \leq 1.0 \quad (C6.3.20)$$

$$\text{where , } \quad M_{npy} = 1.19 \left\{ 1 - \left(\frac{N_{sd}}{N_{trd}} \right)^2 \right\} \frac{M_{py}}{\gamma_b} \leq \frac{M_{py}}{\gamma_b}$$

$$M_{npz} = 1.18 \left(1 - \frac{N_{sd}}{N_{trd}} \right) \frac{M_{pz}}{\gamma_b} \leq \frac{M_{pz}}{\gamma_b}$$

2) Compressive axial force

The capacity of a compact section subjected to both compressive axial force and bending moment can be verified using the following equations.

a) Box-shaped and circular hollow cross sections

The capacity of a cross section can be verified using the following equations:

$$\frac{3}{4} \left(\gamma_i \frac{M_{sdy}}{M_{npy}} \right)^2 + \gamma_i \frac{M_{sdz}}{M_{npz}} \leq 1.0 \quad \text{for } \frac{M_{sdy}}{M_{npy}} \leq \frac{M_{sdz}}{M_{npz}} \quad (\text{C6.3.21})$$

$$\gamma_i \frac{M_{sdy}}{M_{npy}} + \frac{3}{4} \left(\gamma_i \frac{M_{sdz}}{M_{npz}} \right)^2 \leq 1.0 \quad \text{for } \frac{M_{sdy}}{M_{npy}} > \frac{M_{sdz}}{M_{npz}} \quad (\text{C6.3.22})$$

$$\text{with , } \quad M_{npy} = C \left(1 - \frac{N_{sd}}{N_{trd}} \right) \frac{M_{py}}{\gamma_b} \leq \frac{M_{py}}{\gamma_b} \quad C = 1.18 \text{ for a box-shaped cross section and } C = 1.25$$

$$M_{npz} = C \left(1 - \frac{N_{sd}}{N_{trd}} \right) \frac{M_{pz}}{\gamma_b} \leq \frac{M_{pz}}{\gamma_b}$$

for a circular hollow cross section.

The capacity of a member can be verified using the following equation:

$$\left(\gamma_i \frac{M_{sdy}}{M_{nuy}} \right)^\alpha + \left(\gamma_i \frac{M_{sdz}}{M_{nuz}} \right)^\beta \leq 1.0 \quad (\text{C6.3.23})$$

$$\text{where , } \quad M_{nuy} = \left(1 - \frac{N_{sd}}{N_{crd}} \right) \left(1 - \frac{N_{sd}}{N_{cry}} \right) \frac{M_{py}}{\gamma_b}$$

$$M_{nuz} = \left(1 - \frac{N_{sd}}{N_{crd}} \right) \left(1 - \frac{N_{sd}}{N_{crz}} \right) \frac{M_{buz}}{\gamma_b}$$

$$\alpha = 1.3 + \frac{N_{sd}}{N_{crdl}} \frac{1000}{(\ell/r_y)^2} \geq 1.4$$

$$\beta = 1.3 + \frac{N_{sd}}{N_{crdl}} \frac{1000}{(\ell/r_z)^2} \geq 1.4$$

b) I- and H-shaped cross sections

The capacity of a cross section can be verified using the following equation:

$$\gamma_i \frac{M_{sdy}}{M_{npy}} + \left(\gamma_i \frac{M_{sdz}}{M_{npz}} \right)^2 \leq 1.0 \quad (\text{C6.3.24})$$

$$\text{where , } \quad M_{npy} = 1.19 \left\{ 1 - \left(\frac{N_{sd}}{N_{crdl}} \right)^2 \right\} \frac{M_{py}}{\gamma_b} \leq \frac{M_{py}}{\gamma_b}$$

$$M_{npz} = 1.18 \left(1 - \frac{N_{sd}}{N_{crdl}} \right) \frac{M_{pz}}{\gamma_b} \leq \frac{M_{pz}}{\gamma_b}$$

The capacity of a member can be verified using the following equation:

$$\gamma_i^\alpha \left\{ \left(\frac{M_{sdy}}{M_{nr dy}} \right)^\alpha + \left(\frac{M_{sdz}}{M_{nr dz}} \right)^\alpha \right\} \leq 1.0 \quad (\text{C6.3.25})$$

$$\alpha = 1.0 \quad (B/D < 0.3)$$

$$\alpha = 0.4 + \frac{N_{sd}}{N_{crdl}} + \frac{B}{D} \geq 1.0 \quad (B/D \geq 0.3)$$

$$M_{nr dy} = \left(1 - \frac{N_{sd}}{N_{crd}}\right) \left(1 - \frac{N_{sd}}{N_{cry}}\right) \frac{M_{py}}{\gamma_b}$$

$$M_{nr dz} = \left(1 - \frac{N_{sd}}{N_{crd}}\right) \left(1 - \frac{N_{sd}}{N_{crz}}\right) \frac{M_{br dz}}{\gamma_b}$$

where ,

B : flange width

D : height of the cross section

f_{yd} : design material strength

ℓ : effective buckling length of a member. The standard values are given in Table C5.3.1, but they have to be adjusted when the constraints are insufficient.

A_g : gross area of the cross section to be verified

r_y, r_z : radii-of-gyration of the gross area about the weak and strong axes, respectively

Z_y, Z_z : plastic section modulus of the gross area about the weak and strong axes, respectively

N_{sd} : absolute value of design axial force (N) .

M_{sdy}, M_{sdz} : design bending moments about the weak and strong axes acting in the cross section to be verified, respectively. However, when the moments vary linearly, M_{dy}, M_{dz} may be replaced by the equivalent bending moments, M_{eqy}, M_{eqz} , respectively.

M_{eqy}, M_{eqz} : equivalent bending moments about the weak and strong axes, respectively, given by the following formula:

$$M_{eq} = 0.6M_1 + 0.4M_2 \geq 0.4M_1$$

where , M_1, M_2 are the bending moments at the ends of the member, and $M_1 > M_2$ where the bending moment is positive when stress in the flange under consideration is compressive.

$M_{br dz}$: design bending moment capacity of a beam member to be verified, which takes into account the lateral-torsional buckling about the weak axis. For example, it can be evaluated using Eq.(C5.3.2) in section 5.3.3.2.

$M_{cr dy}, M_{cr dz}$: design bending-moment capacities about the weak and strong axes, respectively, of the cross section to be verified with the focus on the compressive side. These capacities are evaluated by referring to the classification of cross sections in section 5.3.3.1. Using the base bending-moment capacities of the cross section of a beam shown in section 5.3.3.2, M_{ny}, M_{nz} , those capacities can be expressed by the following equations:

$$M_{cr dy} = M_{ny}/\gamma_b, \quad M_{cr dz} = M_{nz}/\gamma_b$$

$M_{tr dy}, M_{tr dz}$: design bending-moment capacities about the weak and strong axes, respectively, of the cross section to be verified with the focus on the tensile side. These capacities are evaluated by referring to the classification of cross sections in section 5.3.3.1. Using the base bending-moment capacities of the cross section of a beam shown in section 5.3.3.2, M_{ny}, M_{nz} , those capacities can be expressed by the following equations:

$$M_{tr dy} = M_{ny}/\gamma_b, \quad M_{tr dz} = M_{nz}/\gamma_b$$

M_{py}, M_{pz} : plastic moments about the weak and strong axes of the cross section to be verified, respectively, given by the following equations:

$$M_{py} = f_{yd}Z_y, \quad M_{pz} = f_{yd}Z_z$$

N_{cry}, N_{crz} : Euler buckling loads about the weak and strong axes, respectively, given by the following equations with slenderness ratios $\bar{\lambda}$ in Eq.(C5.3.1):

$$N_{cry} = \frac{A_g f_{yd}}{\lambda_y^2}, \quad N_{crz} = \frac{A_g f_{yd}}{\lambda_z^2}$$

N_{crdl} : axial compressive resistance of the cross section that takes local buckling into account, which is given by the following equation:

$$N_{cul} = \frac{Q_c f_{yd} A_g}{\gamma_b}$$

N_{crd} : axial compressive force capacity of the member that takes local buckling into account, as given by Eq.(C5.3.1)

N_{trd} : axial tensile force capacity of the cross section given by the smaller of the values given by Eqs.(C5.3.1) and (C5.3.2)

Q_c : effective section modulus to include local-buckling effect, which is "the dimensionless strength of a short column undergoing local buckling" given by Eq.(C5.3.1)

Explanation of verification example

In Design Specifications for Highway Bridges, which is based on allowable stress design, the limit states due to yielding, the overall buckling of a member, and the local buckling of a cross section are assumed to be independent of each other even when the member is subjected to both axial force and bending moment. Verification equations that require only linear structural analysis have been constructed for each of those limit states, respectively. On the other hand, even for a member subjected to bending moment, the influence of local buckling is included by reducing the effective cross-sectional area in the above equations, while capacity can be expected to be greater than the initial yield point for a member with a compact section.

The above approach recognizes two cases of axial tension and axial compression, with verification equations established separately for the limit states associated with the two cases. For rational design, the nonlinear verification Eqs.(C6.3.18) to (C6.3.25) can be used for the verification of a member with a compact section.

(4) Verification of capacity under shear force or under combined shear force and torsional moment

1) The effective area of the cross section of a member subjected to shear force is the gross area of the web and is computed using the following equation:

$$\gamma_i \frac{V_{sd}}{V_{rd}} \leq 1.0 \quad (C6.3.26)$$

where , V_{sd} : design shear force
 V_{rd} : design shear resistance

2) The safety of a member subjected to combined shear force and torsional moment is verified using the following equation:

$$\gamma_i \left(\frac{V_{sd}}{V_{rd}} + \frac{T_{sd}}{T_{rd}} \right) \leq 1.0 \quad (C6.3.27)$$

where , V_{sd} : design shear force
 V_{rd} : design shear resistance
 T_{sd} : design torsional moment about the shear center
 T_{rd} : design torsional moment resistance about the shear center

The safety of a member such as a web against shear force in a plate girder or similar structure can be verified using approach 1) above based on the assumption that shear stress is constant over the

web. However, the safety verification of a flange requires the computation of shear stress by the shear flow theory, because shear stress varies along the center line of the plate.

Approach 2) above, which takes into account torsional moment as well as shear force, is used for cases such as curved members where the torsional effect cannot be ignored if loading is applied in the direction of the strong axis. In general, a box girder is designed with high torsional resistance when a significant torsional moment is expected.

< Example of Verification of Capacity under Combined Shear Force and Torsional Moment (Design Code for Steel Structures Part A (JSCE 1997)) >

Slender Section, Non-compact Section, Compact Section

1) By assuming that the gross area of the web is the effective area of the cross section when a member is subjected to shear force, the safety of the member against the shear force is verified using the following equation:

$$\gamma_i \frac{V_{sd}}{V_{rd}} \leq 1.0 \quad (\text{C6.3.28})$$

2) The safety of a member (box girder) against shear force and torsional moment is verified using the following equations:

$$\gamma_i \left(\frac{V_{sd}}{V_{rd}} + \frac{T_{sds}}{T_{srd}} + \frac{T_{sd\omega}}{T_{\omega rd}} \right) \leq 1.0 \quad (\text{C6.3.29})$$

$$\gamma_i \left(\frac{M_{sdz}}{M_{trdz}} + \frac{M_{sd\omega}}{M_{\omega rd}} \right) \leq 1.0 \quad (\text{C6.3.30})$$

$$\gamma_i \left(\frac{M_{sdz}}{M_{crdz}} + \frac{M_{sd\omega}}{M_{\omega rd}} \right) \leq 1.0 \quad (\text{C6.3.31})$$

Note that the St. Venant torsion, T_{sds} , and warping torsion, $T_{sd\omega}$, are negligible for $\kappa \leq 0.4$ and $\kappa > 10$, respectively, where torsional constant ratio κ is given by the following equation:

$$\kappa = \ell \sqrt{\frac{GK}{EI_{\omega\omega}}} \quad (\text{C6.3.32})$$

- where ,
- V_{sd} : design shear force
 - V_{rd} : design shear force resistance
 - T_{sds} : St. Venant torsion in the cross section
 - $T_{sd\omega}$: warping torsion in the cross section
 - M_{sdz} : bending moment in the cross section
 - $M_{sd\omega}$: bi-moment in the cross section
 - T_{srd} : design St. Venant torsion resistance of a cross section,

$$T_{srd} = \frac{\tau_{rd} K}{h}$$
 - K : torsional constant of a cross section
 - h : converted edge-distance for St. Venant torsion
 - $\tau_{rd} = \begin{cases} t & \text{(open cross-section)} \\ \frac{2A_c}{t \oint 1/t ds} & \text{(closed cross-section)} \end{cases}$
 - t : plate thickness
 - A_c : area enclosed by the centerline of plate thickness
 - s : coordinate along the centerline of plate thickness
 - $T_{\omega rd}$: design warping torsion resistance of a cross section

M_{trdz} : design bending moment resistance to verify the capacity on the tension side of the cross section given by

$$M_{trdz} = \frac{I_{zz} f_{yd}}{Z_t \gamma_b}$$

M_{crdz} : design bending moment resistance to verify the capacity on the compression side of the cross section given by

$$M_{crdz} = \frac{I_{zz} f_{yd}}{Z_c \gamma_b}$$

I_{zz} : moment of inertia about the strong axis of the cross section

Z_t, Z_c : distances from the origin of z -axis (neutral axis) to the edges on the compression and tension sides, respectively (mm)

$M_{\omega rd}$: design bi-moment resistance of the cross section given by

$$M_{\omega rd} = \frac{I_{\omega\omega} f_{yd}}{\omega_{max} \gamma_b}$$

$I_{\omega\omega}$: moment of inertia about the warping

ω_{max} : warping function

κ : torsional constant ratio

ℓ : span with respect to torsion

G : shear modulus

E : Young's modulus

Eq.(C6.3.28) is an approximate equation for verifying the safety of a member such as a plate girder or similar structural member subjected to shear force. By assuming the distribution of shear stress is constant over the web, as shown in Fig.C6.3.1, the effective area A_e of the cross section becomes equal to the area of the web. However, this kind of approximation cannot be made for a flange. Shear flow theory, in which shear stress varies along the centerline of plate thickness, must be employed and the shear stress thus computed needs to be used to verify the safety of the flange.

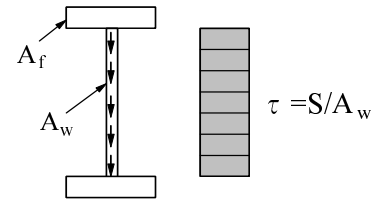

Fig.C6.3.1 Shear stress in web

Verification of structural safety against combined torsional moment and shear force needs to be carried out when the effect of torsion in a curved member becomes significant due to loading applied in the direction of the strong axis. In a plate girder or similar thin-walled member, the torsional moment is the sum of St. Venant torsion and warping torsion. The St. Venant torsion causes only shear stress in the cross section while the warping torsion induces normal stress due to warping as well as shear stress in equilibrium with that normal stress. In Eq.(C6.3.29), T_{sds} is the St. Venant torsion and $T_{sd\omega}$ is the warping torsion associated with warping. In Eqs.(C6.3.30) and (C6.3.31), M_{sdz} is the bending moment about the strong axis and $M_{sd\omega}$ is the bi-moment. In a thin-walled member subjected to torsional moment, both St. Venant torsion and warping torsion act. However, in general St. Venant torsion is dominant in a closed cross section such as a box girder, while warping torsion is greater in an open cross section such as an I-, π -, or U-shaped section. Since the contributions of the St. Venant torsion and the warping torsion can be estimated from the torsional constant ratio κ computed by Eq.(C6.3.32), it is stated that in Eq.(C6.3.29) only the warping torsion $T_{sd\omega}$ needs to be considered in the case of $\kappa < 0.4$ and that only the St. Venant torsion T_{sds} is important in the case of $\kappa > 10$. For $0.4 < \kappa < 10$, bending-torsional theory in which the effects of both the St. Venant torsion T_{sds} and the warping torsion $T_{sd\omega}$ are taken into account must be employed to verify safety. In general, a member under significant torsion is designed to have a box section which possesses large torsional

moment resistance.

(5) Verification of capacity under combined axial force, bending moment and shear force

The safety performance of a member subjected to combined axial force, bending moment, and shear force should be verified using the following equation:

$$\gamma_i^2 \left\{ \left(\frac{N_{sd}}{N_{rd}} + \frac{M_{sd}}{M_{rd1}} \right)^2 + \left(\frac{V_{sd}}{V_{rd}} \right)^2 \right\} / 1.21 \leq 1.0 \quad (\text{C6.3.33})$$

where , N_{sd}, M_{sd}, V_{sd} : axial force, design bending moment, and design shear force
 N_{rd}, M_{rd}, V_{rd} : design axial force resistance, design bending moment resistance,
and design shear force resistance

This verification equation deals with the situation where both normal and shear stresses act by utilizing the shear energy hypothesis. This hypothesis is good only for the elastic state, so no classification of cross sections is needed. For the verification of capacity against such a resultant, experience shows that the resistance in terms of stress can be increased by 10% in general, leading to the appearance of the figure 1.21 (the square of 1.1) in the denominator on the left hand side.

Note that when torsional moment is considered in addition to bending moment and shear force, the effect of the torsional moment has to be included in all terms associated with the bending moment and the shear force.

< **Example of Verification of Capacity under Resultant Stress (Design Code for Steel Structures Part A (JSCE 1997))** >

In a situation where both axial and shear stresses are significant, the resultant stress should be verified. Two such cases are illustrated here.

1) The safety performance of a member against combined axial force, bending moment, and shear force should be verified using the following equations

$$\gamma_i^2 \left\{ \left(\frac{N_{sd}}{N_{rd}} + \frac{M_{sdy}}{M_{rdy}} + \frac{M_{sdz}}{M_{rdz}} \right)^2 + \left(\frac{V_{sdy}}{V_{rdy}} + \frac{V_{sdz}}{V_{rdz}} \right)^2 \right\} / 1.21 \leq 1.0 \quad (\text{C6.3.34})$$

2) When the effect of torsional moment needs to be considered additionally, the following equation must be used:

$$\gamma_i^2 \left\{ \left(\frac{N_{sd}}{N_{rd}} + \frac{M_{sdy}}{M_{rdy}} + \frac{M_{sdz}}{M_{rdz}} + \frac{M_{sd\omega}}{M_{\omega rd}} \right)^2 + \left(\frac{V_{sdy}}{V_{rdy}} + \frac{V_{sdz}}{V_{rdz}} + \frac{T_{sds}}{T_{srd}} + \frac{T_{sd\omega}}{T_{\omega rd}} \right)^2 \right\} / 1.21 \leq 1.0 \quad (\text{C6.3.35})$$

where , N_{sd} : absolute value of design axial force
 M_{sdy}, M_{sdz} : design bending moments about the weak and strong axes in the cross section, respectively
 V_{sdy}, V_{sdz} : design shear forces in the y- and z-axes in the cross section, respectively
 T_{sds} : St. Venant torsion in the cross section
 $T_{sd\omega}$: warping torsion in the cross section
 $M_{sd\omega}$: bi-moment in the cross section
 N_{rd} : axial force resistance of the cross section given by

$$N_{rd} = \frac{A_n f_{yd}}{\gamma_b}$$
 f_{yd} : design material strength
 A_n : net area of the cross section to be verified

- M_{rdy}, M_{rdz} : design bending moment resistances about the weak and strong axes of the cross section to be verified, respectively
 $M_{rdy} = \frac{I_{yy}}{y} f_{yd}, M_{rdz} = \frac{I_{zz}}{z} f_{yd}$
- y, z : distances from the neutral axes of y - and z -axes to the respective edges of the cross section
- I_{yy}, I_{zz} : moments of inertias about the weak and strong axes of the cross section to be verified, respectively
- V_{rdy}, V_{rdz} : design shear force resistances in the direction of the weak and strong axes of the cross section to be verified, respectively
 $V_{rdy} = \frac{A_{ey} \tau_{rd}}{\gamma_b}, V_{rdz} = \frac{A_{ez} \tau_{rd}}{\gamma_b}$
- τ_{rd} : shear strength given by
 $\tau_{rd} = \frac{f_{yd}}{\sqrt{3}}$
- A_{ey}, A_{ez} : effective areas associated with the shear forces in the y - and z -axes, respectively
- T_{srd} : design St. Venant torsion resistance,
 $T_{srd} = \frac{\tau_{rd} K}{h}$
- K : design torsional constant of the cross section
- h : equivalent edge-distance for St. Venant torsion
 $= \begin{cases} t & \text{(open cross section)} \\ \frac{2A_c}{t \oint 1/t ds} & \text{(closed cross section)} \end{cases}$
- t : plate thickness
- A_c : area enclosed by the centerline of plate thickness
- s : coordinate along the centerline of plate thickness
- $T_{\omega rd}$: design warping torsion resistance of the cross section
 $T_{\omega rd} = \frac{I_{\omega\omega}}{(Q/t)_{max}} \tau_{rd}$
- $M_{\omega rd}$: design bi-moment resistance of the cross section
 $M_{\omega rd} = \frac{I_{\omega\omega}}{\omega_{max}} \frac{f_{yd}}{\gamma_b}$
- ω : warping function
- Q : torsional function
- $I_{\omega\omega}$: warping constant

(6) Verification of capacity when a state of significant biaxial stress is induced in the previous five cases (1)~(5)

A state of significant biaxial stress can develop in the members of a moment frame, for example, when a continuous stringer and a cross girder share a flange. The capacity under such a biaxial stress state needs be verified according to section 6.3.1.2 in addition to the verification given in (1) to (5) in section 6.3.1.1.

6.3.1.2 Verification of load-carrying capacity of plate

- (1) The load-carrying capacity of a plate shall, in principle, be verified for normal stress and shear stress using the following equations. These stress components shall be obtained from forces and/or moments acting in the cross section.

$$\gamma_i \frac{\sigma}{\sigma_{rd}} \leq 1.0 \quad (6.3.1)$$

$$\gamma_i \frac{\tau}{\tau_{rd}} \leq 1.0 \quad (6.3.2)$$

where , γ_i : structural factor
 σ : maximum normal stress in the cross section
 σ_{rd} : design strength
 τ : maximum shear stress in the cross section
 τ_{rd} : design shear strength

(2) The load-carrying capacity of a plate shall be verified for all applicable cases among the following:

- 1) in-plane forces
- 2) out-of-plane forces
- 3) combined in-plane and out-of-plane forces
- 4) stiffened plate subjected to in-plane forces
- 5) a steel pipe subjected to a combination of forces in the transverse section

【Commentary】

For each verification item of plate load-carrying capacity, a verification equation using the partial-factor method is presented here based on the Design Code for Steel Structures Part A [Japan Society of Civil Engineers, 1998] and Ultimate Strength and Design of Steel Structures [Japan Society of Civil Engineers, 1994].

1) Verification of plates subject to in-plane forces

The verification of plates subject to in-plane forces is performed by calculating the normal stress and shear stress from the applied cross-sectional force using Eqs.(6.3.1) and (6.3.2). Furthermore, because these verification equations apply to the maximum normal stress and maximum shear stress in the cross-sectional plane of the plate, they are applicable to generic plates without variations in shape or thickness.

Verification of the biaxial stress state is performed using the effective stress σ_{eff} given by Eq.(C6.3.36) and using Eq.(C6.3.37) derived from shear strain energy theory.

$$\sigma_{eff} = \sqrt{\sigma_x^2 - \sigma_x \sigma_y + \sigma_y^2 + 3\tau^2} \quad (C6.3.36)$$

$$\gamma_i^2 \frac{\sigma_{eff}^2}{(\sigma_{rd})^2} \frac{1}{(1.1)^2} \leq 1.0 \quad (C6.3.37)$$

The following equation, obtained by letting $\tau_{rd} = \sigma_{rd}/\sqrt{3}$, can also be used in Eqs.(C6.3.36) and (C6.3.37).

$$\gamma_i^2 \left\{ \left(\frac{\sigma_x}{\sigma_{rd}} \right)^2 - \left(\frac{\sigma_x}{\sigma_{rd}} \right) \left(\frac{\sigma_y}{\sigma_{rd}} \right) + \left(\frac{\sigma_y}{\sigma_{rd}} \right)^2 + \left(\frac{\tau}{\tau_{rd}} \right)^2 \right\} / 1.21 \leq 1.0 \quad (C6.3.38)$$

where , σ_x, σ_y : normal stress
 σ_{rd} : design strength obtained from Eq.(C5.3.35) or Eq.(C5.3.38)
 τ : shear stress
 τ_{rd} : design shear strength obtain from Eq.(C5.3.57)

Where the values 1.1² and 1.21 represent an adjustment factor relating to the accuracy of the equations; these values were set because research results relating to ultimate strength in the biaxial stress state

were smaller than research results relating to the ultimate strength in the uniaxial stress state. However, this value could also be set to 1.0 if the design engineer judges that sufficient accuracy is guaranteed.

Verification of buckling is performed using the following equation with the stress component calculated from the cross-sectional force.

$$\gamma_i^2 \left\{ \left(\frac{\sigma_x}{\sigma_{crdx}} \right) + \left(\frac{\sigma_x}{\sigma_{brdx}} \right)^2 + \left(\frac{\sigma_y}{\sigma_{crdy}} \right) + \left(\frac{\sigma_y}{\sigma_{brdy}} \right)^2 + \left(\frac{\tau}{\tau_{rd}} \right)^2 \right\} \leq 1.0 \quad (C6.3.39)$$

where , σ_x, σ_y : normal stresses acting in mutually perpendicular directions. These stresses should be taken as zero in the case of uniform tensile stress.

$\sigma_{crdx}, \sigma_{crdy}$: design strength obtained using Eq.(C5.3.35) and Eq.(C5.3.38)

$\sigma_{brdx}, \sigma_{brdy}$: design strength obtained using Eq.(C5.3.36)

τ : shear stress

τ_{rd} : design shear strength obtained using Eq.(C5.3.37)

This buckling verification applies only to flat rectangular plate elements of uniform thickness that are simply supported at the perimeter. If the plate element cannot be treated as flat and rectangular, or if the boundary conditions are different or the plate thickness is not uniform throughout the flat element, a verification of the limit state needs to be performed using an appropriate structural analysis method.

2) Verification of plates subject to out-of-plane forces

The verification of plates subject to out-of-plane forces consists of verification of stress and verification of the biaxial stress state. As a general rule, the maximum value in the cross-sectional plane is used for each stress component. In other words, verification of stress means verification at the outer edge of the plate and this can be performed by using the edge stress from the cross-sectional force and the maximum shear stress as calculated using Mohr's circle.. Even in the biaxial stress state, verification can be performed using Eq.(C6.3.37) by using the maximum value of each stress component in the same way.

Although verification of the shear stress distribution in the plate thickness direction is not required here because it applies to thin plates, the distribution of shear stress over the plate thickness is additionally required if the plate is treated as a thick plate. Verification of the biaxial stress state is performed using the effective stress. In plates that are subject to out-of-plane forces, because membrane effects can be anticipated in addition to plate characteristics as the out-of-plane deformation increases, strength may be higher in consideration of this point. However, this kind of strength increment is not considered because its applicability has not been appropriately identified in this code.

3) Verification of plates subject to in-plane and out-of-plane forces

For plates subject to in-plane and out-of-plane forces, it is assumed that verification of the combined stress and verification of the biaxial stress state are performed for the worst-case loading conditions with reference to items 1) and 2) in section 6.3.1.2 and, if necessary, buckling of the plate should be verified. Each stress is taken as a combined stress resulting from the stress due to in-plane forces and the stress due to out-of-plane forces as shown below.

$$\sigma_{rd} = \sigma_{rd,ip} + \sigma_{rd,op} \quad (C6.3.40)$$

$$\sigma_{xrd} = \sigma_{xrd,ip} + \sigma_{xrd,op} \quad (C6.3.41)$$

$$\sigma_{yrd} = \sigma_{yrd,ip} + \sigma_{yrd,op} \quad (C6.3.42)$$

$$\tau_{rd} = \tau_{rd,ip} + \tau_{rd,op} \quad (C6.3.43)$$

where , $\sigma_{rd,ip}, \sigma_{xrd,ip}, \sigma_{yrd,ip}, \tau_{rd,ip}$: stress due to in-plane forces

$\sigma_{rd,op}, \sigma_{xrd,op}, \sigma_{yrd,op}, \tau_{rd,op}$: stress due to out-of-plane forces

In the verification of buckling, it is necessary to fully investigate what effect the out-of-plane forces have on plate buckling. Furthermore, depending on the boundary conditions, increased strength may be predicted due to membrane stress. For this reason, a great deal of care is required depending on the perimeter support conditions.

4) Verification of stiffened plates subject to in-plane forces

The verification of stiffened plates subject to in-plane forces must conform to each requirement for the verification of plates. The term stiffened plate here refers to a flat plate on which stiffeners of sufficient stiffness are arranged with equal spacing. In cases where the stiffeners lack sufficient stiffness or are not arranged with equal spacing, verification of the limit state must be performed using an appropriate structural analysis method.

In the Buckling Design Guidelines [Japan Society of Civil Engineers, 2005], the following method is introduced for verification of the buckling strength of stiffened plates.

The verification equation for a case where the plate is subject to axial forces in two directions is as follows.

$$\left\{ \left(\gamma_i \frac{\sigma_{xu}}{\sigma_{xul}} \right)^2 + \left(\gamma_i \frac{\sigma_{yu}}{\sigma_{yul}} \right)^2 \right\} = 1.0 \quad (\text{C6.3.44})$$

where , σ_{xu} : compressive strength of the stiffened plate
 σ_{xul} : indicates the reference compressive strength of stiffened plate elements, such as from Eq.(C5.3.35)
 σ_{yu} : bending strength of the stiffened plate
 σ_{yul} : indicates the reference bending strength of stiffened plates, such as from Eq.(C5.3.36)

Therefore, the verification for a case where the plate is subject simultaneously to axial force and bending moment is given by the following equations.

$$\gamma_i (N_u^{*p} + M_u^{*q}) \leq 1.0 \quad (\text{C6.3.45})$$

$$N_u^* = \frac{(N/N_y)}{(N_u/N_y)} \quad (\text{C6.3.46})$$

$$M_u^* = \frac{(M/M_y)}{(M_u/M_y)} \quad (\text{C6.3.47})$$

where , N_u^*, M_u^* : strength parameters of axial forces and bending moment
 N_u, M_u : load-carrying capacity for the case where only axial force or bending moment is applied
 N_y, M_y : yield axial force and yield bending moment
 p, q : coefficients

5) Verification of steel pipe subject to a combination of forces in the cross-sectional plane

The local buckling strength of a steel pipe subject to a combination of axial force, bending moment, torsional moment, and shear force in the cross-sectional plane conforms to the verification equation given as Eq.(C6.3.48) when Eqs.(C5.4.2), (C5.4.3), and (C5.4.5) are used as the strength equations.

$$\left\{ \gamma_i \frac{\sigma_{cd}}{\sigma_{cul}} + \gamma_i \frac{\sigma_{bd}}{\sigma_{bul}} + \left(\gamma_i \frac{\tau_d}{\tau_{ul}} \right)^2 \right\} \leq 1.0 \quad (\text{C6.3.48})$$

If Eqs.(C5.4.4) and (C5.4.5) are used, the verification equation shown as Eq.(C6.3.49) is the standard.

$$\left\{ \gamma_i \frac{\sigma_{cd} + \sigma_{bd}}{\sigma_{cbul}} + \left(\gamma_i \frac{\tau_d}{\tau_{ul}} \right)^2 \right\} \leq 1.0 \quad (\text{C6.3.49})$$

where ,

γ_i	: structure factor
σ_{cd}	: compressive stress
σ_{bd}	: bending compressive stress
τ_d	: shear stress
σ_{cul}	: represents compressive strength, from Eq.(C5.4.2)
σ_{bul}	: represents compressive strength, from Eq.(C5.4.3)
σ_{cbul}	: represents compressive strength, from Eq.(C5.4.4)
τ_{ul}	: represents shear strength, from Eq.(C5.4.5)

The bending compressive stress σ_{bd} in Eqs.(C6.3.48) and (C6.3.49) is calculated from $\sigma_{bd} = M_{bd}/W$ using the bending moment acting on the steel pipe cross-section, M_{bd} , and the section modulus, W . This verification equation for a pipe subject to combination loads of this type was obtained from the correlation equation of buckling strength by Schilling.

6.3.2 Verification of Displacement/Deformation Capacity

A member required to have a particular displacement/deformation capacity shall be verified to ensure that the displacement/deformation due to actions will not exceed the limit state.

【 Commentary 】

In statically indeterminate structures, there may be cases where the safety of the overall structure is assured even if the load-carrying capacity of some of the members that make up the structure is exceeded. However, in such cases where the collapse of some members is tolerated as long as overall safety is assured, verification requires consideration of the nonlinear properties of the members. Further, a great deal of care is required with regard to the precision, range of applicability, etc. of the verification method. In cases of this type, it is necessary to confirm that the deformation capacities of members where plastic deformation is tolerated exceed the deformation capacities anticipated in the design. For example, even when calculating the load-carrying capacity in systems with a mechanism that assumes the occurrence of plastic hinges, verification of plastic rotational capacity is required to ensure that the actual structural members will exhibit sufficient plastic hinge functionality.

Furthermore, there are also cases where the load-carrying capacity of a member is verified based on curvature, limit strain, or other measures of deformation instead of cross-sectional force. In these cases, it is necessary to use appropriate verification indices by taking into account the target ultimate state and the properties of the member. In designs where plastic deformation is tolerated, it is necessary to investigate whether structural stability is lost when the displacement or deformation of a member becomes large.

6.3.3 Verification of Stability

- (1) The stability of a structure with regard to rigid-body motion shall be verified for all possible transitional directions and rotations.
- (2) The stability of a structure shall be verified by ensuring that the strongest action acting on the whole structure or part of the structure will not exceed its capacity.

【 Commentary 】

- (1) Stability here refers to the rigid body stability of all or part of the structure under load. Although the verification of the stability of all or part of the structure is closely related to earthquake resistance, the rigid body stability under normally acting loads, such as support forces in the vertical direction and overturning forces on beams, must be investigated separately from earthquake

resistance.

- (2) It is sufficient to verify stability by using the partial-factor method in the same way as in section 6.3.1, "Verification of load-carrying capacity". In selecting the partial factors used in the partial-factor method, it is preferable to carry out the investigation based on failure probabilities. If it is possible to confirm that the failure probabilities are less than the target values, then it is sufficient to use methods that directly evaluate failure probabilities, methods that use the β reliability index, allowable stress design methods, etc.

The following is an example of a verification method based on the partial-factor method [Railway Technical Research Institute, 2000].

- 1) Verification of overturning of bridge beams

In cases where bridge beams are subjected to forces resulting from centrifugal loads, wind loads, etc., the verification shown below is carried out and the structure must be safe against overturning in all situations.

$$\gamma_i \frac{M_{sd}}{M_{rd}} \leq 1.0 \quad (\text{C6.3.50})$$

where , M_{sd} : design overturning moment of the base end of the bridge beam
 M_{rd} : design resistance to overturning of the base end of the bridge beam

Although the horizontal forces acting on a bridge beam include vehicle lateral loads and lateral pressure from vehicle wheels in addition to centrifugal loads, wind loads, and forces due to the effects of earthquake, these effects are not expected to be imposed simultaneously by all vehicles on the bridge beam and also opposite forces can be expected to cancel each other out. Consequently, as long as verification is performed for the effects of wind loads and earthquakes, as a general rule it acceptable to not perform verification of overturning due to vehicle lateral loads and lateral pressure loads from vehicle wheels.

- 2) Verification of uplifting of bridge beams

For continuous beams, cantilevered beams, etc., verification of uplift is performed using the following equation; either an anchor device or a heavy load is added to counteract this force.

$$\gamma_i \frac{(-R_{sd})}{R_{rd}} \leq 1.0 \quad (\text{C6.3.51})$$

where , R_{sd} : design reaction force occurring at the support point
 R_{rd} : design load-carrying capacity of the anchor device or weight of the counterweight

In cases where the spacing between supports in a continuous beam is small and the dead load is small, or where the center span is significantly longer than the end spans, or where a cantilever beam has a long cantilever arm or a long suspended span, an uplifting force may act on the end support points due to the live load and also sometimes due to the dead load. If this kind of uplifting force is not sufficiently suppressed by fitting an anchor device or adding a heavy weight, there is a risk of instability arising and the bridge collapsing, particularly in the case of cantilever beams. Even for continuous beams, if the support point lifts up then it becomes subject to impact loading and excessive stresses even if the bridge does not collapse, and this is not desirable. Although it is intrinsically undesirable to have span ratios that lead to this kind of uplifting force, there are cases where the positions of support points cannot be adjusted for reasons such as the surrounding environment. To verify cases where an uplifting force may act on the support points in this way, care is required because it is not thought to be sufficiently safe to simply consider the normal live load in the worst position in terms of member stress.

6.4 Verification of Structural Safety by Nonlinear Structural Analysis

Structural safety may be verified by evaluating the ultimate load-carrying capacity of the whole structure by nonlinear structural analysis.

【Commentary】

In the verification of structural safety described in section 6.3, structural analysis is primarily used for the purpose of calculating response values within the elastic range, while load-carrying capacities are set based on load-carrying capacity curves at the member level based on previous experimental results, etc. This means that safety is assured by taking account of the effects on load-carrying capacity of imperfection, nonlinearity, and so on. At present, fundamental theories of structural analysis develop and the more widespread availability of computers able to numerically handle the calculations, relatively rational design methods that offer the designer flexible nonlinear structural analysis even from the point of view of performance design are expected to be introduced aggressively. In verification based on nonlinear structural analysis, the use of artificial concepts such as effective buckling length and the evaluation of boundary conditions between members become unnecessary. Furthermore, the methods of nonlinear structural analysis can be applied to designing redundancy in the overall structure, opening up the possibility of creating new structural modes. However, it is necessary to: ① consider the analytical model configuration, such as how to set initial imperfections and residual stress, and the element types and partitioning; ② conform to the initial soundness as regulated by construction codes; ③ specify the limit state; and ④ specify appropriate partial factors. Furthermore, it is necessary to differentiate between two safety limit states when specifying the limit state. The first of these limit states means that the design does not tolerate additional deformation after buckling; this is verified by taking the initial buckling (buckling of the overall structure, buckling of constituent components, or local buckling of fragments) as the safety limit. The second limit state is verified by taking the load-carrying capacity or the deformation capacity of the overall structure as the safety limit. This design method provides assurance of overall load-carrying capacity or deformation properties in cases where the structure is statically indeterminate and some strength after initial buckling can be anticipated, as well as in cases where stiffness is expected to change and the forces are expected to be redistributed due to yielding without buckling occurring.

The following is an example of verification by elasto-plastic finite displacement analysis based on Ultimate Strength and Design of Steel Structures [Japan Society of Civil Engineers, 1994].

< Verification method with load-carrying capacity or deformation performance of the overall structure as the safety limit >

For verification taking the load-carrying capacity or deformation performance of the overall structure as the safety limit, verification can be performed by a method that uses load parameters, given as Eq.(C6.4.1) that represents overall behavior, or by deflection given as Eq.(C6.4.2).

$$\gamma_i \gamma_a \gamma_b \frac{1}{\alpha_u} \leq 1.0 \quad (\text{C6.4.1})$$

$$\gamma_i \gamma_a \frac{\delta_u}{\delta_{rd}} \leq 1.0 \quad (\text{C6.4.2})$$

where , γ_i : structure factor
 γ_a : structure analysis factor
 γ_b : member factor (however, here it is the safety factor in consideration of the uncertainty of the load-carrying capacity of the overall structure)

- α_u : load parameter in the safety limit state. This refers to the load parameter when the structure reaches the safety limit state during elasto-plastic finite displacement analysis and incrementing the load vector $\alpha \sum \gamma_{fi} L_i$ (α : load parameter).
- γ_{fi} : load factor
- L_i : design load vector
- δ_u : maximum deflection in safety limit state found by elasto-plastic finite displacement analysis
- δ_{rd} : critical value of deflection in the safety limit state (γ_b is included in this)

6.5 Verification of Structural Safety through Experiment

Structural safety may be verified by evaluating the effect of actions such as cross-sectional forces, stress and displacement, or load-carrying capacity experimentally.

【Commentary】

Although verification of structural safety through experiment is a method that was originally used implicitly in design standards, in this code it is explicitly designated as a verification method. Experiments for the verification of structural safety are of two types depending on the goal: those that determine the resistance value and those that determine the response value. The former experiments are used as a means to specify the load-carrying capacity of structural members or the overall structure. This method is mainly used in situations where there the performance record, in the form of the load-carrying capacity curve for a new structural form, is insufficient and in cases where a relatively rational design is desired. Furthermore, the resistance value also includes the limit wind speed at which aerodynamically unstable vibrations arise. On the other hand, an example of the latter is the setting of the wind load and the loading effects for a structure that has a complex shape unsuitable for specifying in terms of a wind force coefficient.

References in Chapter 6

- Japan Society of Civil Engineers (1994) : Ultimate Strength and Design of Steel Structures, Steel Structure Series 6 .
- Japan Society of Civil Engineers (1997) : Design Code for Steel Structures, PART A; Structures in General.
- Railway Technical Research Institute(2000) :Design Standards for Railway Structures and Commentary, Steel and Composite Structures .
- Honshu-Shikoku Bridge Expressway Company Limited(2001) : Lecture for Wind-resistance Design Code.
- Japan Road Association (2002) : Specifications for Highway Bridges and Commentary, I Common Specifications Volume, II Steel Highway Bridges Volume.
- Japanese Society of Steel Construction(2004) : International Harmonization Guideline of Design Standards for Steel Structures(Steel Bridges), JSS IV 06-2004.
- Japan Society of Civil Engineers (2005) : Buckling Design Guidelines, Ver.2 [2005 Version].
- Japan Road Association(2005) : Wind-resistant Design Manual for Highway Bridges.
- ISO(1998) : ISO2394 International Standard, General Principles on Reliability for Structures” .

Chapter 7 Required Serviceability Performance and Verification

7.1 General

- (1) Steel and composite structures must remain serviceable under the actions specified in Chapter 2 throughout their in-service period.
- (2) Performance items related to serviceability include vehicle operating performance, train operating performance, and pedestrian comfort according to how the structure is utilized.
- (3) Serviceability shall be verified for the limit state established for each performance item by setting proper verification indices representative of the performance item, except in cases where use of the structure is restricted or where the structure is rendered unusable due to meteorological conditions or earthquakes.

【 Commentary 】

Steel and composite structures must remain serviceable under the actions specified in Chapter 2 throughout their in-service period except in cases where use of the structure is restricted or where the structure is rendered unusable due to meteorological conditions or earthquakes.

Performance items related to serviceability include vehicle operating performance, train operating performance, and pedestrian comfort according to how the structure is utilized.

Fatigue resistance, corrosion resistance, resistance against material deterioration, and maintainability should be considered as Durability in Chapter 8.

7.2 Required Performance for Serviceability

7.2.1 Vehicle operating performance

Steel and composite structures shall be designed to provide safe passage of vehicles and to avoid undesirable psychological reactions among passengers in vehicles under the expected actions and meteorological conditions.

【 Commentary 】

This section establishes the required performance with respect to vehicle operation for road bridges so as to ensure that vehicles can use the structure safely and to avoid undesirable psychological reactions among passengers under expected actions (permanent actions such as the dead load as well as variable actions such as the live load and wind) and expected meteorological conditions.

The vehicle operating performance requirements are shown in Table C7.2.1. Vehicle operating performance is specified for ordinary conditions, rain, strong winds, and winter conditions.

Under ordinary conditions, undesirable psychological reactions among passengers in vehicles are to be avoided. Items to be verified are the soundness of the road, the stiffness of the road, and operating visibility.

Vehicle operating performance in rain, strong winds, and under winter conditions is related to safety performance. The performance requirements to be verified in these cases take into consideration roadway drainage, the incidence of strong winds, measures taken to mitigate the effects of strong winds, and road surface freezing. Vehicle operating performance also includes design to maintain the

Table C7.2.1 Performance requirements for vehicle operation

Performance requirements		Verification indexes
Vehicle operating performance	Vehicle operating performance under ordinary conditions	Soundness of the road
		Stiffness of the road
		Operating visibility
	Vehicle operating performance under rain conditions	Taking into consideration roadway drainage
Vehicle operating performance under strong winds conditions	Taking into consideration the incidence of strong winds, measures taken to mitigate the effects of strong winds	
Vehicle operating performance under winter conditions	Taking into consideration road surface freezing	

functionality, such as by securing the expansion gap and girder gap, in Level 1 earthquakes.V

The need to consider vehicle operating performance in dense fog, snow, and drifting snow is minimal at the design phase, so it is not considered here. However, after considering the climate characteristics of the region and details of the structure, performance requirements should be established if necessary.

Then it is necessary to consider the action, meteorological conditions, and degree of importance of the structure, establishing the serviceability performance level appropriately. Performance levels are shown in Table C7.2.2.

Table C7.2.2 Example of performance requirements for vehicle operation

Level	Loading conditions and weather conditions	Performance requirement	Details
Level 1	<ul style="list-style-type: none"> • Live load during design service life • Weather condition 1 (low wind velocity and light rainfall) 	Vehicle operating performance under ordinary conditions	Providing smooth passage of vehicle, Ensuring the comfortable of passengers.
Level 2	<ul style="list-style-type: none"> • Weather condition 2 (high wind velocity and rainfall exceeding a certain level) 	Vehicle operating performance under extreme conditions	Providing safety passage of vehicle.

Since vehicle operating performance is influenced by meteorological conditions including wind and rain, it is appropriate to establish performance levels according to meteorological conditions. Weather Condition 1 in Table C7.2.2 represents meteorological conditions such as wind velocity, rainfall, or road surface freezing that have no influence on vehicle operation; the expected performance must be satisfied in this case. Weather Condition 2 represents conditions that influence vehicle operating performance and it is reasonable to allow some drop in expected vehicle operating performance; for example, a speed restriction may be imposed on a toll road.

It may be appropriate to satisfy Condition 1 performance even with Weather Condition 2 according to the purpose of the structure and its degree of importance.

7.2.2 Train operating performance

Steel and composite structures carrying railway tracks shall be designed to provide smooth passage of trains and to avoid undesirable psychological reactions among train passengers under

the expected actions and meteorological conditions.

【Commentary】

Steel and composite structures that carry trains should be verified for the operating performance of trains under normal running conditions as well as for the passenger ride comfort, as provided for by [Railway Technical Research Institute, 2000] and [Railway Technical Research Institute, 2006]. This verification of train operating performance aims to ensure that the railway vehicles run smoothly under the usual actions (that is, the permanent actions of the dead load, etc. and the variable actions of train loading and impact loading, etc.). The verification of ride comfort aims to secure passenger comfort with respect to vehicle vibrations induced by trains operating on the structure.

The performance requirements for train operating performance are given in Table C7.2.3. In this specification, there are two performance requirements each for train running performance under ordinary conditions and ride comfort.

Table C7.2.3 Performance requirements for train operation

Performance requirement		Verification indexes
Train operating performance	Train running performance under ordinary conditions	Structure vibrations
		Displacement/deformation of structure
	Ride comfort	Structure vibrations
		Displacement/deformation of structure

In [Railway Technical Research Institute, 2006], train running performance under ordinary conditions is one of the performance requirements for safety while ride comfort is one of the performance requirements for serviceability. In this specification, because safety relates to structural safety and public safety, train running performance under ordinary conditions is included as one of the serviceability performance requirements and is considered one of the performance requirements that ensures railway passenger comfort. For train running performance under seismic loading, refer to [Railway Technical Research Institute, 2006].

The example of required performance levels for train operation is shown in Table C7.2.4. No performance requirements for train operating performance are provided for extreme weather conditions such as heavy rain and strong winds. The reason for this is that countermeasures to restrict service, such as by stopping train operation, limiting speed, etc. are required under extreme weather conditions, so there is no need to consider extreme weather when designing railway structures. For this reason, only one level of requirements for train operating performance is provided.

Table C7.2.4 Example of performance requirements for train operation

Level	Loading conditions and weather conditions	Performance items	Contents
Level 1	• Live load during design service life	Train running performance under ordinary conditions.	Providing smooth passage of railway vehicles over the structure
	• Weather Condition 1 (low wind velocity and light rainfall)	Ride comfort	Ensuring the comfort of passengers with respect to railway vehicle vibrations while passing over the structure.

7.2.3 Pedestrian comfort

Structures shall be designed to avoid undesirable psychological reactions among pedestrians under the expected actions and meteorological conditions.

It is recommended that structures be designed to provide safety and accessibility for all users, including the elderly and handicapped.

【Commentary】

This specification provides, as a walking comfort performance requirement for structures designed for use by pedestrians, that pedestrian unease and annoyance should be maintained to a certain level. At the same time, the idea of the universal design should be incorporated as far as possible so as to achieve structures that are easily accessible structures for all, including the elderly and handicapped. The check items for walking comfort performance are given in Table C7.2.5.

Table C7.2.5 Check items for walking comfort performance

Performance requirement		Check item
Walking comfort	Walking comfort under normal conditions	Condition of pavement
		Vibration during walking
		Visibility during walking

A walking comfort performance level can also be specified according to the weather conditions.

Table C7.2.6 Example of performance requirement for walking comfort

Level	Loading condition and weather conditions	Performance requirement	Details
Level 1	<ul style="list-style-type: none"> • Live load during the design service life • Weather condition 1 (low wind velocity and light rainfall) 	Walking comfort under ordinary conditions	No unease or annoyance felt by pedestrians.
Level 2	<ul style="list-style-type: none"> • Weather condition 2 (high wind velocity and rainfall exceeding a certain level) 	Walking comfort under extreme conditions	Pedestrian safety is assumed and there is a tolerable level of vibration, unease and annoyance.

Under weather condition 1, as shown in Table C7.2.6, walking comfort must not be influenced by weather conditions, such as wind velocity, rainfall and pavement surface freezing. Ordinary walking comfort should be secured under these conditions. For weather condition 2, walking comfort is influenced by the weather. It is reasonable to accept certain impairment of ordinary walking comfort. Walking comfort under extreme conditions such as storms, strong winds or in winter can also be considered.

Depending on the purpose and importance of the structure, weather level 1 conditions can be satisfied even under weather condition 2 by special arrangement. For example, walking comfort during severe storms that would normally make it impossible to walk can be assured by the introduction of wind breaks. Similarly, snow shelters or snow melting equipment may be introduced to maintain walking comfort.

7.2.4 Other Considerations for Users

Non-structural aspects of structures, including aesthetics and water-tightness, shall also be designed to avoid undesirable psychological reactions among users under the expected actions and meteorological conditions.

【 Commentary 】

Other considerations should be paid to users so as to avoid harmful or uncomfortable effects on the direct users of a structure in addition to verifying vehicle operating performance, train running performance, and pedestrian comfort. Excessive deformation of a structure or deterioration of its appearance should not be allowed to make users feel uneasy or uncomfortable. Generally, users will have undesirable psychological reactions to structures if the cracking or discoloration of the surface of a structure is greater than a certain limit. Therefore, measures to prevent a deteriorated appearance should be provided in advance by examining the possible influence on users.

Rainwater infiltration through unacceptably large cracks or between joints in steel components may cause water leakage. Generally the influence of cracks on the concrete surface, joints in steel plates, and boundaries between concrete and steel must be examined for water-tightness.

7.3 Verification of Serviceability

7.3.1 Verification of vehicle operating performance

Vehicle operating performance under ordinary, wet, windy, and winter conditions shall be verified in principle as specified below.

(1) Verification of vehicle operating performance under ordinary conditions

Performance requirements for vehicle operating performance under ordinary conditions shall be road surface soundness, stiffness, and operating visibility. Assessments shall be as follows.

Road surface soundness: Road surface flatness and friction coefficient shall meet a specified criterion for each item.

Stiffness: Deformation due to live load shall not be greater than a specified criterion.

Operating visibility: Visibility shall be the minimum required for the design velocity.

(2) Verification of vehicle operating performance under wet conditions

Vehicle operating performance under wet conditions shall be verified by confirming that the surface drainage system has a capacity be greater than a predetermined level of rainfall.

(3) Verification of vehicle operating performance under windy conditions

Vehicle operating performance under windy conditions shall be verified by confirming that the wind velocity over the structure is less than the specified criterion or that a speed limit dependent on wind velocity is imposed.

(4) Verification of vehicle operating performance under winter conditions Vehicle operating performance under winter conditions shall be verified by confirming that the floor slab selected is less prone to icing or that anti-freezing measures are adopted.

【 Commentary 】

Vehicle operating performance under ordinary expected conditions, in wet conditions, in windy conditions, and in winter conditions is verified for each suitable verification index. Examples of verification items and verification indices for required vehicle operating performance are shown in Table C7.3.1.

Table C 7.3.1 Check items and examples of check indices for vehicle operating performance requirements

Performance requirement		Check item	Example of index
Vehicle operation	vehicle operation under ordinary conditions	Soundness of the road	Road unevenness, Friction coefficient
		Stiffness of the road	Deflection
		Operating visibility	Forward visibility
	vehicle operation under rain conditions	taking into consideration roadway drainage,	Roadway drainage performance
	vehicle operation under strong winds conditions	taking into consideration of strong winds	Incidence of strong winds, measures taken to mitigate the effects of strong winds,(Speed restriction, shielding etc)
vehicle operation under winter conditions	taking into consideration road surface freezing	Structure of uneasily freezing, Measures of surface freezing	

(1) Vehicle operating performance under ordinary conditions is verified in terms of the soundness of the road, the stiffness of the road, and visibility for vehicle operation using suitable verification indices.

1) Road surface soundness

Road surface soundness is represented by road unevenness, pavement cracking, differential expansion, and the friction coefficient between tire and road. Poor road surface soundness may result in vibration or other vehicle noise, loss of safety, and poor passenger comfort. If the verification indices satisfy the specified criteria, vehicle operating performance in terms of safety and passenger comfort is secured. Ideally, the criteria should be set based on test runs, etc.

The friction coefficient between the tire and road surface influences on vehicle operating performance. There are two coefficients related to friction; one is the longitudinal skid resistance coefficient and the other is the lateral force coefficient. According to the latest specifications for stopping distance under braking by the [Japan Road Association (1983)], the longitudinal skid resistance coefficient must be from 0.29 to 0.44 assuming moist conditions. On the other hand, the line of curved sections of road is prescribed according to the design speed in consideration of a lateral force coefficient from 0.1 to 0.15.

2) Stiffness

If secondary stress leads to damage that has not been anticipated and a safety performance problem arises because of excessive deflection or vibration, the required performance of the bridge as given by the [Japan Road Association (2002)] might not be met.

Table C7.3.2 Design limit value of girder deflection (m)

Type of girder		Simple girder and continuous girder	Cantilever of Gerber girder
type of bridge			
Steel girder	Steel girder of slab	$L \leq 10$	$L/2000$
		$10 < L \leq 40$	$\frac{L}{20000/L}$
		$40 < L$	$L/500$
	Steel girder of other type slab	$L/500$	$L/300$
Suspension bridge		$L/350$	
Cable stayed bridge		$L/400$	
Other type bridge		$L/600$	$L/400$

By limiting the deflection allowed under a live load with no impact, the necessary stiffness can be secured for the structure. It is necessary to establish a proper criterion for live-load deflection to be used in verifying ordinary vehicle operating performance. The deflection criterion is established according to the type and scale of the targeted structure and using the design conditions. Use the design criteria of a similar structure, if not refer to examinations. For example, the deflection criterion shown in Table C7.3.2 is prescribed by the [Japan Road Association (2002)].

3) Operating visibility

It is necessary to be aware of an obstacle (or oncoming vehicle) ahead of the vehicle and brake to a stop so as to avoid a collision (i.e. within the vehicle stopping distance) or avoid the obstacle with adequate forward visibility. If forward visibility provided by the [Japan Road Association, 2004] is satisfied, the safety of vehicle operation may be secured.

- (2) To secure vehicle operating performance in wet conditions, it is necessary to install drains such that rain water does not collect on the road. If standing water does accumulate on the road, then vehicle operating safety performance cannot be secured and vehicle hydroplaning can easily occur. Verification of vehicle operating performance in wet conditions means calculating the rate of assumed rainfall for the region (rainfall intensity). Further, it is necessary to verify the drainage capacity of the drain design, the drainpipe diameter, and the drain inclination, etc.

Drain performance might deteriorate with sediment buildup, so it is necessary to verify drain performance on the assumption that sediment is managed to a certain level.

- (3) Vehicle operating performance can be reduced under windy conditions, making slower driving necessary. Windy conditions under which driving are permitted may be defined, for example, as the range of wind velocities from 10m/s to 25m/s. Then a storm warning may be given for wind velocities of 25m/s or more and driving is then restricted [Tajima,1994].

Phenomena that can influence vehicle operating performance under windy conditions include the following:

- a. Wind-induced girder vibration ,
- b. Wind-induced structural member vibration ,
- c. Sudden change in velocity of wind impinging the structure.

Wind-induced girder vibration can influence vehicle operating performance directly, so it is necessary to control it below a certain limit. It should be verified that acceleration, based on vibration amplitude in wind tunnel tests [Japan Road Association 1991, Honshu-Shikoku Bridge 2001], does not exceed criteria established from vehicle operating performance or unpleasantness induced in users.

Wind-induced vibration of structural members also influences the safety and fatigue resistance of the members, while the anxiety it may cause users cannot be disregarded. For this reason, it is necessary to limit the amplitude within a cert over. It is necessary to ensure that wind velocity fluctuations remain within the range where driving safety can be secured. Verification means confirming that fluctuations from a certain range of mean wind velocities are below the criterion for safe vehicle operation as set by analysis or by driving simulation. Quantitative evaluation of wind velocity fluctuations may be based on wind tunnel tests or numerical fluid analysis combined with measurements from a similar case. If this verification shows that safety performance is not achieved, an effective countermeasure to obstruct the wind and ease velocity fluctuations is to install windshields or similar. However, such shielding may increase the wind loading and cause deterioration in wind performance, so it is necessary to carry out an appropriate examination.

- (4) A frozen road surface in winter can reduce the resistance to sliding between tire and road surface, thereby affecting vehicle operating performance.

In comparison with a concrete slab deck, a steel plate deck is prone to condensation freezing and snow compaction, so careful consideration of the type of slab is necessary in regions where

road surface freezing occurs.

Depending on the intended purpose and degree of importance of the structure, required performance may be maintained by preventing road surface freezing and snow accumulation. Possible measures to achieve this are the spreading of anti-freeze materials, road heating, and pipe melting of snow. However, if anti-freeze materials are used, the danger of promoting rust and having a detrimental influence on the surrounding environment must be considered. In the future, alternative measures deriving from research into controlling road freezing [Shigenobu Miyamoto, 1998] by building-in thermal storage materials, etc. are expected.

7.3.2 Verification of train operating performance

The train operating performance and ride comfort of steel and composite structures that carry railway tracks shall, in principle, be verified under normal conditions as specified below.

(1) Verification of train operating performance under normal conditions

Train operating performance in ordinary conditions shall generally be verified by confirming that structure displacement as determined through static analysis is less than a criterion determined from the viewpoint of an operating safety limit.

(2) Verification of riding comfort

Riding comfort in ordinary conditions shall generally be verified by confirming that structure displacement as determined through static analysis is less than a criterion determined from the viewpoint of a riding comfort limit.

【Commentary】

- (1) Though there are various definitions relating to train running performance, this specification states that train running performance under ordinary conditions should be verified by confirming that the train wheels pass smoothly and safely over the rails.

It is necessary to confirm that the response of all vehicle wheels satisfies the requirements for derailment quotient, wheel load reduction ratio, and lateral pressure. The desired method of carrying out this verification is to use dynamic interaction analysis in which both railway vehicles and the structure are modeled.

However, such dynamic interaction analysis is complex in terms of structural design. A convenient alternative has been to carry out the verification using values of structural displacement and deformation obtained from static analysis. When using this method, it should be checked that deflection of the girder caused by train loading (at assumed maximum loading) and the impact load is below the limit value of deflection determined by train running performance under ordinary conditions. The limit value of girder deflection as provided for by [Railway Technical Research Institute, 2006] is shown in Table C7.3.3 as the condition that the wheel load reduction ratio is 0.37 or less.

- (2) Various definitions concerning ride comfort have been proposed. In general, ride comfort is classified as overall ride comfort during some time period (ride comfort over a section) and momentary ride comfort at an individual point (point ride comfort). The latter, point ride comfort, is generally used to evaluate ride comfort on railway bridges. The verification index used should be the acceleration response of the train vehicle body. That is, it is necessary to confirm that the maximum acceleration among all vehicles making up a train satisfies the ride comfort limit value provided in [Railway Technical Research Institute, 2006]. The method of carrying out this verification of ride comfort should ideally be a dynamic interaction analysis that models both the railway vehicles and the structure.

However, such dynamic interaction analysis is complex in terms of structural design. A con-

Table C7.3.3 Design limit value of girder deflection determined by train running performance under ordinary conditions

Train types	Number of spans	Max. speed (km/h)	Span L_b (m)		
			~ 40	40 ~ 60	70 ~
Shinkansen	Single	260	$L_b/700$		
		300	$L_b/900$		
		360	$L_b/1100$		
	Multiple	260	$L_b/1200$	$L_b/1400$	
		300	$L_b/1500$	$L_b/1700$	
		360	$L_b/1900$	$L_b/2000$	
Electric cars/ diesel cars	Single	130	$L_b/500$		
		160	$L_b/500$		
	Multiple	130	$L_b/500$		
		160	$L_b/600$		
Locomotive	Single	130	$L_b/400$		
	Multiple	130	$L_b/600$	$L_b/700$	

venient alternative has been to carry out the verification using values of structural displacement obtained from static analysis. When using this method, it should be checked that deflection of the girder caused by train loading (under normal service conditions) and the impact load is below the limit value of deflection determined by the limit state of ride comfort. The limit value of girder deflection, on condition that the ride comfort coefficient as provided in [ride comfort specification in previous Japan national railway (JNR)] is 1.5Hz or over and the maximum acceleration of each vehicle body is 2.0m/sec^2 or less, is prescribed as shown in Table C7.3.4 according to [Railway Technical Research Institute, 2006].

Where frequent occurrence of high winds is expected, such as in the case of sea and river crossings, measures to mitigate the wind such as the installation of windbreak fencing should be considered even though train operating performance is provided only for Level 1 weather conditions.

Table C7.3.4 Design limit value of girder deflection determined by ride comfort

Train types	Number of spans	Max. speed (km/h)	Span L_b (m)					
			~ 20	~ 30	~ 40	~ 50	~ 60	70 ~
Shinkansen	Single	260	$L_b/2200$	$L_b/1700$	$L_b/1200$	$L_b/1000$		
		300	$L_b/2800$	$L_b/2000$	$L_b/1700$	$L_b/1300$	$L_b/1100$	
		360	$L_b/3500$	$L_b/3000$	$L_b/2200$	$L_b/1800$	$L_b/1500$	
	Multiple	260	$L_b/2200$	$L_b/1700$				
		300	$L_b/2800$	$L_b/2000$				
		360	$L_b/3500$	$L_b/2800$	$L_b/2200$			
Electric cars/ diesel cars	Single	130	$L_b/500$					
		160	$L_b/500$					
	Multiple	130	$L_b/900$				$L_b/700$	
		160	$L_b/1100$				$L_b/800$	
Locomotive	Single	130	$L_b/500$					
	Multiple	130	$L_b/900$				$L_b/700$	

7.3.3 Verification of pedestrian comfort

Pedestrian comfort under ordinary conditions shall, in principle, be verified in terms of pavement soundness, walking-induced vibration, and visibility as specified below.

(1) Verification of pavement soundness

Pavement soundness shall be verified by confirming that flatness is assured, slip resistance coefficient is within a range of an assessment index, and gradient is not greater than a specified criterion.

(2) Verification of walking-induced vibration

Walking-induced vibration shall be verified by confirming that vibration velocity and acceleration, which may affect walking comfort, are not greater than criteria specified for the natural frequencies of the structure or that the natural frequencies are outside the range of resonance.

(3) Verification of visibility

Pedestrian visibility shall be verified by confirming that visibility is not less than a specified criterion and that there is a large variation in brightness to allow discrimination of guidance block edges and stairway steps.

【Commentary】

Pavement surface soundness, walking-induced vibration and visibility should be checked against the appropriate indices. In Table C7.3.5, check items and examples of indices for walking comfort performance requirements are shown.

**Table C7.3.5 Check items and example of check indices
for walking comfort performance requirements**

Performance requirement		Check item	Example of index
Walking comfort	Walking comfort under normal conditions	Soundness of pavement surface	Flatness of surface, slip resistance coefficient, gradient of surface
		Walking-induced vibration	Velocity, acceleration, natural frequencies
		Visibility while walking	Forward visibility, brightness of pavement surface, brightness differential of steps, guide blocks and environs.

- (1) The soundness of the pavement surface can be expressed in terms of flatness, slip resistance coefficient, and gradient. Flatness can be represented by the surface smoothness, cracks in the pavement, and the flatness of expansion joints. The flatness of structure surfaces must be secured so that walking comfort is assured and pedestrians do not suffer any unease.

It should be checked that the slip resistance coefficient of the pavement is within the range of assessment indices that assure serviceability. This coefficient is especially important because it influences not only walking serviceability but also safety. The slip resistance coefficient of the pavement surface should be experimentally determined using the CSR index as measured using an O-Y · PSM (O-Y · Pull Slip Meter) or using the BPN index as measured by a BPST (British Portable Skid Resistance Tester).

The road surface gradient should be checked for compliance with limit values for longitudinal gradient and superelevation. For stairway, ramp, or gradient with steps, the limit value of longitudinal gradient should be determined in consideration of users and its serviceability for them: pedestrians, bicycles, baby carriages, wheelchairs, etc. In [Japan Road Association, 1979],

it is specified that the standard value for a stairway gradient is 50%, while the gradient of a ramp or a gradient with steps should not exceed 12% and 25%, respectively. It is desirable to reduce the gradient of ramps by introducing the idea of universal design and taking into consideration the elderly and handicapped. For example, in [Japan Road Association, 1979], it is shown that the maximum gradient that a wheelchair user can climb unaided is 8% while bicycles can easily climb a slope of up to 5%. It is also specified that the introduction of elevators or escalators should be considered when necessary.

- (2) Pedestrians may feel uncomfortable if vibrations are induced by walking, so it must be checked that the vibration responses of a structure, i.e. the response velocity or acceleration, are within limit values and that the natural frequencies are not within the resonance range.

Structure vibrations may be induced by vehicles, pedestrians, or the wind. The limit values for these vibrations should be values determined through experiments that focus on the human perception of vibrations. Vibration velocity or acceleration due to walking should be evaluated based on a dynamic analysis of the structure using a moving vehicle model in the case of road bridges and with a moving pedestrian model for pedestrian bridges, because vibration is affected by structural type, loading conditions, and their interactions. For wind-induced vibration, results obtained in wind tunnel tests can be utilized to evaluate walking comfort.

However, this type of dynamic analysis or wind tunnel testing might be too time-consuming for conventional design work. If simplified verification based on experiments or analysis is proposed, a simplified method may be adopted.

1) Running-induced vertical vibrations For limit values and an evaluation index, refer to [Japan Road Association, 1979; BSI, 1978].

In [Japan Road Association, 1979], it is specified that main girder vibrations caused by the live load shall not cause unease among pedestrians. It also illustrates that, to avoid resonance with walking pedestrians at a frequency of around 2 Hz, the first natural frequency of the structure should fall outside the range 1.5 to 2.3 Hz. Furthermore, to avoid feelings of unease among pedestrians due to bending vibration even when this resonance range has been avoided, it is explained that it is desirable to reduce the maximum acceleration to below 100 gal for the vibration caused by the 2 Hz periodical excitation under normal live loading of one person per square meter.

According to a research conducted by [Obata, et al., 1996], pedestrians can also feel uneasy at 4 Hz, which corresponds to the half resonance condition with 2 Hz excitation. This is also true for a natural frequency of around 3 Hz in the case of pedestrian bridges over which joggers often pass. It is desirable to decide on suitable check indices considering local conditions and the expected users.

In [BSI, 1978], acceleration is calculated by a method proposed by Blanchard, et al. in 1977 and it is specified that this acceleration must not exceed the limit value. In Blanchard's calculation, the excitation force per pedestrian leg can be represented by a sinusoidal curve expressed as $F = 180 \sin(2\pi ft)$ (N) moves at a speed of $V = 0.9f$ (m/s). The maximum acceleration can then be obtained as shown in Eq.(C7.3.1).

$$\text{Maximum acceleration} \quad a = (2\pi f_1)^2 w K \psi \quad (\text{m/s}^2) \quad (\text{C7.3.1})$$

- Where ,
- f_1 : First natural frequency of the bridge (Hz)
 - f : Walking frequency, same as natural frequency of bridge (Hz)
 - w : Maximum static deflection of superstructure when loaded with one pedestrian (700N) (m)
 - K : Shape factor corresponds to structural type
 - ψ : Dynamic response coefficient with damping factor h as parameter

It is proposed that the maximum acceleration obtained by the above equation should not exceed the acceleration limit value $0.5\sqrt{f_1}$ (m/s²), which is expressed as a function of the natural frequency of the superstructure.

2) Running-induced horizontal vibration

There are no particular specifications in [Japan Road Association, 1979] and [Japan Construction Engineers' Association, 1984] for the horizontal vibrations of pedestrian bridges. So far, no special consideration has been given to horizontal vibration in design. However, the influence of horizontal vibrations under the influence of a moving crowd of people cannot be ignored for bridge types such as cable-stayed bridges and suspended deck bridges. In checking horizontal vibrations, the study [Yoneda, 2003] is a good reference.

- (3) Pedestrian visibility is considered one of the required performance factors for comfortable usage of a structure. It may be reasonable to specify the performance requirement for pedestrian visibility according to the purpose, location, and importance of the structure. In verifying pedestrian visibility, the foreground visibility and road surface brightness should satisfy the limit value specified for the structure. Refer to [Japan Road Association, 1979] or [Japan Road Association, 1981] for the checking of road surface brightness.

7.3.4 Verification for Other Considerations

Other considerations for users shall be verified in principle using appropriate indices and related criteria.

【Commentary】

The appearance of a concrete-covered structure should not suffer deterioration by surface cracking. The limit value of crack width with respect to appearance depends on the type of structure and the surrounding environment. In [Railway Technical Research Institute, 2002], a general limit value of around 0.3 mm is proposed based on historical performance and experience. Further, appropriate measures must be provided for in the case of visually significant structures in accordance with the surface texture of the steel and concrete. It is important to pay attention to steel coatings and concrete surface finish as well as preventing discoloration and the accumulation of dust on the surface of members.

The water-tightness of a structure should not be compromised by cracks on the concrete surface. Waterproofing work must be considered when good water-tightness is required of a structure. The limit value of crack width for water-tightness depends on the required level of water-tightness and the type of cross-sectional forces that dominate. As an example, [Japan Society of Civil Engineers, 2002] proposes a general limit value of less than 0.1~0.2mm.

References in Chapter 7

- Japan Road Association(1979) : Technical Standards for Pedestrian Overpass.
 Japan Road Association(1981) : Technical Standards for Structure of Roadway Lighting.
 Japan Construction Engineers' Association, 1984 : Guidebook for Pedestrian Bridge.
 Japan Road Association(1991) : Wind-resistant Design Manual for Highway Bridges.
 Tajima,T.(1994) : Influence of Lateral Wind on Driving on Offshore Bridge, Honshu-Shikoku Bridge Expressway Company Technical Report, Vol.18, No.71, pp.9-18.
 Obata, T., Hayashikawa, T. and Satoh, K.(1996) : Study on Vibration Serviceability Limit State of Pedestrian Brides based on Human Vibration Sensibility, Journal of Structural Engineering/Earthquake Engineering, No.537/I-35, pp.217-231.
 Japan Society of Civil Engineers (1997) : Design Code for Steel Structures, PART A; Structures in General.
 Miyamoto S., Murota M.(1998) : Road Icing on Steel Deck Bridges and its Control by Phase Change Material,

- Bridge and Foundation Engineering, No.6, pp.25-31.
- Railway Technical Research Institute(2000) : Design Standard for Railway Structures and Commentary, Steel and Composite Structures .
- Japanese Society of Steel Construction(2001) : Guidelines for Performance-Based Design of Civil Engineering Steel Structures.
- Honshu-Shikoku Bridge Expressway Company Limited(2001) : Lecture for Wind-Resistance Design Code.
- Railway Technical Research Institute(2002) : Design Standards for Railway Structures and Commentary, Steel and Composite Structures .
- Japan Society of Civil Engineers (2002b) : Guidelines for Performance Verification of Hybrid Structures (tentative) .
- Japan Road Association (2002) : Specifications for Highway Bridges and Commentary, II Steel Highway Bridges Volume .
- Yoneda, M.(2003) : A Simplified Method to Evaluate Maximum Lateral Response of Pedestrian Bridges due to Synchronized Walking by Pedestrians, Journal of structural engineering, Vol.49A, pp.263-272.
- Japan Road Association (2004) : Practical Guide and Implementation of Road Construction Ordinance .
- Railway Technical Research Institute(2006) : Design Standard for Railway Structures and Commentary, Displacement Limits .
- Blanchard, J.B.I.Davis and J. W.Smith(1977) : Design criteria and analysis for dynamic loading of foot-bridges, UK. TRRL Report SR.275 .
- BSI(1978) : Steel, Concrete and Composite Bridges, Part2. Specification for Loads, 7.1.5 Vibration Serviceability, BS 5400 .

Chapter 8 Required Durability Performance and Verification

8.1 General

- (1) Steel and composite structures must continuously maintain the required level of performance under the expected actions throughout the design working life.
- (2) Performance verification items related to the durability of steel and composite structures include fatigue resistance, corrosion resistance, resistance to material deterioration, and maintainability.
- (3) Verification of fatigue resistance, corrosion resistance, resistance to material deterioration, and maintainability must involve the setting of adequate indices representing performance item and verification of the limit state established for each item.

【 Commentary 】

There is a time-dependent deterioration of the performance of steel and composite structures due to the actions to which they are exposed. The durability of a structure is defined as its or its members' ability to resist this performance deterioration. In other words, ensuring that performance is maintained at the required level (in terms of safety, serviceability, etc.) throughout the design working life under the assumed actions should ensure that the durability performance is satisfied.

Of the factors that lead to performance deterioration over the design working life of a structure, one is the damage caused by mechanical deterioration (fatigue) and another is the damage caused by electro-chemical deterioration (corrosion) or chemical deterioration (carbonation, salt attack, alkali-aggregate reaction, etc.). Examples of this seen to date in steel and composite structures that have suffered damage or been repaired include fatigue of steel members or floor slabs (related to fatigue resistance), deterioration of steel (related to corrosion resistance) and deterioration of concrete-based materials. In order to ensure that the durability performance of steel and composite structures is maintained throughout their design working life, controlling these types of damage is important.

Additionally, to ensure that the durability of structures is maintained, it is important to carry out suitable maintenance in which design and construction are considered. Concretely, it is important to draw up a maintenance plan during the design phase and to carry out maintenance based on this plan once the structure enters service. But it is also important to improve the maintenance methods used while taking into consideration the state of the structure at each maintenance step.

A conceptual schema showing a structure's durability performance and maintenance is shown in Fig.C8.1.1. This figure shows that after entering service, the performance of a structure deteriorates with time. It also shows that meeting the performance requirements of a structure throughout its design working life means carrying out repairs if, during the maintenance phase, the performance requirements are not satisfied. In this manner, this standard shows that the durability performance requirements of a structure can be maintained by considering how maintenance, which is most likely dealt with separately from design, is carried out from the design phase until renewal of the structure. Consequently, an important aspect of maintaining durability performance is to make maintenance easier by putting in place in advance equipment necessary for maintenance, such as inspection scaffolds or metal hanger fittings for painting.

If any performance requirement of a structure is found to be not satisfied at any time, reinforcement and/or repair is carried out according to the maintenance plan. Sometimes, certain parts of structural members may be replaced because their functionality deteriorates. However, in the conventional design

process, reinforcement and repair have not been considered during the initial design phase. As a result, not only is the workability of repair and reinforcement operations poor, but also the cost and time required are more than necessary. For this reason, this chapter prescribes the new requirement that maintainability must be considered when designing a structure. Moreover, the Maintenance and Management volume should be consulted for all aspects of this work after the structure enters service.

In some cases, (JSSC, 2001) durability is basically considered a verification of safety and is included in the safety requirements. In such cases, verification entails predicting the degree of damage and the associated change in strength with time after the structure enters service. As noted above, by dealing with performance requirements against durability, using such measures as fatigue resistance, corrosion resistance, resistance against material deterioration and maintainability, durability should be maintained. To make this very clear, and given that performance requirements other than safety must also be satisfied at all times after a structure enters service, durability is considered a performance item in this standard.

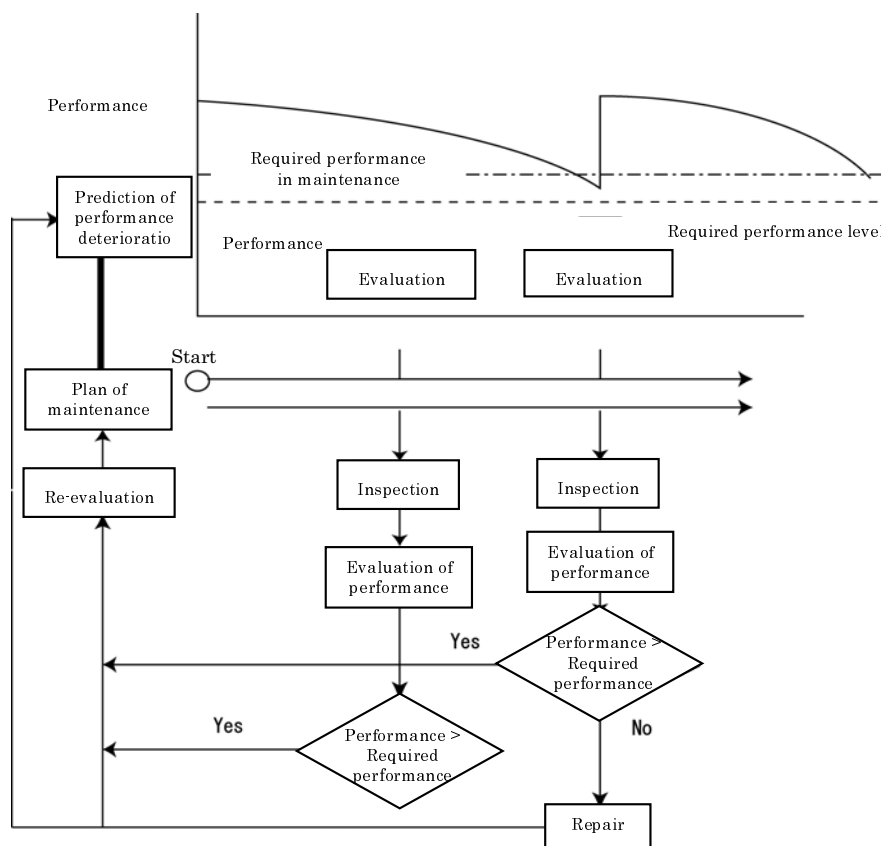

Fig.C8.1.1 Conceptual scheme of durability and maintenance of steel and composite structures

8.2 Required Durability Performance

8.2.1 Fatigue resistance

Steel and composite structures must never suffer fatigue failure due to repeated loading during the design working life. Namely, the design must take into account fatigue resistance such that no steel member cracks or fails even if a crack is initiated and then propagates.

【Commentary】

Any action such as wind load or traffic load acting repeatedly on steel and composite structures can cause fatigue crack initiation and propagation leading to fatal damage. For this reason, at the design stage it must be ensured that fatigue damage does not occur. To maintain steel and composite structures in healthy condition it is necessary to take appropriate measures against fatigue. The usual methods of preventing fatigue-cracking are to increase the thickness of members, therefore enhancing their stiffness, or to decrease stress. Another possibility is to improve structural details or welded joints so as to reduce local stress concentrations. For instance, smoothing the profile of a weld toe to reduce stress concentration is one method that has been used.

The fatigue resistance of a steel or composite structure is actually the resistance to fatigue of the structural members that compose it. Considering the setting of performance requirements over the design working life, levels may be set as shown in Table C8.2.1. Fatigue damage is well known to result from repeatedly applied action such as traffic load or wind load. However, depending on the structure under consideration, other types of repeatedly applied action might be present, so careful attention must be paid.

Table C8.2.1 Examples of levels of fatigue resistance performance requirements

	Level 1	Level 2	Level 3
Durability performance requirement	Fatigue cracking may not initiate throughout design working life to maintain service at its starting level	Fatigue cracking may not initiate in main members, though it is allowed in secondary ones, throughout the design working life to maintain service at its starting level	Fatigue cracking may initiate but after inspection or management, repairs or reinforcement are carried out if required
Investigation index	Stress range	Stress range or frequency of repair or reinforcement	
Maintenance level	• periodic inspection	• periodic inspection • repairing fatigue crack if required	• periodic inspection • repair or reinforcement if required

8.2.2 Corrosion resistance

Steel and composite structures must maintain the required level of mechanical performance and function even if steel corrosion takes place under the expected environmental actions throughout the design working life. No failure of a steel member is allowed.

【Commentary】

The occurrence of corrosion and the factors that cause it to accelerate differ greatly according to the details of the structure and its location. For example, in a coastal region influenced by airborne salt or coat or in a location with bad drainage where water may persist for hours, corrosion accelerates remarkably (JRA, 2002a). In particular, in the case of steel bridges comprising many members, the duration of wetting caused by rain or dew condensation, the presence of sand-mud sediments, which are seen as one factor causing corrosion, and the quantity of anti-freeze agent adhering to the structure differ with each installation. The corrosion resistance of steel is defined as the resistance of the steel used for the structure against corrosion. From the point view of maintaining performance during the design working life, a level of corrosion resistance can be set as a performance requirement, for instance as seen in Table 8.2.2 (RTRI, 2000).

In the case of a painted steel structure for which a corrosion resistance of performance level I is

Table C8.2.2 Examples of corrosion resistance performance level

	Level 1	Level 2	Level 3
Durability performance	A small decrease in cross section is allowed over the design working life but the loading capacity must be maintained unchanged	Cross sections may decrease as a result of corrosion during the design working life and loading capacity may also fall, but no replacement of structural members or reinforcement work is required.	Decrease of cross section caused by corrosion during design working period and of associated load capacity is allowed. Replacing members during design working period may be done.
Investigation index	Amount of decrease in plate thickness, loading capacity		
Maintenance level	<ul style="list-style-type: none"> • periodic inspection • periodic repainting, etc. 	<ul style="list-style-type: none"> • periodic inspection • if required: repairs, painting, etc. 	<ul style="list-style-type: none"> • periodic inspection • detailed survey if corrosion is found to have progressed • repairs or reinforcement if required
Remarks			Applied to temporary structures

set as the target, the required performance may be achieved using methods such as regular repainting. For example, bridges that carry Shinkansen (bullet train) traffic are regularly repainted (every 5 to 7 years) after entering service so as to avoid corrosion. For an ordinary steel structure, repainting is often carried out according to the degree of deterioration; in such cases, the set target is that corrosion resistance of performance level II should be achieved.

Further, in the case of a non-painted steel structure that is serviced, in a corrosive environment, using weathering steel that is usually in a healthy condition, the target is to maintain a corrosion resistance of performance level I. However, it cannot be expected that fine rust will be formed on bridges constructed on the water's edge or in coastal areas in the particular locations (specific members or structural positions) where an anti-freeze agent (sodium chloride or calcium chloride) is applied. In these cases the target should be to maintain a corrosion resistance of performance level II. Moreover, experience has shown that in the case of non-painted steel structures corrosion does not advance beyond the point where stable rust is generated. However, recent practice is to assume that corrosion may occur but corrosion resistance performance is maintained since the progression of corrosion is held within a fixed limit.

The steel reinforcement inside concrete may corrode as a result of carbonation of the concrete, chloride ion infiltration, freeze-thaw action, chemical attack, the alkali-aggregate reaction and others. The performance of a structure must be assured against such corrosive attack. Reference JSCE, 2001 explains the process of concrete deterioration caused by each of these deterioration factors, the process of corrosion of steel inside the concrete, the grading of a deteriorated structure in terms of appearance, and standards for the deterioration of performance.

As this makes clear, one performance requirement pertaining to the corrosion resistance of steel and composite structures is that corrosion of the steel used should be inhibited throughout the design working life.

8.2.3 Resistance to material deterioration

Steel and composite structures must maintain the required performance level with respect to material deterioration throughout the design working life.

【 Commentary 】

Resistance to material deterioration represents performance with respect to durability against of any concrete used in steel and composite structures. For structural members using concrete, such as in floor slabs, this performance requirement must be considered and dealt separately from the steel material. This is explained in section 14.5.2 "Resistance to concrete deterioration" in Chapter 14 "Slab Design". The material deterioration of concrete is not considered affected by corrosion of steel because of freezing damage, chemical erosion, the alkali-aggregate reaction, and so on. Verification indices of performance relating to these deterioration factors are explained in reference JSCE, 2002b. Time-dependent changes or performance deterioration of concrete-based structures caused by these deterioration factors are explained in reference JSCE 2001.

8.2.4 Maintainability

Ease of repair must be considered against time-dependent degradation of members due to fatigue, corrosion, and material deterioration throughout the design working life.

Ease of maintenance, covering repair and inspection, after entry into service must be considered.

【 Commentary 】

- (1) In addition to fatigue, corrosion and material deterioration as described above, functional deterioration may also be related to repair requirements. For example, there are factors aside from fatigue, corrosion, and material deterioration that make it necessary to replace expansion joints, bearing supports, distribution pipes, and other components. Maintainability relates to the investigation of function deterioration caused by these factors.

For instance, it is must be checked that a suitable number of metal hangers are installed in appropriate places to allow for the setting up of scaffold for repainting. The structure must also be designed to make scraping work easy. Repainting is one of the standard maintenance tasks for steel and composite structures. And in considering structural details, it must also be ensured that members such as expansion joints, bearing supports, or floor slabs can be replaced easily.

- (2) At design phase, consideration must be given to the ease of carrying out maintenance operations such inspections, repairs, maintenance management, and so on. Moreover, the basic position should be that the investigation, cleaning, and painting of a structure can be carried out easily.

8.3 Verification of Durability

8.3.1 Verification of fatigue resistance

8.3.1.1 Verification of fatigue under repeated loading

The verification of fatigue under repeated loading must in principle involve using the following method. If another adequate verification method is available, it may be applied. Verification of fatigue under wind loading shall be in accordance with 8.3.1.2.

- (1) It must be confirmed that no welded joints of low fatigue strength or for which quality control is difficult are used in fabricating steel members.
- (2) For steel members, it must be confirmed whether the maximum stress range resulting from

repetition of expected actions throughout the design working life is less than the fatigue limit (cut-off limit).

- (3) In a case where the maximum stress range is greater than the fatigue limit (cut-off limit) under the expected actions throughout the design working life, it must be confirmed that the cumulative fatigue damage is less than the threshold value for fatigue failure.
- (4) In verifying the fatigue of concrete members, it must be confirmed that serviceability and mechanical performance are maintained under the expected actions throughout the design working life.

【Commentary】

In the fatigue investigation of steel members in a steel and composite structure, the members must be confirmed to have the required durability by evaluating the effect of stress fluctuation caused in members by actions such as the live load.

- (1) When selecting a structure, one with joints exhibiting particularly low fatigue strength or one previously reported as suffering damage due to fatigue should not be chosen. Locations where fatigue cracking has been reported as occurring to date are the welded joints of sole plates in bearing supports, welded joints at cut-out flange-web intersections with the main girder, gusset plate welded joints with lateral bracing, welded joints between upper and lower ends of a vertical member in an arch bridge, connections between floor beam members, connections between web sections of transverse ribs and longitudinal ribs in an orthotropic steel deck, and welded beam-to-column joints in a steel pier. In designing such welded joints, sufficient attention must be paid to avoid fatigue problems. Typical fatigue damage may be seen in reference JRA, 1997.

For joint members, joint designs with low fatigue strength or whose quality can be maintained only with difficulty, such as welded joints with backing strips, fillet welds in cross-shaped load-carrying joints, partial penetration welds, lap joints, gusset welded joints penetrating the web of a main girder, and interruption joints in steel pipes, should be avoided. If it is necessary to use these types of joint, it must be confirmed that fatigue cracks will not occur throughout design working life.

- (2) Basically, the joints or structures used should be ones in which the required fatigue resistance is assured throughout the design working life by evaluating the effect of stress fluctuations caused in members by actions such as the live load. For instance, in the case of highway bridges, the calculated stress range obtained with the fatigue design load is applied movably against lanes must be confirmed to be below the fatigue limit (cut-off limit) determined beforehand for each joint.

In choosing joint types, welded joint positions, and structural details, it is important to consider such points as the degree of stress concentration and the secondary stress caused in actual use, which are regarded as difficult to take into account at the design phase. Additionally, for complex structures where conventional stress investigations are considered difficult, the stress range may be investigated using analysis methods such as FE.

- (3) If the calculated stress range in (2) above is not below the fatigue limit (cut-off limit), an investigation based on the linear cumulative damage rule, in which the effect of repeated load over a period (of almost 100 years) is accounted for in design, must be considered. Same in railway bridge, after calculating the maximum stress range using the characteristic loading values determined from the loading frequency and the magnitude of the train load, it must be confirmed that this value is less than the fatigue limit (cut-off limit) of each joint. In the case of not, as done similarly in highway bridge, a linear cumulative damage rule based investigation considering the effect of repeating load throughout the design working period (60 or 70 years) must be considered.

These investigations may be seen in the references Fatigue Design Recommendations for Steel

Structures (JSSC, 1993a), Fatigue Design Recommendations for Steel Highway Bridges (JRA, 2002a), and Fatigue Design Recommendations for Steel Railway Bridges (RTRI, 2000).

- (4) The same for steel and composite structures, investigations done in (4) must be done. The investigation of other composite structures between steel and concrete is available in the reference JSCE, 2002a. Structures such as pre-stressed floor slabs or composite floor slabs between steel and concrete are investigated in section "14.4.1 Fatigue resistance of slab" of Chapter 14.

8.3.1.2 Verification of fatigue under wind loading

Verification of fatigue under wind loading must in principle involve confirming that the wind velocity at which vortex-induced vibrations arise is greater than the design wind velocity or the amplitude of vortex-induced vibrations is less than a threshold value. If another adequate verification method is available, it may be applied.

【 Commentary 】

In considering the fatigue of steel structures caused by wind loading, the most important phenomenon in the dynamic wind response is vortex-induced vibration. This type of vibration is a phenomenon that occurs over a limited range of both wind velocity and wind amplitude, but because fatigue occurs at a comparatively low wind velocity, its investigation is very important. Vortex-induced vibration has been reported as occurring in bridge girders, the main towers or cables of bridges of suspended structure or with hanging members, such as Langer bridges, and even in attachments such as lighting columns and handrails, etc.

With the present level of technology, the most reliable way of predicting the dynamic wind response phenomena of structures is to use wind tunnel tests. On the other hand, wind tunnel tests are not always a convenient means of investigation because a wind tunnel is a specialist item of equipment, so they cost money and time. To simplify investigations aimed at proofing structures against dynamic wind response, the Wind Resistant Design of Bridge Road Handbook (JRA 1991) provides some estimated formulas that give results on the safe side for structures, mainly bridges, with spans up to 200 m. These formulas, which are based on past tests, can be used to determine whether it is necessary to investigate the wind velocity at which phenomena occur in more detail and are also used in Standard Specifications for Concrete Structures.

If it proves possible to predict the wind velocity that causes vortex-induced vibration of a certain using these methods, the fatigue investigation can be carried out by confirming that wind velocity that induces vortex-induced vibration is greater than the assumed velocity and that the amplitude of vibrations that occur is smaller than the allowed amplitude. Moreover, the investigation of wind velocity and allowed vibration amplitude may be carried out with reference to Wind Resistant Design of Bridge Road Handbook (JRA, 1991).

In general, the wind velocity at which vibration occurs in attachments such as hanging members or even lighting columns and handrails may be estimated, but it is difficult to predict the amplitude of vibration with high accuracy. Therefore, after confirming whether vibration occurs at the predicted wind velocity or not through careful observations while construction is under way, measures to effectively control the vibration may be taken if necessary.

Looking at the occurrence of fatigue in steel structures resulting from wind action aside from vortex-induced vibration, consideration may have to be given to gust response and rain vibration, which is a unique vibration phenomenon of cables. Gust response is an irregular vibration phenomenon caused by airflow disorder and is characterized by an amplitude that increases gradually as wind velocity increases. However, gust response is not usually considered a problem except in particularly unusual cases such as suspension bridges of unusual scale and which transform easily or cable-stayed bridges.

However, the additional effect of gust response is considered in the regulations on wind loading in the Standard Specifications for Concrete Structures (JRA, 2002a). Rain vibration is a vibration phenomenon caused in the cables of cable-stayed bridges during rain or when the wind is strong. Recently, even in the absence of rain, attention must be paid to cable vibration because some research results have indicated a dynamic response to wind acting at an angle. However, there have been no cases of fatigue failure caused by rain vibration up to now in the cables used in Japan.

8.3.2 Verification of resistance to steel corrosion

Verification for resistance to steel corrosion must in principle involve using the following method. If another adequate verification method is available, it may be applied.

- (1) In a case where the corrosion protection method consists of a surface coating such as paint, it must be confirmed that the specific coating selected is suitable for the particular corrosive environment.
- (2) In a case the corrosion protection method is anything except natural weathering of the steel or a surface coating, it must be confirmed that the specific corrosion protection method selected is suitable for the particular corrosive environment.

Regarding corrosion of steel reinforcement in concrete, it must be confirmed that the concrete carbonation depth and the chloride ion concentration remain below the threshold values for the occurrence of steel corrosion.

【 Commentary 】

Methods of corrosion prevention for steel must achieve the required durability against the environmental conditions in which the steel is employed. However, the scale, shape, and other characteristics of the materials that may be applied with a particular method are limited. These limits and the conditions of each method with respect to workability of repairs and the difficulty of carrying out the inspections required to maintain corrosion prevention performance also differ from method to method. Therefore, in selecting a method of corrosion prevention, it is necessary to consider cost-effectiveness, a maintenance plan for inspection and repair, and environmental conditions along with requirements related to durability, aesthetics, etc. To prevent steel corrosion, available methods include surface coating, surface treatment, galvanic corrosion protection, and treatment of the steel itself.

In general, surface coating is able to prevent corrosion or control it below a fixed limit. Because the performance of coating methods normally deteriorates gradually over time, the ability to maintain performance above the fixed standard depends on drawing up and implementing a suitable and effective maintenance plan (including inspection, examination, repair, etc.). To achieve this, it is essential to implement suitable accelerated tests or exposure tests under the environmental conditions of the construction site to clarify structure durability and confirm the principle of the chosen corrosion prevention method. Effective inspection, examination, and maintenance is not possible without a clear plan, so adequate attention must be paid to this when adopting a corrosion prevention method for steel structures.

Practical results to date indicate that certain representative corrosion prevention methods, such as surface coating or using weathering steel, zinc plating, or metal thermal sprays, are able to satisfy the performance requirements in general if design and maintenance are properly implemented. The principles of these corrosion prevention methods, the manner in which their functionality fails, and repair methods that can be used to recover functionality are explained in Table C8.3.1 (JRA, 2002a).

- (1) The most used method of preventing steel corrosion is to add a protective film by surface coating. Although this method imposes few structural restrictions and offers a large degree of freedom in selecting the finish color, factors in the environment do cause the paint film to deteriorate so

Table C8.3.1 Representative corrosion prevention methods

	Basic principle	Mode of loss of functionality(including unpredicted deterioration)	Recovery method when function lost
(1) surface coating	Isolating from corrosion environment with a paint layer	Deterioration of paint layer	Repainting
(2) steel weathering	Controlling corrosion by generating a fine rust layer	Peeling of rust layer. Associated decrease in cross section	Painting, etc.
(3) stainless steel	Controlling corrosion by means of a oxide layer passivation film	Localized corrosion as pits generated when the film is thin	Painting, etc.
(4) hot dip galvanizing	Protective film of zinc oxide and sacrificial corrosion prevention by zinc	Decrease of zinc layer thickness	Thermal spraying or painting
(5) metal thermal spray	Sacrificial corrosion prevention by spraying with a metal (zinc, aluminum, pseudo-alloy, etc.) to form a protective film	Thinning of sprayed metal layer (zinc, aluminum, zinc-aluminum pseudo-alloy, etc.)	Thermal spraying or painting

recoating must be carried out periodically in order to maintain functionality. The deterioration rate of the paint film is determined from the relationship between corrosion factors such as airborne salt in the environment to which the structure is exposed and the characteristics of the paint film itself. As a consequence, the investigation of corrosion resistance entails choosing a paint specification (JRA, 1990 and JBA, 1996) and confirming that a suitable repainting cycle is set in consideration of the corrosion environment, which depends on the structure's configuration and location. As an example, one method of deciding when to repaint depends on the rusted area exceeding 0.3

- (2) The addition of an appropriate quantity of an alloying element (Cu, Cr, Ni, etc.) to steel, to create weathering steel, will cause fine rust to be formed. This fine rust layer inhibits the development of rust and protects the steel surface, reducing the overall corrosion rate as compared with plain steel. In other words, corrosion is gradual and performance deterioration is suppressed. Nevertheless, there can be problems with the uniformity of the fine rust layer leading to uneven corrosion rates, particularly where there is airborne salt, where an anti-freeze agent is used (or used nearby), where a bridge is readily influenced by chloride, or where full wetting and drying cycles are lacking. Consequently, this method should be used only under suitable conditions according to the type of material (JRA, 2002a).

To give an example, hot-rolled atmospheric corrosion resisting steels for welded structures (SMA) are specified in JIS G 3114. These are, in principle, for use without painting in regions where the amount of airborne salt, as measured by a prescribed method, is below 0.5 mdd (NaCl: mg/100cm²/day); these areas are shown in Fig.C8.3.1 (PWRI, The Kozai Club, and JBA, 1993). Others like attention at designing or constructing when weathering steel is used in such truss bridge, arch bridge or rigid frame bridge are given concretely in this reference and should be consulted. Recently, types of weathering steel (Ni-based high corrosion resistance weathering steel) have been developed with improved chloride resistance, improved surface processing to accelerate the generation of fine rust, and better prevention of flowing rust. These types of weathering steel have come into use in steel structures, but if they are to be used proper investigations of corrosion resistance must be carried out considering the actual environment and standard of corrosion

prevention.

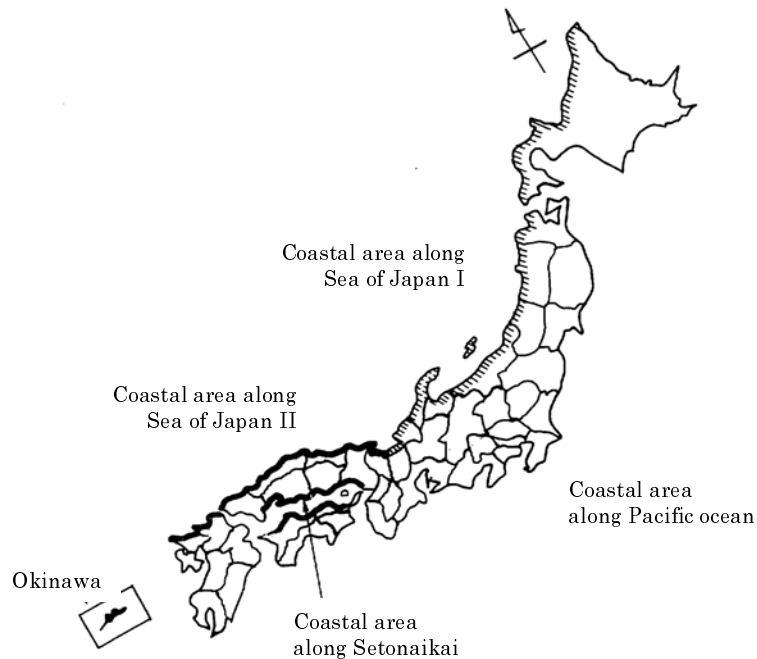

Classification of area		Airborne salt measurements not required
Coastal areas along Sea of Japan	I	More than 20 km from the coastline
	II	More than 5 km from the coastline
Coastal areas along Pacific ocean		More than 2 km from the coastline
Coastal areas along the Inland Sea (Setonaikai)		More than 1 km from the coastline
Okinawa		Always required

Fig.C8.3.1 Classification of areas in which unpainted weathering steel is applicable

In hot dip galvanizing, steel is dipped into molten zinc at around 440 °C, forming a two-layer surface film consisting of a steel-zinc alloy and pure zinc. Corrosion of the steel is suppressed by the protective effect of this film and by sacrificial oxidation of the surface of the film. The long-term durability of zinc plating for a particular structure cannot be well understood until a tracing survey is carried out, but in some places affected by seawater or sea breezes, the protective film may not form and the zinc layer and alloy layer are gradually consumed. Consequently, a structure will require painting in the future. Moreover, structural considerations such as restrictions on the size of members imposed by the size of the zinc plating tank and the possibility of thermal transformations in the plating tank are required at design phase (JRA, 2002a). In addition, plating burn and plating cracks must be avoided during the zinc plating process. Details should be looked up in literature (JSSC, 1996).

Metal thermal spraying is a method in which a shielding layer is created by spraying molten metal using compressed air onto the steel surface after carrying out some surface processing, such as grinding. Zinc, aluminum, or an alloy of zinc and aluminum can be used for metal thermal spraying. As a method of forming a metal layer on the steel surface, it differs from hot dip galvanizing in that application is not restricted by the scale and size of the structure. Metal thermal spraying provides a surface with a great many concavities and convexities, so paint adherence is good and it can be used as a foundation for painting (JRA, 2002a).

To ensure that a corrosion prevention method operates optimally, every detail of the structure

must be considered thoroughly in consideration of the method being used, with detailing such as chamfering used where needed. Further, when different types of metal come into contact with each other, as in welding or bolting of parts, the material of lower electric potential experiences accelerated corrosion corresponding to the difference in electric potential. In such cases, measures such as isolation should be implemented (JRA, 2002a).

- (3) The steel used in reinforced concrete is protected by a passivation film that forms in the highly alkaline environment. However, even in this environment, the steel may begin to corrode and corrosion will progress if the concentration of chloride ions exceeds a certain value and causes the film to be unstable. Once corrosion of the steel starts, cracks form comparatively early and the corrosion process accelerates. On the other hand, concrete undergoes carbonation through reaction with the carbon dioxide in the air. This relates to the water-tightness (ventilation ability) of the concrete and elapsed time.

As a general rule, it is necessary to confirm that throughout the design working life the depth of carbonation does not reach the limit at which corrosion of the steel starts and that the chloride ion concentration at the steel surface remains below the concentration at which corrosion starts (JSCE, 2002b). Surface coating, steel shielding, and other measures (of coating or plating) may be used to protect the concrete (JCI, 1998). Details of protection methods against corrosion, such as electrical methods that restrict corrosion progression of the steel, suitable shielding materials for the steel, and coating materials for the concrete surface, are given in JCI, 1998.

The most common method of predicting the approximate depth of carbonation, based on historical records, is to treat it as proportional to the square root of service period. At present, the need for measures against carbonation is investigated by checking that the design value of carbonation depth, found from the carbonation rate coefficient (calculated using the type of cement and water-cement ratio) is less than the limit depth (calculated by subtracting the remnant neutral depth from expected value of cover depth) at which the steel starts to corrode. However, JSCE, 2002b should be consulted about certain cases in which, if the cement being used and water-cement ratio and the cover depth satisfy some conditions, it is not generally possible to omit investigations of carbonation.

- (4) Specific details relating to the corrosion protection of steel in concrete can be obtained from the literature (JSCE, 2002a; JSCE, 2002b; JRA, 2002b). But in some environments, especially where anti-freeze agents are used, taking certain suitable measures such as to prevent the ingress of water with chloride ions into the concrete is recommended (JSCE, 2002b). Additionally, standard methods for maintenance should be consulted in the literature (JSCE, 2001). Details of repair and reinforcement methods can also be obtained from the literature (JSCE, 1999 or JCI, 1998).

8.3.3 Verification of resistance to material deterioration

Verification of resistance to material deterioration must in principle involve using the following methods. If another adequate verification method is available, it may be applied.

- (1) It must be confirmed that concrete has the required frost resistance by determining the dynamic elastic modulus and mass loss in freezing and thawing tests.
- (2) Regarding concrete corrosion due to chemical attack, it must be confirmed through accelerated tests, atmospheric exposure tests, or another adequate verification method that concrete deterioration does reach a tangible level or affect the required level of performance.
- (3) It must be confirmed that concrete has the required resistance to the alkali aggregate reaction (ASR).
- (4) In a case where a surface coating is applied to concrete, the waterproofing effect of the coating must be confirmed in consideration of maintenance planning.

【 Commentary 】

- (1) The main causes of deterioration of concrete itself are freezing, chemical erosion, and the alkali-aggregate reaction. Freezing-induced deterioration may be seen not only in cold climates but also in mountainous areas. Concrete's resistance to freezing is influenced by large number of factors in addition to its overall quality, including how low the temperature falls, the number of freeze-thaw cycles, the degree of water saturation, etc. Evaluating these factors accurately is not an easy task. At present, it is specified that investigating the freeze-thaw performance of a structure should be carried out by performing accelerated freeze-thaw tests and using as indices the loss of mass and the relative dynamic Young's modulus of the concrete (JSCE, 2002b). Additionally, if the water-cement ratio and air content can be confirmed to satisfy some certain conditions, the above type of investigation can be replaced by certain confirmations and such the upper limit of water cement rate should be considered at mix design phase may be consulted from the reference (JSCE 2002b), and appendix 1.
- (2) Chemical erosion of concrete is multifarious and depends on the power of external deterioration actions in the environment. As a result, determining the durability performance of concrete against these external actions is difficult and impractical. Because in oceanic environments or environments influenced by, for example, acid rain erosion actions are relatively moderate as so the standard required about chemical erosion resistance in concrete should require deterioration of concrete not become remarkably. In some environments, such as in sewage systems or in hot-spring facilities, where severe erosion actions are acting, the performance requirement should be that deterioration of the concrete does not affect the required performance of the structure. These two facts are recommended as the standard for chemical erosion resistance of concrete (JSCE, 2002b). The confirmation items mentioned above and some specific investigations may be found in JSCE, 2002b.
- (3) No practical prediction formula has yet been established for the alkali-aggregate reaction, so the alternative of confirming resistance to the reaction through an accelerated test on a concrete test piece is adopted here. An example of a test method is given in JSCE, 2002b. Additionally, using the measures given in a notification by MLIT (Controlling measure against alkali-aggregate reaction) or in Annex 1 and 2 (Regulations) of JIS A 5308, it should be determined whether the alkali-aggregate reaction can be controlled.
- (4) The literature (JSCE, 2002a; JSCE, 2002b; JRA, 2002b) should be consulted about considerations related to coating the surface of concrete or for details of preventing deterioration of the concrete itself. Also, JSCE, 2001 should be consulted for standard methods of maintenance. Details of repair and reinforcement methods may be found in JSCE, 1999 or JCI, 1998.

8.3.4 Verification of maintainability

Verification of maintainability must in principle involve determination at the design stage of ease of maintenance, including inspection and repair, throughout the design working life. If another adequate verification method is available, it may be applied.

【 Commentary 】

In evaluating the performance of steel and composite structures with respect to the maintenance plan, the repairs that might become necessary as a result of deterioration may be repainting, expansion joint repair, bearing support repair, distribution pipe repair, floor slab replacement, and other steel member repairs. It should be confirmed that structural details are such that these kinds of repair tasks are feasible.

For instance, repainting work requires that a scaffold can be easily installed and that structural

details make painting and scraping work easier. Also, when jacking up the main girder to replace a bearing support, it will be difficult to insert the jack unless there is adequate working space between bridge and abutment members. That means it is necessary to consider whether adequate work space is provided during the design phase, and also to ensure that a sole plate is fitted to the flange to take the jack and that any additional vertical stiffeners are provided. The structure of abutments and piers that carry the reaction force must be considered also. To give an example, in many cases a bracket is used to support the jack, to do same in a metal bridge pier, a structural detail in which a bracket is able to be installed must be considered. In designing a concrete bridge pier, it must be confirmed during the superstructure design phase that the reinforcing are arranged such that anchor bolts can be appropriately installed.

The items which such repair and reinforcement works must be confirmed against fatigue may be such space enough to carry members and equipment or structural detail in which carrying equipment in is made more easily. Moreover, the presence of suitable manholes for carrying equipment into a steel girder, cable rack, or distribution pipework and their workability must be confirmed. It should also be confirmed that suitable ventilation is possible. These structural details and precedents can be found in JRA, 2002a or JBA, 2002.

References in Chapter 8

- Japan Road Association (1990) : Wind-resistant Design Manual for Highway Bridges .
- Japan Road Association (1991) : Wind-resistant Design Manual for Highway Bridges.
- Public Works Research Institute, the Kozai Club, and Japan Bridge Association (1993) : Research Committee on Application of weathering Steel to Bridge, Report of Cooperative Research on Application of weathering Steel to Bridge, XX.
- Japanese Society of Steel Construction (1993a) : Fatigue Design Guideline for Steel Structures and Commentaries.
- Japanese Society of Steel Construction (1993b) : Investigation Manual of Painted Steel Bridges, JSS IV03-1993 .
- Japan Bridge Association (1996) : Paint Guidebook for Bridge Engineers.
- Japanese Society of Steel Construction (1996) : Design and Guide for construction of Hot Dip Galvanizing Bridge.
- Japan Road Association (1997) : Fatigue of Steel Structures.
- Japan Concrete Institute (1998) : Report of Research Committee on Rehabilitation of Concrete Structures.
- Japan Society of Civil Engineers (1999) : Reinforcement Guideline of Concrete Structures (Draft), (Concrete Library, No.95).
- Railway Technical Research Institute (2000) : Fatigue Design Recommendations for Steel Railway Bridges, Steel and Composite Structures.
- Japan Society of Civil Engineers (2001) : Standard Specifications for Concrete Structures, Maintenance Volume.
- Japanese Society of Steel Construction (2001) : Investigation Research Subcommittee on based design for Steel Structures, Guideline of Performance based design for Steel Structures, JSSC Technical Report, No.49.
- Japan Society of Civil Engineers (2002a) : Standard Specification for Concrete Structures, Structural Performance Verification Volume.
- Japan Society of Civil Engineers (2002b) : Standard Specification for Concrete Structures, Construction Volume.
- S.Nakatani, K.Uchida, K.Nishikawa, M.Kanda, K.Miyazaki, S.Kawama and S.Matsuo (2002) : Experimental study on the fatigue durability of highway bridge slab, National Institute for Land and Infrastructure Management, No.28.
- Japan Bridge Association (2002) : Repair and Reinforcement Examples of Steel Bridges.
- Japan Road Association (2002a) : Specifications for Highway Bridges and Commentary, I Common Specifications Volume, II Steel Highway Bridges Volume .
- Japan Road Association (2002b) : Specifications for Highway Bridges and Commentary, I Common Specifica-

tions Volume, II Concrete Bridges Volume .

Japan Road Association (2002c) : Fatigue Design Guideline for Steel Highway Bridges .

Japanese Society of Steel Construction (2002d) : Reference on Proof Stress, Durability and Reinforcement for Constructed Steel Bridge Members.

Japan Road Association (2005) : Handbook of paint and corrosion prevention for steel highway bridges.

Chapter 9 Required Social and Environmental Compatibility Performance and Verification

9.1 General

- (1) Steel and composite structures shall maintain their social and environmental compatibility under the actions specified in Chapter 2 throughout the construction and in-service periods.
- (2) Performance items related to social and environmental compatibility include social compatibility, economic rationality, and environmental compatibility.
- (3) Social and environmental compatibility shall be verified with respect to the limit state established for each performance item by setting a proper performance index representative of each performance item. However, in cases where there are difficulties in setting and verifying such limit states for social and environmental compatibility, society and environmental compatibility shall be verified by optimizing each performance item.

【 Commentary 】

Steel and composite structures should be compatible with social and environmental conditions, meaning that adverse influences on the surrounding social and natural environments should be minimized.

In this specification, performance requirements include verifying social compatibility in consideration of the social importance of the structure, economic rationality (to check economic efficiency over the structure's life cycle), and environmental compatibility (to check environmental loading from CO₂ emissions and harmonization with the structure's surroundings).

In cases where it is difficult to set limit states for social and environmental compatibility, verification should be by optimizing the performance requirements.

9.2 Required Social and Environmental Compatibility Performance

- (1) Steel and composite structures shall be designed to provide the functions required according to their importance.
- (2) Steel and composite structures shall be designed to be safe and functional and to minimize both construction cost and life-cycle cost.
- (3) Steel and composite structures shall be designed to avoid adverse effects on the surrounding social and natural environments resulting from vibration and noise, to minimize environmental impacts, such as CO₂ emissions, throughout their life cycle, and to offer an aesthetic that does not provoke undesirable psychological reactions in people nearby.

【 Commentary 】

Performance requirements to ensure the social and environmental compatibility of steel and composite structures include social compatibility, economic rationality, and environmental compatibility. Because steel and composite structures can strongly affect social and economic activity, they should be designed such that the functionality required according to their importance level is attained. It is generally unacceptable for steel and composite structures to have excessive safety and compatibility

with society and the environment. Rather, they should be designed to provide adequate safety and functionality while minimizing not only construction cost but also life cycle cost.

In generally, steel and composite structures are expected to have a service life of 50 years and over this time they can strongly affect the surrounding social and natural environments. They should be designed so as to not adversely affect the surrounding social and natural environments with vibration and noise, to minimize environmental impacts, such as lifetime CO₂ emissions, and to avoid undesirable psychological reactions among those who see them.

9.3 Verification of Social and Environmental Compatibility

9.3.1 Verification of social compatibility

Social compatibility shall be verified by confirming that the performance index representative of each performance item satisfies the limit-state requirements established for that performance item in consideration of the importance of the steel or composite structure.

【Commentary】

Structural factors can be determined as specified Chapter 1 section 1.5 in consideration of social and economic impacts, importance in disasters, and economic factors such as reconstruction and repair costs at the time when the structure or its members reach their limit states as a result of actions during the construction and in-service periods. The social compatibility of structures should be verified using the appropriate structural factors for safety, serviceability, and durability as defined in Chapters 6, 7, and 8, while economic rationality and environmental compatibility are specified in this chapter.

The owners (contracting parties) of structures may determine the values of structural factors because they cannot be logically defined based on reliability theory. However, the values of structural factors shown in Table C1.5.1 can generally be adopted.

9.3.2 Verification of economic rationality

Economic rationality shall be verified by confirming that the life-cycle cost (LCC) of a steel or composite structure is minimized or that the life-cycle utility (LCU), including social, economic, and cultural utilities, is maximized. However, in a case where it is impossible to satisfy these conditions, economical rationality shall be verified by optimizing LCC or LCU.

【Commentary】

Since many steel and composite structures form part of the social capital, they are required to offer effective functionality within limited budgets. For this reason, it is difficult to obtain social consensus for excessively high levels of safety, serviceability, repairability, durability, constructability, and the social and environmental compatibility specified in this chapter. However, it is extremely difficult to properly set performance levels for structures. One effective method of dealing with this problem is to determine each performance level so that the life-cycle cost (LCC) of a structure is minimized. LCC includes the following costs.

- (1) Investigation and project costs
- (2) Initial construction costs (including land acquisition, etc.)
- (3) Maintenance and repair costs during in-service period
- (4) Removal costs
- (5) Depreciation based on social discount rate
- (6) Anticipated value of loss (damage and loss of the structure, loss of human life, social, economic,

and cultural losses caused by functional failure of the structure, etc.) if the structure reaches a limit state

Costs (1) to (5) can be calculated with relative ease, but further research is needed in order to estimate cost (6). At present, costs (1) to (4) can generally be considered in performance verification by LCC.

Since social capital essentially plays a role in creating a more affluent national life, it may be insufficient to focus on only the actual cost of a structure. Therefore, both positive and negative effects (utilities) of a structure should be considered in performance verification. For example, the social, economic, and cultural utility of the existence of a structure and the service it provides as well as the recyclability of the structural materials can be quantitatively evaluated as contributing to positive utility, while construction and maintenance costs can be treated as negative utility. The life-cycle utility (LCU) of a structure can then be defined as the sum of the positive and negative utility values. This means that the ideal approach is to determine each performance level so that LCU is maximized. Although the concept of LCU has been little researched so far, performance verification in terms of LCU is also described in this chapter. It is expected that research in this field will progress in the near future, leading to greater understanding of the utility and benefit of steel and composite structures among the general public.

9.3.3 Verification of environmental compatibility

Environmental compatibility shall be verified by confirming that performance indices for vibration and noise, which might adversely affect the surrounding social and natural environments, environmental impacts such as CO₂ emissions, and landscape are less than the specified criteria. However, in a case where it is impossible to satisfy these conditions, environmental compatibility shall be verified by optimizing each performance item.

【 Commentary 】

Performance requirements related to environmental compatibility are vibration and noise (which can adversely affect the nearby social and natural environments), environmental impacts (such as CO₂ emissions over the life cycle of the structure), and the appearance of the structure to people nearby.

If there is a possibility that a structure will cause environmentally harmful vibration and noise during construction and the in-service period, performance levels estimated using numerical analysis and from previous similar examples should be confirmed to be less than the criteria specified in the environmental quality standards or by ISO. As for noise and vibration from large highways close to residential areas, the sound pressure level generated by vehicles is generally regulated under the noise regulation law and the vibration regulation law. The limit of vehicle noise is 45 to 80 dB, depending on the area classification and time of day under the noise regulation law, while traffic-induced vibration is limited to 60~70 dB depending on the area classification and time of day under the vibration regulation law [Japan Society of Civil Engineers, 2002]. In addition, some local governments specify their own environmental criteria and these limit values can generally be used for performance verification. Methods of estimating the noise and vibration generated by structures can be classified as analytical methods based on techniques reported in the literature and analogies based on measurements taken in similar structures [Japan Society of Civil Engineers, 2003]. On the other hand, limits on low-frequency sounds have been defined as "100% pass level L50 in the range 1~80 Hz is lower than approximately 60~90 dB for low-frequency sound in the general environment" [Air Quality Bureau, Environment Agency, 1984] and alternatively as "G-weighted sound pressure level in the range 1~20 Hz is around 100 dB for perceptible low-frequency sound" [ISO, 1995]. These values can be taken as the limit values for low-frequency sound. Further, the impact of vibration and noise on ecosystems, including

animals and plants, have not necessarily been evaluated quantitatively. Therefore, limit values should be appropriately determined with reference to research examples consisting of environmental impact assessments for existing similar structures.

As for environmental impacts, such as lifecycle CO₂ emissions, specific limit values and verification methods have not necessarily been proposed and future research results are awaited. At present, environmental impacts should be reduced as much as possible in consideration of economy and technology.

Universal and quantitative indices for the appearance of structures to people nearby have never been proposed and, as with the environmental impacts discussed above, future research is awaited. At present, attention should be paid to (1) making the structure mechanically clear, (2) choosing a suitable structure for the surrounding circumstance, (3) unifying structural types, (4) considering ancillary structures, and (5) other considerations (distance between bearings, position of bridge piers, etc.) as described in Part II Structure Plan of these specifications. In outline, a structure's appearance should avoid undesirable psychological reactions among people nearby while considering economy and technology.

References in Chapter 9

- Air Quality Bureau, Environment Agency(1984) : Reports on Low-Frequency Aerial Vibration
Japan Society of Civil Engineers (2002) : Guidelines for Performance Verification of Hybrid Structures (tentative) .
Japan Society of Civil Engineers (2003) : Towards establishment of performance-based design system for steel structures .
ISO(1995) : ISO7196 Acoustics-frequency Weighting Characteristics for Infrasound Measurements.

Chapter 10 Structural Members in General

10.1 Structural Members

All members are designed in a simple structure as possible for the convenience of fabrication, transportation, site construction, examination, painting, maintenance, patching etc. The examination of critical stage of members is given in chapter 6.

【Commentary】

The choice of a complex design for a structure can lead to various problems in terms of fabrication, transportation, erection, inspection, painting, draining, maintenance, and so on. Each structural member should be made as simple as possible, otherwise the design calculation will end up being too complex and substantial and unexpected secondary stresses may arise. In other words, if a structure is very difficult to fabricate then one cannot expect good-quality fabrication, while if it is difficult to transport it may end up being damaged during transportation. Defects may also be overlooked if a section is difficult to inspect or cannot be inspected thoroughly. Similarly, if the structure is difficult to paint, this could be the reason for a poor paint job, which would hasten corrosion of the steel material.

Furthermore, since inspections and repairs are essential if a structure is to be kept functionally sound over a long period, it is also important to consider future maintenance activities such as inspection and repair during the design stage.

10.2 General

10.2.1 Secondary stress

The secondary stress which is caused by the influence of member's eccentricity, node's rigidity, abrupt change in section, floor girder's deflection, floor framing deformation involved in the change of the member length, member deflection under empty weight etc... must be designed to become small as much as possible in structure members.

【Commentary】

Secondary stress is stipulated through reference to [Japan Road Association, 2002]. Although a certain amount of secondary stress is unavoidable, the normal practice is to ignore secondary stress during design calculations and to include its impact within the safety factor. However, effort should be made to minimize the secondary stress in the design of each structural member. The following points are raised in the commentary to [Japan Road Association, 2002] as requiring attention in order to reduce secondary stress as much as possible.

1) Eccentricity of structural member

Eccentricity should be reduced as much as possible when designing the sections of a structure in detail. Even when eccentricity is inevitable, the design must reduce its impact to a minimum.

2) Rigidity of panel joints

Since the secondary stress rises when the rigidity of a panel joint is too large compared to that of each member converging at that joint, panel rigidity should accord with the rigidity of the members. In particular, when designing a truss, secondary bending due to panel joint rigidity

as well as secondary stress caused by eccentric jointing of secondary members to the panel joints and loading on the transverse beams should be taken into account. Since many other countries do not require secondary stress to be checked when the ratio of member height to length, h/l , is less than $1/10$, [Japan Road Association, 2002] states that h/l should ideally be less than $1/10$ (i.e., the minimum slenderness ratio should be about 30).

3) Deflection of deck girder

When the deflection of a deck girder is large, depending on the method used to connect the end parts, out-of-plane deformation of the main girder may occur, leading to higher secondary stress. Also, the deck slab is subjected to an additional bending moment due to deflection of the deck girder. For this reason, deflection of the deck girder must be kept as small as possible.

4) Deformation of deck system caused by change in member length

In the case of a tied arch with a long span, substantial tensile force is exerted on the ties. If the deck system is rigidly connected to the ties, it will stretch with the ties and deform unexpectedly. In such cases, it is best to install an expansion joint in one section of the stringer.

5) Deflection of a member caused by its own weight

The height of a structural member such as a truss member, which is designed based only on longitudinal force, should be greater than its width in order to minimize the bending stress due to its own weight. However, care must be taken since if it is too high the panel joint will become too rigid, and secondary stress will increase.

6) Others

Secondary stress due to friction of movable beam ends, settlement of supporting joints, temperature changes, sudden distortion, and stress concentration due to corrosion must also be taken into consideration, and effort must be made to minimize such stress as much as possible. Extra attention must be paid when high tensile steel is used for a main girder with an exceptionally small beam height because deflection of the cross beam will be greater as it would be less rigid than if ordinary steel were used. As a result, secondary stress due to out-of-plane deformation of the main girder in the case of a steel girder through-bridge and out-of-plane bending of the web member in the case of a truss would be greater. Further, care must be taken when high tensile steel is used for a primary member and mild steel for a secondary member since a variety of secondary deformations and stresses will occur.

10.2.2 Stress concentration

The stress concentration must be considered in design in case it influences the member notch part or structural discontinuity part.

【Commentary】

When there is a weakness because of a significant local concentration of stress due to a notch, measures must be implemented to alleviate this stress concentration by altering the shape or reinforcing with a reinforcing material. Since the impact that stress concentration has on fatigue and brittle failure differs greatly from the impact on loading strength in terms of design direction, one must thoroughly study its impact on failure mode beforehand.

10.2.3 Member with alternate stresses

The member which is subjected alternately to a compressive stress and a tensile stress must be designed safely to each stress.

【Commentary】

This is stipulated by reference to [Japan Road Association, 2002]. The following is the commentary from that document.

For structural members subject to alternating stress, the necessary cross-sectional area for each stress must of course be calculated and the largest of the cross-sectional areas should be used. But at the same time, buckling in response to compressive stress must also be compared. For example, alternating stress arises around the center of the span in the case of the web member of a truss, so this part must be designed for safety against various stresses. Structural members whose stress sign reverses depending on wind direction, such as web members in the transverse groove, are subject to alternating stress; their cross sections must be able to withstand the tensile force due to wind direction and various compressive stresses.

10.2.4 Minimum plate thickness and corrosion

- (1) The minimum thickness of the steel plate is assumed to be the one provided not being transformed when the plate is processed, transported, constructed in site, and considering the damage of the section caused by corrosion and wear-out etc.
- (2) In the case of the corrosion allowance [margin] set up, the plate thickness in the check to safety is assumed to be the one decreased by this margin thickness.

【 Commentary 】

The minimum thickness of structural steel is determined based on the way it is handled during fabrication, transportation, and erection as well as in consideration of corrosion. Generally, the effects of corrosion are not considered for a structure that has undergone anti-corrosion treatment, such as by painting or hot dip galvanizing, but it is taken into consideration during the design stage in the case of underground structures which are in a highly corrosive environment and cannot easily be given an anti-corrosion treatment in the future.

In [Japan Road Association, 2002], the corrosion environment varies according to the anti-rust or anti-corrosion methods implemented and the location of the structure, while handling and fabrication conditions differ for each individual bridge. However, the following regulations are given as a general rule with regard to the minimum thickness of structural steel.

- 1) Structural steel must be 8mm or more in thickness. However, the thickness of the web of I-section steel and channel steel may be reduced to 7.5 mm or more. Closed-section longitudinal ribs, as used as stiffeners for steel decks and box girders, may be reduced to 6 mm or more if the corrosion environment is good or sufficient measures have been taken against corrosion.
- 2) The wall thickness of steel tube to be used as a principal member should be 7.5 mm or greater, while steel tube used as a secondary member must be 6.9 mm or greater in wall thickness.

Material used for guard rails, filler, and pedestrian deck slabs need not follow these regulations.

Refer to "8.2.2 Resistance to Corrosion" for corrosion measures related to the use of weathering steel.

10.2.5 Curved members

It is necessary to do a thorough examination about the additional stress by the curve when the curved member is designed as a straight member.

【 Commentary 】

When 'curved' structural members such as curved I girders and arch rib are designed as polygonal straight members, the additional stress that may occur due to bending in the radial direction of the

curve (because of discrepancies in the angle of longitudinal stress in the members) must be taken into consideration. If this additional stress is sufficiently small compared to the design stress, curved structural members can be designed as multiple straight structural members, as in the case of a curved box girder of large out-of-plane rigidity and arch ribs of large radius of curvature.

10.2.6 Dynamic wind-resistant design of structural members

Because the vibration caused by wind may occur to the following members except bridge girders, the necessity of dynamic wind resistant design must be examined.

- Towers of cable-stayed bridges and suspension bridges
- Cables of cable-stayed bridges and hangers of suspension bridges
- Arch bridges and truss bridges with large slenderness ratios
- Pillar-shaped members with especially large slenderness ratios, such as lighting pillars

【Commentary】

This is stipulated by reference to [Japan Road Association, 2002]. The towers of cable-stayed bridges and suspension bridges do not generally require dynamic wind resistant design as completed systems, although it may be necessary to consider dynamic wind resistance during erection. There have been many cases of vibration occurring in the cables of actual cable-stayed bridges. Vibration may also occur in the suspenders of Langer bridges and the chord members of trusses with a large slenderness ratio, as well as in lamp posts.

The reason for vibration in structural members such as these has not been fully understood and, since it also varies depending on the structure's resistance to wind turbulence, it is difficult to come up with a specific check method. For this reason, the ideal approach is to conduct a vibration study according to [Japan Road Association, 2002] and [Japan Road Association, 1991].

10.3 Frame Members with Axial Tensile Force

10.3.1 Slenderness ratio of members

The maximum slenderness ratio of the tensile member is made to become below the decided maximum slenderness ratio in consideration of the characteristic of the structure.

【Commentary】

In order to ensure that a tensile member has sufficient rigidity to withstand damage during trans-

Table C10.3.1 Maximum slenderness ratio of a tensile member

	AISC [AISC,1978]	Standards for Highway Bridge [Japan Road Association, 2002] Standards for Hydraulic Gate & Penstock Technology [Japan Hydraulic Gate & Penstock Association, 1981]	Standards for Railway Structure [Railway Technical Research Institute, 2000]
Principal Member	240	200	200
Secondary Member	300	240	—

portation and erection as well as to minimize vibration during use, while also ensuring the rigidity of the whole structure, rules have been established regarding the slenderness ratio of such members based on the structure's characteristics and the member's level of importance.

The maximum slenderness ratio of a tensile member as stipulated by [AISC, 1978, Japan Road Association, 2002, Japan Hydraulic Gate & Penstock Association, 1981, and Railway Technical Research Institute, 2000] is as shown in Table C10.3.1. However, these limits do not apply to eyebars, steel bars, and wire rope.

10.4 Frame Members with Axial Compression Force

10.4.1 Width-thickness ratio of plate subjected to compressive stress and stiffened plate

The maximum width-thickness ratio of plate that is subjected to a compressive stress and stiffened plate is assumed to be the one decided in consideration of the steel class, the position of the plate. The strength of the plate that is subjected to a compressive stress and stiffened plate is given in "Chapter 5 Material Strength".

【Commentary】

The principle regarding the maximum width-thickness ratio of plates and stiffeners that are subject to compressive stress due to axial compressive forces and bending moments is outlined here.

- (1) The maximum width-thickness ratio of plates subject to compressive stress as stipulated by [Architectural Institute of Japan, 2002, Architectural Institute of Japan, 1975, Architectural Institute of Japan, 1973, AISC, 1978, ASCE, 1971, Japan Road Association, 2002, Japan Hydraulic Gate & Penstock Association, 1981, and Railway Technical Research Institute, 2000] is as shown in Table C10.4.1.

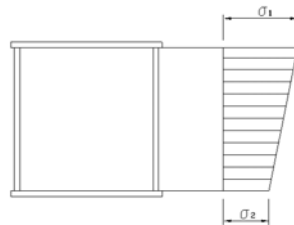

Fig.C10.4.1 Extreme fiber stress of a plate

- (2) The stance of [Japan Road Association, 2002] on the width-thickness ratio of a plate supported at both ends with stiffeners (stiffening plate) is as follows.

When a stiffener that satisfies rule (3) has been placed at regular intervals on a plate supported at both ends and which is subject to compressive stress, the width-thickness ratio of the stiffening plate is expressed by Eq.(C10.4.1). However, the thickness of a plate that is only temporarily subject to stress during erection needs only to satisfy Eq.(C10.4.2).

$$\frac{b}{t} \leq \frac{851fn}{\sqrt{F}} \quad (\text{C10.4.1})$$

$$\frac{b}{t} \leq 85fn \quad (\text{C10.4.2})$$

where, F : specified value of material strength (N/mm²)
 b : total width (mm) of stiffening plate (see Fig.C10.4.2)
 t : plate thickness (mm)

Table C10.4.1 Maximum width-thickness ratio of plate subject to compressive stress

	Type of Steel	Standards for Steel Structure	Guidelines for Plasticity of Steel Structure	Technical Guidelines for High Buildings	AISC-Spec. (Part II)	ASCE Plastic Design	Reference Highway Bridge	Standards for Hydraulic Gate & Penstock Technology	Standards for Railway Structure
b/t of jugged plate such as H cross-section members	SS400 or A36	15.5	10.0	9.0	8.5	8.5	16	12	12.5
	SM490 or A441	13.2	8.5	8.5	7.0	7.0			11
b/t of flange plate of box cross-section members	SS400 or A36	47.8	30.0	32.2	31.6		56f ⁽²⁾		40
	SM490 or A441	40.7	26.0	27.5	26.8		48f ⁽²⁾		34
d/t ⁽¹⁾ of web plate of columns	SS400 or A36	47.8	45.0	43.2	42.8	43.0		40	
	SM490 or A441	40.7	39.0	36.8	36.3	36.4		34	
d/t of web plate of beam	SS400 or A36	71.0	71.0	50.3	68.6	70.0	70	70	70
	SM490 or A441	60.6	61.0	42.9	58.2	59.3	60	60	60

(A36 and others refer to ASTM standard)

NOTE: 1) "d" is all dimensions of the structural member for those regulations other than "Standards for Designing Steel Structure" [Architectural Institute of Japan, 2002], "Technical Guidelines for High Buildings" [Architectural Institute of Japan, 1973] and "Standards for Hydraulic Gate & Penstock Technology" [Japan Hydraulic Gate & Penstock Association, 1981]. Here, "all dimensions" refers to the height of the structural member including the thickness of a flange around the strong axis.

$$2) f = 0.65\phi^2 + 0.13\phi + 1.0, \quad \phi = (\sigma_1 - \sigma_2)/\sigma_1$$

σ_1, σ_2 : the extreme fiber stress at both ends of a plate, but the compressive stress is positive and $\sigma_1 \geq \sigma_2$ (See Fig.C10.4.1.)

n : number of panels created by vertical stiffener ($n \geq 2$)

f : coefficient depending on stress gradient

$$f = 0.65 \left(\frac{\phi}{n} \right)^2 + 0.13 \left(\frac{\phi}{n} \right) + 1.0$$

ϕ : stress gradient, $\phi = (\sigma_1 - \sigma_2)/\sigma_1$ ($0 \leq \phi \leq 2$)

σ_1, σ_2 : extreme fiber stress at each edge of stiffening plate (N/mm²)

However, the compressive stress shall be positive and $\sigma_1 \geq \sigma_2$ (see Fig.C10.4.3)

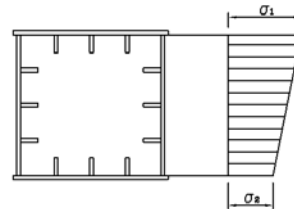
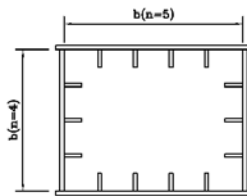

Fig.C10.4.2 Total width of stiffening plate

Fig.C10.4.3 Extreme fiber stress of stiffening plate

(3) The view of [Japan Road Association, 2002] regarding the stiffener designed in (2) for the stiffening plate is as follows:

1) The steel of the vertical stiffener shall be of to the same type as that of the plate to be

reinforced or superior

- 2) The moment of inertia of cross-section $I_l(\text{mm}^4)$ and cross-section area $A_l(\text{mm}^2)$ of one piece of vertical stiffener calculated in section 4) shall satisfy Eq.(C10.4.3) and (C10.4.4), respectively.

$$I_l \geq \frac{bt^3}{11} \gamma_{l,req} \quad (\text{C10.4.3})$$

$$A_l \geq \frac{bt}{10n} \quad (\text{C10.4.4})$$

where, t : thickness of stiffening plate (mm)
 b : total width of stiffening plate (mm)
 n : number of panels created by vertical stiffener ($n \geq 2$)
 $\gamma_{l,req}$: rigidity required of the vertical stiffening plate according to the calculation in section 3)

- 3) The rigidity required of the vertical stiffening plate is calculated as follows:

- a) If $\alpha \leq \alpha_0$ and the moment of inertia of cross-section $I_t(\text{mm}^4)$ calculated in 4) below satisfies Eq.(C10.4.6), then :

$$\left. \begin{aligned} \gamma_{l,req} &= 4\alpha^2 n \left(\frac{t_0}{t} \right)^2 (1 + n\delta_l) - \frac{(\alpha^2 + 1)^2}{n} & (t \geq t_0) \\ \gamma_{l,req} &= 4\alpha^2 n (1 + n\delta_l) - \frac{(\alpha^2 + 1)^2}{n} & (t < t_0) \end{aligned} \right\} \quad (\text{C10.4.5})$$

$$I_t \geq \frac{bt^3}{11} \frac{1 + n\gamma_{l,req}}{4\alpha^3} \quad (\text{C10.4.6})$$

- b) In other cases :

$$\left. \begin{aligned} \gamma_{l,req} &= \frac{1}{n} \left[\left\{ 2n^2 \left(\frac{t_0}{t} \right)^2 (1 + n\delta_l) - 1 \right\}^2 - 1 \right] & (t \geq t_0) \\ \gamma_{l,req} &= \frac{1}{n} \left[\{ 2n^2 (1 + n\delta_l) - 1 \}^2 - 1 \right] & (t < t_0) \end{aligned} \right\} \quad (\text{C10.4.7})$$

where, α : longitudinal and transversal dimension ratio of a stiffener, $\alpha = a/b$
(see Fig.C10.4.4)

α_0 : marginal longitudinal and transversal dimension ratio, $\alpha_0 = \sqrt[4]{1 + n\gamma_l}$

a : transversal stiffener interval (mm)

δ_l : cross-section area ratio of one transversal stiffener, $\delta_l = \frac{A_l}{bt}$

γ_l : stiffness ratio of transversal stiffeners, $\gamma_l = \frac{I_l}{bt^3/11}$

t_0 : plate thickness of stiffener, $t_0 = \frac{b\sqrt{F}}{426fn}$

F : specified value of material strength (N/mm^2)

f : coefficient depending on stress gradient shown in (2)

- 4) The moment of inertia of the stiffener's cross section is obtained by the following rule:

- a) If a stiffener is located on one edge of the plate to be reinforced, then it is the moment of inertia of the cross section with respect to the surface on the stiffener side of the plate to be stiffened.
- b) When stiffeners are located on both edges of the plate to be reinforced, then it is the moment of inertia of the cross section with respect to the neutral surface of the plate to be stiffened.

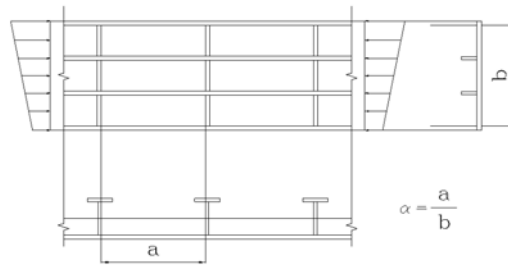

Fig.C10.4.4 Longitudinal and transversal dimension ratio of stiffener

10.4.2 Perforated plate

The minimum plate thickness of the perforated plate that is subjected to a compressive stress is decided in consideration of the distance between welding lines, the width from welding line to the hole.

【Commentary】

It is common to occasionally use structural members with perforations for operational purposes. In such a case, local buckling may occur if the perforated plate is too thin. [Japan Road Association, 2002] stipulates as follows in such cases.

- (1) The minimum plate thickness for perforated plates and the maximum distance between the inner weld line and the edge of a perforation is as shown in Table C10.4.2:

Table C10.4.2 Perforated plate

Steel type	Minimum plate thickness (mm)	Maximum width between inner weld line and edge of perforation (mm)
SS400, SM400, SMA400W	$d/50$	$13 t$
SM490	$d/40$	$11 t$
SM400Y, SM520, SMA490W	$d/40$	$11 t$
SM570, SMA570W	$d/35$	$10 t$

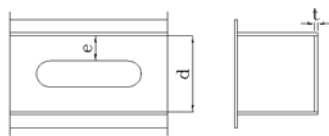

Fig.C10.4.5 Perforated plate

where, t : thickness of perforated plate (mm)
 d : distance between inner welding lines (mm)
 e : maximum distance between inner weld line to edge of perforation (mm)

- (2) The length of perforation measured in the stress direction must be less than double the width of perforation.
- (3) The length of plate between two perforations measured in the stress direction must be greater than d . However, the distance from the rim of perforation at the edge and the edge of the perforated plate must be greater than $1.25d$.
- (4) The radius of curvature of the rim of the perforation must be greater than 40 mm. Furthermore, in [Railway Technical Research Institute, 2000] it is stated that the minimum thickness of a perforated plate should be $d/50$ for a compression member and $d/60$ for a tension member based on experience.

10.4.3 Influence of eccentric bending moment

The influence of bend moment by eccentric is considered when angle steel, T steel etc is installed only in one side of the gusset plate.

【Commentary】

A compression member comprising an angle or T section should ideally be checked according to "Chapter 6 Necessary Capability and Checking for Safety" as a member that is subject to bending and compression by calculating the effect of eccentricity on the bending moment. However, to check every member in this way would make calculation very complicated, so an abbreviated calculation may be used. The view of [Japan Road Association, 2002] as regards the abbreviated calculation is as follows.

Design can follow Eq.(C10.4.8) when the compression member comprises an angle or T section whose flange is connected to the gusset plate, as in Fig.C10.4.6.

$$\frac{P}{A_g \sigma_{cug} \left(0.5 + \frac{l/r_x}{1,000} \right)} \leq 1.0 \quad (\text{C10.4.8})$$

- where, P : axial compressive force (N) with safety factor already taken into consideration
 A_g : total cross-sectional area of member (mm^2)
 l : effective buckling length (mm)
 r_x : radius of gyration of area (mm) around the axis passing through the gravity center of a cross-section and parallel to the gusset surface (x-axis of Fig.C10.4.6)
 σ_{cug} : compressive strength (N/mm^2) as calculated using the following equation using l/r_x

$$\sigma_{cug} = \begin{cases} 1.0F & (\lambda \leq 0.2) \\ (1.109 - 0.545\lambda)F & (0.2 < \lambda \leq 1.0) \\ \frac{1.0}{(0.777 + \lambda^2)}F & (1.0 < \lambda) \end{cases}$$

- where, λ : slenderness ratio parameter $\lambda = \frac{1}{\pi} \sqrt{\frac{F}{E}} \frac{l}{r_x}$
 F : specified value of material strength (N/mm^2)
 E : Young's modulus of steel (N/mm^2)

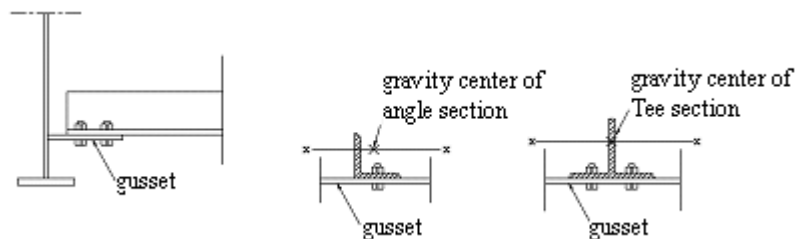

Fig.C10.4.6 Compression member comprising angle or T section

10.4.4 Slenderness ratio of structural members

The slenderness ratio of the compressive member is made to become below the maximum width - thickness ratio in which the characteristic of the structure is considered.

【Commentary】

Table C10.4.3 shows the maximum slenderness ratio of a compression member as stipulated by [AISC, 1978, Architectural Institute of Japan, 2002, Japan Road Association, 2002, Japan Hydraulic Gate & Penstock Association, 1981, Deutscher Normenausschuss, 1990, BSI, 1980, and Railway Technical Research Institute, 2000].

Table C10.4.3 Maximum slenderness ratio of compression member

Source	Maximum allowed slenderness ratio	Comment
AISC	240	principal member
	300	bracing, secondary member
Standards for Steel Structure	200	compression member
	250	compression member
Reference for Highway Bridge Standards for Hydraulic Gate & Penstock Technology	120	principal member
	150	secondary member
	150	secondary member
DIN4114	250	compression member
BS5400	180	member subject to fixed load
	250	member subject to wind
Standards for Railway Structure	100	primary compressive member
	120	primary compressive member

10.5 Frame Members with Bending**10.5.1 Width-thickness ratio of plate subjected to compressive stress and stiffened plate**

The maximum width-thickness ratio of plate that is subjected to a compressive stress and stiffened plate is assumed to be the one decided in consideration of the steel class, the position of the plate.

【Commentary】

This is in accordance with 10.4.1.

10.5.2 Effective section

The bending rigidity in the case of calculating deflection, statically indeterminate force etc is defined in term of the effective section corresponding to the effective width of flanges.

【Commentary】

This is stipulated by reference to [Japan Road Association, 2002]. There is no need to consider bolt holes when looking at the cross-sectional performance of a member in structural analysis, but flexural rigidity must be calculated by taking the effective width into consideration.

10.5.3 Overlapping flange

In the cover plate which acts as flange made by overlapping steel plates, the detailed structure which is considered 1) welding property stress flow, 2) stress distribution of girder, 3) fatigue, etc

is adopted.

【Commentary】

This is stipulated by reference to [Japan Road Association, 2002]. When the cover plate receives direct loading or if special attention to fatigue of the cover plate is required, the requirements outlined by [Railway Technical Research Institute, 2002] should be used.

A cover plate used as a flange by superimposing a steel plate on it should, in principle, consist of one outer flange whose design is governed by the requirements given below. (Refer to Fig.C10.5.1.)

- 1) The thickness of the outer flange should be less than 1.5 times the thickness of the inner flange

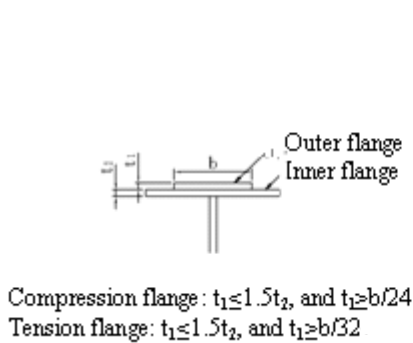

Fig.C10.5.1 Thickness of outer flange

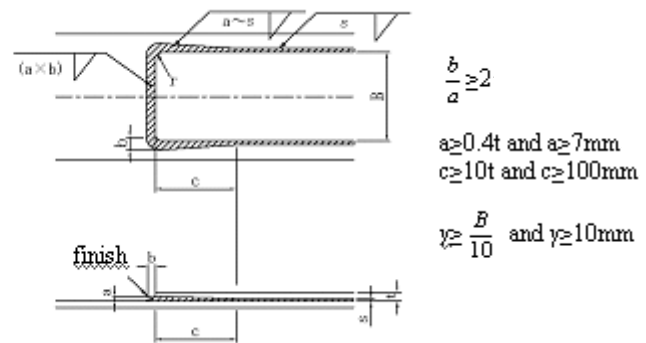

Fig.C10.5.2 Welding details of the ends of outer flange

- 2) The thickness of an outer flange used as a compressive flange should be greater than 1/24 of the outer flange's width.
- 3) The thickness of an outer flange used as a tension flange should be greater than 1/32 of the flange's width.
- 4) The length of the outer flange should be greater than the value obtained by adding 1 m to twice the depth (m) of the girder.
- 5) The total length between the ends of the outer flange shall be greater than the theoretical value by 30 cm, and greater than 1.5 times the width of the outer flange.
- 6) An outer flange used as a tension flange should be of length such that the stress in the flange calculated using the sectional area excluding the outer flange is less than 90% of the strength of the steel member, allowing for a safety factor.
- 7) The ends of the outer flange should be continuously fillet welded with unequal leg length. Welding details are shown in Fig.C10.5.2.

10.5.4 Effective section for shear forces

The effective section which bears shear forces is decided appropriately according to the section shape of the member.

【Commentary】

The commentary of [Japan Road Association, 2002] assumes that the "shear forces in a cross section caused by bending have a distribution that flows along the center line of each plate in the case of a thin-walled beam, thus exact values are given by the so-called shear flow theory". However, it is also stated that "in the case of a general plate girder, the greater part of the shear forces caused by bending is withstood by web plates, and since little error from the above theory is expected even if one assumes

a uniform distribution in the web plates it may be possible to use the simple formula (shear forces caused by bending)/(total area of cross sections of web plates)".

The conclusion here is that, regarding whether to apply rigid shear flow theory or the simple method to calculate the effective section withstanding shear forces, an appropriate judgment is to be made by the engineer in charge according to the cross-sectional shape of the structural member.

10.6 Steel Pipes

10.6.1 Radial thickness ratio

The maximum radius thickness of steel pipes is decided in consideration of local buckling. The strength of steel pipe members is given in "5.5 Steel Pipes Strength".

【Commentary】

The strength characteristics of steel tubes are greatly affected by the diameter to wall-thickness ratio (D/t). Since local buckling easily occurs in structures with a relatively large D/t , such as steel piers and pipe arches, stiffeners and diaphragms are installed. Meanwhile, stiffeners are not normally used when using small steel tubes with relatively small D/t , such as in offshore jacket structures.

The requirements for tubular steel structures in [Architectural Institute of Japan, 2002 and Architectural Institute of Japan, 1980] are as follows.

$$\frac{D}{t} \leq \frac{23500}{f} \quad (\text{C10.6.1})$$

where, D : nominal external diameter of steel tube (cm)

t : tube thickness(cm)

f : specified value of material strength (N/mm²)

10.6.2 Stiffened member

The structure which can prevent a buckling or a local transformation caused by shearing and torsion is adopted in steel pipe members.

【Commentary】

This is stipulated by reference to [Japan Road Association, 2002]. In principle, ring-shaped stiffeners or diaphragms should be fitted into steel tubes to prevent buckling due to shear and torsion, as well as local deformation. The requirements for stiffeners according to [Japan Road Association, 2002] are as follows.

- (1) Maximum spacing between reinforcement components: in principle, ring-shaped stiffeners or diaphragms should be fitted into steel tubes with a maximum spacing of three times the outer diameter of the tube. However, when the tube is within $R/t \leq 30$ this can be omitted.
- (2) Hardness of ring-stiffener: the width and thickness of the ring-stiffener's juttred pillar must each satisfy Eq.(C10.6.2).

$$b \geq \frac{d}{20} + 70$$

$$t \geq \frac{b}{17} \quad (\text{C10.6.2})$$

where, b : width of ring-stiffener's juttred pillar (mm)
 d : thickness of ring-stiffener (mm)
 t : outer diameter of steel tube (mm)

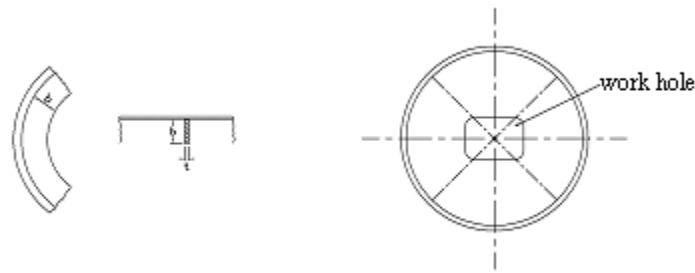

Fig.C10.6.1 Ring stiffener Fig.C10.6.2 Diaphragm

10.6.3 Node structure

The node part and shoe parts at which the concentrated load works must be the structure which prevents a local transformation and transmits the stress smoothly.

【 Commentary 】

This is stipulated by reference to [Japan Road Association, 2002]. Although steel tubes are very resistant to axial compressive force and torsion, local deformation occurs when they are subjected to concentrated loading. Therefore, panel and bearing points should, in principle, be reinforced with ring stiffeners or diaphragms. In [Japan Road Association, 2002], the requirements regarding the degree of local deformation when a ring stiffener is used are as follows.

(1) The degree of deformation at a panel point must satisfy Eq.(C10.6.3).

$$\delta \leq \frac{R}{500} \quad (\text{C10.6.3})$$

where, δ : degree of deformation at panel point (mm)
 R : radius of steel tube (mm)

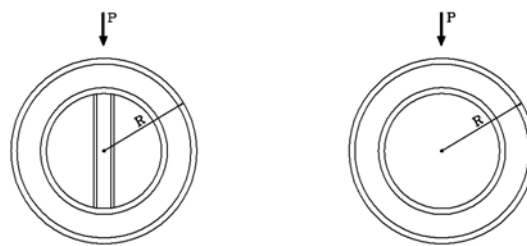

Fig.C10.6.3 Shape of ring stiffener

(2) The degree of deformation at a panel point of a ring stiffener must satisfy Eq.(C10.6.4).

$$\begin{aligned} \text{When using together with support} & \quad 0.007 \frac{PR^3}{EI} \\ \text{When using only ring stiffener} & \quad 0.045 \frac{PR^3}{EI} \end{aligned} \quad (\text{C10.6.4})$$

where, P : operating load (N)
 I : Ring stiffener's moment of inertia of cross-section (mm²)
 E : Young's modulus of the tube (N/mm²)

- (3) The steel tube's effective width, λ , when calculating the ring stiffener's moment of inertia of cross section should be according to Eq.(C10.6.5).

$$\lambda = 0.78\sqrt{Rt} \quad (\text{C10.6.5})$$

where, R : steel tube's effective width (mm)
 t : thickness of steel tube (mm)
 λ : effective width

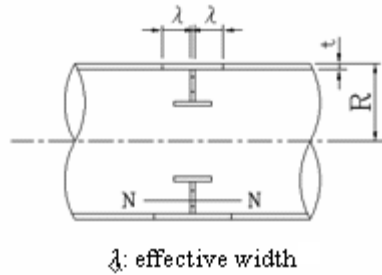

Fig.C10.6.4 Effective width of steel tube

10.6.4 Curved tube

When the curved tube is used, the safety against additional stress at the curved part and the local buckling must be determined.

【Commentary】

This is stipulated by reference to [Japan Road Association, 2002]. However, when a member is composed of a bent tube and the angle of the bend satisfies Eq.(C10.16), the tube can be regarded as a straight member in design. In Eq.(C10.6.6) the additional stress due to the bent member has been set as being less than 2% of the stress of the straight member

$$\theta = 0.04 \frac{d}{L} \quad (\text{C10.6.6})$$

where, θ : angle of bend (radian). In the case of a circular arch, $\theta = \frac{L}{R_a}$
 d : diameter of steel tube (mm)
 L : length of straight member (mm)
 R_a : diameter of curvature of arch (mm)

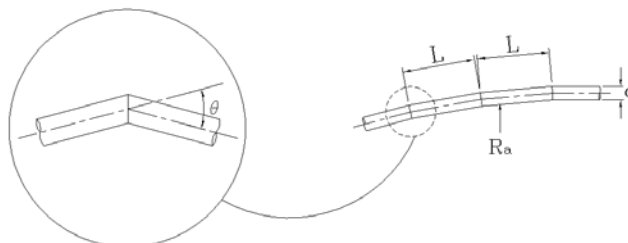

Fig.C10.6.5 Bent tube

10.6.5 Steel pipe connections

(1) The joint which connects steel pipes should be able to ensure the stress transmission, to prevent a local transformation, and to secure toughness.

(2) When a steel pipe and a steel pipe are axially connected, the direct joint fitted by the high tensile bolt or the welding is used.

However, the demand performance shown in "Chapter 11 The joint" is satisfactory, flange joint is acceptable.

(3) When a steel pipe is connected to a member with different member axis to each other, gusset joint and branching joint is used.

【Commentary】

This is stipulated by reference to [Japan Road Association, 2002].

(1) Direct connections

In principle, when tube sections are directly joined using high-strength bolts or rivets, the spacing between these high-strength bolts or rivets should be uniform around the circumference, with non-varying line intervals and pitches. Furthermore, the splitting of a restrainer plate should, in principle, be at less than four points.

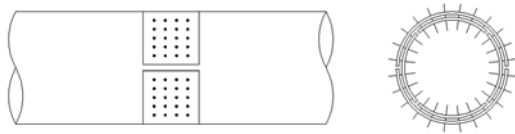

Fig.C10.6.6 Example of 4-way splitting of a restrainer plate

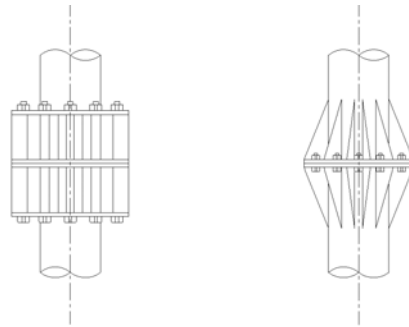

Fig.C10.6.7 Flange connection

(2) Flange connections

In principle, flanges should be joined either with double flange connections or ribbed flange connections. When a rib-less flange connection is used, thorough verification of such possibilities as flange deformation must be carried out.

(3) Gusset connections

(a) When a gusset plate is attached to a main tube longitudinally, in principle either a through gusset should be used or the main tube should be reinforced with ribs (Fig.C10.6.8 (a) (b)).

(b) When either a gusset is to be attached to the tube vertically or a stiffener rib is to be fitted at a panel point with no ring stiffener, the attachment width should be such that the center angle of the steel tube is more than 120° (Fig.C10.6.8 (b) (c)). Furthermore, in instances such as that shown in Fig.C10.6.8 (c), the gusset plate should be reinforced with ribs as needed. Also, the end of the gusset plate on the side of a branch tube should be finished to a smooth surface after box welding (Fig.C10.6.8 (a)).

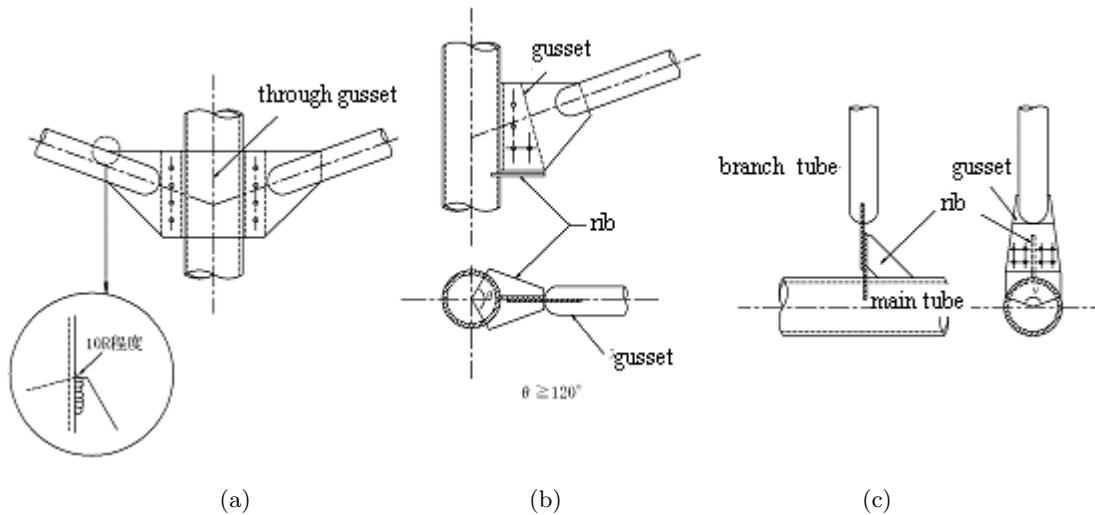
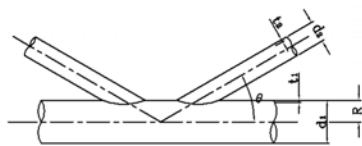

Fig.C10.6.8 Gusset connection

(4) Branch connections

Branch connection of steel tubes shall meet the following requirements (Fig.C10.6.9)

- The wall thickness of the main tube must be more than $R/30$ and, in principle, greater than the branch tube's wall thickness.
- The outer diameter of the branch tube should be more than $1/3$ of the main tube's outer diameter.
- The angle between the two tubes should be more than 30° .



- $t_1 \geq t_2, t_2 \geq \frac{R}{30}$
- $d_2 \geq \frac{1}{3} d_1$
- $\theta \geq 30^\circ$

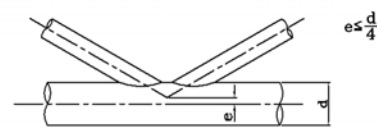

Fig.C10.6.9 Branch connection

Fig.C10.6.10 branch connection with eccentricity

- There should be no eccentricity in the axis of either tube. However, if this is unavoidable because the branch tube is a secondary member, eccentricity of up to $1/4$ in the direction of the branch tube is allowed (Fig.C10.6.10).
- The ends of the branch tube should be cut using an automatic tube cutter.

References in Chapter 10

- Architectural Institute of Japan(1973) : Technical Guidelines for High Buildings.
 Architectural Institute of Japan(1975) : Guidelines for Designing Plasticity of Steel Structure .
 Architectural Institute of Japan(1980) : Guidelines and Handbook for Designing and Constructing Steel Tube Structures .
 Japan Hydraulic Gate & Penstock Association(1981) : Standards for Hydraulic Gate & Penstock Technology .
 Japan Road Association(1991) : Handbook for Wind Resistant Design of Road Bridges .
 Public Works Research Institute, Ministry of Construction(1994) : Recommendations for Design and Construction of Unpainted Weather Resistant Bridges (drafted revision) .
 Railway Technical Research Institute(2002) : Design Standards for Railway Structures and Commentary, Steel and Composite Structures .
 Japan Road Association (2002) : Specifications for Highway Bridges and Commentary, II Steel Highway Bridges Volume .
 Architectural Institute of Japan(2002) : Design Code for Steel Structure.
 AISC(1978) : Specifications for Design, Fabrication and Erection of Structural Steel for Buildings.

ASCE(1971) : Plastic Design in Steel, ASCE M&R, No.41.

BSI (1980) : BS5400.

Deutscher Normenausschuss(1990) : DIN 18800-2.

Chapter 11 Joints

11.1 General

Joints shall be of a design that remains safe for all actions anticipated during erection and throughout the design working life.

【Commentary】

Joints are one of the most important components of structures. They link structural members and structural elements together to build up a structure. Joints should be of a design that meet the various performance requirements specified in this code for all actions anticipated during erection and throughout the design working life of the structure, just as for the structural members and elements themselves. In particular, the performance requirements considered in the case of joints are those related to structural safety, such as load-carrying capacity and deformability, public safety, durability, and so on. One example of a public safety requirement is the dropping out of a high-strength bolt from underneath a bridge due to delayed fracture. Durability performance, such as fatigue/corrosion resistance, is also important for joints, but this is dealt with in detail in Chapter 8 deals. Accordingly, this chapter deals only with the safety of joints.

In the case of road and rail bridges, joints are designed to have adequate strength for general actions. But where the forces are small, joints are designed to have a strength that is a multiple of that of the joined members, using a specific ratio such as 75%. This means that joints are specifically designed with a strength and rigidity so as not to be weak points in the structure. These days, with developments in FE analysis and computer technology, research into semi-rigid connections is moving forward, focusing on the role of joints in providing seismic resistance. Consequently, it is expected that new types of joints reflecting this work will come into use. Considering this, it is desirable that deformability should be added as a verification requirement for joint safety to complement load-carrying capacity.

11.2 Joint Safety Requirements

Requirements relating to the load-carrying capacity and deformation of joints shall be specified adequately so as to ensure the safety of the structure under the influence of all actions anticipated during erection and throughout the design working life.

【Commentary】

In specifying the requirements relating to joint load-carrying capacity and deformation, the function of the joint in the structure should be taken into account so as to ensure safety during erection and throughout the design working life. If the function of the joint is different in the structure, the requirements are properly different.

If the joint does not need to undergo large deformation, a strength requirement for the rigidity of the joint, such as 75% of the strength of the joined members or 50% of the load-carrying capacity of the joined members, determined using characteristic material values might be substituted for deformation requirements so as to maintain a certain joint rigidity under earthquake/construction/accidental/secondary forces. It is important to keep a balance of rigidity throughout the whole structure.

11.3 Verification of Joint Safety

The safety of joints shall be verified by means of the following methods to confirm that the requirements of 11.2 are met during erection and throughout the design working life.

(1) Load-carrying capacity

It must be confirmed that the resistance of joints is sufficiently greater than the actions applied during erection and throughout the design working life to ensure the required load carrying capacity.

(2) Deformation

Standard procedure is to confirm that joint deformation during erection and throughout the design working life under all anticipated actions is less than the deformation requirements in consideration of required deformation capacity and also sufficiently below the safe degree of deformation.

【Commentary】

Joint safety should be verified by the partial factor method specified in 6.3 'Verification for Safety'. But verification using other methods may also be applicable if it is ensured that the method is suitable for verification. Some of the other methods available for verification are as follows: evaluation of the probability of exceeding the limit state; methods based on the reliability index; and methods based on experimental and analytical results.

Generally, joints are designed in full consideration of the novelty of the connection method. This clause only specifies the principle of verification, so conventional verification methods might be adopted. However, it should be noted that conventional design methods for joints do not allow for large deformation of joint sections.

11.4 General Principles for Joints

11.4.1 Member joints

Structural details of joints between members shall be designed so as to satisfy the following requirements.

- (1) Smooth transfer of load
- (2) Avoidance of eccentricity
- (3) Avoidance of undesirable stress concentration
- (4) Avoidance of undesirable residual stress and secondary stress

【Commentary】

This clause indicates the principles of joint design in this code.

11.4.2 Mixed welded, high-strength bolted, and bolted connections

Where there is a mix of welded, high-strength bolted, and bolted connections, the propriety of such joints shall be judged in consideration of the load-transfer mechanism.

【Commentary】

Because the load-transfer mechanism becomes very complex when welded, high-strength bolted, and bolted connections are mixed, careful attention should be paid and clauses 11.1 to 11.3 should be

followed in using such connections.

The commentaries given in various Japanese design codes are summarized below.

(1) Welded and high-strength bolted friction-type connections

- 1) Since the relationship between stress and strain at the connection point in a high-strength bolted friction-type joint is almost the same as that of the connected members, groove welding and a high-strength bolted friction-type connection can operate together to transfer the action force. Where a fillet weld in the stress direction is mixed with a high-strength bolted friction-type connection, both connections can transfer the action force because the slip between splice plate and connected plate in the bolted connection is almost the same as that of the fillet weld. However, in cases where such a mixed connection is long, the edge gap becomes large and yielding can begin. In such cases, the stress distribution at the connection and the load-carrying capacity of the whole joint should be considered sufficiently.
- 2) The mixed usage of fillet welding perpendicular to the stress direction and a high-strength bolted friction-type connection must not be used in principle, since there is not enough information about the load-transfer and deformation mechanisms of this combination.

(2) Welded and high-strength bolted bearing-type connections

Welded and high-strength bolted bearing-type connections must not be used together in principle, since in a bearing-type connection the load is transferred through shear deformation of the bolt, so the relationship between applied force and deformation of the bearing is significantly different from that of the weld.

(3) Welded and normal bolted connections

Welded and normal bolted connection must not be used together in principle for the same reason that the combination of welded and high-strength bolted bearing-type connection is not allowed. That is, there is a great difference in load-transfer mechanism between the weld and the bolted connection.

This combination could be used, however, if the normal bolted connection does not transfer the action force in design.

(4) High-strength bolted and normal bolted connections

Where high-strength bolted and normal bolted connections are used together, the normal bolted connection cannot transfer the action force due to the difference in load-transfer mechanism between the two connection types.

11.5 Welded Connections

11.5.1 Requirements

- (1) Welded connections that transfer load shall not be subject to failure under all actions anticipated during the design working life and should transfer forces securely and smoothly between members/elements.
- (2) Weldability shall be taken into consideration.

【 Commentary 】

- (1) This clause gives the requirements for welded connections to ensure that they do not fail under all actions anticipated during the design working life of the structure.

Some damage might be found at welded connections that transfer load before they reach the design limit state with certain welding methods/ conditions. It is important to realize that welded connections must transfer the forces securely and continuously between members/elements and

should not fail until the design limit state. In general, to prevent failure at welded connections, the strength and elongation characteristics of the welding material used for the connection are superior to those of the connected material. However, the heating necessary to create a welded joint causes a heat-affected zone to form, where material properties may change; in particular, embrittlement and softening may occur. For this reason, the welding materials and the materials to be joined by welding, the connection type, and the welding method should be selected appropriately.

A welded connection that transfers load should deform along the design deformation curve while securely and continuously transferring the load. In cases where a welded connection is designed for a nominal applied force, it should be noted that a local stress concentration might occur at the welded connection or the welded connection might be a weak point if the structure is subjected to abnormal applied forces such as in an earthquake or during construction due to its lower rigidity.

In the design of steel bridge piers, it is now common that deformation capacity is provided for in order to secure earthquake resistance. In the case of a design which allows for plastic deformation of welded connections, the connections should be detailed appropriately to assure adequate fusion. Further, since the balance of strength between the welded materials and the weld itself is also very important, an examination by experiment and FE analysis should be carried out. Details are given in the Seismic Design section of this code.

- (2) Since the performance of a welded connection depends on the welding process, weldability must be taken into consideration. In order to ensure that welding is carried out appropriately, the connection details should be designed in consideration of ease of welding. For example, where there is a welded connection at the corner of a steel bridge pier, extremely thick steel plate has to be welded and it is difficult to locate defects. That is, the ease of weld quality control must be taken into consideration.

11.5.2 Safety verification of welded connections

- (1) The safety verification of welded connections that transfer load shall be confirmed such that their resistance exceeds all actions and does not fall far below the resistance of the weld material and the member itself.
- (2) Verification of weldability shall be confirmed through due consideration.

【 Commentary 】

- (1) The safety verification of load-transferring welded connections basically conforms with that for frame members (6.3.1.1) and joints (11.3). In general, the strength of a welded connection is higher than that of the welded members and there are few cases of weld failure. However, embrittlement and softening are possible in the heat-affected zone, so it should be confirmed that materials are selected properly, an appropriate connection type is adopted, and that weldability is properly considered. For example, regarding embrittlement, it is important to: ① select suitably tough materials to be welded and for the weld itself; and ② check for appropriate heat input and interpass temperature. As for softening, it is important to: ① consider the chemical composition and mechanical properties of the materials; ② develop connection details with less constraint; and ③ prescribe a welding procedure taking into account welding strain. There is a great variety of welded connections; the safety of chosen methods should be examined through experiments and weldability tests.

Full penetration groove welds, partial penetration groove welds, and continuous fillet welds are used for welded connections that transfer load. Discontinuous fillet welds suffer from certain

problems such as blow holes at weld beginnings and ends, weld cracking, stress concentrations at crater, and difficulty in preventing rust. However, discontinuous fillet welding might be used in cases where it is confirmed that such problems can be solved. Plug welds and slot welds should not be used for welded connections that transfer load because it is difficult to ensure adequate melting and slug inclusion defects tend to occur. However, considering ability and welding strain, some penetration groove welding and fillet welding is suitable.

Verification examples using the partial factor design method are given below.

1) Safety verification of welded connections subject to axial force/shear force

In the case of a full-penetration groove weld, as the strength can be assumed to be equal to that of the connected members, verification of the members subjected to axial force/shear force, as given in clause 6.3.1.1.(1), is adequate verification of the welded connection. In the case of fillet welds and partial-penetration welds subjected to axial force/shear force, the shear strength at the throat cross section should be used.

$$\gamma_i \frac{P_{sd}}{P_{rd}} \leq 1.0 \quad \text{or} \quad \gamma_i \frac{V_{sd}}{V_{rd}} \leq 1.0 \quad (\text{C11.5.1})$$

where , γ_i : structural factor

P_{sd}, V_{sd} : design axial force and design shear force of the welded connection

P_{rd}, V_{rd} : design axial resistance and design shear resistance $(= \frac{\tau_{ud}}{\gamma_b} \sum a l)$

$(a$: effective throat thickness of weld ,

l : effective weld length design strength of weld)

τ_{ud} : design strength of the welded connection

2) Safety verification of welded connections subjected to bending moment

In the case of a full-penetration groove weld, as the strength can be assumed to be equal to that of the connected members, verification of the members subjected to bending moment, as given in clause 6.3.1.1.(2), is adequate verification of the welded connection. In the case of a fillet weld, the expanded cross section at the throat, as shown in Fig.C11.5.1, should be used. Furthermore, in case of partial-penetration welds, the same verification as for fillet welds can be used in practical design.

$$\gamma_i \frac{M_{sd}}{M_{rd}} \leq 1.0 \quad (\text{C11.5.2})$$

where , γ_i : structural factor

M_{sd} : design bending moment of the welded connection

M_{rd} : design bending resistance $(= \left(\frac{I}{Y_t} \right) \frac{\tau_{ud}}{\gamma_b})$

τ_{ud} : design strength of the welded connection

I : moment of inertia at the neutral axis for expanded cross section
for weld connection

Y_t : distance from neutral axis of expanded cross section for weld connection

Where full-penetration groove welding is used for the flange plate and partial-penetration groove welding/fillet welding is used for the web plate, the deformability and stress level at the groove weld connection are different from those at the partial-penetration groove weld/fillet weld connection. Therefore, when full-penetration groove welding is used together with fillet welding in this way, the fillet weld should be disregarded in the bending moment verification.

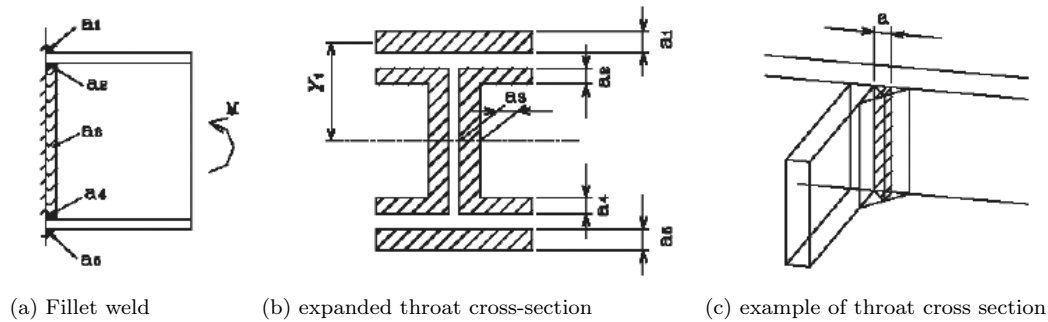

Fig.C11.5.1 Fillet weld connection subjected to bending moment

- 3) Safety verification of welded connections subjected to axial force, bending moment, and shear force simultaneously

In the case of a full-penetration groove weld connection, the resistance of the connection is assumed to be equal to that of the connected members, so the resistance of the connection is verified in accordance with clause of 6.3.1.1(5), which prescribes the combined stress verification when a member is subjected to bending moment and shear force simultaneously. In the case of a fillet weld, resistance is verified by the shear strength of the throat cross section. The expression used for verification is equation 11.5.3 below. In this equation, the coefficient $\phi=1.21(= 1.1^2)$ for the combination of normal stress and shear stress is not taken into account because only the combination of shear stresses is verified. This equation may be applied also to partial penetration welds in practice.

$$\gamma_i^2 \left\{ \left(\frac{P_{sd}}{P_{rd}} + \frac{M_{sd}}{M_{rd}} \right)^2 + \left(\frac{V_{sd}}{V_{rd}} \right)^2 \right\} \leq 1.0 \tag{C11.5.3}$$

where , γ_i : structural factor

The effective throat thickness and effective length for verification of welded may be taken as in 4) and 5) below.

- 4) Effective thickness

- ① The effective thickness of a weld that transfers load should be the theoretical throat of weld.
- ② The thickness of the theoretical throat of each type of welding connection is shown below.
 - The theoretical throat of a full-penetration groove weld is the thickness of the connected members regardless of the bead finish (Fig.C11.5.2). When the thickness of the members is different, the thickness of the thinner member is taken as the theoretical throat thickness.

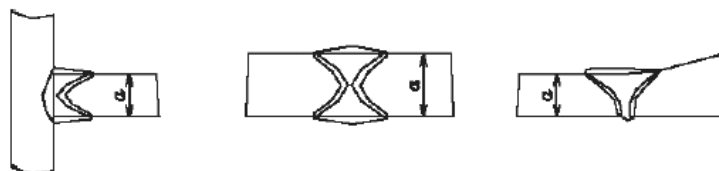

a : theoretical throat thickness

Fig.C11.5.2 Theoretical throat thickness of full-penetration groove weld

- A partial-penetration weld should be designed so that tensile force is not applied perpendicular to the bead direction. The theoretical throat thickness that resists shear force is the depth of penetration, as shown in Fig.C11.5.3.
- The theoretical throat thickness of a fillet weld is the distance from the base of the

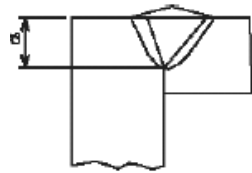

a : theoretical throat thickness

Fig.C11.5.3 Theoretical throat thickness of partial-penetration weld

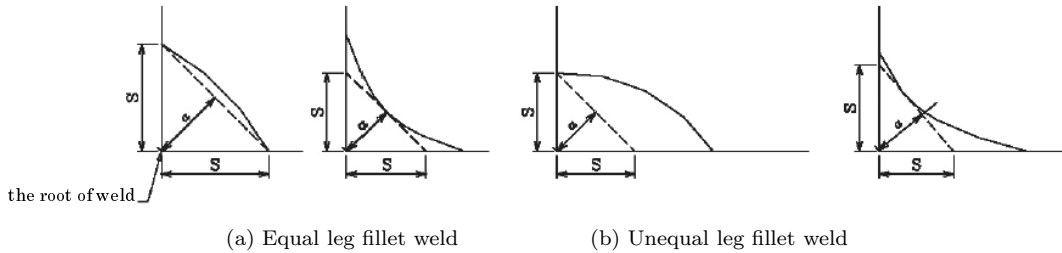

Fig.C11.5.4 Theoretical throat thickness of fillet weld

isosceles triangle to the root of the weld, as shown in Fig.C11.5.4.

- The theoretical throat thickness of a partial-penetration weld overlapped by a fillet weld can be the same as the theoretical throat of the fillet weld.

The theoretical throat thicknesses of a partial-penetration weld is shown in Fig.C11.5.5. The effective throat thickness has been calculated for a standard groove [Japanese Society of Steel Construction, 1997]. In that case, the effective throat thickness was the value obtained by subtracting 3 mm from the theoretical throat for a groove with a small angle, except in the case of submerged arc welding (SAW). This idea was appropriate and gave a result on the side of prudence when it was specified in 1977; arc welding (SMAW) was a popular welding process at that time. However, shielding gas welding (GMAW), which requires more penetration than covered arc welding, is more common now. Consequently, it is necessary to reexamine the method of calculating effective throat thickness. The method of calculating effective throat thickness for shielding gas welding is shown in Japanese Society of Steel Construction, 1997. The calculation method given in table C11.5.1 might be applicable in this code taking into consideration of these latest research results.

Table C11.5.1 Calculation method for effective throat thickness

	SMAW	SAW	GMAW	
			solid wire	Flux-cored wire
$45^\circ \geq \theta \leq 60^\circ$	Te-3mm	Te	Te	Te-2mm
$60^\circ \geq \theta \leq 70^\circ$	Te	Te	Te	Te-1mm

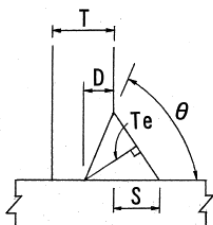

$$D \geq 2 \cdot \sqrt{T}$$

$$(\theta = 45^\circ \sim 70^\circ)$$

$$S = D(\sec\theta - 1)$$

$$Te = (D \cdot \sec\theta \cdot \cos(\theta/2))$$

Fig.C11.5.5 Theoretical throat thickness of partial-penetration weld overlapped with a fillet weld

- 5) The weld should have an effective length as shown in below.
 - ① The effective weld length should be equal to the theoretical throat thickness. If penetration is insufficient because the cross section of the weld metal is imperfect at the

weld start point, as shown in Fig.C11.5.6, it might not be possible to transfer the load correctly. Further, defects such as cracks in the crater at the weld end point easily occur. For this reason, these parts of the weld should be excluded from the determination of the effective length.

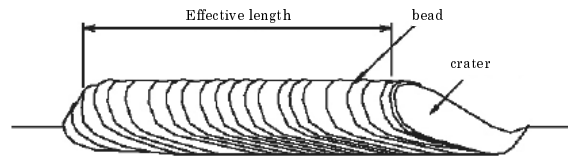

Fig.C11.5.6 Effective length of weld

- ② The effective length must be the projected length in the stress direction, as shown in Fig.C11.5.7, when the weld line is not perpendicular to the stress direction in the case of a full-penetration groove weld. Moreover, the weld end tab should be used for an important connection that transfer load.
- ③ Load transfer is not clear when box welding is carried out with fillet welds because the stress orientation changes at the corners. Additionally, it is difficult to eliminate the influence of the start point of the weld/crater. Accordingly, these parts of the weld should be excluded from the determination of the effective length, as shown in Fig.C11.5.8.

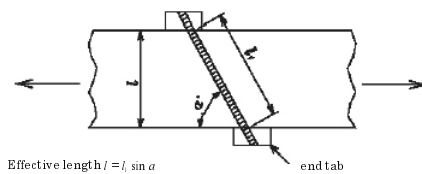

Fig.C11.5.7 Effective length of weld

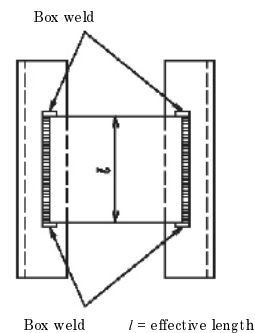

Fig.C11.5.8 Effective length of weld

- (2) Various restrictions on fabrication work, such as a need for field welding, limited work space, and a limited range of welding positions, mean that a good weld may not be obtained. It is important to ensure a suitable secure fabrication environment while paying careful attention to working conditions.

This attention to fabrication is necessary since cracking may occur where a welding takes place under restricted conditions. A great deal of caution is also needed where discontinuous fillet welding is used for decorative laminates or metal form welding, since defects can easily arise.

The means of weld quality assurance must be considered in advance.

11.5.3 Size of fillet welds and geometry and dimensions of welded connections

- (1) The size and minimum effective length of each fillet weld shall exceed each the required design value in every case. The size of a fillet weld, taken as the heat-affected zone, shall be minimized.

- (2) The geometry and dimensions of welded connections shall be designed in consideration of smooth load transfer, avoidance of undesirable secondary stress and deformation, and fatigue.

【Commentary】

- (1) This clause is specified by reference to the Specifications for Highway Bridges II 6.2 [Japan Road Association, 2002]. At the design stage, fillet welds must be of at least the required size to ensure that undesirable cracks do not occur. The weld size (shown as S in Fig.C11.5.9(a)) is not necessarily the length to the end of weld metal. In Fig.C11.5.9(b), size S is shown for a case where the shape of the weld is not an isosceles triangle.

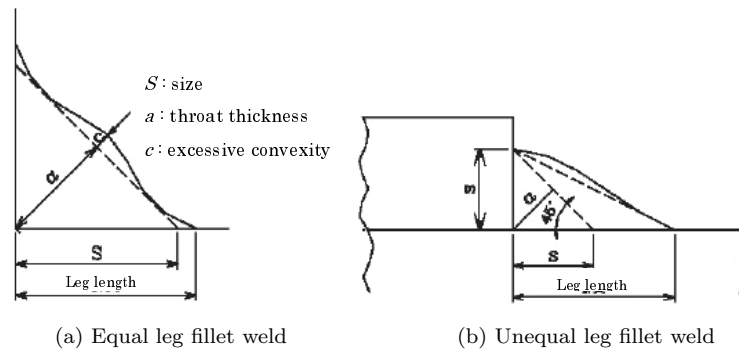

Fig.C11.5.9 Fillet weld size

The standard size of fillet weld, S , is that which satisfies Eq.(C11.5.4) and is also greater than 6mm. The upper limit of weld size as calculated by Eq.(C11.5.4) is 8mm. For welds of this size, appropriate preheating is necessary if steel with a P_{CM} (the weld cracking parameter) exceeding 0.24 is used or if covered arc welding is used.

$$t_1 > S \quad \text{and} \quad S \geq \sqrt{2t_2} \quad (\text{C11.5.4})$$

where , S : size(mm)
 t_1 : thickness of thinner plate(mm)
 t_2 : thickness of thicker plate(mm)

Oversized welds needlessly increase strain and broaden the area of material whose structure is changed by welding. On the other hand, welds that are too small tend to crack as a result of rapid cooling. This is the reason for these minimum and maximum values of standard weld size being specified. These standard values are the same as those in the Specifications for Steel Highway Bridges, 1956 as well as in the current specifications for highway bridges. In this code, the upper bound of fillet size up to 8mm is added. For instance, 10mm is the upper bound in the design standards for steel structures [Architectural Institute of Japan, 2004] as the standard for steel buildings, while 8mm is the upper bound in AASHTO, 1994 as the standard for steel bridges in the USA when the plate thickness exceeds 20mm. According to Minami, et al 2005, ① modern steel materials rarely crack as a result of rapid cooling even if $S \geq \sqrt{2t}$ is not satisfied, since P_{CM} is low and the content of diffusible hydrogen (that affects crack occurrence) is low in the case of submerged arc welding or shielding gas welding; ② the welding of extremely thick plate of small area raises the maximum value of Vickers hardness locally, though if the fillet size is 8mm, the defect might be removed; and ③ weld cracking might occur if steel with a P_{CM} exceeding 0.24 is welded using covered arc welding in which diffusible hydrogen is high. The value in this code is specified in consideration of these findings.

As a remarkable point in design, Until now, the shear strength requirement dictated fillet welds of 6mm or less for the web plate and flange plate of a girder bridge. A stress verification of fillet welding was sometimes omitted. However, it is now necessary for the fillet weld size to be verified for shear stress, if necessary, because the section details are different.

The minimum effective length of a fillet weld should be the length that can be properly welded without undesirable cracking. Cracking occurs easily due to quick cooling if the heat capacity of the weld is less than that of the surrounding material. In general, a weld should be at least 10 times the fillet size, or more than 80mm and more.

If welded connections are designed only by considering the forces applied, stress might concentrate locally even if the calculated overall stress of the connections is low. Since the stiffness of the welded connection will decrease significantly in this case, the connection might form the weak point of the structure with respect to secondary stress when the applied force is below the strength of the connected members. In such cases, careful consideration is necessary.

- (2) Structural details of the standard butt joint, lap joint, and T-joint, which are typical connection types used in steel and composite structures, are described in below:

1) Butt joint

Where a butt joint connects members with different cross sections along the principal direction, such as at main girder connections, the cross section should be adjusted appropriately so as to ensure the equal transfer welding heat and reduce stress concentrations as much as possible.

According to Specifications for Highway Bridges II 6.2.10 [Japan Road Association, 2002], there should be an inclination of $1/5$ or less in the length direction.

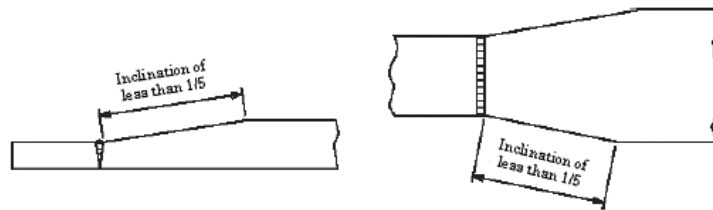

Fig.C11.5.10 Butt joint of primary members with different cross sections

2) Lap joint

- ① In the case of a lap joint that transfers load, undesirable stress concentration and secondary stress must be avoided.
- ② A front fillet weld or one/two sided fillet weld should be used because a bending moment acts on the bead and stress concentrations would readily occur if a single fillet weld were used.
- ③ A lap joint with a small lap deforms quite easily because it has less resistance to eccentric loading. The lapped amount should be five or more times the thickness of the thin plates, since rupture strength falls with secondary stress.
- ④ The specification in a case where a side fillet weld only is used for a lap joint subjected to axial force at the member end is given as follows:
 - Distance of weld line shall be less than 16 times of the thickness of the thinner plate in principle. However, if it is subjected to only tensile force, the value is 20 times. If this value is exceeded, special measures to prevent the plate lifting need to be implemented. This is achieved by specifying the maximum bolt spacing, the aim of which is to prevent local buckling or plate lifting and to smooth load transfer.
 - Length of side fillet weld should be greater than the distance between weld lines to

smooth load transfer.

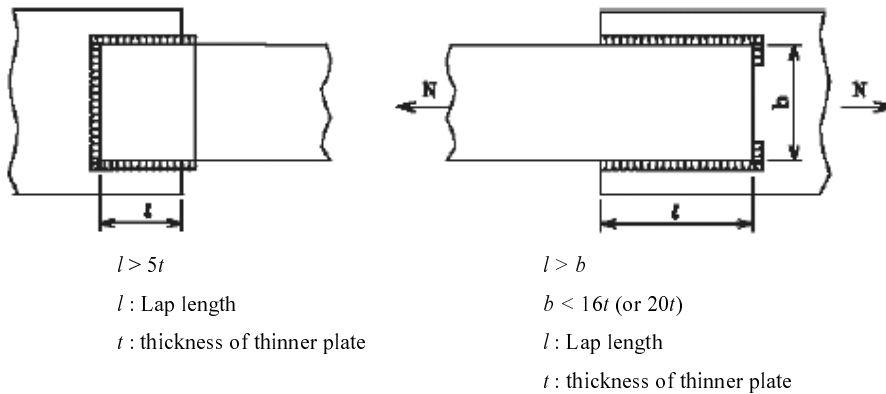

Fig.C11.5.11 Lap joint by fillet welding

3) T-joint

- ① In the case of a one-sided fillet weld or partial-penetration groove weld at a T-joint subjected to external force, the stress concentrates at the root of the weld, which is one of the weak points of a fillet weld, and resistance to deformation is low. Therefore, this type of weld may be used only if the connection has a structure that resists deformation in the horizontal direction, such as where sections of the chord member in a truss structure are joined. However, both sides of the T-joint must be welded in the case of a single T-joint. The standard of effective length of a fillet weld for primary members is more than ten times the fillet size.
- ② Where the angle of a T-joint is less than 60° , adequate fillet weld penetration at the root cannot be achieved. Further, where the angle of a T-joint is greater than 120° , the weld volume increases so as to satisfy the required throat size. In such cases, full-penetration groove welding should be used in principle.

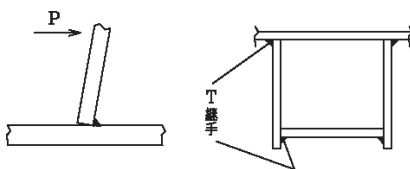

Fig.C11.5.12 T-joint

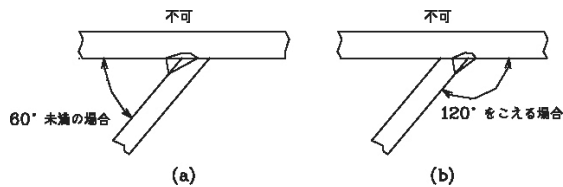

Fig.C11.5.13 T-joint with angle under 60° above 120°

11.6 High-Strength Bolted Connections

11.6.1 Requirements for safety of high-strength bolted connections

The requirements for the safety of high-strength bolted connections shall be specified such that the requirements given in 11.2 are satisfied.

【Commentary】

- (1) High-strength bolted connections fall into three categories according to their load-transfer mechanism: 1) friction type, 2) bearing type, and 3) T=tension type.

A friction-type bolted connection is one which transfers the load by the frictional force between

two plates tightened together with high-strength bolts. A bearing-type bolted connection is one which transfers the load by the bearing force between the bolt hole and the bolt shank, using the shear resistance of the bolt. This is the same load-transfer mechanism as in a riveted connection. The performance of a bearing-type connection can be improved by tightening the bolt. A tension-type bolted connection is one which transfers the load by reducing the contact stress between two plates tightened together with bolts. A short tension-type connection uses normal high-strength bolts while a long tension-type connection consists of long high-strength bolts or PC rods and rib plates.

- (2) Friction-type connections should be designed so as to be safe against slip at the connection and against yielding of the connected plates. Where a gap is found between the two plates, a filler plate must be fitted in principle, following clause 11.7.7 in order to avoid reduced slip resistance and corrosion. Bearing-type connections should be designed so as to be safe against shearing of the bolt shank and yielding of the bolt and the plates. In recent years, however, bearing-type bolted connections are generally used only as a means of strengthening members with fatigue cracks and there is little application of this connection type in road bridges. Further research and more application examples are needed before bearing-type bolted connections can be used more widely. This code specifies a draft bolt as the standard bolt for bearing-type bolted connections. There are many problems in using this type of connection, including constructability, plate defects caused by bolt installation, correction work after fabrication, drill design, and so on. Bearing-type bolted connections must be used only after considerable effort to understand the load-transfer mechanism, constructability, and suitability with regard to the surrounding environment.

Tension-type bolted connections should be designed so as to be safe against bolt failure and yielding of the connected plates. At the design stage, in particular, it should be noted that axial force, joint rigidity, and stress occurring at the connection are influenced greatly by joint details and by any strengthening of the connected portions. Since this type of connection makes use of the contact stress between two plates, as with the friction-type connection, bolt axial forces and flange plate flatness should be considered. Examples of the application of this type connection are connections of anchor frames, sole plates for shoes, corner connections in steel rigid-frame piers, and connections between main and lateral girders.

- (3) High-strength bolted connections should not be used for connections that might be submerged, in principal, because of the danger of reduced slip coefficient, bolt corrosion, and delayed fracture of the bolt. However, such connections might be used after confirming that submergence will not cause these conditions and that the safety of the joints is maintained. Further, special consideration of bolt corrosion is required for these connections whether or not they are submerged.
- (4) In any of these connections, the connection location, constructability, and the surface state of the connected members must be checked to ensure that the required performance of the connection is satisfied.

11.6.2 Safety verification of high-strength bolted connections

The safety of high-strength bolted connections shall be verified in accordance with 11.3.

【 Commentary 】

The safety of high-strength bolted connections should be verified with respect to load-carrying capacity and deformability in accordance with 11.3.

The verification of load-carrying capacity should basically confirm that it exceeds the corresponding force resulting from the action, taking into consideration the load-transfer mechanisms of friction-type,

bearing-type and tension-type bolted connections, respectively. However, the method of verification given below may be used under the presupposition of the structural details given in 11.7.

An example of the verification equations for load-carrying capacity using the partial factors specified in the Design Standard for Railway Structures is given here.

1) Verification of slip resistance of friction-type connections

- ① Verification for connections subjected to axial force/shear force should be carried out using the following equation.

$$\gamma_a \gamma_b \gamma_i \frac{P_s}{P_u} \leq 1.0 \quad (\text{C11.6.1})$$

- where , γ_a : structural analysis factor
 γ_b : structural member factor
 γ_i : importance factor
 P_s : applied force for bolts in row i
 P_u : slip resistance of bolts in row i ($P_u = nm \frac{P_a}{\gamma_m}$)
 n : number of bolts used for the shear plate
 m : number of friction surfaces
 P_a : characteristic value of slip resistance of bolt per slip surface
 (Table C11.6.2)
 γ_m : material factor

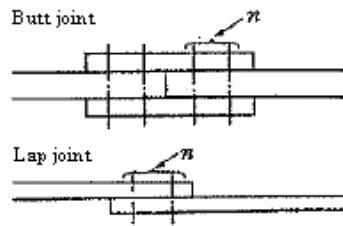

Fig.C11.6.1 Numer of bolt

- ② Verification for connections subjected to shear force/bending moment should be done using the following equations.

$$\gamma_a \gamma_b \gamma_i \frac{P_i}{P_u} \leq 1.0 \quad (\text{C11.6.2})$$

$$(\gamma_a \gamma_b \gamma_i)^2 \left\{ \left(\frac{P_i}{P_{ui}} \right)^2 + \left(\frac{V_s}{V_u} \right)^2 \right\} \leq 1.0 \quad (\text{C11.6.3})$$

- where , γ_a : structural analysis factor
 γ_b : structural member factor
 γ_i : structural factor
 P_i : applied force for bolts in row i (Fig.C11.6.2)
 P_{ui} : slip resistance of bolts in row i ($P_{ui} = n_i m \frac{P_a}{\gamma_m}$)
 n_i : number of bolts in row i (Fig.C11.6.2)
 m : number of friction surfaces

- P_a : characteristic value of slip resistance of bolt per slip surface (Table C11.6.2)
- V_s : shear force applied to the connection
- V_u : shear slip resistance ($V_u = nm \frac{P_a}{\gamma_m}$)
- n : number of bolts used for the shear plate
- γ_m : material factor

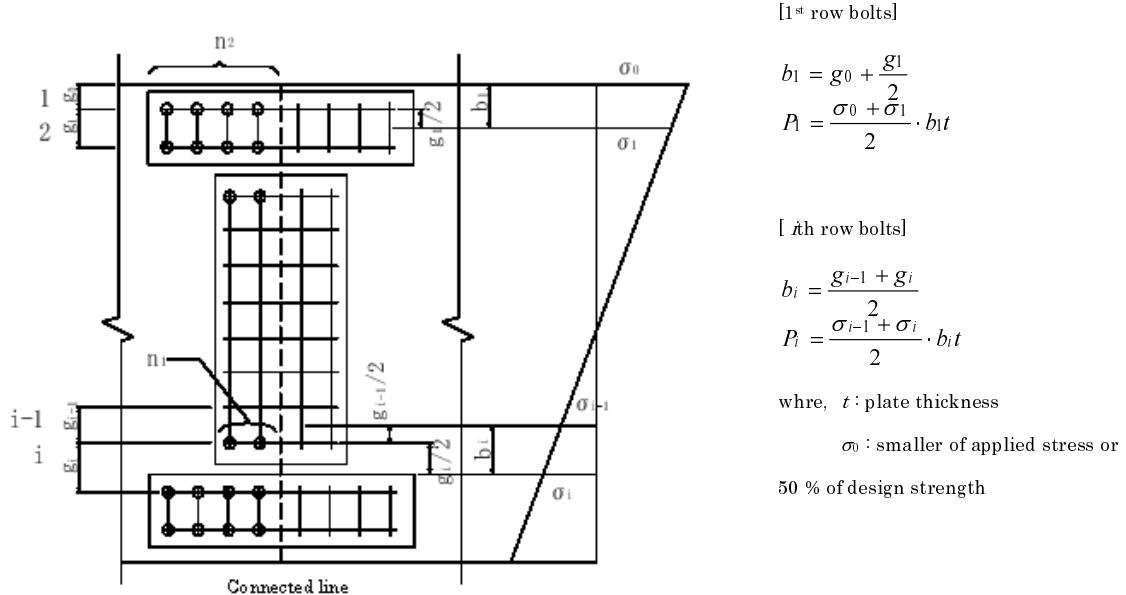

Fig.C11.6.2 Web joint (subjected to moment and shear)

③ Verification for horizontal joints of flanges/webs in the bridge axial direction should be carried out using the equation below.

This equation is good for the case of horizontal connections between web plates subjected to shear force with bending moment. However, in this case the effect of the torsional moment should be considered.

$$\gamma_a \gamma_b \gamma_i \frac{P_s}{P_u} \leq 1.0 \tag{C11.6.4}$$

- where , γ_a : structural analysis factor
- γ_b : structural member factor
- γ_i : structural factor
- P_s : force applied to the connection ($P_s = \frac{V_s Q}{I} p$)
- V_s : shear force applied to the connection
- Q : geometrical moment of the outside section from joint line
- I : moment of inertia of the girder
- p : pitch of bolts
- P_u : slip resistance of the joint ($P_u = nm \frac{P_a}{\gamma_m}$)
- n : number of bolts in the transverse direction of the joint line
- m : number of friction surfaces
- P_a : characteristic value of slip resistance of a bolt per slip surface (Table C11.6.2)
- γ_m : material factor

In the case of connections for a girder with a wide steel deck (as shown in Fig.C11.6.3(b)), this equation is used if the steel deck and flange are connected in the bridge axial direction.

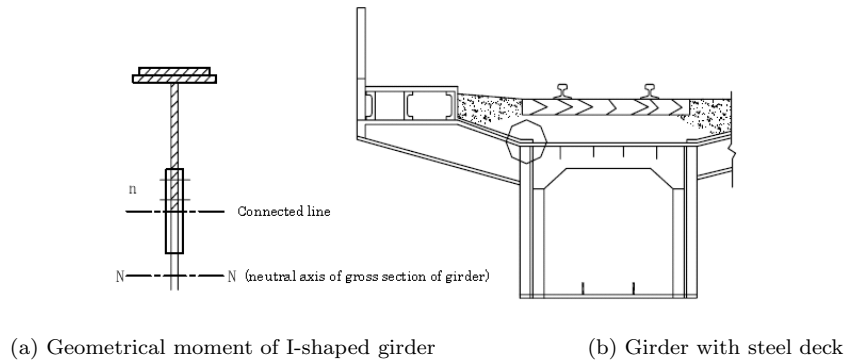

Figure.C11.6.3 Examples of joints in bridge axial direction

④ Verification by total slip resistance method for friction joints subjected to bending moment

In the design method shown in subsections ① and ②, connections between flanges and web plates are individually designed for bending moment. However, in the case of connections of I-shaped girders subjected to bending moment, for example, the flange and web together resist the bending moment. Therefore, in Recommendation on Design, Construction, and Maintenance of Friction-type High-strength Bolted Connections (draft) [Japanese society of civil engineers, 2006], consistency between the design method and actual behavior is ensured and the total slip resistance method is recommended. That verification method is described below. Still, here, the reduction in slip resistance due to such circumstances as the presence of a gap between the slip surfaces can be considered by using a correction factor, ϕ_1 .

In the verification for slip of all friction-type connections subjected to bending moment, it must be confirmed that the slip resistance (bending moment) is larger than the applied bending moment.

Considering the combined action of the flange and web plate by applying the total slip resistance method, the slip resistance (bending moment) M_{SL} is calculated as follows.

$$M_{SL} = \sum (\phi_3 \phi_1 \gamma_i \rho_{\ell i}) \quad (\text{C11.6.5})$$

$$\rho_{\ell i} = \rho_s \times m \times n \quad (\text{C11.6.6})$$

where , γ_i : distance to centroid of the position of the i line of bolts from the neutral axis (distance to the plate thickness center, in the case of a flange)

$\rho_{\ell i}$: slip resistance of bolts in row i

ρ_s : slip resistance of a bolt per slip surface (Table C11.6.2)

m : number of friction surfaces

n : number of bolts in each row

ϕ_1 : correction factor for slip resistance

ϕ_3 : correction factor for slip resistance (bending moment)

(for flange: 1.0; for web: 0.8)

2) Safety verification of bearing connections

The bearing resistance of butt joints or lap joints subjected to tension, compression, or shear force is verified on the basis of Eq.(C11.6.1).

The resistance of high-strength bolts used in bearing connections may be lower than the shear resistance or bearing resistance of the bolts as calculated based on their diameter. And the effective bearing area of a bolt is determined as the product of its nominal diameter and the thickness of the steel plates used. However, in calculating the effective bearing area of a flat-head bolt, half of the depth in the head may also be effective. (Fig.C11.6.4).

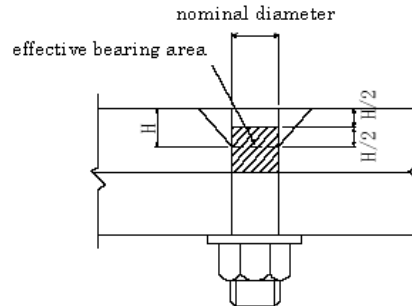

Fig.C11.6.4 Effective bearing area of flat-head bolt

$$\gamma_a \gamma_b \gamma_i \frac{P_s}{P_u} \leq 1.0 \quad (\text{C11.6.7})$$

- where , γ_a : structural analysis factor
 γ_b : structural member factor
 γ_i : structural factor
 P_s : force applied to the connection
 P_u : slip resistance of the joint ($P_u = n m \frac{P_a}{\gamma_m}$)
 n : number of bolts
 m : number of joint surfaces
 γ_m : material factor
 P_a : characteristic value of resistance of a bolt as follows:
the smaller of the shear resistance $P_{sa} = \tau_a A_s$ or
the bearing resistance $P_{ba} = \sigma_b A_b$
 τ_a : characteristic value of shear resistance of a bolt (Table C11.6.3)
 σ_b : characteristic value of bearing resistance of a bolt (Table C11.6.4)
 A_s : cross-sectional area of bolt shank
 A_b : effective bearing area of bolt shank (product of thickness of plate and bolt nominal diameter)

3) Safety verification of tension-type bolted connections

Tension-type bolted connections, which transfer the load in the bolt axial direction using the strength of the bolts, appear very useful. When using this type of joint, the resistance of the bolts, the tightening force, the rigidity of the connection, and the stress state must be sufficiently considered.

In some current standards, tension-type bolted connections are forbidden, in principle, for connections where there is fatigue action. The safety verification method for tension-type bolted connections and the application examples shown in Fig.C11.6.5 are taken from Specifications for Highway Bridges [Japan Road Association, 2002] and Design Standard for Railway Structures (Composite Structures of Steel and Concrete) [Railway Technical Research Institute, 2002]. Additionally, Recommendation for Design of High-Strength Tensile Bolted Connections for Steel Bridges [Japanese Society of Steel Construction, 2004] can be referred to as the latest design

standard for bridge structures.

The safety verification of tension-type bolted connections using the partial factor method is described below.

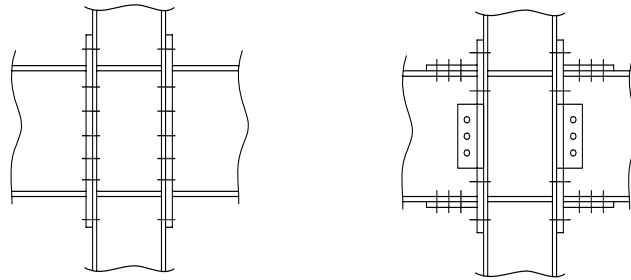

Fig.C11.6.5 Examples of tension-type connections

- ① Verification of tensile-type connections subjected to tensile force should be carried out using the following equation.

$$\gamma_a \gamma_b \gamma_i \frac{P_t + R_t}{P_u} \leq 1.0 \quad (\text{C11.6.8})$$

- where , γ_a : structural analysis factor
 γ_b : structural member factor
 γ_i : structural factor
 P_t : tensile force applied to the connection
 R_t : prying force caused by bending of T-flange, which is calculated considering the thickness of the T-flange, the arrangement of bolts, and the dimensions of each part of connection
 P_u : resistance of the connection ($P_u = n \frac{P_{ta}}{\gamma_m}$)
 n : material factor
 P_{ta} : characteristic value of resistance of bolt (Table C11.6.5)
 γ_m : material factor

However, in case of a long connection, the prying force can be ignored, because the rib plates reduce the local deformation of the connection and the contact stress is concentrated in the center of the connected member.

- ② Verification for shear force of tensile-type connections subjected to tensile force and shear force simultaneously should be carried out using the following equation.

$$\gamma_a \gamma_b \gamma_i \frac{V}{V_u} \leq 1.0 \quad (\text{C11.6.9})$$

- where , γ_a : structural analysis factor
 γ_b : structural member factor
 γ_i : structural factor
 V : shear force applied to the connection
 V_u : shear resistance of the connection
 $(V_u = \frac{nP_a}{\gamma_m} \left\{ \frac{nP_n - P_t}{nP_a} \right\})$
 n : number of bolts

- P_a : characteristic value of slip resistance of a bolt per slip surface
 (Table C11.6.2)
 P_n : pre-tension force introduced to bolt
 P_t : tensile force applied to the connection
 γ_m : material factor

4) Verification at yield state of friction-type connections and bearing-type connections

Connected plates and splices where friction-type connections and bearing-type connections are used can be verified at the yield state using the following equation.

$$\gamma_a \gamma_b \gamma_i \frac{P_s}{P_u} \leq 1.0 \quad (\text{C11.6.10})$$

- where , γ_a : structural analysis factor
 γ_b : structural member factor
 γ_i : structural factor
 P_s : force applied to the connected plates/splice
 P_u : yield strength of the connected plates/splice

In Japan Society of Civil Engineers, 2006, the yield strength of connected plates and splices is recommended to be calculated differently according to whether tensile force or compressive force is acting. In particular, when tensile force acts on the connection, friction is assumed to transmit part of the applied force through use of a yield resistance correction factor.

The following are the methods recommended in Japan Society of [Civil Engineers, 2006].

(i) Yield strength of friction-type connections subjected to tensile force P_{ty}

$$P_{ty} = \phi_2 P_{yn} \quad (\text{C11.6.11})$$

where , P_{yn} : the smaller of the yield strength of the connected plates or spliced components based on net sectional area.

ϕ_2 : correction factor for yield strength ($\phi_2 = 1.1$)

Yield strength P_{ty} should be smaller than the yield strength of the gross section.

(ii) Yield strength of friction-type connections subjected to compression force P_{cy}

$$P_{cy} = \phi_2 P_{yg} \quad (\text{C11.6.12})$$

where , P_{yg} : the smaller of the yield strength of the connected plates or spliced components based on gross sectional area.

ϕ_2 : correction factor for yield strength ($\phi_2 = 1.0$)

11.6.3 Design characteristic values for verification of connection safety

Design characteristic values for the verification of connection safety shall be specified appropriately in consideration of the load-transfer mechanism and the verification method used.

【 Commentary 】

Design characteristic values may be specified as follows based on past experience and examples. However, the design characteristic values as follows shall be specified the requirements given in Table C11.6.4.

(1) Design characteristic values for the slip resistance of friction-type bolted connections

The design characteristic values for the slip resistance of a bolt per slip surface, P_a , are obtained

using the following equations.

$$P_a = \mu N \quad (\text{C11.6.13})$$

$$N = \alpha \sigma_y A_{be} \quad (\text{C11.6.14})$$

where , μ : slip coefficient
 N : design axial force on bolt
 σ_y : yield strength of bolt specified in JIS B 1186
 α : ratio of yield strength
 A_{be} : effective cross-sectional area of bolt specified in JIS B 1186

The slip coefficient and design axial force are important in calculating the slip resistance. The slip coefficient, μ , is specified as a uniform value of 0.40 in [Japan Road Association, 2002] as well as in the Design Specifications for Railway Structures and Commentary (Steel/Composite Structures) [Railway Technical Research Institute, 2000]. In [Japan Society of Civil Engineers, 2006], the recommended value of slip coefficient depends on conditions at the joint surfaces, as shown in Table 11.6.1. This is based on design specifications in other countries and in the field of architecture, as well as past experience. Thus, slip coefficient may be decided according to conditions at the joint surface. This guideline (draft) gives the standard testing method for obtaining the slip coefficient.

Table C11.6.1 Recommended slip coefficients for various conditions at the joint surface

Conditions at joint surface	Slip coefficient μ	Comments
Ideally rusted surface	0.55	Unpainted clean mill scale with ideal amount of rust
Ideally rusted surface obtained with chemicals	0.45	Ideal amount of rust obtained using chemicals
Rough surfaces	0.25	Rough rust-free surface formed with disk grinder
	0.35(indefinite roughness)	Rust-free blast-cleaned surface obtained by shot/grit blasting
	0.40($10\mu\text{m} > R_a \geq 5\mu\text{m}$)	
	0.45($R_a \geq 10\mu\text{m}$)	
Inorganic zinc-rich paint	0.40(paint thickness $\leq 65\mu\text{m}$)	Standard of paint thickness must be $150\mu\text{m}$
	0.50(paint thickness $\geq 65\mu\text{m}$)	Content of dry zinc in paint must be more than 80%
Organic zinc-rich paint Hot-dip galvanized	Decide after confirming the performance of connections by conducting slip test	* Shown as "tentative slip coefficient" in the guidelines on Design Standards for Steel Structures (Steel Bridges) [Japanese Society of Steel Construction, 2004]
Metallic spray		
Surface roughened by mechanical processing		

Standards for ratio α of yield strength σ_y in Eq.(C11.6.14) are 0.85 and 0.75, for F8T and for F10T bolts, respectively, in [Japan Road Association, 2002], and [Railway Technical Research Institute, 2000]. The slip resistance of a bolt per slip surface, P_a , in the case that the slip coefficient μ is 0.40 is given in Table 11.6.2.

Table C11.6.2 Slip resistance of a bolt per slip surface, P_a (kN)

Grade of high-strength bolt	Nominal diameter	α	σ_y (N/mm ²)	A_{be} (mm ²)	N (N)	P_a * $\mu = 0.4$
F8T	M16	0.85	640	157	85,410	34
	M20			245	133,280	53
	M22			303	164,840	66
	M24			353	192,040	77
F10T S10T	M16	0.75	900	157	105,980	42
	M20			245	165,380	66
	M22			303	204,800	82
	M24			353	238,280	95

It is known that the slip resistance depends on the clearance and shape of the bolt holes as well as on the number of bolt rows. The recommendations of JSCE [Japan Society of Civil Engineers, 2006], proposes that the slip resistance be corrected according to the following:

- Clearance
- Filler plates
- Oversized bolt hole
- Multiple arrangement of high-strength bolts
- Slip/yield resistance ratio (β)

Moreover, [Railway Technical Research Institute, 2000], gives an equation for reducing the slip resistance for parts subjected to tensile force. It also requires that care is taken with respect to local buckling of the plates.

- (2) Characteristic values of shear strength and bearing strength for high-strength bolted connections of bearing type

The characteristic values of bolt shear strength and bearing strength of the connected plates are specified as follows in [Railway Technical Research Institute, 2000].

In the commentary accompanying the design standard for buildings published in 1983, the shear strength of a high-strength bolt is specified as $1/\sqrt{3}$ times its tensile strength, as for allowable stress, and the safety factor is calculated as 1.6 against the lower limit of yield resistance σ_y and 3.0 against the lower limit of yield tensile strength σ_B . In [Railway Technical Research Institute, 2000], the resistance is specified as 1.6 times the allowable stress mentioned above. The Specifications for Highway Bridges and Commentary (II Steel Bridges) [Japan Road Association, 2002] is based on same concept except that the safety factor against yield strength is 1.7 for allowable shear strength. The characteristic value of shear strength of high-strength bolts for bearing-type connections is summarized in Table C11.6.3.

The characteristic value of bearing strength should be 1.5 times the standard yield strength as well as structural steel as shown in Table C11.6.4. However when this value is greater than the tensile strength, the tensile strength should be taken as the upper limit.

Table C11.6.3 Characteristic values of shear strength of high-strength bolts for bearing-type connections, τ_u (N/mm²)

Grade of high-strength bolt	Yield stress or ultimate stress σ_y	Tensile strength σ_B	$\frac{1}{1.6} \frac{\sigma_y}{\sqrt{3}}$	$\frac{1}{3} \frac{\sigma_B}{\sqrt{3}}$	$\tau_u = \frac{1}{3} \frac{\sigma_B}{\sqrt{3}} \times 1.6$
B6T	480	600	173	116	185
B8T	640	800	231	154	245
B10T	900	1,000	325	192	305*reference value

*Reference value is based on [Railway Technical Research Institute, 2000]

Table C11.6.4 Characteristic values of bearing strength of high-strength bolts for bearing-type connections, τ_b (N/mm²)

Material	SS400 SM400 SMA400	SM490	SM490Y SM520 SMA490	SM570 SMA570
Bearing strength	360	480	520	570

- (3) Characteristic values of tensile yield strength of high-strength bolts for tension-type connections

The characteristic value of tensile yield strength of high-strength bolts for tension-type connections is specified as follows in [Japanese Society of Steel Construction, 2004], and [Railway Technical Research Institute, 2000].

$$B_y = \sigma_y A_{be} \quad (\text{C11.6.15})$$

Table C11.6.5 Characteristic value of tensile yield strength of high-strength bolts for tension-type connections, B_y (kN)

Grade of high-strength bolt	Nominal diameter	A_{be} (mm ²)	σ_y (N/mm ²)	B_y (kN)
F10T	M16	157	900	141
	M20	245		221
	M22	303		273
	M24	353		318
S10T	M20	245	900	221
	M22	303		273
	M24	353		318

- (4) Characteristic values of strength of normal bolts

The allowable stress for normal bolts as specified in JIS B 1051 is given as follows in [Japan Road Association, 2002]. The strength of a grade 4.6 bolt is assumed to have strength characteristics equal to those of an SS400 finish bolt. For grade 8.8 and grade 10.8 bolts, the safety factor for standard yield strength is set high, the allowable shear strength is specified as $1/\sqrt{3}$ times the tensile strength, and the allowable bearing strength is specified as 1.5 times the tensile strength, because the yield ratio (σ_y/σ_B) is high. [Railway Technical Research Institute, 2000], also specifies the strength of normal bolts similarly.

The characteristic values of strength of normal bolts are summarized in Table C11.6.6.

Table C11.6.6 Characteristic values of strength of normal bolts (N/mm²)

Grade as classified by JIS B 1051	Yield point or ultimate stress σ_y (N/mm ²)	Tensile strength σ_B (N/mm ²)	Shear strength $\sigma_y/\sqrt{3}$	Bearing strength $\sigma_y \times 1.5$
4.6	240	400	140	360
8.8	660	830	(380)	(990)
10.9	940	1,040	(540)	(1,410)

* strength values in () are based on [Railway Technical Research Institute, 2000].

- (5) Characteristic values of strength of pin and anchor bolts in concrete

The allowable stress of pins, as summarized in Table C11.6.7, is determined as 1.6 times the allowable stress, which is the value specified in the Design Standard and Commentary for Structures published in Japanese National Railways age, 1983, taking into consideration the convenience of the design given in [Railway Technical Research Institute, 2000]. Moreover, the characteristic value of shear strength of an anchor bolt in concrete should be taken as 70% of the shear strength of the pin, considering uncertainties in construction.

The allowable stress of pins and anchor bolts in concrete is determined by the same approach in [Japan Road Association, 2002].

Table C11.6.7 Characteristic values of strength of pins and anchor bolts (N/mm²)

Type of strength value		SS400	S30CN	S35CN	S45CN
Pin	Shear strength	170 (160)	190 ()	225 (225)	(240)
	Bending strength	320 (305)	370 ()	420 (420)	(465)
	Bearing strength	170 (170)	200 ()	225 (225)	(250)
Anchor bolt	Shear strength	120 (110)	135 ()	155 (155)	(155)

* Upper and lower values in () are those calculated by [Railway Technical Research Institute, 2000], and [Japan Road Association, 2002], respectively.

11.7 Structural Details of High-Strength Bolted Connections

11.7.1 Bolts, nuts, and washers

(1) Friction-type connections

Properties of bolt, nut, and washer materials used for friction-type connections shall comply with those specified in JIS B 1186 (Japanese Industrial Standards). Further, bolts, nuts, and washers shall have sufficient resistance to delayed fracture. Appropriate axial force shall be applied at installation and the force shall not decrease significantly during the service life.

(2) Bearing-type connections

Standards for bolts, nuts, and washers used for bearing-type connections shall be as specified in JSS II 01-1981 (Japanese Society of Steel Construction Standards).

(3) Tension-type connections

Properties of the bolt material used for tension-type connections shall comply with those specified in JIS B 1186 (Japanese Industrial Standards). Further, bolts shall have sufficient resistance to delayed fracture. The appropriate axial force shall be applied at installation and the force shall not decrease significantly during the service life.

【 Commentary 】

- (1) The delayed-fracture characteristics should be considered as well as the mechanical characteristics specified in JIS B 1186. In particular, attention should be paid to tightening the bolts by the yield strength tightening method, in which bolt axial force exceeds the yield strength.

Refer to article 6.3.2 of Specifications for Highway Bridges o Commentary [Japan Road Association, 2002] for the chemical properties of bolts in consideration of their delayed-fracture characteristics. Further, the standard torque coefficient for bolt sets should conform to Table C11.7.1.

In [Japan Road Association, 2002], and [Railway Technical Research Institute, 2000], the standard bolts used for friction-type connections are M16, M20, M22, and M24 in the first and the second category as given in JIS B 1186. In these specifications, the standard torshear bolts used for friction-type connections are the same as in JSS II09-1996. Other bolts, i.e. hot-dip galvanized bolts, rust-proof bolts, weathering steel bolts, fire-proof bolts, ultra high strength bolts, stainless steel bolts, or large-diameter bolts, can be used after confirming that article (1) is satisfied.

Large diameter bolts over M24 can be used with reference to [Japanese society of civil engineers, 2006].

- (2) High-strength bolts for friction-type connections and injection bolts may be used for bearing-type

connections. Because there is a clearance between the bolt hole and the bolt axis, the connection may slip before bearing. For this reason, injection bolts should be used in principle, because it is considered that such deformation is not desirable.

- (3) Tension-type connections transfer the load through the contact force obtained by introducing a high axial force into high-strength bolts as in friction-type connections. The requirements for high-strength bolts used in tension-type connections are basically the same as those for friction-type connections.

[Steel Construction of Japan, 2004], specifies standard high-strength bolts for tension-type connections in consideration of actual usage as follows.

The standard high-strength bolt for short connection types should be a high-strength bolt for friction-type connections. However, since this type of connection is required to operate very effectively, high-strength bolts of the first category (as given in JIS B 1186) should not be used. When torshear-type high-strength bolts are used for short connection types, a washer should be used under the bolt head in principle.

Steel rod with material properties equivalent to those of standard high-strength bolts can be used in place of high-strength bolts for long connection types, since standard high-strength bolts cannot be expected to be available in these lengths. When threads are cut at the ends of a carbon alloy steel rod for use in a long connection, the strength grade of the rod is less than 10.9 taking account of delayed fracture/fatigue. The shape of the threads must also be considered. When the same examination is carried out, design guidelines 3.2 or 3.4 of [Steel Construction of Japan, 2004] could be referenced.

Table C11.7.1 Torque coefficients for set of high-strength bolts

Average torque coefficient in shipment of one lot	0.110~0.160
Coefficient of variance of torque coefficient in shipment of one lot.	Less than 5%
Variation by temperature in shipment of one lot	Less than 5% of average of torque coefficient in shipment for a temperature change of 20

11.7.2 Holes for bolts

The size of holes for bolts shall be determined in consideration of the corresponding load-transfer mechanism for the connection type as well as workability.

【 Commentary 】

- (1) In friction-type and tension-type connections, the size of the bolt holes must be determined such that the required bolt axial force is secured, because these connections transfer the load through the contact force resulting from the introduced bolt axial force. The standard size of bolt holes for friction/tension-type connections is the value obtained by adding 2.5mm to the nominal diameter of the bolt. It is necessary to consider that slip resistance will decrease if the hole is oversized or if an elongated hole is used for reasons of workability. The maximum allowable hole sizes and their influences on slip resistance can be found in [Japanese society of civil engineers, 2006].

The design size of the hole is the value obtained by subtracting 3mm from the nominal diameter for the net sectional area of a friction-type connection. However, where the nominal diameter is 16mm, 2mm should be subtracted from the nominal diameter.

- (2) Regarding bearing-type connections, it is desirable that there is no clearance between the bolt

shank and the bolt hole, because load is transferred by the shear resistance of the shank and the bearing between the shank and the wall of the bolt hole. The standard size of the bolt hole for bearing-type connections is the value obtained by adding 1.5mm to the nominal diameter.

11.7.3 Bolt length

- (1) Bolts must be long enough to deliver firm contact force between the contact surfaces.
- (2) Bolt threads in bearing connections shall not extend into the shear plane.

【Commentary】

For bolt lengths, refer to the design data book [Japanese Association of Bridge Construction, 2006], or similar sources.

- (1) The following requirements should be satisfied in order to ensure secure tightening of bolts.
 - 1) Bolt threads should be visible at the plane of the nut end after tightening.
 - 2) There should be no incomplete thread turns within the nut after tightening.
- (2) The bolt length for bearing-type connections must satisfy the requirements given in this clause.

11.7.4 Bolt spacing

The minimum bolt spacing shall be larger than the spacing required to allow tightening. The maximum spacing should not exceed the local buckling and corrosion-prevention requirements.

【Commentary】

- (1) If the bolt spacing is too small, the work of tightening the bolts becomes impossible or the plates being connected might be damaged by tightening. On the other hand, if the bolt spacing is too large, corrosion/local buckling might occur due to the reduced plate contact. Therefore, the spacing must be carefully considered.
- (2) The minimum bolt spacing should follow the standard given in Table C11.7.2 considering the workability of bolt tightening and past experience. However, it might be possible to reduce the spacing to 3 times the bolt diameter. The minimum bolt spacing in Eurocode [CEN, 1993], Building Standards of Construction and Water Gate Steel Pipe Technical Standard [Water Gate Steel Pipe Association 2001] is 2.5 times the bolt diameter as the lower limit.

Table C11.7.2 Minimum bolt spacing (mm)

Nominal diameter of bolt	Minimum spacing (mm)
M30	105
M27	95
M24	85
M22	75
M20	65
M16	55

Note) The minimum spacing for M27 and M30 bolts is determined by referring to the Design Standard for Superstructure [Honshu-Shikoku Bridge Authority, 1995]

- (3) The maximum bolt spacing in the grid arrangement should, as standard, be the smaller value given in Table C11.7.3 in consideration of local buckling between bolts, contact between connected plates, and practical experience. The maximum bolt spacing in the struggle arrangement can be twice that in the grid arrangement in consideration of the fixing effect of the bolt which is located at the bolt line.
- (4) The maximum bolt spacing for matching of tension members should, as standard, be a value that

Table C11.7.3 Maximum bolt spacing (mm)

Nominal bolt diameter	Maximum bolt spacing		
	p		g
M30	210	$12t$ $12t$ 以下 $15t - 3/8g$ and under $12t$ (struggle arrangement)	$24t$ and under 300
M27	190		
M24	170		
M22	150		
M20	130		
M16	110		

Where, t : plate thickness of outside plate or shaped steel (mm)

p : bolt spacing along the stress direction (mm)

g : bolt spacing perpendicular to stress direction (mm)

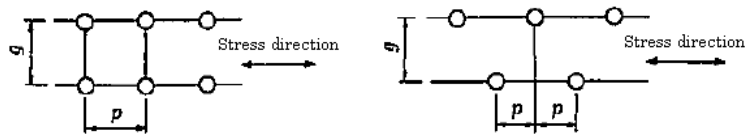
**Fig.C11.7.1**

does not exceed 300mm following the specification for the direction perpendicular to the stress.

11.7.5 End and edge distance

The minimum distance from the end or edge of a member to the centre of a bolt hole shall be larger than the value required to ensure that there is no end or edge failure because of tearing prior to bolt failure. The maximum distance from the end or edge of a member to the centre of a bolt hole shall not exceed the corrosion prevention requirements.

【Commentary】

- (1) The distance between the centre of a bolt hole and the edge/end of the plate must be specified such that the plate does not fail at the edge/end. If this distance is too short, failure of the plate might occur at the edge/end; on the other hand, if this distance is too great, contact between connected plates is not good and corrosion might occur because of water seepage. Both of these factors should be taken into account in determining the appropriate distance.
- (2) Standard minimum and maximum distances from the end or edge of a member to the centre of a bolt hole are given in Table C11.7.4. These values have previously been used in the design of riveted connections to prevent failure at the end or edge of the plates. In this code, the same values are also adopted as the minimum distance for a bolt considering past practice.

Since, with improved cutting technology, the quality of automatically gas-cut edges is almost equal to that of rolled edges and finished edges, there is no fear of detrimental effects of internal stress or hardening. The distance for automatically gas-cut edges should be the same as for rolled edges or finished edges. In the case of laser cutting, which is now a normal cutting method, the roughness of the edge is equivalent to that of an automatic gas-cut edge. However hardening of the material is greater than that of an automatic gas-cut edge, the area of the heat affected zone is smaller, and fatigue strength does not decrease. Considering these results and past practice, laser-cut edges are considered equivalent to rolled edges or finished edges.

- (3) The minimum distance from the end or edge in the stress direction as given by Table C11.7.4 might be insufficient when the number of bolts in this direction is less than 2, because the joint strength is greater for a bearing-type connection than a friction-type connection. The

Table C11.7.4 Minimum or maximum distances from the end or edge of a member to the centre of a bolt hole (mm)

Nominal bolt diameter	Minimum distance from end or edge (mm)		Maximum distance from end or edge
	Sheared edge, Hand-controlled gas-cut-edge	Rolled edge, finished edge, automatic gas-cut edge, laser-cut edge	
M30	–	55	8t and under 150
M27	–	50	
M24	42	37	
M22	37	32	
M20	32	28	
M16	28	23	

Note: M30, M27 is based on superstructure design standard [Honshu-Shikoku Bridge Authority, 1995]

Specifications for Highway Bridges [Japan Road Association, 2002] adds a verification using expression C11.7.1.

$$\left. \begin{array}{l} \text{Single shear} \quad e > a \frac{A}{t} \\ \text{Double shear} \quad e > a \frac{2A}{t} \end{array} \right\} \quad (\text{C11.7.1})$$

where , e : minimum distance from the end or edge in the stress direction (cm)

a : shear strength ratio of bolt and plates

A : nominal cross-sectional area calculated from the outside diameter of the thread (cm²)

t : thickness of thinner plates in single shear (cm)

: thinner value of thickness of connected plates or total thickness of splice plates in double shear (cm)

- (4) The maximum distance from the end or edge to the center of a bolt hole where the connected plates are lapped should be 8 times the thickness of the outside plates. But this value must not exceed 150mm.

11.7.6 Minimum number of bolts

At least two bolts are required per connection. Where a connection is subject to shear force, two rows of bolts, meaning a minimum of 4 bolts in total, are required.

【Commentary】

- (1) The minimum number of bolts is two, considering the possibility of insufficient contact between members and also the work of making the connection. The number of bolts per connection is shown in Fig.C11.7.2(a).
- (2) In the case of a connection subjected to shear force, two rows and two lines of bolts are required as shown in Fig.C11.7.2(b) in order to prevent rotation of the joint.

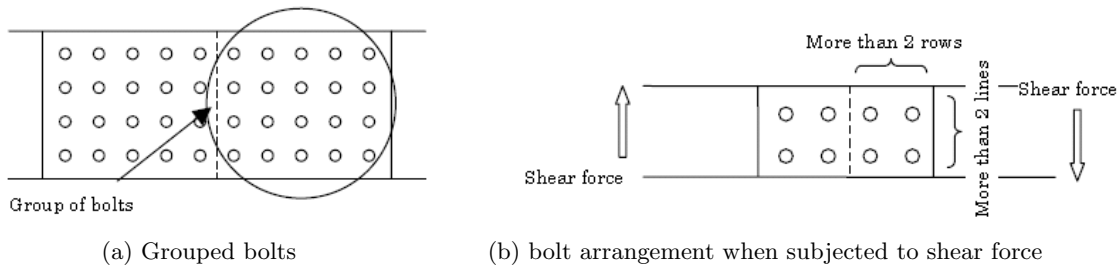

Fig.C11.7.2 Minimum number of high-strength bolts

11.7.7 Filler plates

- (1) In the case of friction connections where plates of different thicknesses are connected, filler plates should be installed to fill the design gap.
- (2) Where it is impossible to install a filler plate, the slip resistance of the connection shall be reduced by means of an appropriate method.
- (3) In choosing the thickness and material grade of the filler plate, corrosion prevention and protection from rust shall be considered in addition to the load-transfer mechanism.

【 Commentary 】

- (1) Required performance cannot be secured with friction-type connections if there is a gap between the connected plates, since local concentrations of contact force might arise or corrosion might occur if rain enters between the plates. Therefore, if there is a difference between the design thicknesses of the connected plates, a filler plate shall be installed to fill the gap. The limitation on the thickness of this filler plate is half the thickness of the thicker connected plate.
- (2) If a plate with adequate thickness is not available as a filler plate, the resulting reduction in slip resistance must be estimated by an appropriate method. The effect of a gap on slip resistance is summarized in [Japan Society of Civil Engineers, 2006].
- (3) It has been confirmed through slip tests on general structural rolled steel plates that friction-type connections with filler plates have adequate slip resistance regardless of the grade of material used for the filler plates. This means that any general structural steel plate is suitable for use as a filler plate. However, if the connected plates are of weather-proof steel, the same material should be used for a filler plate from the viewpoint of corrosion prevention and protection from rust.

11.7.8 Angled and round washers

In a case where the bolt axis is not perpendicular to the surface of the connected member, or if the surface of the connected member is not flat, care shall be taken not to impose undesirable bending stress on bolts and washers.

【 Commentary 】

Since the flanges of steel with an I-section or channel section are not necessarily parallel and the bolt axis may not be perpendicular to the member surface, bending stress can occur at the bolt. Similarly, if the surface at the joint is curved, a bending moment will be applied to the washer on the inside of the curve and cracks may occur. Therefore, care should be taken that harmful stress does not occur in bolts and washers in such cases. In Specifications for Highway Bridges II section 6.3.14 [Japan load association, 2002], it is noted that 1) if the angle between the bolt head or nut surface and the member surface is more than $1/20$, an angled filler or washer should be installed so as to prevent eccentric

stress arising and 2) if the joints are curved and the radius of curvature is small, round washers should be used.

Concerning friction-type connections for longitudinal profile (LP) steel plates, it is reported in [Kamei, et al., 2000], that adhesion between connected plate and splice plate surfaces can be assured by tightening the high-strength bolts; in this case bending deformation of the splice plates and the bolts does not significantly affect the behavior of the connection for taper angles up to 4.8/1000. These results were obtained in tensile tests for various dimensions of connection. This means that tapered joints can be used without the need for sections of equal thickness or shaped splice plates.

According to [Japan Road Association, 2002], special attention should be paid to curved connections where the diameter of curvature is less than about 1.0m.

11.8 Bolted Connections

11.8.1 General

- (1) Regular bolted connections shall be adopted in cases where there is no need for high-strength bolted connections.
- (2) The standard use of bolted connections is for bearing-type or tension-type connections where there is no axial force on the bolt.

【Commentary】

- (1) In the Design Standards for Railway Structures and Commentary (Steel and Composite Structures) [Railway Technical Research Institute, 2000], regular bolts up to M10 are allowed for use in connections for the attachment of bearing supports, inspection walkways, tension panels, drainage equipment, etc. That is, these connections in these cases do not require high-strength bolts. But regular bolts should not be used for connections subjected to cyclic force.
- (2) A regular bolted joint is a connection that uses regular bolts. It is different from a high-strength bolted joint in which contact force arises from the bolt axial force. Therefore, regular bolted joints should be used only for bearing-type and tension-type connections. Regular bolts must not be used for friction-type and tension-type connections that rely on bolt axial force.
- (3) Stainless steel bolts for corrosion protection, post-construction hitting or resin anchor bolts, U-bolts, and I-bolts, etc. may be used if this clause is followed.
- (4) If there is a possibility that bolts might loosen, protection should be provided by using locking nuts or similar.

11.8.2 Bolts, nuts, and washers

The standard bolts, nuts, and washers used in bolted connections shall be as specified in JIS B1180, JIS B1181, and JIS B1256, respectively.

【Commentary】

[Railway Technical Research Institute, 2000], specifies using the following types of regular bolts for the attachment of bearing supports, inspection walkways, tension panels, drainage equipment, etc.:

- 1) The standard finish is the middle grade and standard precision threads are the second grade.
- 2) Bolts should be galvanized in a bath in principle; bolt diameter should be greater than 12mm.
- 3) Locking nut should be used where there is possibility of loosening due to vibration, etc.

11.8.3 Structural details

Structural details of bolted connections should be determined appropriately in the same way as those of high-strength bolted connections.

【Commentary】

- (1) The diameter of holes for regular bolts in tension-type connections should be as given in JIS B 1001. The standard diameter of holes for regular bolts in bearing-type connections shall be added a nominal diameter of bolts to 0.5 mm.
- (2) The minimum and maximum spacing of regular bolts with nominal diameter greater than M16 may be the same as for high-strength bolted connections. The standard minimum and maximum spacing in regular bolted connections with M10 and M12 bolts may be as shown in Table C11.8.1, which was derived from Design Specifications for Railway Structures and Commentary (Steel and Composite Structures) [Railway Technical Research Institute, 2000]. But if the thickness of the tension panels or steel floor plates is less than 4.5mm, the maximum spacing should be less than 110mm in consideration of ensuring contact.

Table C11.8.1 Minimum and maximum spacing for regular M12 and M10 bolts (mm)

Nominal bolt diameter	Minimum distance	Maximum distance
M12	40	Max 150~under 110
M10	30	

- (3) The distance from the edge/end of the plate to the center of a bolt hole for regular bolts greater than M16 may be as given in the clause specifying high-strength bolts. The standard distance from the edge/end to the center of a bolt hole for regular M10 and M12 bolts may be as shown in Table C11.8.2, which was derived from Design Specifications for Railway Structures and Commentary (Steel and Composite Structures) [Railway Technical Research Institute, 2000]. However, the maximum distance should be determined in consideration of ensuring plate contact and should be in agreement with the maximum spacing.

Table C11.8.2 Minimum and maximum distance from edge/end to center of a bolt hole (mm)

Nominal bolt diameter	Minimum distance from end or edge		Maximum distance from end or edge
	Sheared edge, Hand-controlled gas-cut-edge	Rolled edge, finished edge, automatic gas-cut edge, laser-cut edge	
M12	22	19	8t and under 150
M10	20	17	

- (4) The minimum number of bolts is two.
- (5) Structural details for angled and round washers may be as given in the clause specifying high-strength bolted connections.

11.9 Pin Connections

- (1) Structural members joined by pin connections shall not move at the point of connection. Further, nuts should be secured to prevent pins coming loose. The influence of wear on rotation at the pin and pin-hole shall be minimized.
- (2) Pin design shall include consideration of wear loss to the pin cross section.
- (3) In designing a member with a hole for a pin, the safety of the connection shall be verified in consideration of the stress concentration adjacent to the hole.

【Commentary】

- (1) Movement between structural members that are joined by pin connections has a bad influence on the vibration and impact of girders and can lead to concerns about the occurrence of secondary stress and joint galling. Accordingly, any movement should be restrained using collars or rings, etc. An example of a pin connection is shown in Fig.C11.9.1.

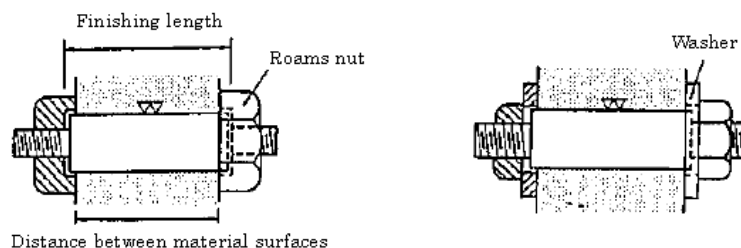

Fig.C11.9.1 Pin and nut

- (2) The Specifications for Highway Bridges specify the structural details of pin connections in section 6.4 Pin Connections [Japan Road Association, 2002] as follows:
 - 1) The diameter of the pin must be greater than 75mm.
 - 2) The length of the finished part of the pin should be greater than 6mm. The ends of the pin should be fitted with a Roams nut or regular bolts with washers.

In Design Specifications for Railway Structures and Commentary section 11.3.11, excepting for this clause, the thread on the pin should be metric fine thread (with a thread pitch of 4mm) in consideration of the possibility of loosening.
- (3) In the Specifications for Highway Bridges and Commentary, section 6.4 Pin Connections [Japan Road Association, 2002], structural details of members with pin holes are specified as follows:
 - 1) The difference between pin and hole diameter should be 0.5mm as standard for diameters less than 130mm and 1.0mm as standard for diameters greater than 130 mm.
 - 2) The net lateral sectional area of tensile members with pin holes should be greater than 140% of the calculated necessary net sectional area. And the net sectional area of tensile members behind pin holes should be greater than 100% of the calculated necessary net sectional area
 - 3) The web thickness of tensile members with pin holes should be 1/8 of the net width. The same regulation is specified in Design Specifications for Railway Structures and Commentary section 11.3.11 [Railway Technical Research Institute, 2000].

References in Chapter 11

Architectural Institute of Japan(1973) : Design Code for Steel Structure

Japanese Society of Steel Construction(1977) : Japanese Society of Steel Construction Standard for Groove

- Weld (JSS6-1977), JSSC VOL.13, NO.137
- Japan Road Association (1980) : Specifications for Highway Bridges and Commentary .
- Japan Society of Civil Engineers(1983) : Design Standard for National Railway Structures
- Toshihiko Momose, Kosuke Horikawa(1991) : Fatigue Strength of Laser-Cut Steel, Proceedings of the 46th Annual Conference of the Japan society of Civil Engineers, I-185
- Railway Technical Research Institute(2000) : Design Standards for Railway Structures and Commentary, Steel and Composite Structures 11.12 .
- Railway Technical Research Institute(2000) : Design Standard for Railway Structures and Commentary, Steel and Composite Structures and Design Standard for Steel Structures 14.7~14.9
- Railway Technical Research Institute(2000) : Design Standards for Railway Structures and Commentary, Steel and Composite structures .
- Japan Hydraulic Gate and Penstock Association(2001) : Technical Standard for Hydraulic Gate and Penstock, The Fourth Revised Edition
- Architectural Institute of Japan(2001) : Design Code for Steel Structure.
- Japan Road Association (2002) : Specifications for Highway Bridges and Commentary, II Steel Highway Bridges Volume 6.1.11 .
- Japan Road Association (2002) : Specifications for Highway Bridges and Commentary, II Steel Highway Bridges Volume 6.1.2 .
- Japan Road Association (2002) : Specifications for Highway Bridges and Commentary .
- Yoshinori KAMEI, Takashi NAKAMURA, Hisayuki AKIYAMA, Masahide TAKAGI, Nobuo NISHIMURA (2000) : An experimental study on slip strength of HSFG bolted joints of LP steel plate without uniform thickness portions, Journal of Structural Engineering, JSCE, Vol.64A, pp.1241-1250
- Kuniaki MINAMI, Takeshi MORI, Yoshiyuki NAKANO, Tatsuya YAMANO, Masato KOUSAKA, Yasukazu SHIMOYAMA, Eiichi YONEMOTO(2002) : A study on welding connections between cross beam and main girders in steel bridges, Proceedings of Japan Society of Civil Engineers, No.700/VI-54, pp. 65-70
- Japan Society of Civil Engineers(2003) : Special Subcommittee of Performance Based Design for Steel Structures, Committee of Steel Structures, Recommendation for Performance Based Design for Steel Structures
- Japan Society of Civil Engineers(2006) : Recommendations on Design, Construction and Maintenance for Friction Type of High Strength Bolted Connections
- Japanese Society of Steel Construction(2004) : Recommendation for Design of High Strength Tensile Bolted Connections for Steel Bridges
- Japan Bridge Association(2006) : Design Date Book
- Kuniaki MINAMI, Tadashi KASUYA, Chitoshi MIKI(2005) : A Study on Standard of Size of Fillet Weld, Quarterly Journal of the Japan Welding Society, Vol23, No.3
- AASHTO(1994) : AASHTO: LRFD Bridge Design Specifications (SI Units First Edition).
- CEN(2003) : CEN: EUROCODE 3 Design of Steel Structures prEN 1993-2.

Chapter 12 General Considerations for Framed Structures

12.1 Scope

This chapter applies to the design of framed structures such as trusses, rigid frames, arches and cable structures.

【Commentary】

In general, a truss is a structure in which the structural members are arranged such that the stability of the overall structure is achieved only based on the axial stiffness of each member. For the analysis of trusses in general, the axial force can be calculated assuming that the nodes are pinned joints. A rigid frame is a structure in which the structural members are arranged such that the stability of the overall structure is achieved based on the bending stiffness of each member. Axial forces, bending moment, and shear forces act on the members.

An arch is a structure in which straight or curved members (arch ribs) are united in a smooth, convex upward form that resists the primary load mainly through axial compression forces. In a long-span arch, attention should be paid to the geometrical nonlinearity that will make displacements or sectional forces greater than the values obtained by infinitesimal displacement theory.

A suspended structure, which commonly means cable structures such as suspension bridges and cable-stayed bridges, is a structure in which structural members are arranged such that the stability of the overall structure is achieved based on the axial stiffness of the cables as well as the axial and bending stiffness of the tower and girders, which are the primary structural members. In general, tensile forces act on the cables, while axial forces, bending moment, and shear forces act on the members comprising the tower and girders.

The terminology used here is that truss, rigid frame, or arch refers to the entire structure, while the structural members comprising the structure are called truss members, rigid frame members, and arch members, respectively. A framed structure is a structure in which truss members, rigid frame members, arch members, and others are combined in three dimensions so as to resist loading in three dimensions. Assuming that the stability of the entire structure can be achieved, a framed structure can be analyzed as a plane frame system

12.2 Member Section Design

12.2.1 General

The design of members constituting a framed structure shall be in accordance with Chapter 5~ Chapter 9 (Strength of Members, and Required Various Performance and Verification) and Chapter 10 (General Provisions Related to Structural Members).

【Commentary】

The overall structural stability, effective buckling length, and member composition of a section in a framed structure is prescribed in this chapter.

12.2.2 Design of truss members

12.2.2.1 Composition of sections

- (1) Cross section of members shall be such that the centroid of the cross section of the figure coincides with the center of the cross section as far as possible, and also coincides with the skeleton line.
- (2) The assembly of plates used in the composition of section shall be such that the welds will be as symmetrical as practicable about the vertical and horizontal axes of the section.
- (3) Chords, end posts and diagonal members attached to intermediate supports of continuous trusses, subject to compressive forces shall have box or π cross section, in principle, and the slenderness ratio related to radius of gyration about the vertical axis (outside the plane of the truss) shall be smaller than the corresponding ratio to radius of gyration about the horizontal axis (inside the plane of the truss).
- (4) The cross section of plates in a box section arranged parallel to the plane of the truss shall be greater than 40% of the gross section of the members.

【 Commentary 】

Truss members are constructed from box-section members assembled by welding, I-section members, steel pipes, shaped steel, members assembled from shaped steel, etc. Special attention needs to be paid to calculating strength, particularly if angle steel or CT steel is utilized, because eccentric joints tend to be formed at the nodes.

12.2.2.2 Effective buckling length of compression members

- (1) In-plane of truss
In principle, the length of the frame shall be taken as the effective buckling length of the member.
- (2) Out-of-plane of truss
If the member is effectively supported by supporting members in the out-of-plane directions or by in-plane supporting members, the distance between the supporting points shall be taken as the effective buckling length of the member.

【 Commentary 】

- (1) (1) The bending deformation of compression members of a truss, which is subject to the confining effect of adjoining members, exhibit the characteristics of compression members with elastically confined deflection angles at both ends when the focus is on a single compression member. The confining effect of adjoining members depends on the relative stiffness of the member in focus, the stress level of the adjoining members, details of the truss frame composition, and other factors, so it is difficult to prescribe a general effective buckling length factor. In this code, standard effective buckling length factors that err on the safe are provided by reference to Ultimate Strength and Design of Steel Structures [Japan Society of Civil Engineers, 1994], which refers to values specified in the design standards for each country presented in Table C12.2.1. If it is not possible to obtain the effective buckling length factor using the proper method, it is acceptable to adopt a value that is not less than 0.9 times the frame length in the case of a chord member or 0.8 times in the case of a web member.

If the midpoint of a member is effectively supported by another supporting member, its span may be used as the effective buckling length. Here, "effectively supported" means a situation in which the diagonal member is connected to the supporting member firmly enough, as shown in

Table C12.2.1 Comparison of effective buckling length factors with regard to in-plane buckling of a truss

Country/code	Chord member	Web member
USA AISC (1969)	1.0	1.0
Germany DIN4114 (1978)	1.0	0.9
Eurocodes 3 (1983)	1.0	0.9
Japan JSHB (1994)	1.0	0.8~1.0
Netherlands NEN3851 (1974)	1.0	0.7~1.0
Tchecoslovakia CSN (1976)	1.0	0.5~1.0
Belgium NBN B51-001 (1980)	0.9	0.9
France CM (1966)	0.9	0.8
Switzerland SIA161 (1979)	0.9	0.8
Great Britain BS5400 (1980)	0.85	0.7

Fig.C12.2.1 and the supporting member has been designed as a compression secondary member as defined in Chapter 10. In this case, the strength at the connection point of the diagonal member and the supporting member must be at least a quarter of the strength at the connection point of the diagonal member and the chord member.

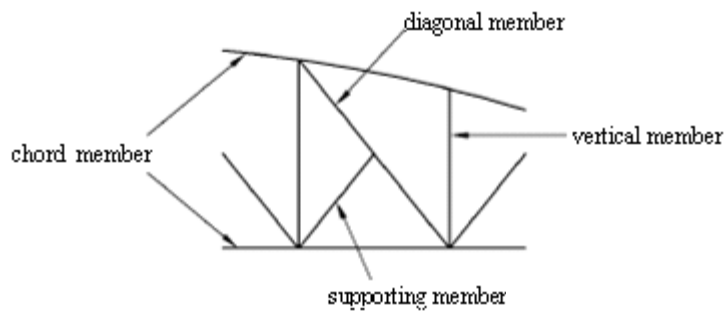
**Fig.C12.2.1 Members of a truss**

- (2) According to Reference and Handbook for Highway Bridges [Japan Road Association, 2002], "effectively supported" means a situation in which it is laterally supported by another member that can resist a force equivalent to 1% of the maximum compressive force that acts on the member. In a structure such as a pony truss and a single-chorded truss, in particular, it is necessary to connect the vertical member with other rigid members in order to prevent the bending stiffness of the vertical member from causing lateral buckling of the chord member, to say nothing of the stiffness of the vertical member itself. In Reference and Handbook for Highway Bridges, lateral buckling of the upper chord member is prevented by keeping the radius of gyration of area around the vertical axis at least 1.5 times as much as around the horizontal axis.

The out-of-plane effective buckling length of a truss with different axial forces, ℓ , is given by the equation below for L in Fig.C12.2.2:

$$\ell = \left(0.75 + 0.25 \frac{P_2}{P_1} \right) L \quad (\text{C12.2.1})$$

where , P_2 , P_1 are the compressive forces ($P_1 > P_2$) that act between nodes a-b and b-a, respectively. respectively.

If axial forces of opposite sign act in a vertical member of a K-truss, as shown in Fig.C12.2.3, and there is no supporting member outside the truss plane, the effective buckling length for L can be obtained using the equation below:

$$\ell = \begin{cases} \left(0.75 + 0.25 \frac{P_2}{P_1}\right) L, & P_1 \geq P_2 \\ 0.5L, & P_1 < P_2 \end{cases} \quad (C12.2.2)$$

where , P_1 is an absolute value of the compressive force, and P_2 is an absolute value of the tensile force, with a condition that the section between members a-a is uniform.

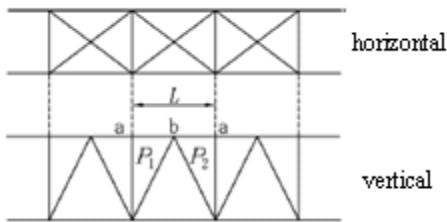

Fig.C12.2.2 Out-of-plane effective buckling length of chord members with different axial forces

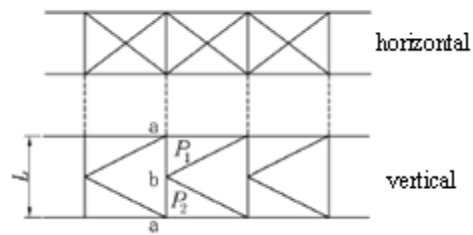

Fig.C12.2.3 Out-of-plane effective buckling length of vertical members with different axial forces

Effective buckling length factors of the main column members of a steel tower are presented for different frameworks and for different sectional compositions in Table C12.2.2.

The effective buckling length at the compressive foot of a steel tower should be studied not

Table C12.2.2 (1) Effective buckling length factors of the main column of a steel tower mainly subject to compressive force



















Effective buckling length factor	Framework				
			0.8	0.7	1.0
	0.9	0.85	1.0	1.0	
	Kx 1.0	1.0	1.0	1.0	
	Ky 1.0	0.5	1.0	1.0	
	Kx 1.0	1.0	1.0	1.0	
	Ky 1.0	0.5	1.0	1.0	

Table C12.2.2 (2) Effective buckling length factors of the main column of a steel tower mainly subject to bending compression

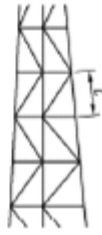
Effective buckling length factor		Framework			
					
		0.7	0.6	1.0	1.0
		0.85	0.8	1.0	1.0
		Kx 1.0	1.0	1.0	1.0
		Ky 1.0	0.5	1.0	1.0
		Kx 1.0	1.0	1.0	1.0
		Ky 1.0	0.5	1.0	1.0

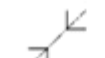
only at the nodes but also in terms of global corrugated buckling of the entire foot section and local buckling of chord members.

At nodes on the upper member of a pony truss, horizontal displacement is elastically confined by a lateral rigid frame consisting of vertical members and floor deck members. In evaluating the buckling load of an upper chord member, it should be noted that the axial compressive force that acts on it varies depending on the framework, as shown in Fig.C12.2.4, with the designed section of the members and the moment of inertia of the section changing accordingly.

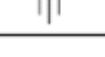
The effective buckling length of out-of-plane upper chords in the pony truss shown in Fig.C12.2.4 can be obtained from Eq.(C12.2.3).

$$\ell = \left(\frac{\lambda_0 + 1.8}{X_v^{0.4}} \right) a, \quad \ell \geq a \tag{C12.2.3}$$

$$\lambda_0 = \frac{1}{\pi} \frac{a}{r} \sqrt{\frac{F}{E}} \tag{C12.2.4}$$

- where , ℓ : effective buckling length
- a : spacing of U-shaped rigid frames
- r : radius of gyration of upper chord about the vertical axis
- F : nominal value of material strength (N/mm²)
- E : nominal value of Young's modulus (N/mm²)
- X_v : parameter for evaluating rigidity of U-shaped rigid frame of the pony truss,
given by $X_v = \frac{K_v a^3}{EI_c}$
- I_c : moment of inertia of section of central upper chord about the vertical axis of the chord

$$K_v = \frac{1}{\frac{h_1^3}{3EI_c} + \frac{bh_2^2}{2EI_b} + fh_2^2}$$

h_1, h_2 : heights of U-shaped rigid frame as shown in Fig.C12.2.4.

I_v, I_b : moment of inertia of section of vertical member and floor beam, respectively

f : deflection coefficient of part connecting vertical member and floor beam.

If the connection is made by unstiffened end plate or by bolts through

angle steel section, the coefficient is 0.5×10^{-10} rad/Nmm,

if the connection is made by bolts through stiffened end plate,

this coefficient is 0.2×10^{-10} rad/Nmm,

if the connection is adequately stiffened, and connected by welding or by

bolts, this coefficient is 0.1×10^{-10} rad/Nmm.

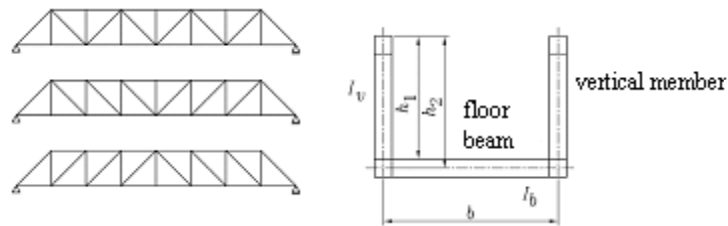

Fig.C12.2.4 Main structural configuration and cross section of pony truss

12.2.2.3 Built-up compression members

The design of built-up compression members formed by steel shapes shall be in accordance with the following.

(1) Slenderness ratio of built-up compression member

The slenderness ratio about the stronger axis and weaker axis of built-up compression member shall be calculated using the proper method.

(2) Shear force accompanying buckling of built-up compression member

Each part of the built-up compression member shall be designed assuming that a shear force acts on the part. During design, this shear force shall be added in addition to compressive force even in built-up compression members that are subject to only shear force.

(3) Structural details of combined compression materials

Structure details of combined compression materials shall be provided as appropriate.

【 Commentary 】

Recently, there have been fewer cases in which built-up compression members are used as the main structure of a bridge. Although usage is less frequent, this provision is retained in the code in case of need related to the maintenance or reinforcement of an old bridge. Furthermore, some built-up compression members used as parts of steel towers or steel columns used in construction utilize tie plates, etc.; these may not exactly be truss structures, but they are also included in this section. Since provisions relating to built-up members were deleted from [Reference and Handbook for Highway Bridges, February 1980], this section is based on Article 11.6 and its explanation in [Architectural Institute of Japan, 1980]. However, this does not mean to refute the contents of [Reference and Handbook for Highway Bridges, February 1980]. This commentary is also based on [Architectural Institute of Japan, 1980], though some terms have been modified.

(1) The slenderness ratio of a built-up compression member can be calculated using the following equations.

- 1) The slenderness ratio about the stronger axis (x-x axis in Fig.C12.2.5) of a built-up compression member is calculated using Eq.(C12.2.5) assuming the member to be a single member.

$$\lambda = \frac{\ell_k}{r} \quad (\text{C12.2.5})$$

where , ℓ_k : Effective buckling length (m)

r : Radius of gyration about the x-x axis (m)

- 2) The slenderness ratio about the weaker axis (y-y axis in Fig.C12.2.5) of a built-up compression member is calculated by proportionately increasing the slenderness ratio of Eq.(C12.2.5) for buckling. If the structural details of the built-up compression member are in accordance with subsection (2) below, the approximation of Eq.(C12.2.6) can be used.

$$\lambda_{ye} = \sqrt{\lambda_y^2 + \frac{m}{2}\lambda_1^2} \quad (\text{C12.2.6})$$

However, when , $\lambda_1 \leq 20$,

$$\lambda_{ye} = \lambda_y \quad (\text{C12.2.7})$$

can be considered.

Here , λ_y : slenderness ratio considering the built-up member as an integral member

λ_{ye} : effective slenderness ratio

m : number of steel shapes or sets of steel shapes formed by assembling connecting members (fitting strips, tie plates, lacing bars) (Fig.C12.2.6)

λ_1 can be obtained from the equation given below, according to the type of built-up compression member.

- a) Built-up compression member consisting of fitting strips or tie plates (Fig.C12.2.5)

$$\lambda_1 = \frac{\ell_1}{r_1} \quad (\text{C12.2.8})$$

where , ℓ_1 : Pitch of tie plates (m)

r_1 : Minimum radius of gyration of steel shape (m)

- b) Built-up compression member consisting of lacing bars (Fig.C12.2.7)

$$\lambda_1 = \pi \sqrt{\frac{A}{nA_d} \frac{\ell_d^3}{\ell_2 e^2}} \quad (\text{C12.2.9})$$

where , ℓ_2 : Component of length of lacing bar along the axis of the member (m)

ℓ_d : Length of lacing bar (m)

e : Distance between the central axes of the steel shapes (m)

A : Sum of sectional areas of steel shapes constituting the built-up compression member (m²)

A_d : Sectional area of lacing bar; however, in case of double lacing bars, this is the sum of sectional areas of all lacing bars (m²)

n : Number of connecting surfaces of connecting members (Fig.C12.2.8)

- c) Built-up compression member consisting of cover plates with holes (Fig.C12.2.9)

$$\lambda_1 = 1.7 \sqrt{\frac{\ell_1}{p} \frac{\ell_1}{r_1}} \quad (\text{C12.2.10})$$

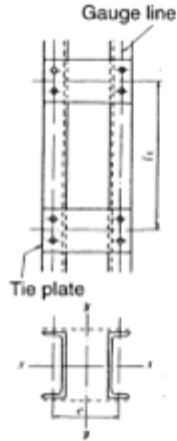

Fig.C12.2.5 Built-up compression members (tie plates)

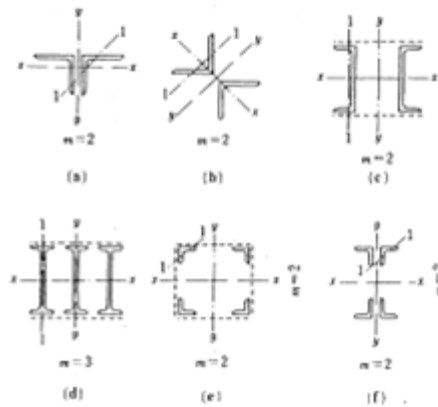

Fig.C12.2.6 Number of steel shapes

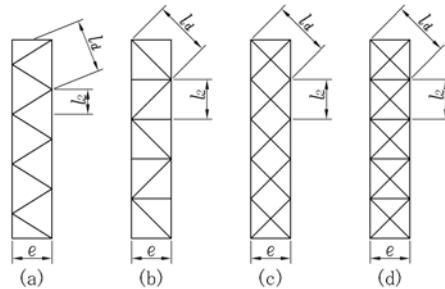

Fig.C12.2.7 Built-up compression members formed by lacing bars

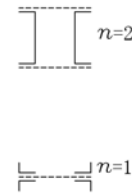

Fig.C12.2.8 n for lacing bars

- where , ℓ_1 : Length of hole (m)
- p : Hole pitch (m)
- r_1 : Minimum radius of gyration of built-up compression member at the hole position (m)

Buckling load at the non-solid-spandrel axis (y - y axis) of built-up members as shown in Fig.C12.2.5 is smaller than in the case where the two steel shapes act as one because of the effect of shearing deformation as built-up compression members. A commonly used equation to calculate approximately the effective slenderness ratio of such built-up members is given in Eq.(C12.2.6). Here, m in Eq.(C12.2.6) is the number of steel shapes or steel shape groups, and is counted as shown in Fig.C12.2.6. For built-up members of lacing bars, although λ_1 is to be calculated by Eq.(C12.2.9) (in Figs.C12.2.7 and C12.2.8), Eq.(C12.2.7) can be applied because λ_1 given by Eq.(C12.2.9) is less than 20 except in the case where the cross section of the lacing bar is extremely smaller than that of the steel shape.

Suppose Fig.C12.2.6(f) is a built-up compression member of lacing bars, λ_1 for x - x axis is calculated as a lacing bar type in Eq.(C12.2.9), while λ_1 for y - y axis shall be calculated as a fitting strip type in Eq.(C12.2.8). As for a built-up compression member of cover plates with holes as shown in Fig.C12.2.9, it shall be designed on the assumption that the cross section at the position of holes is the material for the built-up compression member. Eq.(C12.2.10) is based on the calculation method that is similar to the tie plate type, considering deformation as shown in Fig.C12.2.9(b). That is, the effective slenderness ratio is given by:

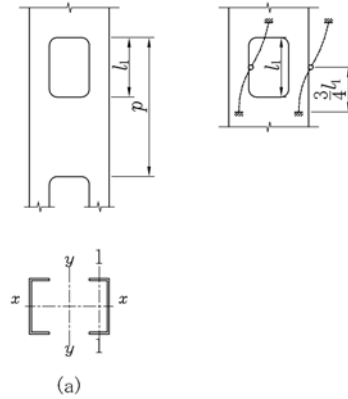

Fig.C12.2.9 Cover plates with holes

$$\lambda_{ye} = \sqrt{\lambda_y^2 + 2.77 \frac{\ell_1}{p} \left(\frac{\ell_1}{r_1} \right)^2} \quad (\text{C12.2.11})$$

therefore, if the following is assumed:

$$\lambda_1 = 1.67 \sqrt{\frac{\ell_1}{p} \frac{\ell_1}{r_1}} \quad (\text{C12.2.12})$$

Eq.(C12.2.12) will take the same form as in Eq.(C12.2.6). However, in a normal case, Eq.(C12.2.7) can be applied because λ_1 given in Eq.(C12.2.9) is less than 20.

- (2) There are a variety of ways to deal with shearing force that comes with buckling of built-up compression members, and provisions are different from country to country. One of those is Engesser's idea that tries to prevent failure of the tie rod until the straight built-up compression member subject to central compression is buckled and bent and the compressed steel shape reaches a yielding state. According to this idea, the ratio of shearing force Q_k to axial force N in the compression buckling increases along with the slenderness ratio as shown in Fig.C12.2.10. DIN is based on this idea.

On the other hand, based on the idea that eccentricities in opposite directions occur at both ends of a compression member and the tie rod will stay sound until they reach the bearing force, Q_k/N decreases as the slenderness ratio increases as shown in Fig.C12.2.10. In "Standards for Designing Steel Structure", following AISC (2%) and BS449 (2.5%), Q_k/N has been determined as 2%, regardless of the slenderness ratio.

Due to shearing force Q_k caused by buckling, the tie rod and its joint or the steel shape is subject to stress, so the safety measures shall be taken in the design. In this case, assumptions are made in calculation for grid built-up members, as shown in Fig.C12.2.11.

- (3) Structural details of built-up compression member
- 1) The pitch of high strength bolts or intermittent welds used for assembling the compression member shall be less than (cm) times the minimum thickness of the constituent members, and less than 30 cm (where, f_k : Nominal value of material strength (N/mm²)). However, if high strength bolts are staggered, the pitch on each gauge line shall be less than 1.5 times the value mentioned above. For the built-up compression member, regular bolts shall not be used except in unavoidable circumstances in order to ensure its stiffness.
 - 2) Since it is clear that just an additional tie plate at the midpoint shown in Fig.C12.2.8 will not increase the bearing force, the number of spacing into which fitting strips, tie plates or lacing bars are divided shall be greater than three, following DIN. The length of all spacing shall be taken as equal as possible.

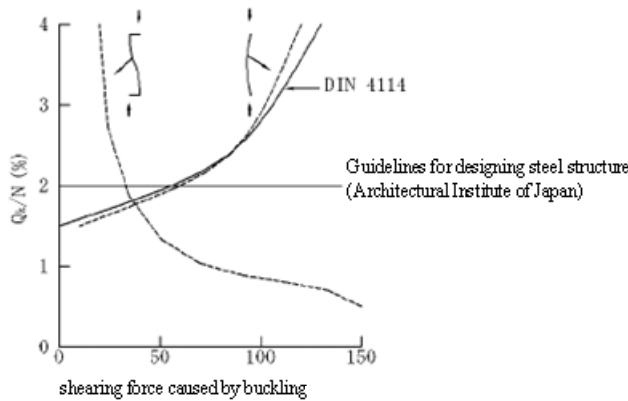

Fig.C12.2.10 Ratio of shearing force Q_k to axial force N

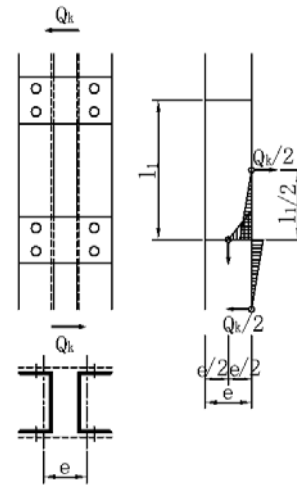

Fig.C12.2.11 Q_k of a girder combination member

- 3) Since errors in the unsafe side that are given in Eq.(C12.2.6) are not negligible if the slenderness ratio of tie plates exceeds 50, the length of each space shall be taken so that the slenderness ratio of steel shapes of fitting strips and tie plates becomes less than 50. In cross-shaped sections, fitting strips shall be arranged alternately perpendicular to each other. In lacing bars, the length of the section shall be taken such that the slenderness ratio of steel shapes becomes less than the larger of the slenderness ratios of the two main axes of the built-up member.
- 4) The slenderness ratio of the lacing bar shall be less than 160. In AISC and BS, it shall be less than 140.
- 5) The ends of a built-up compression member with large spacing between steel shapes shall be connected by gusset plates or tie plates with adequate rigidity using more than 3 high strength bolts, or by welds that offer stronger connections than with high strength bolts. The pitch of high strength bolts used in this part shall be less than four times the diameter of the bolts. In case of welds, continuous welds shall be used. Since, as shown in Fig.C12.2.6(c)~(f), this is for the purpose of preventing a gap between steel shapes at the end of the member with large spacing between steel shapes, structures shown in Fig.C12.2.6(a) and (b) are excluded.
- 6) In cover plates with holes, the length of the hole shall be less than twice its width. The distance between inside edges of adjacent holes shall be greater than the distance between adjacent high strength bolts or distance between adjacent weld lines of the built-up member. A radius of corner-part of holes shall be greater than 50 mm.

12.2.2.4 Member with direct load

When a load acts to the place besides nodes, bending moment will happen except axial force in the member. This is valued appropriately in consideration of itself.

【 Commentary 】

If direct external forces act between panel points of a chord member of truss, bending moment and shear force will act on the chord member in addition to the axial force. To deal with these in designing, it is necessary to consider, for example, the sectional forces which act on the chord member

as multi-span continuous girders that are supported in a vertical member. This type of structure includes upper chord member of a deck type truss which directly supports the deck and steel shell Caisson-type ring frame truss which is subject to hydraulic pressure.

12.2.3 Design of rigid frame members

12.2.3.1 Effective buckling length

The out-of-plane and in-plane effective buckling lengths of frame members shall be computed by a suitable method.

12.2.3.2 Members with axial compression forces and bending moments

The method of safety examination for members subjected to combined axial compression forces and bending moments is given in Chapter 6.

12.2.3.3 Examination of composition of bending, axial forces, and shear forces

The method of safety examination for members subjected to bending, axial forces, and shear forces is given in Chapter 6.

12.2.3.4 Influence of foundation structure

The influence of rotation and relative movement of the foundation must be considered in the design.

【 Commentary 】

(1) Out-of-plane buckling

The effective buckling length of column members against in-plane buckling of rigid frame may be calculated using Eq.(C12.2.13).

$$\ell = Kh \quad (\text{C12.2.13})$$

where , h : Height of column in rigid frame (m)

K : Effective buckling length coefficient, obtained from Eq.(C12.2.14)
or (C12.2.15)

(1-1) Sway buckling (Refer to Fig.C12.2.12(a))

$$K = \sqrt{\frac{1.6 + 2.4(\xi_1 + \xi_2) + 1.1\xi_1\xi_2}{\xi_1 + \xi_2 + 5.5\xi_1\xi_2}} \quad (\text{C12.2.14})$$

(1-2) Non-sway buckling (Refer to Fig.C12.2.12(b))

$$K = \frac{3 - 1.6(\xi_1 + \xi_2) + 0.84\xi_1\xi_2}{3 - (\xi_1 + \xi_2) + 0.28\xi_1\xi_2} \quad (\text{C12.2.15})$$

where ,

$$\left. \begin{aligned} \xi_1 &= \frac{1}{1 + G_t} \\ \xi_2 &= \frac{1}{1 + G_b} \end{aligned} \right\} \quad (\text{C12.2.16})$$

$$G = \frac{\sum(I_c/h)}{\sum(XI_b/L)} \quad (\text{C12.2.17})$$

where , I_c, I_b : Moment of inertia of section of column and beam (m⁴). Average value used

if the cross section of the member is variable

- L : Length of beam (m)
 \sum : Indicates summation of the members that are assembled at the upper and lower ends of the column
 X : Value given in Table C12.2.3 according to the connecting conditions on the other end of the beam

Table C12.2.3 Value of X

Beam and condition	Hinged	Rigid	Fixed
Sway buckling	0.5	1.0	0.667
Non-sway buckling	1.5	1.0	2.000

Depending on the boundary conditions of the column, the values of G_b to be used shall be as follows:

Bottom end hinged : $G_b = \infty$, Bottom end fixed : $G_b = 0$

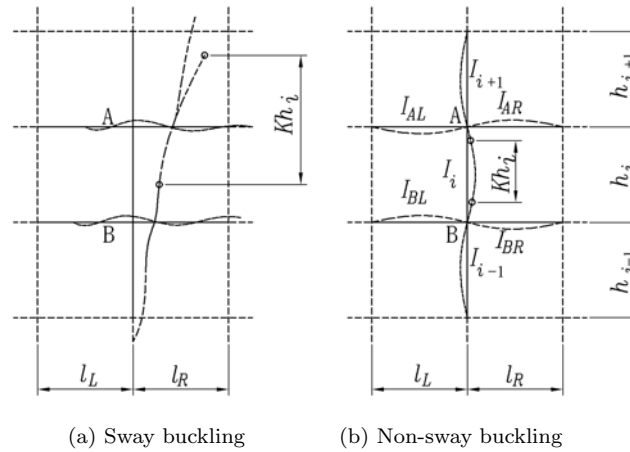

Fig.C12.2.12 Buckling of multi-storey framework

(2) Out-of-plane buckling

The effective buckling length for out-of-plane buckling of rigid frame of almost equal sections may be taken as twice the total height of the frame. In a rigid frame where the cross section varies considerably, or where the rigid frame is of special structure, the effective buckling length shall be determined separately as given in paragraph 12.2.5.

While the calculation formula provided in many design standards is based on the stiffness ratio of the column to the beam, $G = (I_c/h)/(I_b/L)$, it has been pointed out that the evaluation may be too much on the safe side in the range of $K < 0.5$ which is actually utilized for rigid frame structure. Hence, a calculation method based on approximation of effective buckling length factors has been adopted [Japan Society of Civil Engineers, 1994]. This method is to be applied if symmetric rigid frame is subject to symmetric loads. For special structure types, complex loading conditions, or changing cross sections, eigenvalue analysis in subsection 12.2.5 can be utilized to calculate the effective buckling length.

12.2.4 Design of arch members

12.2.4.1 Effective buckling length

The effective in-plane and out-of-plane buckling length of arch members shall be calculated using the proper method.

【 Commentary 】

Since there are arch structures of various types, it is difficult to define uniquely an effective buckling length for both member buckling and global buckling. In out-of-plane buckling, in particular, member buckling and global buckling often occur independently of each other; hence, the effective buckling length of members is defined as below on condition that global buckling will be checked in accordance with the later subsection 12.2.4.

(1) In-plane buckling

The effective buckling length for the in-plane buckling of arch members in an arch structure where no axial forces act on the stiffening girders and the unstiffened arch may be calculated using Eq.(C12.2.18). The effective buckling length of arch members in an arch structure where axial forces do act on the stiffening girders should be taken as the panel length.

$$\ell_e = \frac{\pi L}{\sqrt{\alpha\gamma}} \quad (\text{C12.2.18})$$

where , L : effective span of arch

$$\gamma : \gamma = \sqrt{1 + 4 \left(\frac{f}{L}\right)^2}$$

f : rise of arch

α : in-plane buckling coefficient of arch given in Table C12.2.4

Table C12.2.4 In-plane buckling coefficient

Type of structure		f/L	α					γ	
			0	0.10	0.15	0.20	0.30		
Unstiffened arch	Two-hinge arch		39.5	36.0	32.0	28.0	20.0	9	
	Fixed arch		81.0	76.0	69.5	63.0	48.0		
Two-hinge arch in which axial forces do not act on the stiffening girder	If a side span does not exist		39.5	36.0	32.0	28.0	20.0	12	
		If a side span exists	λ	0	81.0	76.0	69.5		63.0
	0.25		63.0	58.5	52.5	47.0	34.5		
	0.50		55.5	51.5	46.5	41.5	30.5		
	0.75		51.5	48.0	43.0	38.5	28.5		
	1.0		49.0	45.5	41.0	36.5	27.0		
2.0	45.0	41.0	36.5	32.0	22.5				

$$\lambda = \frac{a}{L} \left(1 + \frac{I_a}{I_g}\right) \quad (\text{C12.2.19})$$

where , a : side span length of stiffening girder (m)

L : effective span of arch (m)

I_a : average value of moment of inertia of arch member on one side of the arch against in-plane bending of arch (m⁴)

I_g : average value of moment of inertia of section of stiffening girder on one side of the arch (m⁴)

If the value of f/L and λ falls between the values given in Table C12.2.4, then α must be calculated by linear interpolation.

Eq.(C12.2.18) calculates effective buckling length based on the section at $L/4$ assuming a nearly uniform section in the axial direction of the member; thus, it is considered as the representative value for the whole arch structure. In the case of arch bridges, the effective buckling length

factor $\pi/\sqrt{\alpha\gamma}$ takes a value between 0.12 (for fixed arch with $f/L = 0.1$) and 0.23 (for 2-hinged arch with $f/L = 0.3$) [Japan Road Association 2002], Reference and Handbook for Highway Bridges). In some cases it is larger than the interval between nodes (around $0.1\sim 0.2L$) of a regular arch bridge. In designing the section of a member, the effective buckling length obtained by eigenvalue analysis at each section would be the most suitable value to use, but this equation may be utilized because it gives a good approximation in an explicit form without the need for eigenvalue analysis when the member section is uniform in the axial direction. General design is possible for section if a beam or a column with this effective buckling length is assumed.

Since the in-plane load-carrying capacity of the overall structure will greatly decrease if loading is uneven in the axial direction of the member, overall buckling should be verified, as explained later in Section 12.4, for the case of an unstiffened arch bridge or an arch structure where no axial force acts on the stiffening girder. In the case of an arch where axial force acts on the stiffening girder, the in-plane load-carrying capacity of the overall structure is great enough that little problem arises, but the buckling of a member between nodes becomes dominant; hence, the panel length is taken as the buckling length.

(2) Out-of-plane buckling

The effective buckling length for out-of-plane buckling of an arch member should be taken as the panel length. However, if the arch is supported in the transverse direction by adequately stiffened members with the purpose of restraining it in the transverse direction, the distance between supports may be considered as the effective buckling length.

12.2.4.2 Verification of in-plane load carrying capacity of arches

Arch members shall be designed as members subject to axial compressive forces and bending moments.

【 Commentary 】

The design of an arch rib consists of verifying overall safety in terms of overall buckling and also verifying the member in terms of buckling between panel points. The latter type of buckling tends to occur more often as axial force becomes more dominant and the slenderness ratio of the arch member increases; further, it tends to occur at the end panel point close the support point.

In designing an arch member between the panel points, the length of the member (length between nodes) is considered the effective buckling length for the sectional forces in the structure system as a whole and verification is based on the provisions of Chapters 6 to 9. The panel points here are those of the arch rib effectively supported by the support member in the buckling direction. However, for a structure in which the arch ribs are supported by cable, such as in the case of a Nielsen Bridge, the effective buckling length must be specially verified through elastic eigenvalue analysis as described in subsection 12.2.5.

Structures such as circular arches, which are subject to distributed loading such as centripetal loads, and parabolic arches, which are subject to uniformly distributed loading per unit length in the span direction, may, as an approximation, be analyzed assuming that only axial compressive forces act. Even for other regular arches, the axial compressive forces become the dominant member force if the arch rise ratio is small and the slenderness ratio of the member is large. In such cases, an axial force member may be assumed in design.

For details, refer to the provisions of Chapter 13 of Reference and Handbook for Highway Bridges [Japan Road Association, 2002]. In addition, equations for verifying the in-plane load-carrying capacity of an arch structure as a whole are proposed in Ultimate Strength and Design of Steel Structures [Japan Society of Civil Engineers, 1994].

12.2.4.3 Verification of out-of-plane buckling of arch

Out-of-plane buckling of arches shall be verified using the proper method.

- (1) The safety against out-of-plane buckling of arches formed by one main arch structure and the safety of out-of-plane buckling of arches in which the spacing of two main arch structures is small compared to the effective span, shall be verified.
- (2) Out-of-plane buckling of arches shall be verified against the most critical loading conditions.
- (3) Lateral bracings and sway bracings of arch shall be designed in accordance with section 12.4.

【Commentary】

The following methods are available for the verification of out-of-plane buckling of arches.

- (1) (1) If two or more main arch structures, the sections of which have been determined in consideration of safety against the buckling of members between panel points, are stiffened with lateral braces and sway bracing as directed in the provisions of section 12.4 and if the ratio of span to the distance between the outermost main structures is 20 or less, it is generally not necessary to verify out-of-plane buckling in the complete system. This is applicable also to so-called basket-handle Nielsen Lohse girder bridges where the surfaces of the two arch structures are slanted with respect to each other, even though the provisions of section 12.4 indicate that it is not applicable.

For other cases, verification is prescribed because there is a risk of lateral buckling in the out-of-plane direction of the arch when the entire structure system is considered.

If three-dimensional eigenvalue analysis is not conducted, the effective buckling length factor can be calculated as an explicit function by defining λ as in the following equation.

$$\lambda = \frac{1}{\pi} \sqrt{\frac{F}{E} \frac{K_e K_\beta K_t K_g S}{r_y}} \quad (\text{C12.2.20})$$

where, r_y : $\sqrt{I_y/A}$

I_y : moment of inertia of section around the vertical axis of an arch rib (mm^4); in the case of variable section, it is the average over the length $I_y = \sum I_{yi} L_i / L$,
 $L = \sum L_i$

K_e : effective buckling length factor to take into account the confining effect of the support point; it is 0.5 if out-of-plane bending gyration of the arch rib at the supporting the support point is restrained and 1.0 otherwise.

K_β : effective buckling length factor to take into account the effect of stiffening by lateral braces,

$$K_\beta = 1 - \beta + \{2r_y(0.5 + 0.94\sqrt{u})/(aK_e)\}\beta$$

β : ratio of the length of the arch part stiffened by lateral braces to the total length of the arch rib; for through-arch bridges (Fig.C12.2.13) it is the ratio of the length of the part of the arch stiffened by lateral braces to the total length of the arch rib, while for half-through arch bridges (Fig.C12.2.14) it is calculated in a similar way by regarding the upper part (above the base of the portals) as a through-type bridge. For deck-type arch bridges (Fig.C12.2.15), $\beta = 1.0$ because the entire arch is usually stiffened by lateral braces.

α : distance between axes of the two arch ribs (mm)

μ : factor representing shearing deflection of the lateral bracings,

$$\mu = \frac{1}{2} \left(\frac{a}{L}\right)^2 \left(\frac{a}{b}\right) \left(\frac{A}{2A_d}\right) \left[\left\{ 1 + \left(\frac{a}{b}\right)^2 \right\}^{3/2} + \frac{2A_d}{A_b} \right]$$

b : panel length of the lateral braces (mm); if variable, the average should be taken.

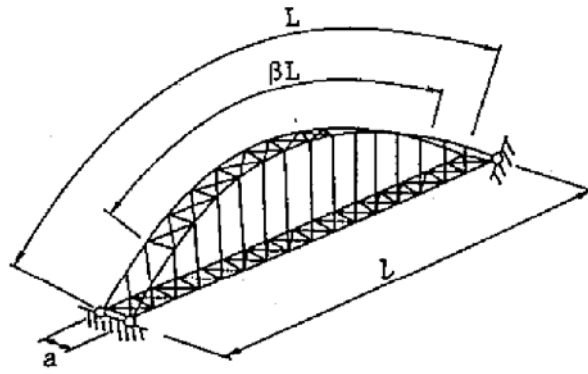

Fig.C12.2.13 Through type arch

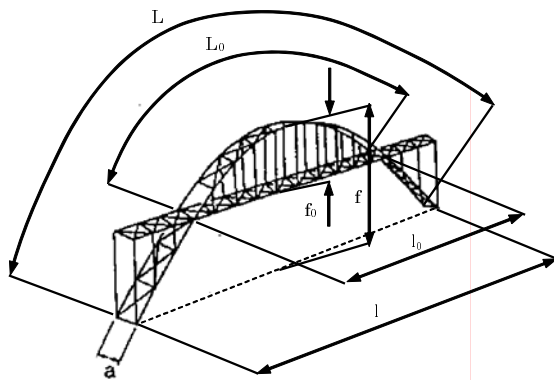

Fig.C12.2.14 Half-through type arch

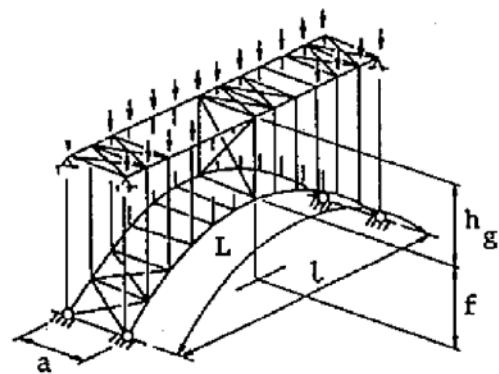

Fig.C12.2.15 Deck-type arch

- A_d : sectional area of the diagonal members of lateral braces (mm^2)
- A_b : sectional area of the struts of lateral braces (mm^2)
- K_ℓ : effective buckling length factor to be considered if the loading direction does not remain vertical; it is 1.0 if loading is always vertical. For through-arch bridges and half-through arch bridges,

$$K_\ell = \begin{cases} 1 - 0.35 \left(\frac{I_{gy}}{I_{ay}} \right)^{1/4} & \frac{I_{gy}}{I_{ay}} \leq 1 \\ 0.65 & \frac{I_{gy}}{I_{ay}} > 1 \end{cases}$$

For deck-type arch bridges,

$$K_\ell = 1.45 + 0.05 \frac{I_{ay}}{I_{gy}} + \left(0.01 \frac{h_g}{f} \frac{I_{ay}}{I_{gy}} \right)^{0.25}$$

- I_{gy} : moment of inertia of section in terms of horizontal lateral bending of the section of the structure including girders and floor system, if any (mm^4)
- I_{ay} : moment of inertia of section in terms of out-of-plane bending of the section of the structure including the two arch ribs that are connected by lateral braces (mm^4)
- h_g : vertical distance between the center line of the stiffening girder and the arch crown (center) in the case of a deck-type arch bridge (mm) (Fig.C12.2.15)
- f : arch rise (mm)

K_g : effective length factor to take into account the effect of confinement of out-of-plane displacement of the arch by stiffening girders; if $K_g = 1.0$, it is on the safe side for all cases. In the case of through-arch bridges and half-through arch bridges, $K_g = 1.0$ is usually assumed. In the case of deck-type arch bridges, if the arch ribs and stiffening girders are rigidly connected at the arch crown and an increase in strength is considered, the calculation may be based on the following equation:

$$K_g = 0.5 + \frac{1.48}{\left(\frac{I_{gy}}{I_{ay}} + 1.72\right)^2}$$

S : total axis length of arch (cm); in the case of through-arch bridges and deck-type arch bridges, it is the total axis length L of the arch, while in the case of half-through arch bridges it is the axis length L_0 of the arch from the base of one portal to the base of the other portal (Fig.C12.2.14)

σ_{cul} : local buckling strength of the plates composing the section (N/mm²)

For an arch where the arch axes are in the vertical plane, the arch shapes are symmetrical parabolas or circular arcs, the structural members of the arches are almost the same height, and the structure as well as the sway bracing are designed in accordance with subparagraph 12.2.4.3, then out-of-plane buckling of the arch may be verified using the following equation:

$$\gamma_i \frac{N_{sd}}{P_{cud}} \leq 1.0 \quad (\text{C12.2.21})$$

where , N_{sd} : design axial force on supports calculated from first-order elastic theory for loads (uniformly distributed loads) acting on the structure; in the case of a half-through arch bridge, this is the axial force on the arch ribs at the point of intersection of the arch with the stiffening girder (N)

P_{cu} : design resistance in compression:

$$P_{cud} = \frac{A\sigma_{cug}\sigma_{cul}}{\gamma_b f_{ud}}$$

A : cross-sectional area of one arch rib; in case of a variable cross section,
: the average value of sectional area along the length

$$A = \sum A_i L_i / L, \quad L = \sum L_i$$

f_{ud} : specified design strength (N/mm²), f_{yd}/γ_m

σ_{cug} : axial compressive strength without considering local buckling; can be obtained from the equation below (N/mm²)

$$\sigma_{cug} = \begin{cases} f_{ud} & (\lambda \leq 0.2) \\ \{1.0 - 0.545(\lambda - 0.2)\} f_{ud} & (0.2 < \lambda \leq 1.0) \\ \frac{1}{(0.773 + \lambda^2)} f_{ud} & (1.0 < \lambda) \end{cases}$$

λ : Slenderness ratio parameter

$$\lambda = \sqrt{\frac{A_s f_{yk}}{\kappa N_s}} = \sqrt{\frac{A_s f_{yk}}{N_{cr}}}$$

A_s : cross-sectional area of arch rib at support

κ : minimum eigenvalue for out-of-plane buckling obtained from paragraph 12.2.5

N_{cr} : critical buckling load at the support

- ” In terms of gyration about the horizontal axis at the support point of the arch rib (whether it is hinged within the plane of the arch or fixed), its effect on out-of-plane buckling strength is small.
- ” As to how to deal with coupled buckling along with local buckling of the plates composing

the cross section, this is handled as for straight columns.

- " Axial compressive strength around the vertical axis, if local buckling is not considered, can be calculated by substituting the slenderness ratio parameter obtained for the arch structure into the equation for axial strength of a straight member.

Lateral braces and sway braces should be designed for the arch in accordance with section 12.4. However, if the forces in the diagonal members of the end lateral bracing are calculated using the conventional simplified method, the slenderness ratio must be made less than 60.

- (2) Out-of-plane buckling of arches must be verified against the most critical loading conditions with the maximum axial force. Concentrated loads are generally small and therefore can be omitted. In principle, the loading condition shown in Fig.C12.2.16 should be verified. If the ratio of this load to the uniformly distributed load is large, calculation of axial forces at the support points should be considered.

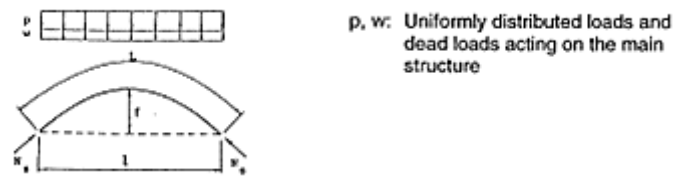

Fig.C12.2.16 Loading condition used for verifying out-of-plane buckling loads of arch

In the verification, the following points may be considered:

- " In terms of gyration about the horizontal axis at the support point of the arch rib (whether it is hinged within the plane of the arch or fixed), its effect on out-of-plane buckling strength is small.
 - " As to how to deal with coupled buckling along with local buckling of the plates composing the cross section, this is handled as for straight columns.
 - " Axial compressive strength around the vertical axis, if local buckling is not considered, can be calculated by substituting the slenderness ratio parameter obtained for the arch structure into the equation for axial strength of a straight member.
- (3) Lateral braces and sway braces are usually designed in consideration of the horizontal lateral loads (which act out of the plane of the arch) caused by earthquakes or wind. Hence, lateral bracing members are designed independently of out-of-plane buckling of the arch; and buckling of the members may occur before the entire structure system reaches the ultimate state. In addition, it is evident that excessive axial forces that cannot be calculated using conventional methods will act on diagonal members of the end lateral bracing. For these reasons, the following prescription is given.

If the forces in the diagonal members of the end lateral bracing are calculated using the conventional simplified method, the slenderness ratio must be set at less than 60. Although this maximum slenderness ratio of 60 is not a value that has been obtained theoretically, it is confirmed in Ultimate Strength and Design of Steel Structures [Japan Society of Civil Engineers, 1994] that the safety of this design method has been verified through numerical experiments with variable parameters. Though it is true that a more rational way of design is to calculate member forces separately using a more rigorous method, the situation is conveniently expressed in terms of the slenderness ratio in order to avoid design complication.

Arch bridges that do not meet the conditions stipulated above must be separately verified. To do this, verification of strength through three-dimensional finite element elasto-plastic analysis is the desirable method.

If the support points of the arch undergo rotation as out-of-plane bending and torsion occur, the

out-of-plane buckling strength will be significantly lower; if out-of-plane bending and torsion is to be restrained, little play and looseness should be allowed in the structure and construction requires adequate care.

12.2.5 Calculation of effective buckling length by eigenvalue analysis

For structures which are difficult to calculate the effective buckling length from equations given in subparagraphs 12.2.2.2, 12.2.3.1, and 12.2.4.1, the effective buckling length of each section can be calculated by eigenvalue elastic analysis of the entire structure using eq.(12.2.2).

$$|K_E + \kappa K_G(N_i)| = 0 \quad (12.2.1)$$

$$\ell_{ei} = \pi \sqrt{\frac{(EI)_i}{\kappa N_i}} \quad (12.2.2)$$

- Here, K_E : Elastic stiffness matrix of the micro-displacement theory.
 K_G : Geometric stiffness matrix in the standard state
 κ : Eigenvalue
 ℓ_{ei} : Effective buckling length of cross section i (m)
 $(EI)_i$: Flexural stiffness of cross section i (kNm²)
 N_i : Design axial force of cross section i obtained from structural analysis based on the design loads (kN)

【 Commentary 】

The effective buckling length of a structural member varies according to loading conditions and support conditions, so it is very difficult to uniquely determine the effective buckling length of a complex structural system with varying cross sections. In the existing design standards [Japan Road Association, 2002; Railway Technical Research Institute, 2000; and Japan Society of Civil Engineers, 1987], effective buckling length is defined in an explicit form in terms of representative structures and boundary conditions; there is no clear prescription for any arbitrary structural system. Therefore, in actual design, there are cases where the effective buckling length is an approximate value determined at the discretion of the design engineer. This may lead to a situation in which safety against buckling is not adequate. Taking the above into consideration, this code provides methods for determining the effective buckling length of a member section not only by the deterministic method of subparagraphs 12.2.2.2, 12.2.3.1, and 12.2.4.1 but also by elastic eigenvalue analysis of the total structural system based on the loading provisions of Chapter 2. Now that computers have come into use for everyday practical design work, elastic eigenvalue analysis is no longer a burden when designing a complex steel structure. Although the calculations are more complicated than the conventional method, the effective buckling length can be calculated for any arbitrary framed structure that is subject to certain loads. Furthermore, by setting nodes at points where the section changes, effective buckling length can be defined for the section between the nodes, thus making possible enhanced design precision and reliability.

If, for all structural members, the stiffness, boundary conditions, and loading conditions are given, the effective buckling length given by Eq.(12.2.2), which is obtained through eigenvalue analysis in Eq.(12.2.1), is generally more precise compared with the effective buckling length determined using the conventional method based on the stiffness of adjoining members. However, from the viewpoint of practical design, an enormous numbers of eigenvalue analyses would be needed to find the most disadvantageous loading condition for each targeted member, while dealing with effective buckling

length would become complicated because the effective buckling length varies with member cross section where it is not constant.

Furthermore, in certain structural systems, such as those with microscopic axial compressive forces, those with member cross sections that vary significantly, and so on, the effective buckling length of a member takes an unrealistically large value with an extremely big slenderness ratio. In some cases, the value is so extreme as to make design impossible [Japan Society of Civil Engineers, Ultimate Strength and Design of Steel Structures, 1994] [Nishino, et al., Bridge and Fundamentals, 1981]. Certain countermeasures are currently available for this, such as a method involving the introduction of an additional axial compressive force to a section subject to microscopic axial compressive forces, a method of evaluating a higher-order buckling mode in which only the focused member reaches buckling, a method that avoids reliance on loading, and so on; however, none has become the accepted standard method. Hence, it is necessary to properly evaluate the effective buckling length while comparing various analysis methods and making an evaluation on the safe side with respect to eigenvalue analysis.

12.3 Verification of Entire Structure

In framed structures such as truss, rigid frame, arch, and cable structure, not only the safety of each member and joint but also the safety of the entire structure shall be verified.

【Commentary】

(1) Trusses

In trusses where the spacing of the main truss structures is very close compared to the total length of the truss, or in pony trusses with small transverse rigidity, overall buckling must be verified using appropriate methods. If truss girders with a pseudo-box section consisting of a main structure with upper and lower lateral braces have a ratio of span to distance between main structures that exceeds 30, the transverse rigidity and torsional rigidity will be small and may cause overall lateral buckling. For verification methods in these cases, it is recommended to refer to Guidelines for Design against Buckling [Japan Society of Civil Engineers, 2005], Handbook for Design of Steel Road Bridges [Japan Road Association, 1980], etc.

In pony trusses, the lateral buckling strength of the upper chord member must be calculated and designed by properly considering the rigidity of the U-frame comprising the vertical members, diagonal members, and cross beams that support the upper chord member. If the ratio of span to distance between main structures exceeds 10, it is desirable to conduct an elastic buckling analysis for the entire structural system to verify safety.

(2) Rigid frames

Generally, if a rigid frame is designed in accordance with section 12.2, it is not necessary to verify total buckling of the frame; however, if a non-standard frame type is used, separate detailed calculations are necessary to verify total buckling of the frame. For non-standard types of rigid frame, elastic buckling analysis of the entire structure must be conducted to verify total buckling and to calculate the effective buckling length of members.

(3) Arches

The overall arrangement of the structure, its shape, and the cross sections of its members should be selected so that total in-plane and total out-of-plane buckling of the arch does not occur. For an unstiffened arch in which eccentric loads act in the axial direction and for an arch structure in which the stiffening girder is subject to no axial force, care must be taken with regard to total in-plane buckling. In addition, in an arch structure where there is a possibility of lateral buckling in the out-of-plane direction, total buckling must be verified. In this case, it

is desirable to verify the strength through elasto-plastic finite displacement analysis. For details of the method, refer to section 12.2.

(4) Cable structure

Generally, if the cross section is designed according to section 12.2, it is not necessary to verify total buckling of the cable structure. However, the loading capacity of the cross sections of towers, girders, and cables of the main structural components of large suspension bridges and cable-stayed bridges must be verified to confirm safety using three-dimensional models of the entire structural system. The various loads that act on the upper structure of a typical suspension bridge or cable-stayed bridge are transmitted to the tower via cables and then to the foundation. Therefore, this verification of the safety of main girders, cables, and towers is extremely important. For large suspension bridges, in particular, safety must be verified not only through specification of required safety performance and its verification as explained in Chapter 6, but also through elastic finite displacement analysis and elasto-plastic finite displacement analysis using a three-dimensional model of the entire structure. In investigating the buckling of towers and stiffening girders in suspension bridges and cable-stayed bridges and also the load carrying capacity of the entire structural system, Guidelines for Design against Buckling [Japan Society of Civil Engineers, 2005] can be referred to.

Attention shall be paid to fewer steel girder bridges because recent studies have concluded that verification of total buckling is necessary in construction.

Attention shall be paid to fewer steel girder bridges because recent studies have concluded that verification of total buckling is necessary in construction.

12.4 Constraint in the Transverse Direction

In trusses or arch structures, lateral bracings and sway bracings adequately stiffened in the transverse direction shall be provided for insuring structural functions in three dimensions. If such measures are not provided, the structure shall be calculated separately as a three-dimensional framework and safety shall be verified.

【 Commentary 】

In designing truss and arch members for a bridge, the effective buckling length with respect to out-of-plane buckling of compressive members is calculated on the premise that the panel points of the main structure are sufficiently supported by lateral braces, sway braces, portal braces, etc. The design of these lateral braces, struts, sway braces, and portal braces is based on section 12.5 of Reference and Handbook for Highway Bridges [Japan Road Association, 2002].

In order to obtain precise values of the forces acting on the diagonal members in the lateral bracing of an arch, while it is desirable to conduct (elastic) finite displacement analysis for the arch system and the lateral bracings as a three-dimensional framework, an alternative method is available as follows. For horizontal lateral loading, assuming that the arch system and the lateral braces form a plane framework, finite displacement analysis is conducted by setting an arch axial force from the in-plane design loads imposed by earthquakes or storms along with the horizontal lateral load multiplied by a coefficient. For vertical in-plane loading, assuming a three-dimensional framework of arch ribs and lateral braces, microscopic displacement analysis is conducted using the vertical design load multiplied by a coefficient. Of the two member forces calculated for each load, the larger one is selected and design is carried out assuming a straight column.

12.5 Camber

In structures where the finished shape must be maintained, a manufacturing camber shall be provided, in principle.

【Commentary】

While it is common to provide a manufacturing camber to account for the dead load (fixed load), in a composite structure or composite girder of steel or concrete a manufacturing camber should also be provided for hard dry shrinkage and creep as well as deflection due to concrete pre-stressing.

In Standards and Handbook for Designing Railway Structures - Steel/Composite Structures (SI unit version) [Railway Technical Research Institute, 2000], the rule is to provide a manufacturing camber for the purpose of avoiding unfavorable effects in terms of ride comfort and safety and preventing sag of the bridge girders due external dead loads. In the case of plate girders, it is a rule to provide a manufacturing camber for a bridge girder with a span over 30 m to deal with the deflection caused by the dead load of the main girder; in some cases it is better to provide a camber also for a bridge girder with a span of less than 30 m if deflection resulting from the dead loads is particularly large. In addition, part of the train load should be considered in the case of an open deck bridge girder carrying a railway. In the case of composite girders, it is a rule to provide a camber for the steel girder against deflection caused by the dead load regardless of span.

On the other hand, in Reference and Handbook for Highway Bridges [Japan Road Association, 2002], there are no provisions as to the span length.

12.6 Members Considered as Substructure

Members considered to possess properties of a substructure, such as the base of a column in a rigid frame, shall be designed carefully with a view to points such as selection of design loads, rust prevention, and transmission of loads to the foundation.

【Commentary】

This clause is specified by reference to sections 15.2, 15.3, 15.12, and 15.13 of Reference and Handbook for Highway Bridges [Japan Road Association, 2002] and Standards and Handbook for Designing Railway Structures - Steel/Composite Structures (SI unit version) [Railway Technical Research Institute, 2000]. Any part of the column base of a rigid frame structure that is under the ground or in water must be protected with reinforced concrete, corrosion resistant plating, corrosion resistant paint, etc.

In general, a rigid frame structure is designed on the premise that the column base is completely fixed or completely hinged. Hence, the quality of the anchor design has a great influence on the quality of the entire rigid frame structure. Since specific design methods are not provided in Reference and Handbook for Highway Bridges, individual design standards have been drawn up by each of the former public corporations that construct many rigid frame structures [Metropolitan Expressway Corporation, 2003, Hanshin Expressway Corporation, 2000, Nagoya Expressway Public Corporation, 2003, Fukuoka-Kitakyushu Expressway Corporation, 2002].

Regarding types of anchor structure, there are four basic designs as presented in Table C12.6.1: ① bearing plate, ② reinforced concrete, ③ direct fixing, and ④ piling. The type of structure adopted and details of verification differ among the former public corporations. In the case of Hanshin Expressway Co., Ltd. (the former Hanshin Expressway Corporation), though it has a long track record in the

construction of bearing plates of composite reinforced anchor frame type, it has been omitted because the design standards are under review. In Ultimate Strength and Design of Steel Structures (Japan Society of Civil Engineers, 1994), essential details for the design of reinforced concrete anchors for rigid frames are given along with proposals for implementing the limit state design method. Meanwhile, Study Report on Evaluation Method for Critical Strength of Structures (Japan Society of Civil Engineers, 2002) gives a method of evaluating the bearing force at the anchor and presents the results of a study of the method based on Reference and Handbook for Highway Bridges.

Table C12.6.1 Structural type of anchor part in each former public corporation

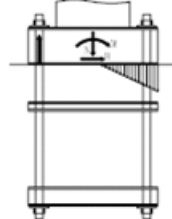
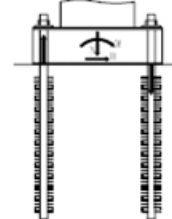
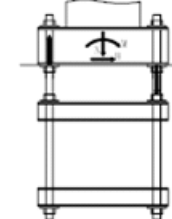
Former Public Corporation Name	Metropolitan Expressway Corporation	Hanshin Expressway Corporation	Nagoya Expressway Public Corporation	Fukuoka-Kitakyushu Expressway Public Corporation
Structure Type	Bearing plate type	Reinforced concrete type	Direct fixing type	Piling type
Schematic Diagram				
Design Concept	It resists compressive forces and tensile forces by anchor bolt and bearing plate.	It resists compressive forces by concrete under the base plate, and it resists tensile forces by anchor bolt and anchor frame (anchor beam).	It resists compressive forces and tensile forces only by anchor bolt which is also utilized as stud bolt.	It resists compressive forces and tensile forces by anchor bolt and anchor frame (anchor beam).
Remarks	It replaces the conventional anchor beam with a bearing plate. Design of the conventional anchor frame still exists in the design standards.	It has a track record of constructing a composite reinforced anchor frame type of a bearing plate, but the design standards are under review.	Design of the conventional anchor frame still exists in the design standards.	Design standards allow use of reinforced concrete type if it is expected to fill concrete under the base plate for construction. It also has a track record of test construction of direct fixing type.

Furthermore, in Standards for Designing Steel Structures [Architectural Institute of Japan, 1973] and Guidelines and Handbook for Designing Limit State of Steel Structures [Architectural Institute of Japan, 2002], there are provisions with respect to designing the column base. An outline of these follows.

- (1) Sections 17.1 and 17.2 of Standards for Designing Steel Structures [Architectural Institute of Japan, 1973] stipulate that the design must be in accordance with the following (Fig.C12.6.1).

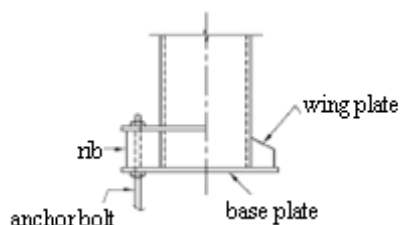

Fig.C12.6.1 Anchor part

- a) If the column base is assumed to be fixed:
- 1) Wing plates and ribs should be used to prevent deformation of the base plate. In addition, joints with the main column member should be completed or combined with the foundation

by coating with reinforced concrete.

- 2) The bottom surface of the base plate and the upper surface of the foundation must be firmly connected. In this case, the area of the base plate and the sectional area of the anchor bolts may be calculated by regarding the structure as a reinforced concrete column with a cross section that takes the form of the base plate and with reinforcement consisting of the tensile anchor bolts. The thickness of the base plate can be calculated by assuming that the additional reactive forces acting on the base plate will be added to the rectangular plate divided by stiffeners.
 - 3) If the shear force at the column base is assumed to be transmitted via the frictional force between the bottom surface of the base plate and the concrete, the friction factor should be set at 0.4.
 - b) If the column base is assumed to be a pin and is subject to a tensile force, anchor bolts must carry the shear force of the column base and a combination of the tensile force and the shear force must be considered.
- (2) In Guidelines and Handbook for Designing Limit State of Steel Structures [Architectural Institute of Japan, 2002], column bases are classified into three types: ① exposed column, ② reinforced column, and ③ embedded column. For design, it is also stipulated that, by considering structural division of the designed structure framework, the overall plastic bearing force or the yield bearing force must exceed the bearing forces in the ultimate limit state and in the service limit state.

12.7 Considerations of Torsion Acting on Steel Towers

Power transmission towers and columns are subject to torsional loads due to non-uniform tension in the cables. In this case, the sectional forces shall be calculated and the safety of the structure verified.

【Commentary】

While this chapter can be used in the design of truss-type power transmission towers and steel columns, as shown in Fig.C12.7.1, attention should be paid to situations in which one or more of the suspended cables is severed by a phenomenon such as snowfall or wind, causing the steel tower or steel column to be subject to non-uniform tension. This provision is made in accordance with Explanation 33 in section 3.1 of [Institute of Electrical Engineers of Japan, 1979]. In general, the calculation of these

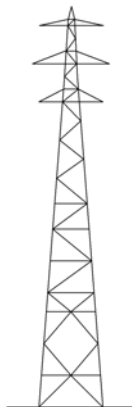

Fig.C12.7.1 Power transmission tower

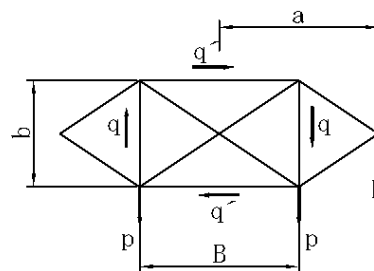

Fig.C12.7.2 Cross section of a steel tower/column

torsional forces (torsional moment) is very complicated because they are represented by a high-order indeterminate equation; however, stress may be calculated using the following simplified equations.

$$\left. \begin{aligned} p &= \frac{P}{2} \\ q' &= \frac{ba}{B^2 + b^2}P \\ q &= \frac{Ba}{B^2 + b^2}P \end{aligned} \right\} \quad (\text{C12.7.1})$$

As shown in Fig.C12.7.2, by dividing the non-uniform tension P into two forces p in the same direction and torsion consisting of a combination of q and q' , the stress of each member can be calculated based on the individual horizontal forces.

References in Chapter 12

- Architectural Institute of Japan (1973) : Design Code for Steel Structure.
- Institute of Electrical Engineers of Japan (1979) : Standards for Designing Supporting Objects for Electric Transmission .
- Architectural Institute of Japan (1980) : Guidelines and Handbook for Designing Tower-shaped Steel Structures .
- Japan Road Association (1980) : Specifications for Highway Bridges and Commentary.
- Fumio Nishino, Chitoshi Miki, and Atsushi Suzuki (1981) : Bridge and fundamentals, background and practice for revising reference and handbook for highway II, Chapter 13 Rigid frame structure .
- Japan Society of Civil Engineers (1997) : Design Code for Steel Structures, PART A; Structures in General, PART B; Composite Structures.
- Japan Society of Civil Engineers (1994) : Ultimate Strength and Design of Steel Structures, Steel Structure Series 6 .
- Railway Technical Research Institute(2000) : Design Standards for Railway Structures and Commentary, Steel and Composite Structures .
- Hanshin Expressway Corporation (2000) : Design Standards, Part 2, Standards for Designing Structure (Bridges) .
- Japan Society of Civil Engineers (2002) : Study Report on Evaluation Method for Critical Strength of Structure .
- Architectural Institute of Japan (2002) : Guidelines and Handbook for Designing Limit State of Steel Structure (SI Unit Version) .
- Japan Road Association (2002) : Specifications for Highway Bridges and Commentary, I Common Specifications Volume, II Steel Highway Bridges Volume.
- Fukuoka-Kitakyushu Expressway Corporation (2002) : Design Standards, Part 2, Standards for Designing Structure (Bridges) .
- Metropolitan Expressway Corporation (2003) : Recommendations for Design of Bridge Structures of Metropolitan Expressway Bridges .
- Nagoya Expressway Public Corporation (2003) : Standards for Designing Steel Structure .
- Japan Society of Civil Engineers (2005) : Guidelines for Designing against Buckling, Second Revision (Version 2005) .

Chapter 13 Plate Structures

13.1 General

- (1) This chapter applies to the design of plate structures. Plate elements and stiffened plate elements should be designed according to Chapters 6 and 10. A structure that can be considered a frame structure shall be designed according to Chapter 12.
- (2) The structural analysis of special structures to which this chapter does not apply shall be carried out under rational loading and support conditions.
- (3) Structural details and both of loading and support conditions for structural analysis should be followed design engineer.

【Commentary】

Most steel structures consist of plate elements. This chapter is applicable to steel structures for which buckling behavior is a significant determinant of performance.

- (1) (1) The structural characteristics of plate structures, as covered in this chapter, can be seen as aggregates of flat plate elements with clear static performance, such as steel girders, steel deck plates, steel piers, and so on. Therefore, this chapter is applicable to the following structures consisting of plate elements:
 - steel deck plate,
 - steel girder subjected to the bending moment,
 - beam-to-column section of rigid frame structure,
 - sections under concentrated loading, such as diaphragms or panel points of truss members, and so on.

The design of plate elements under compression, however, should follow the prescriptions given in section 6.3.1. In cases where the local deformation of the elements is small and the characteristics of structure as a whole can be understood as those of a rigid frame member, the design of the structure is outside the scope of this chapter and should follow section 10.3.1.

These provisions may be applied correspondingly to members such as curved plate elements, including the web plate of a curved girder or a corrugated steel plate, by replacing the curved plate element with an equivalent element. Structural analysis for structural design of the plate structure should be carried out with a suitable numerical model that simulates the static role of each element.

A steel deck plate, which is an example of a plate structure subjected to out-of-plane loading, the distributed load acts directly on the deck plate, while rib plates work with nearby parts of the deck plate to transmit the forces to the steel girder or beam. In this situation, the components of stress for the steel deck plate can be estimated using plate bending theory while those for the rib plates can be estimated using beam theory with effective width.

- (2) When structural analysis of a plate structure is carried out using plate theory, a rational approach should be applied with attention paid both to loading and support conditions. Typical considerations are stress in the plate element, local stress concentrations, and elastic buckling stress. Because of the simple shape of a plate element these can be obtained from the chart where both the displacement and force boundary conditions are clear. However, in other cases where the stress of a non-standard plate structure is estimated by a numerical analysis method such as

the finite element method, the finite elements should be set up using a mesh arrangement that does not result in reduced precision. Furthermore, the following requirements must be met:

- 1) The loading system to which a plate element is subjected can be divided into the direct load on the plate and the transmitted load that takes the form of stress at the boundary of the plate. It is necessary to carry out numerical analysis using a structural system that includes structural members with clear loading conditions or, if the load factor and distribution of loading are not clear, that sets the most disadvantageous loading conditions for each element.
- 2) Where a partial structural model is extracted from the whole structure, it is necessary to apply reasonable support conditions. Using spring supports is recommended as a way to model imperfect boundary supports. However, if the spring constant is uncertain, the most disadvantageous boundary condition should be set by the spring constant in numerical analysis.
- 3) Given that the responsible engineer has the authority to find that global load capacity is not influenced by local stress concentrations nor by local buckling of each element, this decision could compromise the safety level of the whole structure. Careful attention is necessary to the initial deformation and residual stress because they may reduce the strength of the plate structure.

13.2 Effective Width

The stress and the flexural stiffness of girders and beams subjected to the bending moment shall be calculated with considering the influence of the shear lag by using effective width.

【Commentary】

The longitudinal stress acting on the flange plate of a ribbed steel girder or a steel deck plate has an uneven distribution in the transverse direction if a bending moment is acting the girder or deck. This phenomenon is known as shear lag. Complex calculations of displacement and girder stress are required to model shear lag. Therefore, effective width and constant effective stress can be defined corresponding to uneven longitudinal stress, and flexural resistance and maximum stress should be estimated by using the above effective width and the effective stress.

Japan Specifications for Highway Bridges (II Steel Bridges) [Japan Road Association, 2002a] regulate the effective width in section 8.4.4 and section 10.3.5, while Design Standard for Railway Structures (Composite Steel Structures) [General Railway Technology Institute, 2000] follows the these specifications.

13.3 Steel Girder Web

The post-buckling strength can be expected in the steel girder web which is subjected to both of in-plane bending and shear loadings. The influence of welding distortion, stress in the manufacture, transportation and construction should be considered in the design of the steel girder web.

【Commentary】

Refer to [Japan Road Association, 2002a and General Railway Technology Institute, 2000] for stiffening of the web plates of a steel girder.

One solution for reducing the cost of public works is to shift the general concept of construction

work from minimum process to minimum weight. This can lead to greater web thickness as the number of horizontal and vertical stiffeners is reduced. The aspect ratio is limited to less than 1.5 in [Japan Road Association, 2002a], but experimental results have shown that the aspect ratio can be extended up to 3.0 [Ogaki, 1998][Nara, 1997]. Japan Highway Corporation has adopted a design code that allows reduction in the number of vertical stiffeners for the web plate of a continuous composite 2-main girder bridge with a pre-stressed concrete slab. Over 30 bridges have been constructed according to this code in the past 10 years. However, the code requires that the following conditions should be satisfied:

- shear stress can be evaluated small and positive bending moment are affected,
- stress gradient of bottom flange can be calculate less than -1.2, and so on.

13.4 Plate Structure Subjected to Out-Plane Loading or Combined Out-Plane and In-Plane Loadings

- (1) In case of stiffening of steel plate subjected to out-plane loading, the arrangement and the stiffness of stiffeners should be defined as both the deflection and the stress not to exceed the limit value, and verified the safety for load performance of the stiffeners themselves.
- (2) In case of stiffening of steel plate subjected to combine out-plane and in-plane loadings, the safety for load performance of the stiffened plate shall be verified against each loading and both loadings.

【 Commentary 】

Where a steel plate subjected to out-of-plane loading is to be stiffened, it is common to determine the spacing, location, and stiffness of the stiffeners so as to ensure the safety of the plate element. Furthermore, the safety of the stiffeners should be verified, since they may be affected by bending moment or shear force from the steel plate.

The limit state of the steel plate should be verified in consideration of both stresses that is related to plate bending and that is related girder behavior with effective width and their stiffener. However, evaluation of plate bending stress should be entrusted to the responsible engineer.

13.5 Other Plate Structures

The rectangle plate structure with uniform shape and thickness should be designed by chapter 6. The plate structures other than the above-mentioned shall be designed with paying many attentions to their mechanical characteristics.

【 Commentary 】

Corrugated steel plates and longitudinally profiled steel plates (LP plates) are examples of rectangular plate element with varying shape or thickness. Corrugated steel plate is used to form the web plate of pre-stressed concrete bridges in expectation that its geometry will have an effect on improving shear buckling resistance. A simple estimating method for the load capacity of the corrugated steel web of a steel-concrete composite girder is proposed in [Taniguchi et al., 2003 and Kato et al., 2002].

A method of estimating the buckling strength of LP plate, which follows the method of evaluating the buckling strength of a plate of uniform thickness by taking into account the equivalent thickness, is proposed in [Murakami et al., 1997 and Hotta et al., 1997].

13.6 Load Concentrate Point

The load concentrate point, such as the supports, shall be designed with verifying the safety against concentrate loading.

【Commentary】

The safety of points of load concentration, such as supports and attachments between a girder and ribs or braces, should be ensured by means of vertical stiffeners, diaphragms, or similar. In the design of load concentration points, refer to the following design codes: [Japan Road Association, 2002a, Japanese Society of Civil Engineers, 1994, and Metropolitan Highway Corporation, 2003].

Details of connections between superstructure and isolating supports should be designed such that the reaction force due to the dead load and the live load is transmitted smoothly to the bearing support. Furthermore, an isolating support should be able to transmit the inertial force of the superstructure to the bearing support during earthquakes and should be designed such that no local deformation occurs. An isolating support consists of the girder web, vertical stiffeners and diaphragms on the support itself, ribs, and other components. The design of the vertical stiffeners and diaphragms for the support is carried out as for a steel bearing support. Ribs should be designed such that the bearing stress is distributed equally, while the stress due to rotational displacement of the superstructure should also be distributed uniformly. Vertical stiffeners on the support should be extended until the edge of a rubber bearing to ensure that stress is properly transmitted because the plane geometry of a rubber bearing is larger than that of a steel bearing.

13.7 Beam-to-Column Connection

At the beam-to-column connection, the stress between the beam members and the column members shall be smoothly transmitted. In addition, the beam-to-column connection shall be designed with paying many attentions to the stress concentration in local area.

【Commentary】

For the design of a beam-to-column connection without a haunch or with a linear or circular haunch, refer to [Japan Highway Corporation, 1998, Metropolitan Highway corporation, 2003, and Nagoya Highway Corporation, 2003]. On the other hand, beam-to-column connections with other geometries can be designed by finite element analysis or following the three design codes referenced.

In recent years, fatigue failures in the beam-to-column connections of steel rigid frame piers have been reported [Miki et al., 2003]. In order to avoid fatigue failure, sufficient attention must be paid to welding in the design, manufacture, and construction of beam-to-column connections. [Metropolitan Highway Corporation, 2003] recommends beam-to-column connections with fillets.

13.8 Panel Connection

Panel connection should be a simple structure as much as possible to smoothly transmit membrane forces each other. In addition, structural details of panel connection should be considered to be easy connect of each member, to enable easy maintenance work, such as inspection, drain, cleaning and so on.

【Commentary】

For the panel connections of a truss structure, provisions for the thickness of the gusset plate are given in [Japan Road Association, 2002a, Institute of Railway Technology, 2000, and Japan Society of Civil Engineers, 1976]. Where the panel connection is particularly affected by high loading or secondary stress, refer to [Japan Society of Civil Engineers, 1976].

When connecting a suspension member or the supporting column of an arch structure with a stiffened girder or arch rib, it must be ensured that no defects arise as a result of stress concentrations and secondary stress in the panel connection. [Japan Bridge Association, 2002] gives some information about the structural details of such panel connections. Where a tubular member is used for the connection, refer to section 10.5.

13.9 Cross Beam, Cross Frame, Lateral Bracing and Diaphragms

13.9.1 General

- (1) Structural details of steel girder should be able to maintain the shape and the stiffness of the structure, to transmit lateral loading to the support.
- (2) Details of load concentration point of steel girder and truss structure should be able to maintain the shape and transmit concentration load.
- (3) Geometrical properties of cross-frame and lateral bracing should be considered both of the structural rigidity and the construction.
- (4) All the followings are satisfied, slenderness parameter of the member can be applied the criterion in chapter 10,
 - bridge structure is considered as a plane structure that pays attention to main girder or main structure,
 - cross-frame or lateral bracing without performing as a principal member,
 - cross-frame or lateral bracing is installed as a truss member.

【Commentary】

- (1) Cross-beams, cross frames, lateral braces, and diaphragms are member that help maintain sectional form, ensure stiffness, transmit lateral loadings smoothly to the supports, and help satisfy the spatial functions of a structure. This article prescribes that such members should, in principle, be fitted to steel girders, such as in [Japan Road Association, 2002a and Institute of Railway Technology, 2000].

In the case of a bridge with two narrow I-shaped girders, it is necessary to pay careful attention to global lateral buckling of the whole structure when the number of lateral braces is reduced. [Japan Road Association, 2002a] prescribes the following requirements with regard to this type of failure:

- 1) The safety against lateral buckling of a two main girder bridge should be verified in the case that the moment of inertia with respect to the horizontal axis is less than that with respect to the vertical axis and the ratio of span to web interval exceeds 18.0.
- 2) The torsional stiffness of a curved girder should be increased by way of installing lateral bracing.

In recent years, it has become possible to reduce the number of lateral braces, cross beams, and cross frames or simplify them for the purpose of structural simplification. When this is done, the structural system must complement the function of the lateral braces and cross frames in order to ensure resistance to lateral loading of the steel girder and the stability of the whole structure.

- (2) Where eccentric loading affects a box-girder or where wheel loading directly affects the flange plate, [Railway Technology Research Institute, 2000] requires that diaphragms have sufficient stiffness against shear buckling and prescribes detailing in accordance with [Japan Road Association, 2002a].
- (3) Since the stress affecting cross frames and lateral braces is small, their cross-section is dominated by the slenderness ratio. However, the minimum size of L-angles is regulated in principal to avoid the installation of narrow members as cross frames and lateral braces from the viewpoint of stability.

13.9.2 Cross beam

In case that the slab is supported with several main girders, the cross beam on support or the cross beam for load distribution should be installed between each main girder.

【Commentary】

[Japan Road Association, 2002a] recommends that cross beams for load distribution should be installed at intervals that do not exceed 20 m so as not to violate the assumptions made in the design of the concrete slab if the span of each girder exceeds 10 m. These cross beams for load distribution should have sufficient stiffness to overcome the influence of relative deflection between each girder and the concrete slab.

Filled cross beams are recommended for curved girders. Connections between the main girder and the cross beams should be designed in consideration of the load transmission mechanism.

13.9.3 Cross frame

- (1) At the support of deck bridge, the end cross-frame should be installed between each main girder or each main structure.
- (2) The cross-frame which takes charge of load distribution should be designed as the principal member.
- (3) The cross-frame of the skew bridge should be placed with paying attention to the analytical procedure, production and construction process.
- (4) All the followings are satisfied, cross-frame can be reduced,
 - structural rigidity is ensured as whole structure such as reduced main girder bridge,
 - responsibility design engineer verify the structural safety.

【Commentary】

Since reaction forces arise if a member is damaged or if there is uncertainty about a member, cross beams should be installed between each girder of an upper deck bridge.

13.9.4 Lateral bracing

- (1) Structural details of steel girder should be able to transmit lateral loading to the support.
- (2) All the followings are satisfied, upper lateral bracing can be reduced,
 - bridge type is the deck bridge,
 - the orthotropic deck or concrete slab is connected with main girder,
 - horizontal motion of main girder is restrained.

【Commentary】

- (1) In order to ensure the stiffness of the main girder, [Japan Road Association, 2002a] requires that lateral bracing is installed at the top and bottom of the main girder.
- (2) Lateral bracing can be omitted in a case where the floor system and the main girder are connected tightly to each other with a concrete slab or steel deck plate. However, lateral bracing may also help prevent deformation of the structure during construction so it may be better not omit the lateral bracing depending on the erection method. [Japan Road Association, 2002a] allows the bottom lateral bracing to be omitted as long as the span is less than 25mm and strong cross framing is installed. Omitting the lateral bracing in a curved girder may lead to a decrease in the torsion resistance of the whole structure, so [Japan Road Association, 2002a] prescribes that lateral girders must be present in the case of a curved girder.

13.9.5 Diaphragms

- (1) Diaphragm should be placed as followings in standard,
 - an angle of skew direction in the supporting part of the skew girder bridge,
 - a right angle to main girder in the intermediate part of the skew girder bridge,
 - a normal direction to main girder in the curved girder bridge.
- (2) An opening, or a manhole, should be installed in the diaphragm if necessary.

【Commentary】

- (1) Generally, a diaphragm should be installed at a right angle to the main girder, except in the case of a skew bridge; this increases the stiffness of the diaphragm itself and simplifies manufacture. A few examples of provisions relating to diaphragm spacing are given below:
 - [Metropolitan Highway Corporation, 2003]: intervals of about 6m are recommended,
 - [Japan Highway Corporation, 2000]: interval not to exceed 6m,
 - [Nagoya Highway Corporation, 2003]: spandrel-filled diaphragms can be installed at intervals of less than 6m; sub-diaphragms are required if the interval is over 6m.
- (2) [Japan Road Association, 1980] proposed characteristic values of stiffness parameter, K , according to the shape of the opening and the opening ratio, ρ , as follows:
 - $\rho \leq 0.4$: filled spandrel type,
 - $\rho \geq 0.8$: rigid frame type,
 - other : cross frame type.

References in Chapter 13

- JSCE (1976) : Research Report on the Honshu-Shikoku Connecting Bridge Superstructure Steel.
- Japan Road Association (1980) : Manual on Steel Bridge Design
- Japan Society of Civil Engineers (1994) : Ultimate Strength and Design of Steel Structures, Steel Structure Series 6 .
- Nara Takashi, Ogura Tsutomu (1995) : Shear strength and vertical stiffener of the steel girder web plate panel, Japanese Society of Steel Construction, Structural Steel Collection Annual Report Volume 3 dissertation.
- Tada Hiroyuki (1996) : Design and construction of bridge deck pavement.
- Japan Society of Civil Engineers (1997) : Design Code for Steel Structures, PART A; Structures in General.
- Nara Takashi, Ogura Tsutomu (1997) : Evaluation of ultimate shear strength of web plate panel considering the vertical stiffener, J. Steel Constr. Eng., JSSC, Vol.5.
- Hotta Takashi, Nishimura Nobuo, Murakami Shigeyuki, Taki Hideaki (1997) : Using the design method TEPA-PURETO I digit local buckling of the section, the paper's annual steel structure Album Report, Vol.5, pp.239-246.
- Murakami Shigeyuki, Nishimura Nobuo, T. Horita (1997) : TEPA-PURETO compressive strength of the prominent freedom, Journal of Structural Engineering, Vol.43A, pp.107-116.

- Japan Highway Public Corporation (1998) : Design Guide Vol.2.
- Kazuo Ogaki, Hee Kawaguti, Isoe Akira, Takahashi Akikazu, Kawashiri Katsutoshi, Nagai Masatugudashi (1998) : Two real synthesis for design of stiffened steel main girder bridge main girder Research experience, Journal of Structural Engineering, Vol.44A, pp.1229-1239.
- Railway Technical Research Institute(2000) : Design Standards for Railway Structures and Commentary, Steel and Composite structures .
- JSCE (2002) : Report of international standards for structural steel research and analysis.
- Japan Road Association (2002a) : Specifications for Highway Bridges and Commentary, II Steel Highway Bridges Volume.
- Japan Road Association (2002b) : Fatigue Design Guideline for Steel Highway Bridges .
- Japan Highway Public Corporation (Japan) Expressway Technology Center) (2002) : PC floor slab two continuous composite steel beam bridge design and construction documentation.
- Katou Hisato, Takashi Kawabata Atsushi, Nishimura Nobuo (2002) : Practical use of force and displacement of the bridge cross-section steel-concrete composite structure with a corrugated steel web Calculus, Journal of the Japan Society of Civil Engineers, No.703/I-59, pp.293-300.
- Metropolitan Expressway Public Corporation (2003) : Design Guide for Highway Bridge Structures Capital.
- Nagoya Expressway Public Corporation (2003) : Design Guide for Steel Structures.
- Yoda Teruhiko Tanikuti Nozomi (2003) : Study of simple bending analysis of composite girder with corrugated steel web, Journal of the Japan Society of Civil Engineers, No.577/I-41, pp.107-120.
- Miki Tizu, Akira Hiroshi Hirabayashi, Tokita Hideo Hiroshi Konishi Taku, Yaginuma Toshiyasu (2003) : Fatigue cleavage mode of the plate pair configuration and angle of the steel pier, construction of Journal of the Association, No.745/I-65, pp.105-119.
- DASt-Richtlinie 012 (1978) : Deutscher Ausschuss for Stahlbau.
- AASHTO (2003) : AASHTO LRFD Bridge Design Specifications- S.I. Units 2003 Interim Revisions.
- CEN (2003a) : prEN 1993-1-1 : Eurocode 3 : Design of Steel Structures, Part 1-1 : General Rules and Rules for Buildings, Stage 49 draft.
- CEN (2003b) : prEN 1993-2 : Eurocode 3 : Design of Steel Structures, Part 2 : Steel Bridges, Stage 34 draft.
- CEN (2003c) : prEN 1993-1-5 : Eurocode 3 : Design of Steel Structures, Part 1.5 : Plated Structural Elements, Stage 34 draft.

Chapter 14 Slab Design

14.1 General

14.1.1 Structural scope

This chapter applies mainly to designed slabs under out-of-plane actions.

【Commentary】

The slab of a road bridge is often subjected to out-of-plane loading through the pavement. Where this is the case, the effect of pavement rigidity on the out-of-plane rigidity of the slab should be disregarded because the physical properties of the pavement are significantly affected by temperature. It is generally accepted that the pavement has the effect of distributing this loading over the thickness of the slab. Further, the entry of water into a concrete slab may cause the strength of the slab to decrease under cyclic loading while steel members may corrode badly. For this reason, the surface of the slab should be protected with a waterproof layer.

14.1.2 Design action

The design actions as stipulated in Chapter 2 shall be considered in the design of a slab to cope with variable actions such as a live load.

【Commentary】

A slab is a member that directly supports the load and is subjected to variable actions, including live and impact loads. The effects of these variable actions should be fully taken into account in determining the actions on the slab used in design. Road and railway bridges are designed in accordance with the specifications [Japan Road Association, 2002a; Railway Technical Research Institute, 2000]. If actual loads different from design actions are expected, the effects of these actual loads need to be taken into account. Although the available reference data on variable actions acting on slabs is limited, the distribution of axle loads can be estimated from the assumed traffic volume and the ratio of large vehicles by consulting the literature (such as Technical Note No. 2700 of the Public Works Research Institute).

14.1.3 Analytical procedure

- (1) The analytical model shall be developed through the choice of an appropriate modeling range under appropriate boundary conditions.
- (2) In principle, the slab part shall be extracted as a board structure in the analysis. Depending on the purpose of the verification, the slab shall be modeled as having a large influence on the stress state at the verification point.
- (3) In modeling each structural member, an appropriate element shall be chosen in consideration of its structural characteristics.
- (4) The value of each material physical property shall be made an appropriate value reflecting its behavior.
- (5) The evaluation of the analytical results shall be based on the modeling conditions as appropriate.

【 Commentary 】

- (1) Although it is desirable to model the entire structure, it may be modeled in part as long as this has no effect on the stress state at a verification point. Taking the unidirectional slab of a straight steel bridge as an example, the full width of the slab and about twice the width of the slab need, as a rule, to be modeled in the transverse and longitudinal directions, respectively. For slabs other than unidirectional ones as well as the slabs of horizontally curved bridges and those with a significant longitudinal gradient, the extent of the model needs to be studied.

As regards the support conditions of a slab supported on steel I girders, the assumption can be made that the slab is simply supported at the location of the girder webs. For a slab supported on a box girder, the support conditions at the top face of the upper flange of the box girder should be modeled appropriately.

- (2) When using FEM analysis in design, the slab is essentially regarded as a plate structure and design member forces and deflections are calculated according to the rigidity and anisotropy of the slab, its span, the layout of girders, the skew angle, and other factors. For a concrete slab, only the concrete portion is modeled in general, while any steel plates, rebars, prestressing tendons, studs, and other components should be modeled as appropriate in consideration of their effects on the slab at the point of verification [Sakamoto et al., 2002; Honma et al., 2002]. Further, in modeling a pavement whose toughness falls in high-temperature environments, such as an asphalt pavement, only the slab's load distribution action is taken into account, while the flexural rigidity of the slab should be left out of consideration.

When the purpose of analysis is not to calculate design member forces or deflections but to calculate local stresses, to check the load bearing capacity, or to understand the vibration characteristics, cracking properties of concrete, thermal stresses of concrete, and prestressing forces introduced in a prestressed concrete (PC) slab, the recommendation is to model the structural members in addition to the slab as determined necessary after consulting past cases [Miki et al., 2005; Nagayama et al., 1998; Kawabata et al., 2004a; Japan Bridge Association, 2004; Yasumatsu et al., 2003].

- (3) The use of plate elements to check the overall behavior of a slab and calculate design member forces and deflections is an efficient method. However, when the anisotropy of the slab is very large or the degree of deterioration of a reinforced concrete (RC) slab is taken into account, it is recommended to use elements capable of taking into account the anisotropy [Matsui et al., 1995; Sato et al., 1998; Honma et al., 2002]. When taking into account the orthotropy of a steel slab, analysis using the finite strip method, which takes into consideration a dynamic model composed of strips and lateral ribs, is also effective [Tada, 1971]. In determining the distribution of stresses in the direction of thickness or calculating the local stresses in members inside the slab, it is recommended to use solid, plate, beam, and other elements in combination for modeling.

When solid elements are used for modeling, it is necessary to consider how the mesh is set in the direction of slab thickness or plate thickness so as to avoid shear locking. Further, in connecting elements having different degrees of freedom, it is necessary to deal appropriately with the degrees of freedom. When using higher-order elements, the effects of the characteristics of the elements on the results of the analysis need to be understood. And when taking into consideration steel girders in the modeling of the slab, the eccentricity caused by the thickness of the slab should be factored in.

- (4) In calculating the design member forces and deflections for road bridges, steel members are dealt with as linear elastic bodies using the physical properties specified in the Specifications for Highway Bridges (the Specifications) [Japan Road Association, 2002] or obtained as test results. Concrete members are assumed to be linear elastic bodies, with cracks neglected when the elastic deflections of girders under loading are not more than about $L/500$ ($L/300$ for cantilevers), using

the physical properties specified in the Specifications. In addition, when checking load-bearing capacity, the nonlinearity and cracking of concrete need to be taken into consideration, but appropriate modeling of these characteristics is a subject for future study. In carrying out the thermal stress analysis of slab concrete, the material nonlinearity specified in the Standard Specifications for Concrete Structures [JSCE, 2002a] is taken into consideration [Japan Bridge Association, 2004.] For steel and other non-concrete materials, the physical properties of the materials are clarified and the nonlinearity of the materials is taken into account as needed.

- (5) If the structure is modeled appropriately, the structural analysis factor, $\gamma=1.0$, for analysis results can be taken as 1.0, except for the case where assumptions in modeling are unclear or the analysis is nonlinear.

In evaluating the results of analysis, it should be borne in mind that the results may vary depending on the type, shape, and size of the finite elements used. The preferred shape of finite elements in the vicinity of a point of interest is a square or cube. As a guide, finite elements should be about 50 mm in size when calculating design member forces; element sizing needs to be studied separately when calculating local stresses. There are some cases where excessively large values are derived by analysis at interSections of plate elements, at points where nodes of elements with large different rigidities are shared, in elements directly below loads, and in elements in restrained sections. In these cases, analysis values of adjacent finite elements are used for evaluation. Further, adequate attention needs to be paid to the relationship between the assumed element coordinate system and the global coordinate system.

14.2 Safety

14.2.1 Safety of slab

- (1) The slab shall be able to carry the load safely and directly, transmitting it to the supports.
- (2) The slab shall be designed so as to secure safety with respect to the two performance items that follow.
 - ① Safety in carrying the load directly
 - ② Safety as the main structural member

【 Commentary 】

- (1) A slab is subject to cyclic loading in addition to the dead load. As one of the floor framing members, the slab must transmit these loads safely to the girders as well as supporting them. Particularly when a slab is subjected to large cyclic loads, it is necessary to confirm that it is sufficiently safe even toward the end of its design service life.
- (2) The safety of the slab, as the plate member that directly supports the loads, needs to be ensured for its particular conditions of shape and support. Adequate safety must be ensured at the supports of the slab as well as for the slab in general. Further, the safety of the slab should be confirmed as needed during its transportation and/or construction until full completion. If the slab and girders are integrated into the main structural members or if the slab is subjected to large loads, such as earthquake and wind loading, in the in-plane direction, adequate safety needs to be ensured under these conditions also.

14.2.2 Out-of-plane shear

- (1) Under out-of-plane shear, the slab shall be completely safe against punching shear at the loading point.

- (2) Under out-of-plane shear, the slab shall be safe against shear at the supports.
- (3) In the case of change of stress transmission mechanism, the safety of slab shall be considered under the influence of cyclic loading.

【 Commentary 】

- (1) The slab that bears the load directly is subjected to an out-of-plane punching shear force that acts directly below the load point. The safety of the slab under the action of this force is verified based on the assumption that the force is distributed at an angle of 45° from the point at which the load acts. In this case, the effect of any eccentricity or unevenness of the loading near the loads point, if any, needs to be taken into consideration. The Specifications prescribe a minimum slab thickness to assure adequate safety under these forces. The safety of concrete members can be verified in accordance with the Standard Specifications for Concrete Structures [JSCE, 2002a.]
- (2) A slab supporting out-of-plane loads is subjected to a large shear force in the vicinity of its supports. It should be verified that the slab is safe at the load point where the maximum shear force is induced. The magnitude of the shear force used for the verification of safety at the supports should be determined, as a general rule, through analysis or tests. The Specifications [Japan Road Association, 2002b] assure the safety of the slab at the supports of the slab under the action of this shear force by prescribing a minimum thickness for the slab and installing haunches at the supports.
- (3) There are cases where an irreversible change in the force transmission mechanism results from tensile stresses, such as when cracking occurs, in a concrete slab. In a case where the slab is subject to cyclic loading, its safety needs to be considered in consideration of the effect of such changes in the force transmission mechanism. In practical terms, anisotropy due to cracking should be taken into account in calculating member forces and concrete in the tensile stress area should be neglected in conducting verifications.

14.2.3 Out-of-plane bending

- (1) Under out-of-plane bending, the slab shall be completely safe against the appropriate calculated out-of-plane bending.
- (2) In the case of according to proposed out-of-plane bending equation, it shall be necessary to note the coverage, the analytical condition, and accuracy and to carry out an appropriate correction if necessary.

【 Commentary 】

- (1) A slab that supports out-of-plane loads needs have adequate safety against the out-of-plane bending moment. The out-of-plane bending moment is determined from analysis or tests by assuming the most disadvantageous loading condition at the point of interest and taking into account uneven settlement at the slab supports, as well as the effects of support conditions that affect the direction in which the out-of-plane bending moment is induced.
- (2) The Specifications [Japan Road Association, 2002b] prescribe an equation for the out-of-plane bending moment induced by the live load. This equation should be used with a clear understanding of the assumed loading conditions, the scope of application including the span of the slab, the support conditions of the slab, the presence/absence of anisotropy, the accuracy of the equation, and the safety factor in the equation.

14.2.4 In-plane forces

- (1) Under in-plane forces, the slab shall be safe with respect to functioning as part of the main structure. It shall also be safe against earthquake, wind, and temperature changes.
- (2) When under in-plane forces caused by deformation of the slab supporting girder, the safety of the slab shall be considered of its influence.

【 Commentary 】

- (1) In a composite structure consisting of a slab and girders and also in the case of a steel slab, there are additional forces as well as the out-of-plane load acting on the member because of its role as part of the main structure. The safety of the slab should be confirmed under these additional member forces as well as under the member forces arising because of its role as the floor framing that directly supports the load as well as combinations of the two. In combining the actions of the main structure and the floor framing, the safety factor can be set by taking into account of the circumstances under which combined member forces are induced. The Specifications evaluate the safety of the slab under combined member forces by increasing the allowable stress by 40%.
- (2) If the girder supporting the slab undergoes significant deformation, in-plane forces in addition to the in-plane bending moment may act on the slab. In this case, the slab needs to be designed to ensure its safety under these in-plane forces.

14.2.5 Safety verification of slab

The safety of the slab shall be verified in consideration of pre-determined factors. At minimum, the verification of slab safety should be evaluated as follows.

- (1) General Part
- (2) Overhanging part (Support point and Base of handrail)
- (3) Girder end
- (4) Opening

【 Commentary 】

In order to verify safety, a number of factors need to be determined in an appropriate manner. In particular, if there is concern that the slab thickness may be insufficient, a large safety factor needs to be adopted, because any construction errors, including errors in slab thickness, can have a large effect slab strength. The bending moment equation specified in the Specifications gives results with a 10~20% safety margin as compared with theoretical values in consideration of the effects of structural analysis and construction errors.

In addition to a general verification, slab safety should be verified in the areas specified in this section. Further, aside from the areas mentioned above, other areas requiring consideration are where the cross section changes, at construction joints, at anchorages for prestressing tendons, and at points where prestressing tendons deflect. In these locations, the strength of members and the slab support conditions change. As structurally weak points, they should be provided with adequate reinforcement.

14.3 Serviceability

14.3.1 Serviceability of slab

The serviceability of the slab shall be verified using three performance items as follows.

- (1) Deformation of slab

From the point of view of users, the slab shall perform without deformation so as to provide safety and comfort for pedestrians and traffic.

(2) Vibration of slab

The slab shall perform without improper vibration under cyclic loading.

(3) Drainage of slab

The slab shall drain quickly, without water pooling on the slab surface.

【 Commentary 】

- (1) The slab is used by vehicles and pedestrians crossing the bridge. To ensure safe and comfortable crossing of the bridge, the roadway surface needs to be maintained as a continuous and even pavement.

It is important, for drivers and pedestrians, that the road surface is free of irregularities and does not pool water. Irregularities and water pooling on a paved road surface are phenomena that arise because of the condition of the pavement or the waterproof layer. Compaction during construction and deformation of the slab under the pavement while the structure is in service have a great effect on the performance of the pavement and the waterproof layer. Accordingly, the slab needs should be rigid enough that concrete does not crack and impair constructability during paving work or cause failure of the waterproof layer.

- (2) The slab vibrates and causes noise as vehicles cross the bridge. Occasional noise does not pose any major problem but noise can sometimes have a major effect on residents near a bridge depending on its level. In particular, the slab needs to be rigid enough that low-frequency noise is not generated.
- (3) One of the factors that affects the serviceability of a bridge roadway is the drainage performance of the road surface. Rainwater falling on the road surface flows down the longitudinal and transverse slopes of the roadway and into storm drains. In recent years, high-functionality pavements with a porous surface layer have been used to reduce vehicle noise and rapidly drain water from the surface. When this type of surface is used, the base course comprises an impermeable bed that is supported directly on the slab. The performance of the pavement has a direct effect on drainage performance and the finished surface of the slab becomes an important factor. It is necessary to control the surface finish of the slab and the slab needs enough rigidity that harmful cracks do not form. Additionally, rainwater flowing into the storm drains need to flow smoothly into the storm drainage system.

To verify the serviceability of concrete parts of the structure, it is necessary to study cracking because if cracks develop to widths larger than the allowable size or chloride ion concentrations at the depth of the steel increase to the critical concentration or higher, steel corrosion will take place and reduce the durability of the structure. The consequent degradation in watertightness and outward appearance impairs the serviceability of the structure. Cracking has the effect of degrading the durability of concrete mainly by promoting corrosion of the steel; this is covered in Section 14.5 "Corrosion Resistance and Resistance to Material Deterioration."

14.3.2 Serviceability verification of slab

According to section 7.3 "Verification of Serviceability", the serviceability of a slab should be verified using the following performance items.

(1) Deformation of slab

Deflection under live load and condition of the slab surface shall be within limits.

(2) Vibration of slab

The slab shall not resonate at the frequency of passing trucks.

(3) Drainage of slab

The slab shall drain quickly without water pooling on the slab surface.

【Commentary】

- (1) The concrete slab of a road bridge is considered problem free in use if its deflection under live loading is not more than 1/2000 of the slab span. Further, the slab surface is regarded as being rigid enough to resist deformation if any cracks are no wider than the limit value set during the design phase and if cracking is controlled below the target control value during construction.
- (2) The physical measures used to assess vibration characteristics include deflection, natural frequency, and acceleration. In the design of the superstructure, a limit value is set on resonance frequency for footbridges and on deflection under live loading for road bridges. The Report on Research Study of Vibration Phenomena Specific to Slabs [JSCE, 2004a] presents the relationship between the span and natural frequency of RC and PC slabs for steel road bridges, as shown in Figs.C14.3.1 and C14.3.2, respectively. The results of this survey of vibration and low-frequency problems (Table C14.3.1) indicate a high likelihood of low-frequency damage occurring when the natural frequency of the slab is about 10 Hz. This results from the fact that 10 Hz corresponds approximately to the frequency of the unsprung weight of large trucks [Kawabata et al., 2004a].

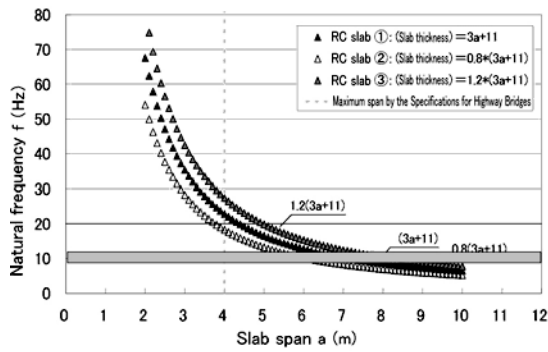

Fig.C14.3.1 Relationship between span and natural frequency of a slab (RC slab) [JSCE, 2004a]

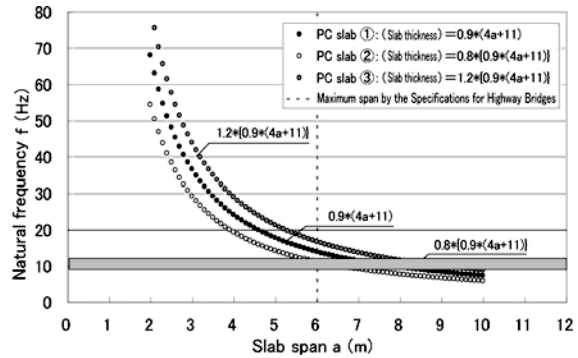

Fig.C14.3.2 Relationship between span and natural frequency of a slab (PC slab) [JSCE, 2004a]

Table C14.3.1 Results of survey of vibration and low-frequency problems [JSCE, 2004a]

Researchers	Results of survey
Yamada et al. [Noises and Vibrations 1978]	The frequency of the unsprung weight of large trucks is 8~20Hz.
Shimizu et al. [Noises and Vibrations 1982]	The dominant frequency of noise emitted from joints is 10~50Hz.
Yasuo Kajikawa [Prestressed Concrete 2003]	The dominant frequency of body sensory vibrations is about 14.5 Hz.
Itsuo Murai [Noise Control 1982]	The dominant frequency of noise emitted from the joints of elevated bridges is 10~30Hz.
Uchida et al. [Nagano research Institute for Health and Pollution Report 1979]	The peak appears at 12.5Hz.
Ishii et al. [Chiba Prefectural Research Institute for Environmental Pollution Report 1981]	The peak appears at 12 Hz.
Shozo Yamaga [Japan Highway Public Corporation Research Institute Report 1977]	Truss bridges: The peak appears at 10~14Hz. Steel girder bridges: The peak appears at 10-18 Hz.

- (3) The slab of a road bridge is regarded as satisfying the drainage performance requirement if the drainage system is constructed in accordance with the Road Earthworks: Guidelines for Drainage Works [Japan Road Association, 1987].

14.4 Fatigue Resistance

14.4.1 Fatigue resistance of slab

- (1) The slab fatigue resistance under cyclic loading (live load and wind load) shall be assured for the whole of the design working life.
- (2) The verification of slab fatigue resistance shall clarify the failure mechanism and examine the respective influence of out-of-plane shear and out-of-plane bending.
- (3) The verification of slab fatigue resistance shall be based on the appropriate specifications for fatigue strength.

【 Commentary 】

This section covers slabs of concrete construction, including RC, PC, and steel-concrete composite slabs.

- (1) The fatigue resistance of the slab refers to the resistance of the slab to fatigue failure when cyclic loads (live or others) above a certain level act on it. The most important action that influences the performance of a road bridge slab is the wheel loading. Wheel loading acts directly on the slab and the slab is subject to very severe conditions as a result of this repeated action. The requirements for fatigue resistance are that, under repeated wheel loading, the slab retains the safety factor set for each limit state during the design phase over the design service life and that the slab does not suffer damage that results in the safety or serviceability of the slab falling below the allowable level. There are few cases where fatigue other than that caused by moving vehicles presents a problem with the slab. However, if large sound absorbing barriers are fitted to the concrete barrier parapets, cantilevered sections of the slab may be subject to relatively large action caused by wind loading and this may cause specific vibrations. In this case, it is necessary to study the fatigue resistance of the slab under cyclic wind loading, depending on the magnitude of the stresses induced in the slab, as well as under other specific vibrations during the design service life of the slab. That is, the resistance of the slab to all cyclic actions, not only wind loading and vibration, needs to be ensured.
- (2) The mechanism of fatigue failure varies with the type of slab, so it is important to clarify the mechanism in the fatigue design of the slab. Once the failure mechanism has been clarified, it is possible to determine the fatigue strength as well as verify the fatigue resistance of the slab under cyclic loading over the design service life. An RC slab subjected to cyclic loading during the design service period needs to be resistant to fatigue caused by the flexural stress induced in the rebars and the slab concrete (flexural fatigue durability), by the shear force induced in the cross section of the slab (shear fatigue durability), and by the punching shear force induced in the cross section of the slab (punching shear fatigue durability). For a PC slab, the resistance of prestressing tendons and anchorages to fatigue, in addition to the fatigue resistance required of the RC slab, needs to be ensured. In the case of a steel-concrete composite slab, the fatigue resistance of steel members, such as bottom steel plates, frame members, and rebars, concrete members, and the joints between steel and concrete members need to be verified.
- (3) In the evaluation of fatigue strength, it is important to clarify the intensity of loads acting on the slab and the frequency of loading, and to use an appropriate evaluation method. To set

values for the cyclic action of traffic loading, an assumption needs to be made as to the traffic to be carried over the design service life of the slab. To be more precise, the magnitude and cumulative frequency distribution of the wheel loading need to be set. Although it is extremely difficult to correctly assess the cumulative sum of cyclic action imposed by wheel loading because vehicular traffic patterns vary with the social situation and the development of surrounding roads, it is necessary to set this cumulative sum by predicting, as accurately as possible, future traffic volumes based on measured traffic on in-service roads similar to that carried by the bridge [Bridge Research Laboratory, Department of Structures and Bridges, Public Works Research Institute, Ministry of Construction, 1988; Pavement Research Laboratory, Department of Roads, Public Works Research Institute, Ministry of Construction, 1995; Miki et al., 1985; Mori et al., 1995].

The following methods of evaluation the cumulative sum are proposed: evaluation of fatigue strength based on the S-N curve determined from the results of a moving wheel load test; a method based on the relative fatigue strength; and a method based on the equivalent load and fatigue safety factor. Further, in a case where the effects of other cyclic actions such as wind loading might be expected, the magnitude and cumulative frequency distribution of such actions need to be set and appropriately evaluated to determine the cumulative sum of the actions during the design service life of the slab. Incidentally, concrete slabs are currently regarded as satisfying the predetermined level of safety if they meets the provisions of the Specifications because it is known that their fatigue strength is significantly improved as compared with conventional concrete slabs.

Slab fatigue also includes out-of-plane flexural and shear fatigue and out-of-plane punching shear fatigue. In the case of flexural fatigue in a steel-concrete composite slab, it is generally the case that the steel fails in fatigue. In the case of the punching shear fatigue of a composite slab under live loading, it is the concrete that fails in fatigue, as in the fatigue failure pattern of RC slabs used for existing multiple girder bridges. To verify the resistance of the slab to fatigue, appropriate tests and analysis techniques capable of reproducing the failure mechanism of the slab should be used.

14.4.2 Fatigue due to out-of-plane shear

- (1) The slab shall exhibit durability against out-of-plane punching shear fatigue caused by wheel loading.
- (2) The slab shall exhibit durability against out-of-plane shear fatigue around it's the supports.

【 Commentary 】

- (1) The slab that directly bears the load is subjected to an out-of-plane punching shear force that act directly below the load point. The slab may fail in fatigue under these punching shear forces. As a method of evaluating the resistance of the slab to fatigue under punching shear forces, a fatigue test using a wheel-loading test machine is available. This is a method of testing the slab by driving a steel wheel or a rubber tire simulating the wheel of a vehicle over the slab such that it exerts the wheel load on the slab. It has been verified that the fatigue failure of RS slabs used in actual bridges can be reproduced by this test.

Various investigations have been carried out on punching shear failure after an RC slab has cracked transversely into multiple beam-like forms, and S-N curves based on the results of a moving wheel load test have been proposed [Matsui, 1987; Matsui, 1991; Yasumatsu et al., 1998]. However, the proposed S-N curves are represented by a single logarithmic function with an extremely gentle gradient ($m=1/11$ to $4/11$). Variations in materials and construction work as well as variations in the intensity of loading due to differences in loading patterns are extremely large

as compared with a change in the number of cycles of loading, N , on the time axis. Accordingly, it is difficult to judge the resistance of the slab to fatigue using the concept of the fatigue safety factor over the service life as compared with using the design service life.

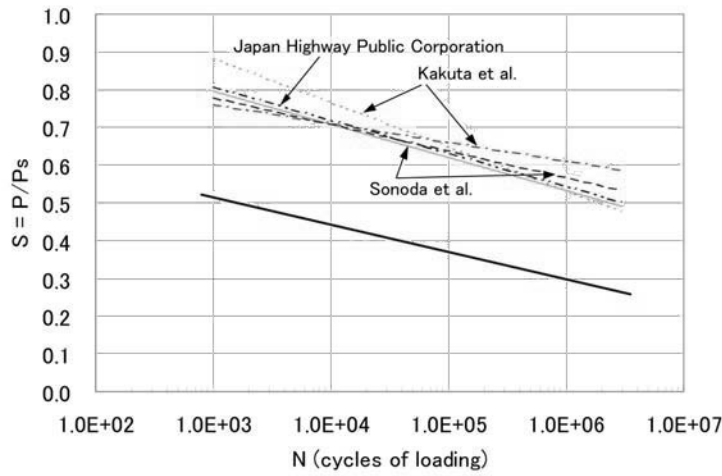

Fig.C14.4.1 Typical S-N curve (Osaka University) [JSCE, 2004b]

$$S = \frac{P}{P_s} = -0.07166 \log N + 0.7292 \tag{C 14.4.1}$$

To avoid this, a proposition is made to express the assumed loads during the required design service life in the form of representative load and the number of cycles and define the safety factor for the resistance of the concrete slab to fatigue as the ratio of the failure load on the S-N curve to the representative load [Kawabata et al. 2004b.]

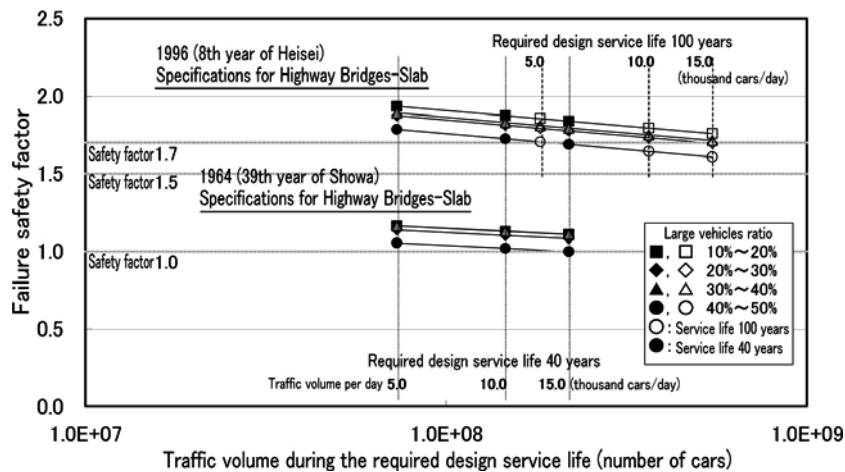

Fig.C14.4.2 Typical evaluation of fatigue durability by safety factor [Kawabata et al. 2004b]

$$P = \left(1 - \frac{\log N_{eff}}{14} \right) \frac{V_{pcd}}{k} \tag{C 14.4.2}$$

$$\nu = \frac{P}{P_{max}} \tag{C 14.4.3}$$

where , N_{eff} : equivalent number of cycles that is converted in such a manner that the fatigue damage from the maximum wheel load, P_{max} , becomes equivalent

- V_{pcd} : design punching shear capacity
 k : $= (2a + b)/(a + b)$ factor for the surface on which wheel load acts
 a : width of the surface on which the load acts,
 b : length of the surface on which the load acts

- (2) Attention should also be given to the shear fatigue failure in the vicinity of the supports of the slab on which the reaction of the loads acting on the slab acts, in addition to the parts on which the wheel loads directly act.

14.4.3 Fatigue due to out-of-plane bending

- (1) The slab shall exhibit durability against out-of-plane bending.
- (2) Slab connection components shall exhibit durability against stress caused by out-of-plane bending.

【Commentary】

- (1) The slab subjected to out-of-plane loads should be safe against the fatigue caused by out-of-plane bending moment. The most common failure pattern in the case of concrete slabs is punching shear fatigue. For PC slabs, there has been no report on the fatigue failure of the slabs with their slab thicknesses increased by the large span of the slabs. It is presumed that the fatigue failure of rebars or prestressing tendons due to bending rather than the punching shear failure is dominant [Yasumatsu et al. 1998; Hase et al. 1999; Honma et al. 1999.] The same goes for steel-concrete composite slabs.

The wheel-loading test that is conducted as a method of confirming the resistance of the slab to fatigue in some cases exerts a smaller bending moment on the slab than occurs in an actual bridge, primarily due to the limited size of the specimen (the short span of the slab). The flexural fatigue durability of the slab should be verified by an appropriate method, such as a fatigue test in which a load acts at a fixed point on a beam-shaped specimen simulating the cross section in the longitudinal or transverse direction of the bridge.

- (2) Members used to connect the components of a slab include shear connectors, which hold the concrete to the steel plate in a steel-concrete composite slab, and prestressing tendon anchorages in a PC slab. Shear connectors are generally of welded construction, so attention should be paid to the fatigue durability of the welds. To verify the fatigue durability of the steel portion of a steel-concrete composite slab, two methods are available: static testing or FEM analysis to determine the range in which stresses are induced in the steel portion and then to verify the fatigue durability of the steel based on standard fatigue strength classes. Because there may be cases where the stress at the point of interest is affected by alternating loading as wheels pass over, the point at which the load acts and the method of applying the load need to be carefully studied.

14.4.4 Influence of water

- (1) A waterproof layer should be used to protect against infiltration of water from the slab surface, which could damage the fatigue resistance of the slab.
- (2) If a waterproof -layer is not used, the slab fatigue resistance shall be verified in consideration of the influence of water on the slab.

【Commentary】

- (1) It is known from water-immersion wheel-loading tests that the fatigue durability of a slab significantly decreases when there is standing water on its top surface. To prevent water penetrating the road surface and collecting on the top of the slab, a waterproof layer should be installed.
- (2) If no waterproof layer is installed, the effect on fatigue resistance of water standing on the slab surface needs to be taken into account.

14.5 Corrosion Resistance and Resistance to Material Deterioration

The materials used for the slab of a steel or composite structure shall exhibit sufficient corrosion resistance and resistance to material deterioration.

14.5.1 Resistance to steel corrosion

Steel components of the slab shall exhibit corrosion resistance.

- (1) steel corrosion
- (2) corrosion of steel used in the concrete

【Commentary】

This section specifies, of the durability performance requirements for a slab, the basic performance with respect to changes in the materials used for the slab over time. The slab should not suffer harmful degradation or damage, leading to a decline in safety and serviceability, as a result of actions on the components of the slab over the design service life of the slab. Although the slab should be provided with a waterproof layer, as described in Section 14.4, the slab should be highly resistant to material corrosion and degradation under the action of carbon dioxide, rainwater, and chemical components entering from the sides and bottom of the slab even if there is no waterproof layer or it fails to function.

The width of cracks in the concrete has a very great effect on the corrosion resistance of the steel reinforcement used in the concrete. Where the concrete contains steel, the allowable crack width needs to be determined by taking into account local environmental conditions, the type of steel used, and the concrete cover depth. The Standard Specifications for Concrete Structures [JSCE, 2002b] specify the allowable crack width in relation to steel corrosion according to environmental conditions and the type of steel. This allowable crack width relates to the minimum restriction on crack width that should be imposed so as to avoid corrosion. In a corrosive environment or a particularly severe corrosive environment, it is to be noted that crack widths should be controlled to below this allowable crack width and, at the same time, the requirement for chloride ion concentration at the depth of the steel needs to be satisfied. The allowable crack width in relation to watertightness is determined according to the required degree of watertightness and the dominant member forces acting on the slab by taking account of how the structure is to be used and the characteristics of loads acting on the structure.

Cracks caused by the thermal stress arising from the heat of hydration of cement during curing are detailed in Report on Evaluation and Study of Effectiveness of Expansive Additives for Cast-in-situ PC Slabs [Japan Bridge Association, 2004]. The allowable crack width in relation to watertightness as addressed in past research as well as overseas specifications regarding allowable crack width are detailed in the Guidelines for Survey, Repair and Reinforcement of Cracks in Concrete 2003 [Japan Concrete Institute, 2003].

- (1) For requirements related to the resistance to corrosion of steel exposed to the outside air, such as the bottom steel plates of a steel slab or a composite slab, the recommendation is to refer to Section 8.2.2 Corrosion Resistance, because the requirements are similar to those for the resistance to corrosion of steel members in general. For verification, it is recommended to refer to Section 8.3.2 Verification of Corrosion Resistance.
- (2) Major factors causing the corrosion of reinforcing steel in concrete are carbonation and salt dam-

age. For requirements related to resistance to steel corrosion due to carbonation of the concrete, it is recommended to refer to Section 8.2.2 Corrosion Resistance, because the requirements are similar to those for the resistance the corrosion of concrete members in general. For verification, it is recommended to refer to Section 8.3.2 Verification of Corrosion Resistance.

Leading causes of salt damage are salt, carried by sea spray and onshore winds, being deposited on the concrete surface and moving into the concrete, where it corrodes the steel, and anti-freeze agents such as calcium chloride that are applied to roads in cold climates. For requirements related to the former, it is recommended to refer to Section 8.2.2 Corrosion Resistance, because the requirements are considered similar to those for the resistance of concrete members in general. For verification, reference should be made to the approximation formula for calculating chloride ion concentration in concrete in the section titled "Concrete Subjected to the Actions of the Sea Water" of the Japanese Architectural Standard Specifications [Architectural Institute of Japan, 2003] in addition to Section 8.3.2 Verification of Corrosion Resistance.

In the case of the latter, where water containing an anti-freeze agent is applied above the top of the slab, it is considered effective to protect the slab using a waterproof layer. To protect the slab from salt damage resulting from the use of an anti-freeze agent, requirements for and verification of the waterproofing system are applicable and detailed in Report on Evaluation of Durability of Highly-functional Waterproof System [Highly-Functional Waterproof Committee, 2004].

14.5.2 Resistance to concrete deterioration

Concrete components of the slab shall exhibit sufficient resistance to material deterioration.

- (1) Damage due to alkali-aggregate reaction
- (2) Damage due to frost
- (3) Damage due to Chemical action

【Commentary】

- (1) For requirements for the protection of concrete damage due to the alkali-silica reaction, it is recommended to refer to Section 8.2.3 Resistance of Materials to Degradation, because the requirements are considered similar to those for the protection of concrete members in general. For verification, it is recommended to refer to Section 8.3.3 Verification of Resistance of Materials to Degradation.
- (2) For requirements for the protection of concrete from frost damage, it is recommended to refer to Section 8.2.3 Resistance of Materials to Degradation, because the requirements are considered similar to those for protection of concrete members in general against frost damage. For verification, it is recommended to refer to Section 8.3.3 Verification of Resistance of Materials to Degradation.
- (3) For requirements for the protection of concrete from damage due to chemical action, it is recommended to refer to Section 8.2.3 Resistance of Materials to Degradation, because the requirements are considered similar to those for the protection of concrete members in general. For verification, it is recommended to refer to Section 8.3.3 Verification of Resistance of Materials to Degradation.

14.6 Slabs of Various Types

A slab shall be appropriately designed and then constructed in the field so as to perform as required with respect to each performance item.

【Commentary】

The materials used to construct slabs include steel and concrete. For RC slabs, which have a long track record, steel slabs, PC, which have recently found wide application, and composite slabs, structural details are available for various slab types that have been determined from experience and in consideration of constructability. In many cases, similar structures are realized by sticking closely to these details. This section describes typical structural details of slabs of various types that have a long track record of use for road bridges.

14.6.1 Reinforced concrete slab

An RC slab shall be designed such that it satisfies each performance item. Performance shall be considered as satisfied through the observing of appropriate structural details.

- (1) Slab thickness
- (2) Connection to main girder
- (3) Execution precision
- (4) Reinforcement at girder end

【Commentary】

RC slabs have found many applications in road bridges. The specifications for such slabs are prescribed in the Specifications [Japan Road Association, 2002b]. The Specifications have been updated when necessary based on the results of investigations of damage, if found. The contents of the Specifications are very persuasive even though they are not theoretically based. This section describes typical structural details of RC slabs as prescribed in the latest Specifications.

- (1) Thickness of RC slab

The Specifications define the thickness of the RC slab. In the general, where the main steel reinforcement is arranged in the transverse direction, the basic slab thickness, t (mm), is given as $40L + 110$ for two-girder slabs and $30L + 110$ for multi-girder slabs (and not less than 160 mm in both cases), where L is the span of the slab (m). In actual design, the slab thickness is increased by multiplying the basic slab thickness by a factor derived from the volume of large-sized vehicle traffic (thickness increased by 25% at maximum) and a factor derived from the additional bending moment caused by differences in the rigidity of the girders. Specifications are also given for cases where the slab has a cantilever section and where the span of the slab is in the direction of vehicle flow.

The above equations for slab thickness are applicable to slabs of span L up to 4 m; they are not applicable to slabs beyond this maximum.

- (2) Slab to main girder connections

The Specifications prescribe that the slab should, as a general rule, be provided with reinforced haunches for connection to the support girders. Haunches effectively prevent cracks from occurring by reducing tensile stresses induced by the action of the slab in the vicinity of the main girders as well as distributing local stresses induced in the shear connector connecting slab to girder. The Specifications prescribe that additional reinforcing bars (haunch bars) should be provided for haunches that are 80 mm or more in depth.

- (3) Assurance of construction accuracy

The Specifications prescribe that rebars of size D13, D16, D19, or D22 should be used as a general rule and that, having selected a suitable diameter that is not too large, they should be arranged at an appropriate spacing so as to distribute cracks, control crack width, and minimize rebar deflection and bending during construction. This ensures that errors in the cover depth and alignment of rebars due to deformation of the bars during construction are a minimum.

(4) Reinforcement of the slab at girder ends

At girder ends, the slab loses continuity and is subjected to impulsive loads caused by level differences at the expansion joints. These loads induce large bending moments in the direction of the main reinforcement and, consequently, the slab is prone to damage. To avoid this, the Specifications prescribe that, at girder ends, the slab should be able to resist these loads by introducing cross girders or brackets at the girder end points, increasing the slab thickness, or arranging additional rebars.

14.6.2 Pre-stressed concrete slab

A PC slab shall be designed such that it satisfies each performance item taking into account construction by pre-casting or post-casting. Performance shall be considered as satisfied through the observing of appropriate structural details.

- (1) Slab thickness
- (2) Connection to main girder
- (3) Connection between slabs
- (4) Reinforcement at girder end

【Commentary】

The specifications for PC slabs are prescribed in the Specifications, as is the case with RC slabs. For RC slabs, the span direction is aligned with the orientation of the main reinforcement. For PC slabs, the span direction is in some cases different from the direction in which the prestressing forces are introduced. The Specifications prescribe the slab thickness in each case. This section deals with typical structural details in the most common case where the span direction of the slab and the direction in which the prestressing forces are introduced are perpendicular to the direction in which vehicles operate.

(1) Minimum thickness of PC slab

The Specifications prescribe that the minimum thickness of the PC slab under the above-mentioned conditions should be 0.9 times the thickness of an RC slab: that is, $(40L + 110) \times 0.9$ (mm) for two-girder slabs and $(30L + 110) \times 0.9$ (mm) for multi-girder slabs. The required increase in thickness for traffic volume and uneven settlement is the same as for RC slabs. The PC slab can be made thinner than the RC slab because, when prestressing forces are introduced in the direction of the span, the bending moment induced under loading in the direction perpendicular to the span is smaller in the PC slab than in the RC slab. (See 5.4.2 Commentary of Part III Concrete Bridges of the Specifications.)

The maximum span was set at 4 m (with 1.5 m cantilevered sections) for RC slabs and is 6 m (with 3 m cantilever sections) for PC slabs. However, RC slabs with large spans have recently been designed; taking the Warashinagawa Bridge on the Second Tomei Expressway as an example, slabs with a span of 11 m and a thickness of 360 mm at the center of the span (530 mm on the girders) are adopted.

(2) Slab to girder connections

A post-tensioned PC slab is usually connected to the girders with stud shear connectors, as is the case with an RC slab. At the connection points, a PC slab is generally provided with haunches, as with an RC slab. Taking the Warashinagawa Bridge as an example, the haunches take the form of a large arch extending from the girder support to the center of the span.

A pre-tensioned PC slab is connected to the girders by the same method as a post-tensioned PC slab, i.e. with shear connectors. Because the size of the openings in a precast slab at the girders is limited, thick or screwed shear connectors are in some cases used in consideration of

transportability and constructability. High-performance concrete has been used reliably to fill the space between girders and a precast slab.

(3) Connections between slabs

A standard joint (called a loop joint) is used to connect precast PC slabs together. For reference, a sectional view of a loop joint is shown in Fig.C14.6.1.

Needless to say, this joint is of RC structure, and is adopted as a general joint for PC slabs after loading tests have been carried out.

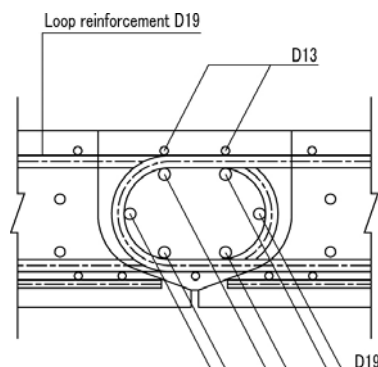

Fig.C14.6.1 Loop joint

(4) Reinforcement of slab end

At girder ends, concrete needs to be cast down to the expansion joints and girder end cross girders even when a pre-tensioned PC slab is used. For this reason, the structure of a post-tensioned PC slab or RC slab is, in many cases, adopted at girder ends. The concept of reinforcement design for RC slabs, including the doubling of the design bending moment at the girder ends, applies correspondingly to PC slabs.

The Manual for Design and Construction of PC Slab Steel Continuous Composite Two-Girder Bridges [Expressway Technology Center, March 2002] points out that it is necessary to fully confirm that the predetermined prestress is introduced into the slab in the vicinity of cross girders and expansion joints at the slab end. As regards the member forces induced by prestressing, the this manual describes the following design concept:

- ① Lay out prestressing tendons and introduce prestressing forces so as not to induce tensile stress in the PC slab under the dead load.
- ② Lay out prestressing tendons and introduce prestressing forces so as not to cause cracks in the PC slab under the dead load and live load.

The concept of allowing tensile stress to be induced and cracks to form in prestressed reinforced concrete (PRC) depending on the combination of loads is also described in the manual.

14.6.3 Steel-concrete composite slab

A steel-concrete composite slab shall be designed such that it satisfies each performance item. Performance shall be considered as satisfied through the observing of appropriate structural details.

- (1) Slab thickness
- (2) Shear connector
- (3) Reinforcement at girder end

【 Commentary 】

Most steel-concrete composite slabs are of relatively new structure. Although in basic form they comprise steel and concrete, there is an extremely wide variety of structure types: for example, there

are composite slabs consisting of steel plate or sectional steel and concrete in which flat bars, shear connectors, or bent truss rebars transmit the shear forces; and there are composite slabs of sandwich structure with superplasticized concrete placed between upper and lower steel plates or sectional steel.

This section describes the structural details of a typical composite slab called the Robinson type. This is a composite slab in which shear connectors are provided on the bottom steel plate, rebars are laid over the top of the steel plate, and then concrete is placed.

- (1) Thickness of steel-concrete composite slab The Guidelines for Design of Steel Structures - Part B [JSCE, 1997] include an equation for calculating the minimum thickness of the concrete part of a steel-concrete composite slab Eq.(C14.6.1).

$$h_c = 25L + 100 \quad (\text{mm}) \quad (\text{not less than } 150 \text{ mm}) \quad (\text{C14.6.1})$$

where, L =span of the slab (m)

This equation is applicable to slabs subjected to a bending moment where the maximum span, L , is 8 m. Comparing the minimum thickness of the composite slab with that of the PC slab, there is no need to secure a concrete cover depth from the bottom steel plate of the composite slab, and these guidelines adopt a value that yields a composite slab thinner than the PC slab by an amount approximately equal to the lower concrete cover depth. When the bottom steel plate is included in the calculation of the composite cross section (note that there is a type of composite slab in which the bottom steel plate is a non-strengthening member), the standard thickness of the steel plate is about 8 mm.

The equation also applies to composite slabs that use other types of steel bottom plate.

- (2) Shear connectors

The above guidelines specify that shear connectors of well-tested design be used and that they should be designed so as to fully distribute the forces acting on the slab. The standard sizes of the shear connectors are specified as $\phi 16$ and $\phi 19$ mm so as not to cause harmful deformation of a slab that has a relatively thin bottom plate. The shear connectors should be evenly spaced 250 mm apart at maximum and 100 mm apart at minimum. The length of the shear connectors should be designed so that the top of a connector under positive bending moment is in compression.

Based on test results, these guidelines specify that the shear stress, taking into account the fatigue acting on the shear connectors, should be limited to not more than 500 kgf/mm² (49 N/mm²).

- (3) Reinforcement of slab at girder ends

Since a composite slab loses continuity at the girder ends and is subject to impulsive loading caused by level differences at the expansion joints, the slab is designed with increased thickness at girder ends, as in the case of RC slabs. In the case of a skew bridge, additional rebars are provided in a skew direction, as in the case of RC slabs.

To reinforce the bottom steel plate in the vicinity of the girder ends, the number of rebars is increased or additional rebars are arranged in the skew direction.

Recently, composite slabs this thickening at girder ends have been introduced to reduce the man-hours needed to machine the slab. In this case, a structural analysis is carried out to confirm that the bending moment induced in the slab, with concrete placed down to and enveloping the end cross girders, remains small enough that it presents no structural problems at the girder ends where the continuity is lost and the slab is subjected to impulsive loading.

14.6.4 Orthotropic steel deck

An orthotropic steel deck shall be designed such that it satisfies each performance item. Performance shall be considered as satisfied through the observing of appropriate structural details.

- (1) Thickness of steel deck
- (2) Effective width

【Commentary】

(1) Thickness of steel slab

The thickness of a steel slab deck plate should be not less than the following values for road bridges:

$$\text{Roadway (under live load B)} \quad : \quad t = 0.037 \times b \quad \text{where } t \geq 12\text{mm} \quad (\text{C14.6.2})$$

$$\text{Roadway (under live load A)} \quad : \quad t = 0.035 \times b \quad \text{where } t \geq 12\text{mm} \quad (\text{C14.6.3})$$

$$\text{Sidewalk that acts as part of main girder} \quad : \quad t = 0.025 \times b \quad \text{where } t \geq 10\text{mm} \quad (\text{C14.6.4})$$

where b = spacing between vertical ribs (mm)

The thickness of the deck plate for a sidewalk that does not act as part of the main girder can be taken as 8 mm.

- a) The minimum plate thickness of the vertical ribs should be 8 mm. If the corrosion environment is categorized as good or if adequate attention is paid to corrosion prevention, the minimum plate thickness of the ribs with a closed cross section can be taken as 6 mm.
- b) Where a vertical rib intersects with a cross girder, the vertical rib should be as a general rule penetrate the cross girder and be welded to it.

This requirement is described in the specifications for road bridges [Japan Road Association, 2002b]. In the case of railway bridges, a similar requirement is made in Design Standards for Railway Structures (Steel and Composite Structures) [Railway Technical Research Institute, 2000]. For a steel slab with ballasted track, these standards include the following requirements: ① the minimum thickness of the steel slab should be 12 mm and the spacing between vertical ribs should be not more than 30 times the slab thickness, ② the height of rectangular cross section vertical ribs should be not more than 12 times the slab thickness, and ③ where a vertical rib intersects with a cross girder (horizontal rib), the vertical rib should penetrate the cross girder and be welded to it.

- (2) Effective width of steel slab In Section 8.4.4 of the above specifications, the method of loading, the effective width of steel slab, and the standard values of bending moment and shear force used for the design in the ultimate limit state are specified [Japan Road Association, 200b]. Structural details, such as the layout and design of ribs, can be determined in accordance with the specifications.

Other standards are described below.

- 1) Design Standards for Railway Structures (Steel and Composite Structures) [Railway Technical Research Institute, 2000]

In the Design Standards for Railway Structures, the requirements for steel slabs are specified in Chapter 12 Floor Framing. The steel slab in these design standards is defined as a steel plate reinforced with vertical ribs and horizontal ribs (or cross girders) to support the ballast. It is specified in Chapter 14 Plate Girders that in the case of deck plate girder bridges of steel slab type, because the steel slab acts as not only a slab but also the main girder flange, the member forces of the slab as a main girder and the member forces specified in Chapter 12.7 should be used for verification of the slab.

The requirements set out in Chapter 12 are outlined below.

① Structure of steel slab

- a) For ballasted track, the minimum thickness of the slab should be 12 mm and the spacing between the vertical ribs should, as a general rule, be not more than 30

times the slab thickness.

- b) The height of the rectangular cross section vertical ribs should be not more than 12 times the slab thickness.
- c) Where a vertical rib and a cross girder intersect, the vertical rib should penetrate the cross girder and be welded to it.

② Design of vertical ribs for steel slab

The method of loading, the effective width of the steel slab, and the standard values of bending moment and shear force used for design in the ultimate limit state are specified.

③ Design of cross girders for steel slab

The method of loading, the effective width of the steel slab, and the method of calculating the bending moment are specified.

2) American Association of State Highway and Transportation Officials (AASHTO)

The AASHTO Specifications [AASHTO LRFD Bridge Design Specifications, AASHTO, 2003] describe general requirements for the analysis of steel slabs, the distribution angle of wheel loads, the concept of the composite effect of slab and pavement, refined methods of analysis, methods of approximate analysis, and detailed requirements. These specifications include cross-references to Chapter 2 General Design and Location Features, Chapter 4 Structural Analysis and Evaluation, and Chapter 6 Steel Structures.

3) The European Committee for Standardization (EUROCODE 3 (CEN, 2003))

In the EUROCODE, detailed specifications are described in Appendix C: Recommendations for Structural Details of Steel Slabs of EUROCODE 3/Part 2: Steel Bridges. This appendix comprises three chapters: C1 Road Bridges, C2 Railway Bridges, and C3 Half-finished Products and Manufacturing Accuracy. In Appendix E Combination of Effects of Wheel and Tire Loads and Traffic Loads of Road Bridges, combinations of the actions of slab, floor framing, and main girder are specified.

References in Chapter 14

- Kazuo Tada(1971) : Practical Calculation Method of Steel Plate Decks by Finite Strip Method, Bridge and Foundation Engineering, Vol.5, No.5, pp.6-14.Finite Strip Method .
- Shozo Yamaga, Japan Highway Public Corporation Research Institute Report(1977) :Survey on Low-frequency Airborne Vibration - Survey of Actual Situation of Sound Pressure and the Influence on Houses, pp.311-323.
- Shinji Yamada, Toshifumi Kosaka, Kiyoto Nakazawa(1978) : Noises and Vibrations, A Consideration on the Reduction of Bridge Vibrations, Vol.2, No.5, pp.22-25.
- Hideo Uchida, Hidemi Kurita(1979) :Nagano Research Institute for Health and Pollution Report, Low-frequency Airborne Vibration and noises/vibrations from the Achigawa Bridge of the Nishinomiya Line, Chuo Expressway, Vol.11, pp.80-91.
- Akira Ishii, Shigeo Higuchi, Masayoshi Mizukami, Teruhisa Negi, Keiichi Matsushima, Hiroshi Mafune(1981) : Chiba Prefectural Research Institute for Environmental Pollution Report, Low-frequency Airborne Vibration around the Keiyo Road at Yatsu, Narashino City, Vol.13, No.1, pp.1-7.
- Kazuo Shimizu, Hiroaki Ochiai(1982) : Noises and Vibrations, Measurement of Bridge Vibrations and Low-frequency Sounds, Vol.6, No.6, pp.15-18.
- Japan Road Association(1987) : Road Earthworks - Guidelines for Drainage Works.
- Shigeyuki Matsui(1987) : On the Fatigue Strength of Highway Bridge RC Slabs under Moving Loads and the Influence of Water, JCI Annual Convention Proceedings, 9-2, pp.627-632.
- Bridge Research Laboratory, Department of Structures and Bridges, Public Works Research Institute, Ministry of Construction(1988) : PWRI Research Report, A Study on the Design Live Load in Limit State Design Method II, PWRI Research Report No.2700.
- Shigeyuki Matsui(1991) : Prediction of the Span of Life of Bridges, Prediction of the Span of Fatigue Life of

- Highway Bridge RC Slabs, Journal of Japan Society for Safety Engineering, Vol.30, No.6, pp.432-440.
- Shigeyuki Matsui, Keizo Egashira, Shigeru Ishizaki(1995) : A Few Considerations on the Design Bending Moment Formula for Long-span Slabs, Journal of Constructional Steel, Vol.3, pp.215-220.
- Pavement Research Laboratory, Department of Roads, Public Works Research Institute, Ministry of Construction(1995) : PWRI Research Report, Analysis of the Survey Results on Vehicle Weight (No.4), PWRI Research Report No.3321.
- Takeshi Mori, Hitoshi KAAjiwara, Yosuke Hasegawa(1995) : The Development and Its Use of the Program to Examine the Fatigue Safety Performance of Steel Structures Based on the JSSC Guidelines, Steel Construction Engineering, Vol.2, No.8.
- Japan Society of Civil Engineers (1997) : Design Code for Steel Structures, PART B; Composite Structures.
- Hideaki Nagayama, Kazuomi Ichikawa, Atsunori Kawabata, Yasuhiro Imura(1998) : Experimental Study on Strength of Slabs Performed with Long-span Precast PC-panel Rib, Proceeding of 1st Symposium on Decks of Steel Highway Bridges, pp.143-148.
- Koichi Sato, Takashi Kaneda, Hiromichi Yoshikawa, Katsumi Kodama(1998) : A Study on Two-way Deterioration Ratio of Reinforced Concrete Slabs, Proceeding of 1st Symposium on Decks of Steel Highway Bridges, pp.31-36.
- Toshio Yasumatsu, Toshihiko Hase, Shuji Shinohara, Yoshimasa Nagase(1998) : A Study of the Fatigue Design of the Slab of Steel Bridges to Considered the Traffic Axle Load, Proceeding of 1st Symposium on Decks of Steel Highway Bridges, pp.77-82.
- Murai, Noise Control(1999) : Road Business and Low-frequency Sound, Vol.23, No.5, pp.319-323.
- Toshihiko Hase, Yasushi Kamihigashi, Toshio Yasumatsu(1999) : Estimation of the Durability of Long-span PC Slabs by Moving Wheel Load Fatigue Tests, Japan Highway Public Corporation Research Institute Report, Vol.36, pp.25-34.
- Moto Ikoma, Atsushi Honma, Koki Sugizaki, Tatsuhiko Kasai(1999) : A Study on the Examination Method on the Limit State of PC Slabs, 55th Annual Conference of the Japan Society of Civil Engineers, CS-285.
- Railway Technical Research Institute(2000) : Design Standards for Railway Structures and Commentary, Steel and Composite Structures .
- Sumio Sakamoto, Akihiro Nakasono, Yoshiyuki Yasukawa, Naofumi Inaba, Masatsugu Nagai (2002) : A Simplified Method to Evaluate Bending Moment due to Dead Loads for PC slab decks consisting of two plate girdes, Journal of Structural Engineering, Vol.48A, pp.1409-1416.
- Atsushi Honma, Toshihiko Hase, Kazushige Sakakibara, Kazumi Nakamura, Tadashi Uehara, Tatsuhiko Kasai(2002) : Design and Construction of Long-span Cast-in-situ PC Slabs, Bridge and Foundation Engineering, Vol.36, No.10, pp.2-10.
- Japan Road Association (2002a) : Specifications for Highway Bridges and Commentary, I Common Specifications Volume.
- Japan Road Association (2002b) : Specifications for Highway Bridges and Commentary I Common Specifications, II Steel Highway Bridges Volume.
- Japan Society of Civil Engineers (2002a) : Standard Specification for Concrete Structures, Construction Volume.
- Japan Society of Civil Engineers (2002b) : Standard Specification for Concrete Structures, Structural Performance Verification Volume.
- Architectural Institute of Japan(2003) : Japanese Architectural Standard Specifications, JASS5 Reinforced Concrete Work 2003, pp.518-532.
- Japan Concrete Institute(2003) : Guidelines for Survey, Repair and Reinforcement of Cracks in Concrete - 2003-.
- Toshio Yasumatsu, Izumi Tanaka, Yasuhiro Sshimura, Tomonori Nakahara, Taro Tonegawa (2003) : Study on Design of In Place PC Slab of continuous rigid frame 2- girder Bridge, Proceeding of 3rd Symposium on Decks of Highway Bridges, pp.103-108.
- Yasuo Kajikawa, Prestressed Concrete(2003) : The Present Situation of Bridge Traffic Vibrations and Environmental Countermeasures, Vol.45, No.4, pp.37-42.
- Atsunori Kawabata, Takuya Murakami(2004a) : Dynamic Characteristics of Highway Bridges Deck Slabs, Proceeding of 4th Symposium on Decks of Highway Bridges, pp.79-84.

- Atsunori Kawabata, Reiko Akimoto(2004b) : Performance Based Design Method for Fatigue Strength of RC Slab, Proceeding of 4th Symposium on Decks of Highway Bridges, pp.179-184.
- Japan Society of Civil Engineers(2004a) : Performance-Based Design of Decks of Highway Bridges, Rational Design and Higher Durability of Decks of Highway Bridges, pp107-108.
- Japan Society of Civil Engineers(2004b) : Moving Wheel Load Test of Decks, Rational Design and Higher Durability of Decks of Highway Bridges.
- Highly-Functional Waterproof Committee(2004) : Report on Evaluation of Durability of Highly-Functional Waterproof System for Decks of Highway Bridges.
- Japan Bridge Association, Expansive Additives Association(2004) : Report on Evaluation and Study of Effectiveness of Expansive Additives for Cast-in-situ PC Slabs.
- Chitoshi Miki, Hisatada Suganuma, Masayuki Tomizawa, Fumitaka Machida(2005) : Case Study on Fatigue Damage in Orthotropic Steel Bridge Deck, Structural Eng./Earthquake Eng., JSCE, No.780/I, pp.57-70.
- Chitoshi Miki, Yuji Goto , Hitoshi Yoshida , Takeshi Mori (1985) : Computer simulation studies on the fatigue load and fatigue design of highway bridges ,Journal of Structural Mechanics and Earthquake Engineering of JSCE , No.356 , pp.37-46 .
- AASHTO(2003) : AASHTO LRFD Bridge Design Specifications- S.I. Units 2003 Interim Revisions .
- CEN(2003) : prEN 1993-2 : Eurocode 3 : Design of steel Structures, Part 2 : Steel Bridges, Stage 34 draft .

Chapter 15 Design of Composite Girders

15.1 General

This chapter shall apply to a steel-concrete composite girder, in which a concrete deck or a composite deck formed of steel and concrete is unified to the steel girders with shear connectors. In the design of a composite girder, verification shall be done to confirm the required performance regarding safety and serviceability of the girders as well as the connectors.

【Commentary】

In design of a composite girder which consists of RC deck, PC deck or steel-concrete composite deck (see Chap.14) and the steel girders unified to it with share connectors, the required performance at the serviceability limit state, safety limit state and so on shall be satisfied. Design consideration on durability is also important. As for design of the steel girder section which resists own weight and the deck weight, please refer to Chapter 5.

When the same grade steel is used for flanges and web, the steel girder is called homogeneous type, and a girder is called hybrid type when the steel strength for the web, which usually receives smaller stress, is lower than the steel for flanges. Although the hybrid type seems to be effective for cost reduction, this chapter will cover only the homogeneous type because the hybrid girders have been rarely constructed in Japan.

There are two types of the composite girder, each which has different stress distribution inside the steel girder and concrete deck. One is the shored construction in which whole dead load and live load are resisted with the composite cross section. Another is unshored construction. In this structural system, the weight of steel and concrete (the first phase dead load) is resisted with the steel girder only, and the second phase dead load such as curb, pavement and attachment as well as the live load are supported with the composite cross section. At the intermediate supports where cracks are generated into the concrete deck due to negative bending moment, the load is resisted with the structural system composed of the steel girder and rebars in the deck.

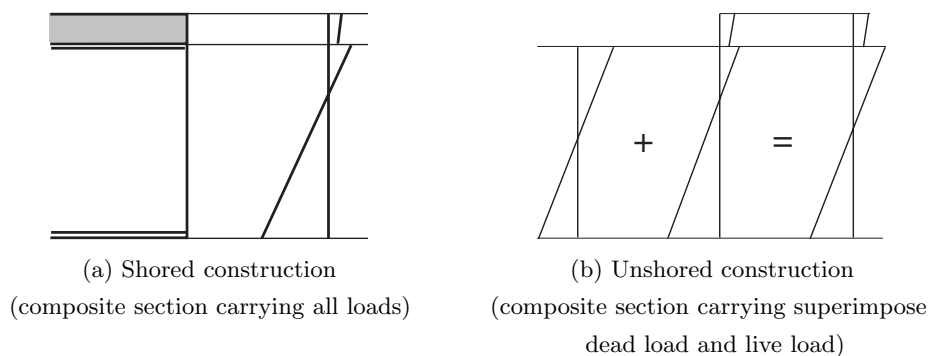

Fig.C15.1.1 Stress in composite girders

At the serviceability limit state, the required performance of structure is such that; 1) excessive deflection of the girder is not generated, 2) the steel member is free from permanent strain and keeps the elastic behavior, 3) crack width in the concrete deck at intermediate supports is within allowable range, and 4) no fatigue by repeating traffic load is introduced to welded portions of the web.

The above mentioned requirements are to be ascertained as the followings.

- 1) Deflection under the live load including impact shall be less than the value given in Highway

Bridge Specification [JRA, 2002]

- 2) Normal stress, shear stress and their equivalent stress shall be less than yield point of the steel.
- 3) Crack width in the deck shall be less than acceptable value defined based on environmental consideration. The calculation and verification will be described in 15.6.
- 4) Web bleeding is a phenomenon that a thin web plate repeats out-of-plane deflection (elastic buckling) because of the traffic load, and this deflection may cause fatigue damages to portions such as the fillet welding between the flange and web, vertical stiffeners, corner of flange and web. In order to prevent such damages, limit value of the depth-to-thickness ratio of web as a function by the span length is given in Eurocode [CEN, 2003].

At the safety limit state, safety of the structure under action of bending, shear and their combination shall be confirmed. The composite girder is classified into three categories depending on the depth-thickness ratio of web plate: compact section, noncompact section and slender section. The compact section can raise its ultimate bending strength up to the fully plastic moment without suffering any local buckling, and the noncompact section raises the strength higher than the yield moment but less than the fully plastic moment. The slender section cannot reach the yield moment because of the web buckling. In this chapter, the verification methods of safety will be discussed with the above mentioned definitions.

It shall be pointed out that verification about the fatigue limit state is not mentioned here.

15.2 Strength of Composite Girder

15.2.1 Classification of cross sections

- (1) For calculation of the bending strength, cross sections of composite girders are classified by the same way for steel girders specified in Chapter 5: namely (a) compact section, (b) noncompact section, and (c) slender section.
- (2) When a compression flange of the steel girder is effectively restrained from buckling with a concrete deck by sufficient shear connectors, the section can be classified in accordance with only the depth-thickness ratio of the web plate of steel girder.
- (3) For a composite girder receiving negative bending moment or having a steel compression flange that is not sufficiently unified to the concrete deck, the classification of cross section shall be done in accordance with the steel sections as being defined in 5.3.3.1.

【Commentary】

- (1) Fig.C15.2.1 shows relationships between the bending moment and curvature for each section. In this figure, M_{pl} and M_y denote the plastic and yields moments, respectively.

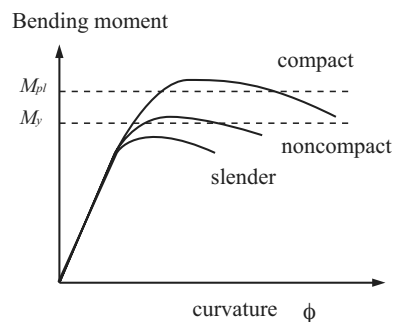

Fig.C15.2.1 Bending moment-curvature relationship of composite girder and section classification

(2) Section classifications in AASHTO and Eurocode

Table C15.2.1 shows a summary of section classifications in AASHTO [AASHTO, 2005] and Eurocode [CEN, 2003]. In this table, criteria for only web plate are listed, on condition that there is no possibility of buckling in the compressive flange plate of composite girders under positive bending moment. In the table, t_w and b_w are the thickness and depth of the web plate respectively, and the other symbols are defined in Figs.C15.2.2 and C15.2.3.

Table C15.2.1 Section classification in Eurocode and AASHTO

	Class	Definition	Thickness/depth of web plate
AASHTO	Compact	$M_{max} \geq M_{pl}$	$2D_{cp}/t_w \leq 3.76\sqrt{E/f_y}$
	Noncompact	$M_{max} \geq M_y$	$2D_c/t_w < 5.7\sqrt{E/f_y}$
	Slender	$M_{max} < M_y$	other than those above
Eurocode	Class 1	$M_{max} \geq M_{pl}$	$b_w/t_w \leq \begin{cases} 36\varepsilon/\alpha & \text{for } \alpha \leq 0.5 \\ 396\varepsilon/(13\alpha - 1) & \text{for } \alpha > 0.5 \end{cases}$
	Class 2	$M_{max} \geq M_{pl}$	$b_w/t_w \leq \begin{cases} 41.5\varepsilon/\alpha & \text{for } \alpha \leq 0.5 \\ 456\varepsilon/(13\alpha - 1) & \text{for } \alpha > 0.5 \end{cases}$
	Class 3	$M_{max} \geq M_y$	$b_w/t_w \leq \begin{cases} 42\varepsilon/(0.67 + 0.33\psi) & \text{for } \psi > -1.0 \\ 62\varepsilon(1 - \psi)\sqrt{-\psi} & \text{for } \psi \leq -1.0 \end{cases}$
	Class 4	$M_{max} < M_y$	other than those above

E : Young modulus of the steel

f_y : Standard value of yield strength of the steel

$\varepsilon = \sqrt{235/f_y}$ [N/mm²]

(3) Section classification by confining effect due to the concrete deck and initial bending moment during erection

Since the section classification criteria for composite girders in both AASHTO 2005 and Eurocode 2003 are based on those for steel girders, the confining effect due to the concrete deck on web buckling in composite girders is not taken into account. Furthermore, in the unshored composite girder, only the steel girder has to support the whole dead load, which means that initial bending moment in the erection stage is left. However, the influence of the initial bending moment on the section classification criteria is not considered in AASHTO nor Eurocode.

Reference[JSSC, 2006], [Gupta *et al.*, 2006] and Draft for Limit State Design Methods for Composite Girders [JSSC, 2006] have proposed the section classification criteria in which the effects of both concrete deck and initial bending moment are taken into consideration. The composite section can be classified according to these references as shown below.

(a) Compact sections

When the depth-thickness ratio of the web plate satisfies the following criterion, the section is classified as compact sections:

$$\frac{b_w}{t_w} \leq \frac{2.0}{\alpha} \sqrt{\frac{E}{f_y}} \quad (\text{here, } \alpha < 0.4) \quad (\text{C15.2.1})$$

where α stands for the position of the plastic neutral axis (see, Fig.C15.2.2).

(b) Noncompact sections

Noncompact sections satisfies the followings:

$$\frac{b_w}{t_w} \leq \frac{1.7\Lambda}{0.67 + 0.33\psi} \sqrt{\frac{E}{f_y}} \quad (\psi > -1.0) \quad (\text{C15.2.2})$$

$$\frac{b_w}{t_w} \leq 2.5\Lambda(1 - \psi)\sqrt{-\psi} \sqrt{\frac{E}{f_y}} \quad (\psi \leq -1.0) \quad (\text{C15.2.3})$$

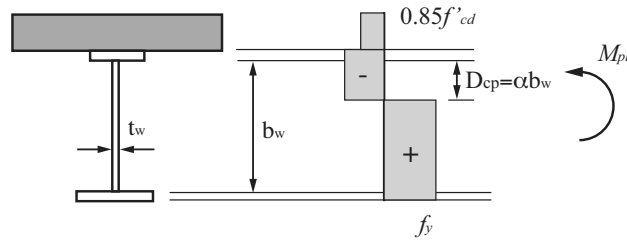

Fig.C15.2.2 Stress distribution in a compact section under full plastic moment

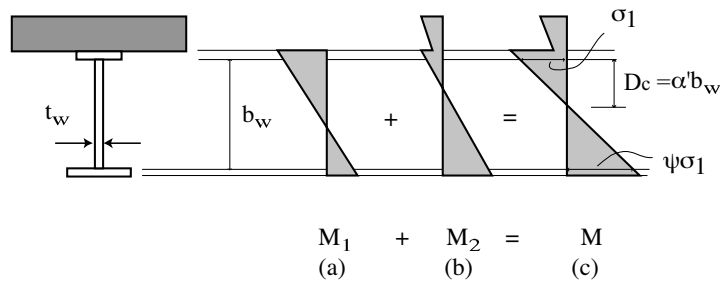

Fig.C15.2.3 Superposition of stress in unshored composite girder

here :

$$\Lambda = \left[1 - 0.1 \left(\frac{M_1}{M_{ys}} \right) + 2.31 \left(\frac{M_1}{M_{ys}} \right)^2 \right] \quad \left(\text{where, } \frac{M_1}{M_{ys}} \leq 0.4 \right) \quad \text{(C15.2.4)}$$

where, ψ is the parameter for stress gradient (see, Fig.C15.2.3) in the web; M_1 denotes the initial bending moment applied only steel section in unshored composite girders; M_{ys} is the yield moment of the bare steel section.

(c) Slender sections

Slender sections are defined as other than above two.

- (4) When the compressive flange plate of a steel girder is connected to the concrete deck with enough shear connectors, there is no possibility of buckling of the flange. Accordingly, section may be classified depending on the web plate only. Even in composite section receiving positive bending moment, the compressive flange has a potential for buckling when the pitch of shear connectors is too large. If so, the current provision must not be applied.
- (5) When the compressive flange plate is not unified with the concrete deck or when a composite girder receives negative bending moment, the section shall be classified in accordance with 5.2.

15.2.2 Design bending resistance

The design bending strength of a composite girder shall be determined by appropriate method(s) with consideration of the classification depending on either the compact, noncompact or slender section.

【 Commentary 】

(1) Bending strength

In general, the design bending strength of composite girders shall be determined by Eq.(C15.2.5) ~ Eq.(C15.2.8).

$$M_{rd} = M_r / \gamma_b \quad \text{(C15.2.5)}$$

$$\bullet \text{ For compact sections} \quad M_r = M_{pl} \quad (\text{C15.2.6})$$

$$\bullet \text{ For noncompact sections} \quad M_r = M_y \quad (\text{C15.2.7})$$

$$\bullet \text{ For slender sections} \quad M_r = M_{eff} \quad (\text{C15.2.8})$$

where, M_{rd} : design bending strength M_r : bending strength, M_{pl} : plastic bending moment, M_y : yield bending moment, M_{eff} : bending moment with consideration of the effective area of the steel member given in 5.3.3, γ_b : member factor.

Examples of the calculation of the bending strength by plastic theory or by elastic theory are described below.

(2) Calculation of the bending strength by plastic theory

M_r can be determined by plastic theory. Examples of plastic stress distributions for a composite girder in positive and negative bending moment are shown in Fig.C15.2.4, where, b_{eff} : effective width of the concrete deck, f'_{cd} : design compressive strength of concrete, f_{yd} : design yield strength of the steel member, f_{sd} : design yield strength of the reinforcement, $N_{c,f}$: plastic axial force of the concrete deck, N_{s1} , N_{s2} : plastic axial force of the reinforcement, $N_{pl}(+)$: plastic axial force of the steel member (tension side), $N_{pl}(-)$: plastic axial force of the steel member (compression side). The following assumptions are made in the calculation;

- There is no slip between steel member, reinforcement and concrete.
- The effective area of the steel member is decided by f_{yd} (either tensile or compressive).
- The effective area of the longitudinal reinforcement is decided by f_{sd} (either tensile or compressive). However, the reinforcement in a concrete deck under compression is to be neglected.
- The effective area of concrete in compression is decided by the effective width described in 15.7, and the concrete stress distribution between the upper surface of the concrete deck and the plastic neutral axis is assumed to be constant of $0.85f'_{cd}$.

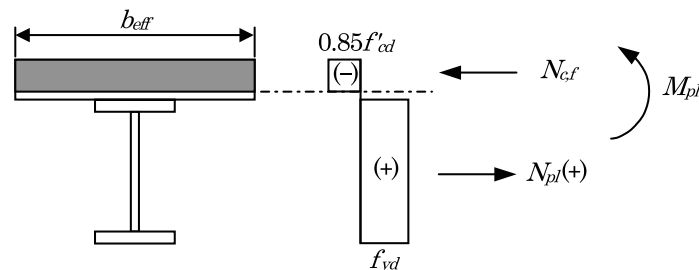

(a) When plastic neutral axis is within the concrete deck in positive bending

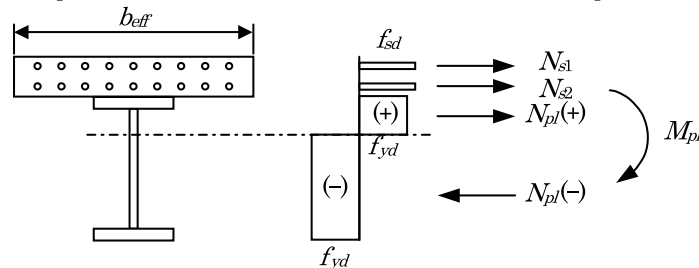

(b) When plastic neutral axis is within the web receiving negative bending

Fig.C15.2.4 Examples of plastic stress distributions for a composite girder in positive or negative bending moment (positive: tension)

According to Eurocode 4 [CEN, 2002], when composite cross sections is composed of steel grade S420 ($f_y = 420 \text{ N/mm}^2$) or S460 ($f_y = 460 \text{ N/mm}^2$) and when the distance x_{pl} between the upper surface of the concrete deck and plastic neutral axis exceeds 15 % of the overall depth h

as shown in Fig.C15.2.5, the bending strength M_r is to be βM_{pl} , where β is the reduction factor. In addition, when the values x_{pl}/h are greater than 0.4, the bending strength is to be determined by elastic theory or other appropriate methods.

Moreover, Eurocode 4 requires M_{rb} not to exceed $0.9M_{pl}$, when elastic analysis is used for a composite continuous girder with compact sections in positive bending moment area and when the girder meets both of following (a) and (b) conditions. Otherwise, use of more accurate inelastic global analysis is required.

- (a) A cross section under negative bending moment or cross section neighboring a support is either noncompact or slender.
- (b) The length ratio between both spans neighboring an intermediate support is less than 0.6 (shorter / longer).

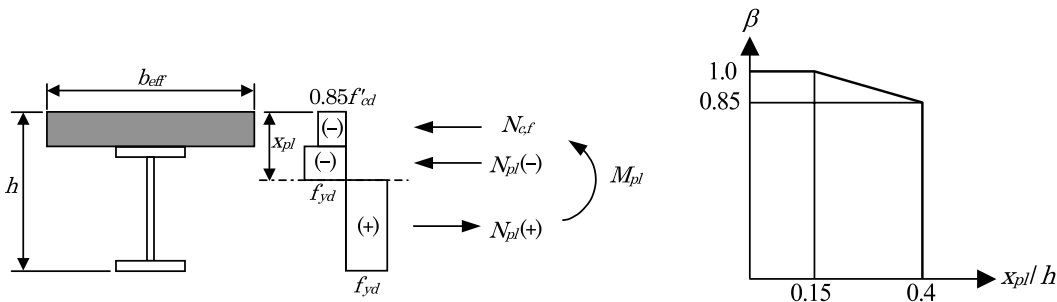

Fig.C15.2.5 Reduction factor β (positive: tension)

On the other hand, AASHTO [AASHTO, 2005] specifies the bending strength for the compact sections under positive bending moment to be determined by either Eq.(C15.2.9) or Eq.(C15.2.10) when the specified minimum yield strength of the steel flanges does not exceed 485 N/mm².

$$M_r = M_{pl} \quad (D_p \leq 0.1D_t) \quad (\text{C15.2.9})$$

$$M_r = M_{pl} \left(1.07 - 0.7 \frac{D_p}{D_t} \right) \quad (0.1D_t < D_p \leq 0.42D_t) \quad (\text{C15.2.10})$$

where, D_p : the distance between the upper surface of the concrete deck and plastic neutral axis (mm), D_t : total depth of the composite section.

However in a continuous span, M_r is required not to exceed the value decided by Eq.(C15.2.11), when the following either condition meets;

- (a) The span under consideration and both sections neighboring an intermediate support do not satisfy the prescribed requirement.
- (b) Sections of both spans neighboring an intermediate support do not satisfy the required plastic rotating capability.

$$M_r = 1.3R_h M_y \quad (\text{C15.2.11})$$

where, R_h : hybrid factor (= 1.0 for homogeneous sections) .

(3) Calculation of the bending strength by elastic theory

The design bending strength of compact, noncompact or slender sections can be determined by elastic theory. In use of the elastic theory, Bernoulli-Euler theory (a plane in the cross section before deformation keeps plane after the deformation) is assumed, and the effective width specified in 15.7 is to be considered. As for the characteristic strength, the followings should be premised:

- f'_{cd} : Concrete in compression. Generally, the area of concrete in tension is to be neglected.
- f_{yd} : Structural steel member in compression or tension.

- f_{sd} : Reinforcement in compression or tension. Generally, reinforcement in a concrete deck receiving compression may be neglected.

For the calculation of slender sections, the effective area of the steel member specified in 5.3.3 should be used.

15.2.3 Verification of bending moment

The bending moment of a composite girder shall be verified using the following:

$$\gamma_i \frac{M_{sd}}{M_{rd}} \leq 1.0 \quad (15.2.1)$$

where , M_{rd} : Design bending moment
 M_{sd} : Design bending strength
 γ_i : Structural factor

【 Commentary 】

The basic equation for verification is Eq.(15.2.1). The followings are examples of the verification to steel sections and composite sections.

(1) Verification of steel sections only

Steel girders of the unshored composite girders need to carry the dead loads such as own weight, the weight of frame works, the weight of wet concrete, etc., until the concrete hardens. In such case, safety of the steel girders should be verified by confirming Eq.(15.2.1) to become not greater than 1.0 while the following figures are used: M_{sd} by the first phase dead load, and M_{rd} by the steel girder only. In addition, safety against the buckling of a flange or a web, and lateral or lateral-torsional buckling of steel girders in the construction stage shall be ascertained in accordance with Chapters 5 and 6.

(2) Verification of composite sections

For the verification to composite sections, such factors shall be appropriately considered as the dead load, the live load, the effect of the construction sequence (history of given load), shrinkage and creep of the concrete, and temperature difference between the concrete deck and the steel girders, etc.

When the bending strength is calculated by plastic theory for compact sections, such points can be neglected as the effect of the construction sequence, shrinkage and creep of concrete, and temperature difference between the concrete deck and the steel girders, because the verification is done against the plastic stress state. By contraries, these points shall be appropriately taken into account when the bending strength is calculated by elastic theory for noncompact or slender section, because the verification is done against the elastic stress state.

15.2.4 Shear strength

The design shear strength of a composite girder is equal to that of the steel girder used in the composite girder.

【 Commentary 】

Although contribution by the floor deck on shear strength is expected, it is decided not to take account for safety margin. Shear strength V_r of the steel girder can be calculated with Eq.(C15.2.12)

[Basler, 1961] ;

$$\frac{V_r}{V_y} = \frac{\tau_{cr}}{\tau_y} + \frac{\sqrt{3}}{2} \frac{1 - \tau_{cr}/\tau_y}{\sqrt{1 + \alpha^2}} \quad (\text{C15.2.12})$$

where τ_{cr} is shear buckling stress, τ_y is yield shear stress, $V_y = \tau_y h_w t_w$ is yield shear strength, h_w is web depth, t_w is web thickness, α is aspect ratio (≤ 3.0). Web shear buckling strength τ_{cr} ($\leq \tau_y$) is calculated as follows;

$$\tau_{cr} = \begin{cases} \tau_e & (\tau_e \leq 0.8\tau_y) \\ \sqrt{0.8\tau_e\tau_y} & (\tau_e \geq 0.8\tau_y) \end{cases} \quad (\text{C15.2.13})$$

$$\tau_e = k_s \frac{\pi^2 E}{12(1 - \nu^2)} \left(\frac{t_w}{h_w} \right)^2 \quad (\text{C15.2.14})$$

where k_s is to be calculated as follows

$$k_s = \begin{cases} 5.34 + 4.00/\alpha^2 & (\alpha \geq 1) \\ 4.00 + 5.34/\alpha^2 & (\alpha \leq 1) \end{cases} \quad (\text{C15.2.15})$$

In Eq.(C15.2.12), the first term in the right hand side is shear buckling strength and the second term is strength of the post-buckling due to diagonal tension field. At the ends of girders, arranging rigid vertical stiffeners is required by Specifications for Highway Bridges [JRA 2003], because the post-buckling strength cannot be always expected. When one horizontal stiffener is provided to the web, the sum of shear strength of each panel (upper and lower of the stiffener) calculated by Eq.(C15.2.12) is to be shear strength of the stiffened web.

15.2.5 Verification of shear

At the safety limit state, the section shall satisfy the following equation:

$$\gamma_i \frac{V_{sd}}{V_{rd}} \leq 1.0 \quad (15.2.2)$$

where , V_{rd} : Design shear strength , V_r/γ_b
 V_{sd} : Design shear moment
 γ_i : Structural factor

【 Commentary 】

The way of safety check against shear failure is given.

15.2.6 Verification of combined bending and shear

When bending moment and vertical shear force simultaneously act on a composite girder, the combined action due to these forces shall be considered.

【 Commentary 】

When a composite girder is subjected to a combination of a large bending moment and a large shear force, it is necessary to verify not only the action of each force individually but also the combined effect of the forces.

Design Standards for Railway Structures and Commentary [RTRI, 2000] gives the following quadratic

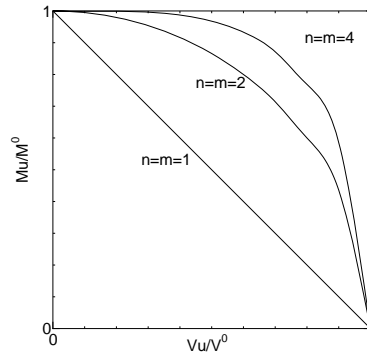

Fig.C15.2.6 Shear-moment interaction diagram

equation for plate girders and similar structures. This equation is based on Mises' yield condition and also takes into account post-buckling strength in the diagonal tension field and the combined stresses are taken. The strength amplification factor is reduced according to past experience.

$$\left(\frac{\gamma_a \gamma_b \gamma_i}{1.1}\right)^2 \left\{ \left(\frac{M}{M_r}\right)^2 + \left(\frac{V}{V_r}\right)^2 \right\} \leq 1 \quad (\text{C15.2.16})$$

where, M, V : applied bending moment and applied shear force
 M_r, V_r : bending strength and shear strength
 $\gamma_a, \gamma_b, \gamma_i$: partial factors

Furthermore, the 4th-order Eq.(C15.2.17) is adopted for recently developed two-main-girders bridges (such as the Chidori-no-sawakawa Bridge).

$$(1.7)^4 \left\{ \left(\frac{M}{M_r}\right)^4 + \left(\frac{V}{V_r}\right)^4 \right\} \leq 1 \quad (\text{C15.2.17})$$

In the above two equations, V_r may be replaced by the sum of shear buckling strength and strength due to the diagonal tension field. However, this brings up the question of how the partial factors and the strength in the diagonal tension field can be evaluated. Further, attention is necessary for consistency with the rules about vertical stiffener spacings given in Highway Bridge Specifications [JRA, 2002] when this 4th-order equation is used.

There are many studies covering the evaluation of bending strength, ultimate shear strength, and strength against combined bending and shear force for web plates with vertical stiffeners only. In particular, various correlative equations have been proposed by Basler et al. for combined ultimate strength against bending and shear. Currently, the following power sum correlation is considered effective as a relatively simple design equation:

$$\left(\frac{M_u}{M_u^0}\right)^n + \left(\frac{V_u}{V_u^0}\right)^m = 1.0 \quad (\text{C15.2.18})$$

where, M_u, V_u : ultimate bending strength and ultimate shear strength
when both are simultaneously loaded
 M_u^0, V_u^0 : ultimate bending strength and ultimate shear strength
when either one is loaded
 m, n : arbitrary constants

Figure C15.2.6 shows moment-shear interactions for $m = n = 1, 2,$ and 4 . As m and n are increased, the interaction between bending and shear is drastically reduced.

The natural properties of a girder are that bending moment is resisted mainly by the flanges while shear force is resisted by the web plate. In this respect, it is considered that the above interaction curves at or around $m = n = 4$ well represent the behavior of a composite girder. If appropriate factors were to be sought by collecting test data and/or by exact numerical calculation results, there is a high possibility that new interaction equations may become available as design tools, possibly using different values of n and m .

15.3 Structural Analysis and Resultant Force

Linear elastic analysis shall basically be used for structural design of composite girders. In the case of continuous composite girders, tensile cracks may take place in the concrete deck near intermediate supports, accordingly resultant forces shall be calculated with consideration of the reduction of the stiffness caused by these cracks. When the full plastic bending moment is expected as the bending strength, attention must be paid to the redistribution of the resultant forces associated with the inelastic behavior.

【Commentary】

At the safety limit state of a composite girder, plastic region is widely spread into the girder, and the stress resultant is accordingly redistributed. This phenomenon can be solved by nonlinear analysis, though this is not necessarily preferable at practical design stage due to its complexity. In this chapter, the maximum bending strength of girder is to be restricted up to Class 2 section defined in Eurocode, whose strength is equal to the plastic moment, and thus the elastic analysis can be used while attentions are paid to the redistribution of stress resultant.

On the other hand, Class 1 section corresponds to rolled steel sections which have relatively large plate thickness compared with the size of section, and its ultimate state usually becomes unstable mechanism in which plural hinges are formed inside the structure. Such case requires the plastic analysis, but its design is often governed by the serviceability limit or the fatigue limit state instead of the safety limit state.

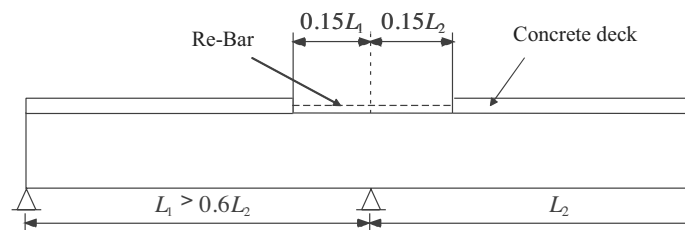

Fig.C15.3.1 Section to decide moment of inertia around intermediate support

At intermediate supports, the concrete cracks produce, and the flexural rigidity depends on cracking state which is influenced by load intensity and loading pattern. Exact evaluation of flexural rigidity at the section is thus difficult. Though several propositions on defining method for the flexural rigidity have been available [Johnson et.al., 1998], this specification requires the moment of inertia for deciding flexural rigidity to be calculated from the cross section that is composed of the steel girder and re-bars both which are located in 15% length of each span neighboring the intermediate support as being shown in Fig.C15.3.1.

15.4 Shear Connectors

15.4.1 General

- (1) Shear connectors arranged at the interface of the concrete deck and steel girders shall be verified to satisfy required performances.
- (2) Shear connectors shall be properly designed for both safety limit state and fatigue limit state in order to ensure sufficient structural performance throughout the design working life.
- (3) Shear connectors shall have sufficient deformation capacity enabling to redistribute the horizontal shear force between the concrete and the steel to wider area, because this redistribution can occur at the safety limit state
- (4) When two or more different types of shear connector are used within the same span of a composite girder, influence by the difference on shear force versus slip relationship shall be adequately considered.

【Commentary】

- (1) and (2) Shear connectors are important structural members indispensable for the composite girder, and accordingly they shall be designed sufficiently safe against each limit state. In particular, it is necessary to understand type, size and frequency of the acting force, and the transmission mechanism of the force by the shear connectors shall be clearly grasped. When the transmitting force and the mechanism are not clear, suitable experiment or detailed analysis etc. are needed to decide structure of the shear connectors and thus to confirm their safety.

So far, the shear connectors of composite girders are designed only against the horizontal shear force in the longitudinal direction. In the case of composite minimized-number of main girders bridge, however, transverse load such as earthquake or wind has stronger influence than the longitudinal load in terms of the design load for shear connectors arranged near supports. The load, accordingly, often governs design, because the transverse load is transmitted from the concrete deck to cross beam at the support and then to the shoes.

Moreover such bridges usually have wide distance between the main girders, and the shear connectors arranged around the internal cross beams may receive pullout force due to rotation of the concrete deck which is caused from the second phase dead load, the prestress and live load [Sakai, et al. 1995, 1997]. The shear connectors arranged this portion, therefore, must be designed against not only the horizontal shear force in the longitudinal direction but also the force in the transverse direction as well as the pullout force. As for evaluation of design strength of the stud simultaneously receiving plural forces, a reference [Ohtani, et.al, 1994] is available. Eurocode[CEN, 2002] requires a special consideration when shear connectors are given the pullout force being larger than 1/10 of their tensile strength.

- (3) It is one method that some shear connectors are allowed to enter elastic state but safety and performance of the structure are secured by whole group of connectors. However, it is necessary to confirm the safety when allowing the elasto-plastic behavior of the shear connectors over total span of the main girder is intended.

15.4.2 Type of shear connectors

- (1) Shear connectors are devices provided at the interface between the steel element and the concrete deck in order to resist internal shear.
- (2) Shear connectors shall be mechanical devices that join the steel and the concrete. However, other types of shear connector can be used as long as their safety is verified in proper ways.

【 Commentary 】

- (1) This chapter describes a composite girder bridge where the concrete deck is united with the shear connectors to the upper surface of the flange of steel girder. The shear connectors in a composite structure are jointing devices to integrate both steel and concrete, and in this sense, steel members or a part of them both buried into the concrete like steel framed concrete structures belong to the shear connectors. However, it is necessary for designing the share connectors of the composite structure to distinguish the differences in dynamic behavior, fatigue characteristic, etc. of them from those of the burial type.
- (2) The shear connectors are classified into (a) mechanical joint, (b) friction bonding, (c) adhesion, and (d) adhesives, each which contains the following methods.
 - (a) (a)Mechanical joints: Stud (High strength stud [Eguchi,et.al.1999]), Cupler-joint stud [Ishikawa,et.al.2001], High-rigidity stud [Hiragi,et.al.2001], Delayed-composite stud [Kitagawa,et.al.2001], Shape steel, Block dowels, Perforated-plate dowels and Angle-connector.
 - (b) Friction type joint: High tensile bolt.
 - (c) Adhesion type joint: Protrudent rolled steels (checkered steel plate, rugged-surface H-shape steel).
 - (d) Bonding type joint: Epoxy resin.

Among these, mechanical joints have been overwhelmingly used because high composite effect can be expected even with small contacting area. In this specification, mechanical joints are regarded as the prime shear connectors for composite girder bridges based on domestic and foreign researches and the construction experiences.

In road bridges, the headed stud connectors have been very widely applied, because they are excellent in construction easiness and high economy. For railway bridges, shear connectors called block dowels are generally used. This type of connector consists of a steel block or a horseshoe-shape plate to which a semicircle re-bar is welded. This re-bar prevents the deck from lifting up. Other than the headed studs and block dowels, there are perforated-plate dowels [Leonhalt,1987] and angle-connector which unifies the flange plate and concrete deck in corrugated steel-web bridges [Igase,et.al.2002].

On the other hand, connection methods other than mechanical joints, such as high tension bolts, are used for precast concrete deck panels. The adhesion type joint and the bonding type joint have no record of being solely used, though the adhesion type joint and the friction connector with high tensile bolts are recently studied for practical use[Uenaka,et.al.1998; Tokumitsu,et.al.1998]. However, the adhesion type joint keeps the connection only at the interface between the steel and concrete, this type thus has an anxiety of durability that peeling from the interface of the concrete may precede when only this type connectors are used.

In the case of a composite minimized-number of main girders bridge, arrangement of connectors might face difficulty because too many connectors are needed per one main girder when only mechanical joints are used. This tendency will be remarkable for the case of precast deck panels, because the location for the shear connectors to be arranged is restricted. If a mechanical joint is going to be used, one method of easy arrangement is use of the group studs for instance. As for other methods, using mechanical joints or friction joints together with the adhesion type joints or the bonding type joints can be effective, though such idea needs a lot of studies in the future.

15.4.3 Ultimate limit state for shear connectors

Safety and durability of the shear connectors shall be verified against the safety limit state and the fatigue limit state, respectively. The ultimate load shall be applied to the former, while the service load shall be used to the latter.

【 Commentary 】

Safety and durability are considered as required performances associated with shear connectors. The safety limit state and fatigue limit states are selected to represent these required performances.

15.4.4 Verification at safety limit state

At the safety limit state, shear connectors shall satisfy both of the following equations:

$$\frac{1}{1.1} \left(\gamma_i \frac{q_{sd}}{q_{rd}} \right) \leq 1.0 \tag{15.4.1}$$

$$\gamma_i \frac{Q_{sd}}{Q_{rd}} \leq 1.0 \tag{15.4.2}$$

- where , q_{sd} : Horizontal design shear force per unit length
- q_{rd} : Horizontal design shear strength per unit length
- Q_{sd} : Total horizontal design shear force over a longitudinal length where the size, type, and spacing of shear connectors are kept same
- Q_{rd} : Total horizontal design shear strength over the same length
- γ_i : Structural factor. For a standard structure, taken to be $\gamma_i = 1.0$.

【 Commentary 】

In this specification, plastic deformation of shear connectors is allowed at the safety limit state, so similar to Eurocode, q_{sd} can exceed q_{rd} by 10% as shown in Fig.C15.4.1. In this case, local slip deformation between the steel girder and the concrete deck occurs. However, when Q_{sd} does not exceed Q_{rd} for each longitudinal length (L_{ab}) where the type and configuration of shear connectors are kept unchanged as shown in Fig.C15.4.1, the section is judged to possess adequate flexural capacity as a composite section. Hence, Eq.(15.4.1) and Eq.(15.4.2) are employed to check the safety limit state for shear connectors. To exert the full flexural capacity as a composite section in such cases, it is necessary that the shear connectors have sufficient deformation capacity as pointed out at 15.4.1(3).

The boundary of L_{ab} can be taken at such points that the type and pitch of the shear connector are changed, inflection points where the bending moment becomes zero and points where the maximum or minimum bending moment is generated.

Q_{sd} can be calculated as the difference between the axial forces N_a and N_b in concrete deck (a and

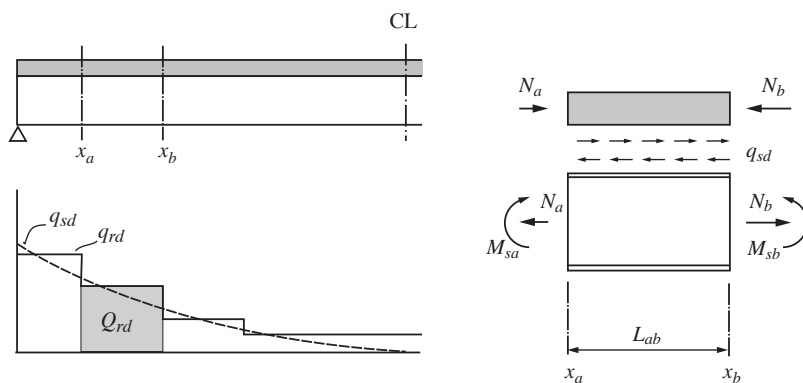

Fig.C15.4.1 Horizontal design shear force and design strength

b are arbitrary two sections in the deck).

$$Q_{sd} = N_b - N_a = \int_{x_a}^{x_b} q_{sd} dx \quad (C15.4.1)$$

On the other hand, Q_{rd} can be calculated from

$$Q_{rd} = n_{ab} V_{ud} \quad (C15.4.2)$$

where Q_{rd} is the number of the shear connectors installed within L_{ab} , and V_{ud} stands for the design shear strength of one connector.

15.4.5 Verification at fatigue limit state

At the fatigue limit state, shear connectors shall satisfy the following equation:

$$\gamma_i \frac{V_{sd}}{V_{rd}} \leq 1.0 \quad (15.4.3)$$

where , V_{sd} : Fluctuation of design shear force acting on an individual shear connector or one group of the connectors.

V_{rd} : Allowable fluctuation of the design shear strength against fatigue.

γ_i : Structural factor

【 Commentary 】

V_{rd} of a stud is written as V_{sd} in Eq.(C15.4.5) and Eq.(C15.4.6) in the commentary of 15.4.6.

15.4.6 Design strength of shear connectors

This clause covers rules regarding the design shear strength of (1) headed stud connectors, (2) perforated-plate dowels (perforated ribs), and (3) block dowels. Use of the other types of shear connector is of course allowed, but the design strength shall be properly determined through experiment or other methods.

15.4.6.1 Design shear strength of headed studs

- (1) The design strength of headed studs shall be determined by using appropriate methods with consideration of the casting direction of the concrete for the deck.
- (2) When headed studs are subject to tensile force as well as shear force and when the influence of the tensile force is not negligible, a more accurate method enabling to consider the tensile force shall be used.
- (3) When headed studs are arranged in groups, influence of the grouped arrangement shall be taken into consideration by appropriate method(s).

【 Commentary 】

- (1) It is well known that casting direction of concrete affects the shear strength of connector. As being shown in Fig.C15.4.2, casting direction of the concrete associated with the structural system is classified into 4 types, namely, type A: composite bridges, type B: lower flange of corrugated steel-web bridges, type C and D : steel-RC mixed girder bridges or composite piers.

The design shear strength of a headed stud shall preferably be calculated by the following equations given in Manual for Verification of Performance of Hybrid Structures [JSCE, 2002].

- Safety limit state (Type A, B, C, D)

The following two equations whichever generates a smaller value.

$$V_{sud} = (31A_{ss}\sqrt{(h_{ss}/d_{ss})f'_{cd}} + 10000)/\gamma_b \quad (\text{C15.4.3})$$

$$V_{sud} = A_{ss}f_{sud}/\gamma_b \quad (\text{C15.4.4})$$

However, $h_{ss}/d_{ss} > 4$.

where, V_{srd} : design shear strength of the stud (N), A_{ss} : area of the shank of the stud (mm^2), d_{ss} : diameter of the shank of the stud (mm), h_{ss} : height of the stud (mm), f'_{cd} : design compressive strength of concrete (N/mm^2) ($=f'_{ck}/\gamma_c$), f'_{ck} : the characteristic compressive strength of concrete (N/mm^2), f_{sud} : design tensile strength of the stud (N/mm^2) ($=f_{suk}/\gamma_s$), f_{suk} : characteristic tensile strength of the stud (N/mm^2), γ_c : material factor of concrete ($=1.3$), γ_s : material factor of the stud ($=1.0$), γ_b : member factor ($=1.3$).

• Fatigue limit state

$$\text{(Type A, C, D)} \quad V_{srd}/V_{su0} = 0.99N^{-0.105} \quad (\text{C15.4.5})$$

$$\text{(Type B)} \quad V_{srd}/V_{su0} = 0.93N^{-0.105} \quad (\text{C15.4.6})$$

where,

$$V_{su0} = (31A_{ss}\sqrt{(h_{ss}/d_{ss})f'_{ck}} + 10000)/\gamma_b$$

where, V_{srd} : design shear strength of the stud for fatigue (range of fluctuation) (N), N : fatigue life or equivalent number of repeating cycles of load, γ_b : member factor ($=1.0$).

Most design of the headed stud connectors in Japan is done in accordance with the Highway Bridge Specification [JRA 2002]. However, the design shear strength of the headed studs described here is only for the serviceability limit state because this specification is based on the allowable stress design method. In addition, application of the minimized-number main girders bridge is not necessarily intended in this specification.

The equations of Eq.(C15.4.3) - Eq.(C15.4.6) are obtained through multivariable linear regression analyses on the typical push-out test data [Hiragi, et al, 1989]. The correlation coefficients for the static strength and the fatigue strength are relatively high as 0.894 and 0.795, respectively. The applicable range of the equations Eq.(C15.4.3) and Eq.(C15.4.4), which are valid for all the types of A to D for; the diameter of the shank of stud is 13–32 mm; the height of the stud is 50–210 mm; the tensile strength of stud is 402–549 N/mm^2 , and the design compressive strength of concrete is 14–63 N/mm^2 . The applicable range of the equations Eq.(C15.4.5) and Eq.(C15.4.6) for; the diameter of shank of stud is 13–22 mm; the height of stud is 60–150 mm; the tensile strength of stud is 402–549 N/mm^2 ; and the design compressive strength of concrete is 20–55 N/mm^2 .

Neighboring sections of an intermediate support of composite continuous girders are subjected to repeated negative bending moment due to the traffic load, accordingly the fatigue strength of the steel flange having welded studs was found to decrease in proportion to the shear force acting on the studs [Kajikawa et al., 1985]. It is therefore desirable to reduce suitably the fatigue strength of the headed studs which are calculated by Eq.(C15.4.5) or Eq.(C15.4.6), depending on the magnitude of tensile stress acting in the flange.

For f_{suk} , the lowest value given in specifications (for example, JIS B 1198 Headed studs: $f_{suk} = 400 \text{ N}/\text{mm}^2$) shall be used. And, the member factor for the safety limit state γ_b shall be 1.3 with consideration of complex stress distribution around studs and the structural importance of them.

- (2) Headed studs shall be mainly used to resist the longitudinal and transversal shear force. When the headed studs receive not only the shear force but also the tensile force and when this influence

can not be neglected, additional investigations are needed to decide the design strength of stud, to which references [e.g. Otani et. al, 1994] are available.

- (3) Grouped arrangement of headed studs is useful when, for example, precast concrete deck panels are used in a composite bridge. However, if the studs are arranged so closely, reduction of the shear strength per one stud may be induced due to overlapping of the concrete stress near the studs. In this case, a suitable reduction factor to be used in Eq.(C15.4.3) - Eq.(C15.4.6) must be determined while taking this influence into account. References [e.g. Okada et. al, 2006] can be used for this evaluation.

The following points should be considered for application of the grouped arrangement of headed studs.

- Non-uniform distribution of the longitudinal shear force.
- Possibility of slip or separation between the concrete deck and the steel girder.
- Buckling of the steel flange.
- Local failure of the concrete deck due to high concentrated forces acting on the grouped studs.
- In the case of precast concrete deck panels, shape of holes for installing the grouped studs, the distance between the side face of a hole and the shank of studs, etc. [Kurita et al, 2005].

15.4.6.2 Design shear strength of perforated-plate dowels

- (1) The design shear strength of the perforated-plate dowels shall be separately evaluated for the two cases by suitable way(s); one is that transverse re-bars run through a perforations and the other is that transverse re-bars do not run through.
- (2) The shear strength of a perforated steel plate itself shall be greater than the whole strength as a shear connector.

【 Commentary 】

- (1) In perforated-plate dowels, the shear force is resisted with the portion of concrete filled into holes of the perforated steel plate as if the portion acts like shear connectors. The horizontal shear force acting to the interface of the steel and the concrete deck is supported as the bearing stress of the concrete, and the steel plate which receives the reaction from concrete transmits the force to entire steel girder through the fillet welding between the plate and girder.

The design shear strength of perforated-plate dowels for the ultimate state may be calculated

Type	Direction of concrete casting
A	
B	
C	
D	

Fig.C15.4.2 Classification of headed studs depending on concreting irection

by the following equations:

(a) For perforated-plate dowels without transverse re-bars:

$$V_{aud} = \left\{ 3.38d^2 \left(\frac{t}{d} \right)^{1/2} f'_{cd} - 121 \times 10^3 \right\} / \gamma_b \quad (\text{C15.4.7})$$

with the application limit as the followings based on experimental parameters:

$$35.8 \times 10^3 < d^2 \left(\frac{t}{d} \right)^{1/2} f'_{cd} < 194.0 \times 10^3 \quad (\text{C15.4.8})$$

where d is the diameter of a perforation (mm), t is the thickness of the perforated steel plate (mm), f'_{cd} is the design strength of concrete (N/mm²).

(b) For perforated-plate dowels with transverse re-bars:

$$V_{aud} = [1.45 \{ (d^2 - \phi_{st}^2) f'_{cd} + \phi_{st}^2 f_{st} \} - 106.1 \times 10^3] / \gamma_b \quad (\text{C15.4.9})$$

with the application limit as the followings based on experimental parameters:

$$73.2 \times 10^3 < (d^2 - \phi_{st}^2) f'_{cd} + \phi_{st}^2 f_{st} < 488.0 \times 10^3 \quad (\text{C15.4.10})$$

where ϕ_{st} and f_{st} are the diameter (mm) and the tensile strength (N/mm²) of the re-bar. The member factor γ_b can be 1.3.

Two equations Eq.(C15.4.7) and Eq.(C15.4.9) present design shear strength at the safety limit state for the two kinds of perforated-plate dowels [Hosaka, et.al. 2000]. These equations are obtained by a regression analysis of the logarithm type that puts experimental data of the studies into the Leonhardt's equation [Leonhardt, 1987]. Eq.(C15.4.7) is with consideration of thickness-diameter ratio (t/d), and Eq.(C15.4.9) takes the diameter as well as the tensile strength of re-bars into consideration besides t/d . The correlation coefficients calculated in statistical processing have high accuracy of 0.971 (without re-bars) and 0.979 (with re-bars), and the curves derived from the equations lowered by two times of standard deviation so that they might cover the scatter of experimental data. However, the applicable range of two equations shall be properly set so as to produce positive value for the design shear strength.

Leonhardt[1987] proposed the equation for such case that no transverse re-bars were arranged, because he considered that this type of share connectors was purely made of concrete, however, experimental studies [Hosaka, et.al. 1998] showed that the maximum shear strength of perforated-plate dowels was improved by arranging the transverse re-bars. The first term in Eq.(C15.4.9) shows the shear strength given as concrete-connectors, and the second term shows the shear strength added by presence of the transverse re-bars. Moreover, the transverse re-bars can increase slipping capability at the contact area between the steel girder and concrete deck, which in turn reduces drop of the post-peak bearing performance and raises the deflection capability.

Although any problems about fatigue of this type connectors used in composite girders have not been reported yet, suitable verifications shall be conducted when necessity of checking fatigue safety of perforated-plate dowels or the welded portions arises.

(2) Shear strength of the perforated steel plate between one hole to another can be calculated in accordance with [Leonhardt, 1987]:

$$V_r = \frac{100}{60} \frac{\sigma_y}{\sqrt{3}} A_s \quad (\text{C15.4.11})$$

where, V_r : Shear strength of the perforated steel plate (N), A_s : Cross-sectional area of the plate between two holes (mm²), σ_y : Yield strength of the steel plate (N/mm²).

The design shear strength of the steel plate calculated from Eq.(C15.4.11) shall exceed the design shear strength V_{sd} of perforated-plate dowels calculated in (1), and shall be verified with the following equation.

$$\gamma_i \frac{V_{sd}}{V_{rd}} \leq 1.0 \quad (V_{rd} = \frac{V_r}{\gamma_b}) \quad (\text{C15.4.12})$$

When the perforated-plate dowels are used in restrained concrete like inside a steel cell, etc. where rise of the shear strength can be expected, proper examination to calculate real strength is needed.

15.4.6.3 Design shear strength of block dowels

The design shear strength of block dowels shall be evaluated in proper way(s).

【Commentary】

Design strength of block dowels for the safety limit state can be calculated with the equation Eq.(C15.4.13) or Eq.(C15.4.14) whichever yields smaller value when consideration of the fatigue is not needed, and can be determined with Eq.(C15.4.15) when consideration of the fatigue is needed.

a) When considerations of the fatigue is not needed:

$$V_{bud} = (f_{bud}A_1 + 0.7f_uA_2/\gamma_s)/\gamma_b \quad (\text{C15.4.13})$$

$$V_{bud} = (f_{bud}A_1 + 30\phi B/\gamma_c)/\gamma_b \quad (\text{C15.4.14})$$

where, V_{bud} : Design shear strength of block dowel without consideration of the fatigue (N).

$f_{bud} = \eta f'_{ck}/\gamma_c$: Design bearing strength of the concrete in front of the block dowel (N/mm²),

here ,

$$\eta = \begin{cases} 1.1 & (A \geq 4A_1) \\ 0.55\sqrt{A/A_1} & (A < 4A_1) \end{cases}$$

A_1 : Effective bearing area of a block dowel (mm²).

A_2 : Cross sectional area of semicircle re-bar which is diagonally fixed to block (mm²).

$$A = \begin{cases} 2h_0^2 & (\text{for deck without haunch}) \\ b_0h_c & (\text{for deck with haunch}) \end{cases}$$

h_0 : Thickness of the deck (mm).

h_c : Distance between the upper surface of steel flange and the upper surface of deck (mm).

b_0 : Width at the lower end of haunch where the steel flange and concrete deck meet (mm).

f_u : Characteristics tensile strength of the steel (N/mm²).

ϕ : Diameter of semicircle re-bar which is diagonally fixed to block (mm).

B : Width of the block (mm).

γ_c : Material factor for concrete, and can be generally set to 1.3.

γ_s : Material factor for steel, and can be generally set to 1.0.

γ_b : Member factor, and can be generally set to 1.3.

In both equations of Eq.(C15.4.13) and Eq.(C15.4.14), the first term of the right hand side shows the strength by the block itself, and the second term shows the strength by the semicircle re-bar. Regarding this second term, Eq.(C15.4.13) is for the case when the semicircle re-bar governs the strength, and Eq.(C15.4.14) is derived on condition that the upper limit of bearing strength of re-bars sufficiently embedded into concrete with appropriate cover is considered 30 N/mm^2 .

b) When considerations of the fatigue is needed:

$$V'_{bud} = (f_{bud}A_1)/\gamma_b \quad (\text{C15.4.15})$$

where, V'_{bud} : Fluctuation of design shear strength when considerations of the fatigue is needed (N)

γ_b : Member factor, and can be generally set to 1.3 .

Portions where fatigue may occur are: (a) welded part between shear connectors and the steel girder, (b) the semicircle re-bar, and (c) the concrete facing shear connectors, among which the part (c) is in mind here. However, contribution by the semicircle re-bar is omitted from Eq.(C15.4.15) because the welded point of the re-bar seems to be vulnerable against cyclic loading.

The clauses and explanations given here follow [JSCE, 2002], but its original is written in [RTRI, 2000]. The block dowel is combination of a steel block or horseshoe-shaped steel plate and a semicircle re-bar, and this type of shear connectors has been widely used in railway structures.

The slip of block dowel between the steel girder and concrete is small under ordinary service condition, so verification for the service limit state is not generally required. However, the performance of this type of shear connectors differs depending on direction, which heterogeneous effect is not observed in the headed stud connectors. The verification equations shown here are for the longitudinal (along the bridge axis) horizontal shear force, and thus they are not directly applicable to the transverse (perpendicular to the bridge axis) horizontal shear.

15.4.7 Influence of steel girder plasticity on horizontal shear force

If the steel girder shows plastic behavior at the safety limit state, the horizontal design shear force acting the connectors within this plastic zone shall be properly determined with consideration of this influence.

【Commentary】

When design is made on so-called compact section in which some portion inside the steel girder enters the plastic range, it should be noted that the distribution of horizontal shear differs from one obtained with the linear elastic analysis because of this influence. The total horizontal shear force from x_a to x_b section can be a difference of the axial force N_a and N_b of the concrete deck as shown in Fig.C15.4.3. In this example, the axial force N_a is calculated from conventional elastic beam theory since the section at x_a is assumed to be elastic. When the section at x_b is full plastic, then the axial force of the concrete deck can be obtained easily, but calculating the axial force is not easy when the section at x_b is partially plastic. In this case, N can be decided as the corresponding point to an arbitrary M on the line shown in Fig.C15.4.3 which linearly connects the initial yielding state (N_y, M_y) and the full plastic state (N_p, M_p).

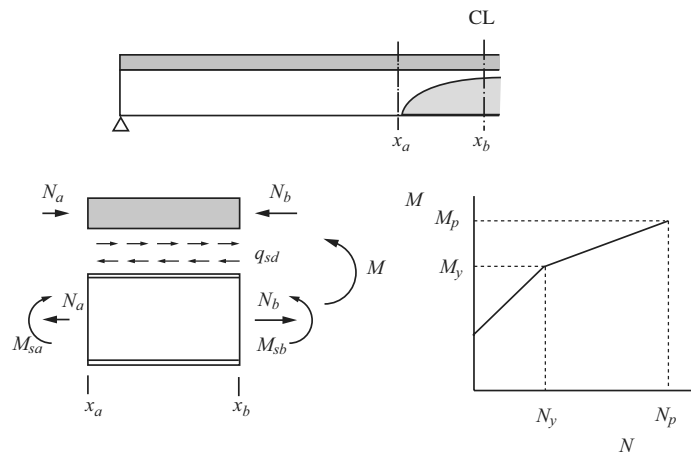

Fig.C15.4.3 Relationship between bending moment and axial force of concrete deck

15.5 Detailing of Shear Connectors

15.5.1 Headed stud connectors

- (1) The standard shank diameter shall be 19mm or 22mm. For determination of material properties, types, shapes and proportions, it is desirable to obey JIS B 1198 Headed stud connectors.
- (2) The maximum spacing of headed stud connectors shall be determined so that the required performance as the shear connectors may be satisfied while preventing occurrence of buckling of the flanges of the girders and other undesirable behaviors.
- (3) The minimum spacing of headed stud connectors shall be determined so that the required performance as the shear connectors may be satisfied while allowing easy work execution and preventing generation of harmful cracks in the concrete deck.
- (4) The distance between the shank surface of a headed stud connector and the edge of the girder flange shall preferably be greater than 25mm.
- (5) In a composite minimized-number main girders bridge, headed stud connectors shall be arranged with consideration of not only longitudinal shear force but also transverse shear force as well as tensile force.
- (6) Cross section of the concrete deck near headed stud connectors shall have sufficient safety against the shear force acting from the connectors.
- (7) Holes provided in precast concrete deck panels for installing the shear connectors shall have appropriate details to enable doing easy work as well as avoiding local failure.

【 Commentary 】

- (1) Based on actual experiences in design and construction, a standard diameter of the shank is decided 19mm or 22mm. Experimental study [JH, 1998] and analytical study [Okada et. al, 2005] on the shear strength of 25mm diameter stud, however, were conducted, and real applications of 25mm diameter studs have been increased. Studs having other diameter than the standard values can be thus used, if the required performance of the stud is properly evaluated by experiments or analyses.
- (2) As for the maximum spacing of the stud, Highway Bridge Specification [JRA, 2002] gives the regulation that the required performance as shear connectors for composite girders can be re-

garded satisfactory when the maximum spacing of the studs is not greater than 3 times of the total thickness of the concrete deck nor 600mm. AASHTO[AASHTO, 2005] sets the maximum spacing to be not greater than 800mm. Eurocode[CEN, 2003] decided the maximum spacing to be not greater than 4 times of the total thickness of the concrete deck nor 800mm and also gave additional restrictions for the class 1 or class 2 section depending on the thickness and the yield strength of the compressive flange in order to prevent buckling.

- (3) As for the minimum spacing of the studs, Highway Bridge Specification [JRA, 2002] gives the regulation that the required performance as shear connectors for composite girders can be regarded satisfactory when the longitudinal minimum spacing is $5d$ (d : diameter of the shank) or 100mm whichever is larger and when the transverse minimum spacing is $d+30$ mm. AASHTO[AASHTO, 2005] sets the minimum longitudinal and transverse spacing to be $6d$ and $4d$, respectively. Eurocode 4[CEN, 2003] decided the minimum longitudinal spacing to be $5d$ and the minimum transversal spacing to be $4d$ for rigid deck and $2.5d$ for other decks. Appropriate design is needed based on these rules.
- (4) This is in accordance with Highway Bridge Specification [JRA, 2002], AASHTO[AASHTO, 2005] and Eurocode 4[CEN, 2003].
- (5) In a composite minimized-number main girders bridge or other similar types of bridges where the width of deck is large; elimination of the lateral bracings and simplification of the cross girders are often done, studs should be suitably arranged with consideration of the transverse force and the tensile force which are induced by wind, earthquake, prestress, traffic load and so on.
- (6) A cross section of the deck near the studs where local shear failure may happen, it is necessary to check if adequate safety against the shear force acting on the headed studs is secured or not. If needed, supplementary reinforcement should be arranged there. The head of a stud should be generally embedded in main part of the concrete deck (instead of the haunch) deeper than 50mm in order to exert enough anchoring effect.
- (7) The shear holes provided in a precast deck panel shall have appropriate detail to allow easy concreting work, and attention is also needed about the concrete property to be cast in-situ. For example, the size of shear holes shall be large enough to accommodate the grouped studs and to compact concrete properly. Moreover, adequate reinforcement should be arranged to prevent from local failure of the concrete at or near the shear holes.

15.5.2 Perforated-plate dowels

- (1) The thickness of a perforated steel plate and the diameter of the re-bars running through the perforations shall be properly determined.
- (2) The diameter of the perforations shall be properly determined with consideration of compaction work and bleeding of the concrete.
- (3) The maximum longitudinal spacing of two adjacent perforations shall be determined so as to satisfy the required performance as the shear connectors.
- (4) The concrete cover over the perforated-plate dowels shall be sufficient value.
- (5) When two or more perforated steel plates are installed in parallel, sufficient transverse spacing shall be secured.
- (6) Details of the perforated-plate dowels shall be determined with sufficient consideration of fatigue.

【 Commentary 】

- (1) Perforated-plate dowels shall have enough strength against the bearing stress from concrete and, be preferably thicker than 12mm which is considered necessary by previous experiences in order to

induce shear failure of the concrete. In addition, the standard diameter of transverse re-bars is to be 13mm, because the re-bars must resist not only the horizontal shear force but also lifting up of the concrete deck. The steel portion of perforated-plate dowels placed in even compressive stress zone is basically free from occurrence of buckling due to confinement given from the concrete.

- (2) The diameter of the hole should preferably be more than the value equivalent to the diameter of transverse re-bars plus the maximum aggregate size.
- (3) The center-to-center spacing of perforations is desirably small as much as possible to transmit the shear force smoothly, but 500mm or less that corresponds to 2.5 times of the minimum deck thickness is regarded as a standard. In the case of larger spacing more than 500mm, enough reinforcement around the perforated-plate dowels is needed.
- (4) The cover from the top surface of concrete to the upper edge of perforated steel plate is preferably more than 100mm. When the cover is thin, concrete bearing strength in front of the dowels and whole strength as shear connector will be reduced.
- (5) When two or more perforated steel plates are arranged in parallel, their spacing is preferably wider than the value of about three times of the height of plate, as the experimental result [Hosaka, et.al, 2002] concluded that two shear connectors arranged in this manner did not influence each other and the concrete in-between worked effectively.
- (6) Basically, perforated-plate dowels have high fatigue resistance [Taira, et.al, 1997]. It is necessary to secure suitable distance from the bottom of perforations to the bottom of concrete deck for sake of keeping welding quality of the perforated-steel plates and the upper flange of girder and avoiding generation of the fatigue cracks from the perforations. Especially when the perforations are provided in very large tensile stress zone, verification about fatigue of the main body as well as the welded portion of the perforated-plate dowels is to be done.

It has been recently known that arrangement of two or more perforated-plate dowels in parallel, instead of only one just above the web of girder, is effective to raise the fatigue resistance when the horizontal shear and uplifting force simultaneously act [Hosaka, et.al, 2002].

15.5.3 Block connectors

- (1) In block dowels having a semicircle re-bar, the angle between the re-bar and the upper surface of steel flange shall generally be 45 degrees.
- (2) The standard thickness of steel plate and the diameter of a re-bar used in block dowels shall be at least 16mm.
- (3) Any shear connectors that may induce a wedge action to the concrete deck are not allowed.

【 Commentary 】

These clauses are quoted from [RTRI, 2000].

15.6 Verification of Crack Width in Composite Girders

Crack width in the concrete deck due to composite action with a steel girder and crack width due to local bending caused by the wheel load shall satisfy the following equations:

$$\gamma_i \frac{w_{md}}{w_a} \leq 1.0 \quad (15.6.1)$$

$$\gamma_i \frac{w_{bd}}{w_a} \leq 1.0 \quad (15.6.2)$$

where , w_a : Design critical value of crack width
 γ_i : Structural factor; for standard structures $\gamma_i = 1.0$

【 Commentary 】

(1) Design critical value of crack width

The design critical value of crack width for concrete decks shall be determined with consideration of environmental condition as well as a type and presence or absence of waterproof layer in the concrete deck. If no special investigation about the critical crack width is carried out, the value given in Concrete Standard Specification [JSCE, 2002] may be used. The critical crack width is given there as a function of environmental conditions and cover C .

(2) Crack width due to main girder effect

There are several methods to calculate the crack width of a concrete deck as shown in [JSCE, 2002], [CEB/FIP-90,1993], [Hanswille, 1996, 1997] and [Nagai et.al, 2002]. The calculation method proposed by Nagai et al. [2004] taking the initial crack state into account will be explained below.

The design crack width w_{md} is given in term of the negative design bending moment for crack width calculation M_d :

$$w_{md} = \begin{cases} w_{CR} + \frac{w_{ER} - w_{CR}}{M_{ER} - M_{CR}}(M_d - M_{CR}) & (M_{CR} \leq M_d \leq M_{ER}) \\ w_{ER} & (M_{ER} \leq M_d) \end{cases} \quad (C15.6.1)$$

where M_{CR} is the negative bending moment at initial cracking, and M_{ER} is the negative bending moment at the boundary from the initial crack state to the stabilized crack state. The initial crack width w_{CR} and stabilized crack width w_{ER} are obtained as follows.

a) Initial crack width

$$w_{CR} = L \left(\frac{N_{CR}}{E_s A_s} - \frac{\beta_m N_{CR}}{E_s A_s} - \epsilon_{csd} \right) \quad (\beta_m = 0.60) \quad (C15.6.2)$$

where $N_{CR} = \sigma_m(1 + n\rho_s)A_c$ is the axial force of a concrete deck at initial cracking; σ_m stands for the stress at the middle section of the concrete deck; E_s denotes the Young's modulus of steel; A_s and A_c are the cross sectional area of re-bars and the concrete deck, respectively; $n = E_s/E_c$ is the modular ratio; ρ_s is the reinforcement ratio. ϵ_{csd} denotes shrinkage, and may assign to $\epsilon_{csd} = -150\mu$ under normal conditions. The crack spacing in the initial cracking state is given by:

$$L = \frac{\sigma_{sr} 2\phi}{2.7f_{ct}(1 + n\rho_s)} \quad (C15.6.3)$$

where $\sigma_{sr} = N_{CR}/A_s$ and f_{ct} is the tensile strength of concrete, and ϕ is the re-bar diameter.

b) Stabilized crack width

$$w_{ER} = L \left(\frac{M_d}{E_s I_{st}} y_{sr} + \frac{\beta f_{ct}}{E_s \alpha_{st} \rho_s} - \frac{\beta f_{ct}}{E_s \rho_s} - \epsilon_{csd} \right) \quad (\beta = 0.2) \quad (C15.6.4)$$

where $\alpha_{st} = A_{st} I_{st} / A_g I_g$; A_{st} and I_{st} are the area and inertia moment of the steel girder with re-bars respectively; A_g and I_g are the area and inertia moment of the steel girder; y_{sr} denotes the distance between the centroid decided by re-bars as well as the steel girder and the upper re-bars. The mean crack spacing in the stabilized state is:

$$L = 4C + 0.7(C_s - \phi) \quad (C15.6.5)$$

where C is the pure cover of re-bars, and C_s is the pitch of re-bars.

(3) Crack width due to deck effect

$$w_{bd} = L \left(\frac{\sigma_B}{E_s} - \frac{\beta f_{ct}}{E_s \rho_s} - \epsilon_{csd} \right) \quad (\beta = 0.2) \quad (\text{C15.6.6})$$

(4) Minimum reinforcement required from initial cracking stage

The relationship between the crack width and the reinforcement ratio in the initial cracking stage is obtained from Eq.(C15.6.2). The reinforcement ratio is thus led as a function of the crack width as shown in Fig.C15.6.1 on condition that stress gradient within a concrete deck is neglected for simplicity and cracks generation occurs when the stress at the middle section of the concrete deck σ_m becomes the tensile strength of concrete, The approximate minimum reinforcement ratio can be estimated from this figure.

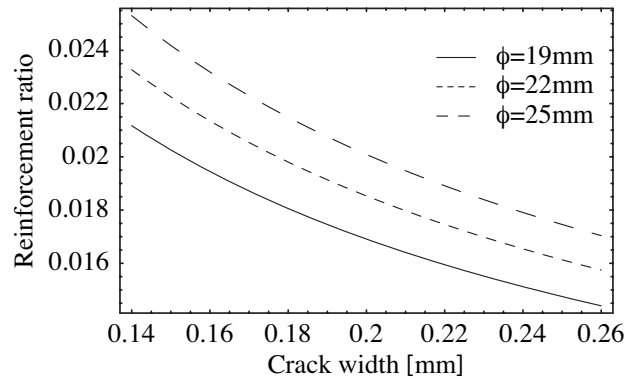

Fig.C15.6.1 Relationship between reinforcement ratio and crack width in initial crack state (concrete tensile strength= 2.5N/mm^2 , $\epsilon_{csd} = -150\mu$)

15.7 Effective Width of Concrete Deck for Composite Girders

Effective width of the concrete deck of composite girders shall be properly determined depending on which limit state is under consideration.

【Commentary】

The effective width given in Specifications for Highway Bridges [JRA, 2002] is based on the linear elastic theory, and the effective width accordingly does not change depending on the magnitude of load. In the limit state design method, however, the effective width may change depending on the corresponding limit states. In the followings, the effective widths for individual limit states will be explained.

(1) Effective width for ultimate limit states

In the ultimate state when the concrete deck for the compact section becomes inelastic, the wider effective width can be expected than that in the elastic stress state owing to inelastic redistribution of stress in the concrete deck. It is possible to estimate the effective width directly by means of FE analyses with consideration of shear-lag effect. Unless a precise analysis such as FEM or experiment is used, the effective width at the ultimate state may be estimated in accordance with Eurocode [CEN, 1997] or AASHTO [AASHTO, 2005].

(2) Effective width for fatigue limit state

The effective described in Highway Bridge Specification [JRA, 2002] may be applied, because the stress condition is nearly assumed to be elastic.

(3) Effective width for crack width calculation

Strain in re-bars in the concrete deck is needed for calculation of crack width in a concrete deck. The effective width B_e is thus defined as the width of the concrete deck for estimation of the maximum strain ε_{max} in the re-bars, and is obtained by integrating the re-bar strain ε_{se} over the transverse width

$$B_e = \frac{1}{\varepsilon_{max}} \int_0^B \varepsilon_{se} ds \quad (C15.7.1)$$

where the definitions of B_e and B are shown in Fig.C15.7.1.

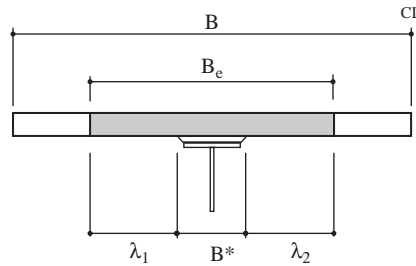

Fig.C15.7.1 Definitions of effective width B_e and total width B

An effective width equation Eq.(C15.7.2) [Okui et al., 2005] have been proposed for a standard two I-girders composite bridge under the dead load as well as live load but without consideration of shrinkage of the concrete.

$$\frac{B_{e0}}{B} = 1 - 1.09 \left(\frac{B}{L_e} \right) + 1.57 \left(\frac{B}{L_e} \right)^2 \quad (C15.7.2)$$

for $0.2 < B/L_e < 0.35$, where L_e is the equivalent span length. In this equation, B_{e0} stands for the effective width, in which subscript $e0$ is used to clarify neglecting shrinkage.

Since the effective width varies depending on the strain, a correction equation is also proposed:

$$\frac{B_e}{B_{e0}} = 1.17 - 0.228 \left(\frac{\varepsilon_{max}}{\varepsilon_{cr}} \right) + 0.068 \left(\frac{\varepsilon_{max}}{\varepsilon_{cr}} \right)^2 \quad (C15.7.3)$$

for $1 \leq \varepsilon_{max}/\varepsilon_{cr} \leq 3.5$, where $\varepsilon_{cr} = f_{ct}/E_c$ is the concrete crack strain calculated from the tensile strength f_{ct} and Young's modulus E_c of concrete.

Reference in Chapter 15

- Kajikawa, Y., and Maeda, Y. (1985) : Fatigue strength of flange plate with stud shear connector subjected to combined tension and shear, J. Structural Eng./Earthquake Eng., JSCE, No.362/I-4, pp. 285-295.
- Hiragi, H., Matsui, S., and Fukumoto, Y. (1989) : Derivation of strength of headed stud shear connectors - Static strength -, J. Structural Eng., JSCE, Vol.35A, pp. 1221-1232.
- Ohtani, Y., Kinoshita, J., and Tsuji, B. (1994) : Design shear strength of stud anchor under combined loads, J. Steel Constr. Eng., JSSC, Vol.2, pp. 699-706.
- Sakai, F., Yabe, J., Ohgaki, K., Hashimoto, Y., and Tomoda, T. (1995) : A study on three-dimensional characteristics of composite bridge with two plate girders, J. of Struct. Eng., JSCE, Vol.41A, pp.945-954.
- Japan Society of Civil Engineers (1996) : Standard Specification for Concrete Structures.
- Sakai, F., Yabe, J., Ohgaki, K., and Hashimoto, Y. (1997) : A study on positioning of cross beam in composite two-plate-girder bridges, Bridge and Foundation Engineering, No.3, pp.31-38.
- Taira, Y., Amano, R., and Ohtuka, K. (1997) : Fatigue characteristics of perforated-plate dowels, JCI, Vol.19, No.2, pp.1503-1508.
- Hosaka, T., Hiragi, H., Koeda, Y., Tachibana, Y., and Watanabe, H. (1998) : An experimental study on characteristics of shear connectors in composite continuous girders for railway bridges, J. of Struct. Eng., JSCE, Vol.44A, pp.1497-1504.

- Uenaka, K., Kitoh, H., Uehira, K. and Sonoda, K. (1998): Shear bond characteristics of the embossed steel plates with headed studs, JCI, Vol20, No.3.
- Tokumitsu, S., Yamazaki, T. and Idemitsu, T. (1998): Reinforcing method for shearing force at the joint of steel-concrete composite beam with pre-shearing stress, Journal of Materials, Concrete Structures and Pavements, JSCE, Vol. 592/V-39, pp.63-72.
- JH (1998) : Construction of Inabegawa Bridge (Superstructure), Test report of shear strength of studs, Nagoya construction bureau.
- Mizuguchi, K., Komastu, H., Onobe, R., Miyaji, T., and Matsuno, S. (1999): Experimental studies on the high strength stud used for precast prestressed-concrete slabs, Proc. of Annual Conf. of JSCE, VolA.54, pp.312-313.
- Hosaka, T., Mitsuki, K., Hiragi,H., Ushijima, Y., Tachibana, Y., and Watanabe, H. (2000) : An experimental study on shear characteristics of perfobond strip and it's rational strength equations, J. of Struct. Eng., JSCE, Vol.46A, pp.1593-1604.
- Railway Technical Research Institute(2000) :Design Standards for Railway Structures and Commentary, Steel and Composite Structures .
- Ishikawa, T., Takeda, N, Fukunaga, Y., Nakamura, K., and Tanaka, H. (2001): Characteristics of shear capacity and fatigue strength of the stud jointed with a coupler, J. of Struct. Eng., JSCE, Vol.47A, pp.1355-1362.
- Hiragi, H., Tsubotani, T., Tsuru, A., Maeda, Y., Ishizaki, S., and Ikeo, R. (2001): An experimental study on static punching strength characteristics of nonuniform diameter stud, JSCE Kansai Chapter Proc. of Annual Conference of Civil Engineers, pp.I-51-1-I-51-2.
- Kitagawa, K., Hiragi,H., Watanabe, H.,and Tachibana, Y. (2001): Punching shear characteristics of delayed-composite stud, Proc. of Annual Conf. of JSCE, B, Vol.56, pp.558-559.
- Igase,Y., Suzuki,N., Suzuki,T., and Yanaka,T. (2002): An experimental study on horizontal shear slip characteristics and fatigue strength of angle-connector, Proc. of Annual Conf. of JSCE, I, Vol.57, pp.725-726.
- Hosaka, T., Mitsuki, K., Hiragi,H., and Ushijima, Y. (2002) : A study on evaluation of the shear strength and design of perforated-plate dowels, J. of Struct. Eng., JSCE, Vol.48A, pp.1265-1272.
- Japan Society of Civil Engineers (2002) : Guidelines for Performance Verification of Hybrid Structures (tentative) .
- Japan Road Association (2002) :Specifications for Highway Bridges and Commentary, II Steel Highway Bridges Volume.
- Nagai, M., Okui, Y., and Iwasaki, E. (2002): Comparative study on crack width evaluation methods for continuous composite girders, Journal of Structure Mechanics and Earthquake Engineering, Vol.710, No. I-60, pp.427-437.
- Nagai, M., Okui, Y., and Iwasaki, E. (2004): Evaluation of crack width of concrete slab and stress of reinforcing bar in continuous composite girder bridges, Journal of Structure Mechanics and Earthquake Engineering, Vol.759, No.I-67, pp.283-292.
- Okada, J., and Yoda, T. (2005) : Analytical study on the shear strength of 25 mm diameter headed stud connectors, Proc. of the 60th Annual meeting of JSCE, I-441, pp.879-880.
- Okui, Y., Honda, T., Khan, Q. and Nagai, M. (2005): Effective width formula of concrete slabs for crack width evaluation in continuous composite bridges, Journal of Structure Mechanics and Earthquake Engineering, Vol.780, No.I-70, pp.155-164.
- Kurita, A., Ito, S., Okada, J., and Yoshimura, N. (2005) : Composite bridge design of small and medium spans - EC technical steel research report 2003 -, Bridge and Foundation Engineering, Vol.39 (2005-12), pp.41-48.
- Okada, J., Yoda, T., Lebet, J.-P. (2006): A study of the grouped arrangement of stud connectors on the shear strength behavior, Structural Eng./Earthquake Eng., JSCE, Vol.23, No.1, pp.75-89.
- Japan Society of Steel Construction (JSSC) (2006): A Draft Proposal of Limit Design Method for Composite Girder Bridges, JSSC Technical Report No.70.
- Basler, K. (1961): Strength of plate girder in share, J. struct. div., ASCE, Vol.37, No.ST7, pp.151-180.
- Hanswille, G. (1986): *Zur Rissbereitenbeschraenkung bei verbundtraegern*, Technisch-weissenschaftliche Mitteilungen, Institut for Konstruktiven Ingenieurbau Ruhr-Universtate Bochum, Mittelitung, Nr.86-1 .

- Johnson, R.P., Hanswille, G. and Tschemmerngg, F. (1998) : The Eurocode for composite bridges, ENV194-2, Proceedings of Second World Conference on Steel Construction (enclosed on CD-ROM), Spain .
- Leonhardt, F., Andrä, W., Andrä, H-P. and Harre, W. (1987) : Neues, vorteilhaftes Verbundmittel für Stahlverbund-Tragwerke mit hoher Dauerfestigkeit, Beton-und Stahlbetonbau, vol.12, pp.325-331 .
- Comite Euro-International du Beton (1993): *CEB-FIP Model Code 1990*, Thomas Telford .
- Hanswille, G. (1997) : *Cracking of concrete, Mechanical model of the design rules in EUROCODE4*, Conf. Report, Composite Construction in Steel and Concrete (Ed. by C.D.Bucker et al), ASCE, pp.420-433 .
- AASHTO (2005): LRFD Bridge Design Specifications, SI Unit .
- European Committee for Standardization (CEN)(2003): Eurocode 4, Design of composite steel and concrete structures, 1994-2 .
- Gupta, V.K. , Okui, Y., Nagai, M. (2006) : Development of web slenderness limits for composite I-girder accounting for initial bending moment, Structural Eng./Earthquake Eng., JSCE, Vol.62A, No. 4, pp.854-864.

Standard Specifications for Steel and Composite Structures – 2007
I. General provision, II. Structural Planning, III. Design

First edition 2007

Published by
Committee on Steel structure
Subcommittee of Standard Specifications for Steel and Composite Structures
Japan Society of Civil Engineers

Yotsuya 1-chome Shinjuku-ku Tokyo, 160-0004 Japan
Fax +81-3-5379-2769 E-mail pub@jsce.or.jp
<http://www.jsce.or.jp>

ISBN 978-4-8106-0565-5

