



SIEMENS



Totally Integrated Power

# Planning of Electric Power Distribution

Technical Principles

## Navigation tips

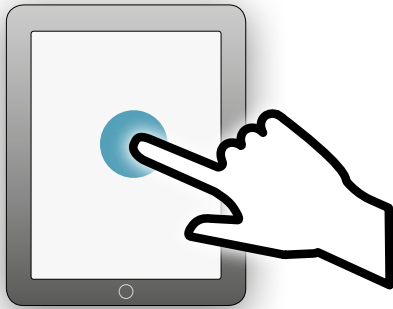

Touch screen to navigate

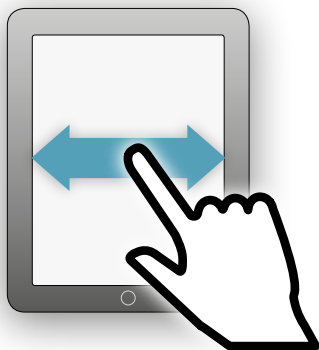

Scroll horizontally to switch between individual pages

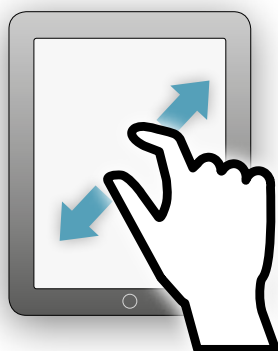

Pinch or stretch to zoom

Con-  
tents

Intro-  
duction

1

2

### Navigation bar

On every page you will find a navigation bar.

Click on the chapter title/number in the navigation bar to move to the start page of the relevant chapter.

Click on "Contents" at the top to view the contents page.

### Contents page

2.3 Estimation of a Concrete Value for the Power Demand from the Given Margins	21
2.4 Operating Voltages in Supply and Distribution Grids	25
2.5 Type of Power Supply	27
2.6 Central or Distributed Installation of Low-voltage Supply	29

On the contents page you will find a listing of the subchapters.

Click on a subchapter to navigate to the relevant text section.

### References to figures and tables

... standard EN 15232 can be used for the building management (see [Tab. 2/9](#)). However, note that energy efficiency class D from EN 15232 plays no role ...

A figure (Fig.) or table (Tab.) that is referred to for the first time in the text and does not appear on the same page will be indicated by a blue background (button).

Click on the reference to skip to the corresponding Fig./Tab.

**Tab. 1/1: Data centre (DaC) power demand dependent on the concept for redundancy and infrastructure**

[back to page 18](#)

You can navigate back from a figure or table to the page where it was first mentioned by clicking on the link with the blue background in the caption.



Totally Integrated Power

# Planning of Electric Power Distribution

Technical Principles



# Editorial

The planning of electric power distribution in buildings and infrastructure facilities is subject to constant transformation. The search for an assignment-compliant, dependable solution should fulfil those usual requirements placed on cost optimisation, efficiency, and time needs. At the same time, technical development innovations and findings from the practical world are constantly seeping into the planning process. Our books on electric power distribution are intended to support you in your work as a designer and to provide you with a continuously updated and dependable instrument.

Various volumes under the “application manual” term have been compiled over time. To introduce a form of structuring into the process, we will in future distinguish between planning and application manuals.

The specific requirements of infrastructure facilities of individual industries and building types on electric power distribution is worked on in the application manuals. Perhaps you have already made acquaintances with the two editions on high-rise buildings and data centres. This is the series we intend to continue with at intervals. We would be glad to take up any suggestions you may have here.

The planning manuals concern themselves more with those subjects generally used in planning electric power distribution. They are oriented to that fundamental know-how which is at the basis of all planning work. To this end, we are launching a new series which, initially, will consist of two volumes.

This newly designed first volume, “Planning of Electric Power Distribution – Technical Principles”, looks, in particular, at the general requirements and characteristics which are of interest in planning electric power distribution. The follow-up, “Planning of Electric Power Distribution – Products and Systems”, is being prepared. It will feature those technical details and descriptions of specific products and systems so as to fulfil the requirements specified in this volume.

To be in a position in future to handle appropriate, up-to-the-minute subjects, we would be particularly thankful to you – as our technically interested readers – for any information here. Please send us an e-mail to: [consultant-support.tip@siemens.com](mailto:consultant-support.tip@siemens.com) with reference to: TIP Planning Manuals.

Detlef Lucius

Vice President  
Consultant Support for Totally Integrated Power

# Contents

1  
2  
3  
4  
5  
6  
7  
8  
9  
10  
11  
12  
13  
14  
15  
16  
17

<b>Integrated Planning – Cost Reduction</b>	<b>6</b>	<b>6</b>	<b>Dimensioning of Power Distribution Systems</b>	<b>98</b>
<b>1 General Planning Considerations</b>	<b>10</b>	6.1	Circuit Types and Basic Rules	99
1.1 The Planner’s Tasks	10	6.2	Power System Protection and Safety Coordination	102
1.2 Contents of the Individual Project Phases	10	<b>7</b>	<b>Protection Devices for Low-Voltage Distribution</b>	<b>110</b>
1.3 Design/Performance Specification	12	7.1	Circuit-breakers with Protection Functions	112
1.4 Some Basic Considerations on Power Distribution	13	7.2	Fuses	116
1.5 Standards, Standardisation Bodies, and Guidelines	14	7.3	Switchgear Assemblies	117
<b>2 Basics for Drafting Electrical Power Distribution Systems</b>	<b>16</b>	7.4	Miniature Circuit-breaker	129
2.1 Requirements to Electrical Power Systems in Buildings	17	7.5	Selectivity in Low-Voltage Grids	134
2.2 Estimate of Power Demand	18	7.6	Protection of Low-Voltage Capacitors	147
2.3 Estimation of a Concrete Value for the Power Demand from the Given Margins	21	7.7	Protection of Distribution Transformers	148
2.4 Operating Voltages in Supply and Distribution Grids	25	<b>8</b>	<b>Medium-Voltage Switching Devices and Switchgear</b>	<b>164</b>
2.5 Type of Power Supply	27	8.1	Medium-Voltage Switchgear	165
2.6 Central or Distributed Installation of Low-voltage Supply	29	8.2	Medium-Voltage Switching Devices	175
2.7 Network Configurations	30	8.3	Medium-Voltage Protection	185
2.8 Power Supply Systems according to their Type of Connection to Earth	32	<b>9</b>	<b>Transformers</b>	<b>194</b>
<b>3 Power System Planning Modules</b>	<b>36</b>	9.1	Electrical Design	194
<b>4 Planning of Medium-Voltage Grids</b>	<b>44</b>	9.2	Losses and Profitability Estimates	197
4.1 Components for the Configuration of Medium-Voltage Grids	45	9.3	Construction of Oil-immersed Transformers	199
4.2 Medium-Voltage Power Supply Concepts	47	9.4	GEAFOL Cast-resin Dry-type Transformers	201
4.3 Configuration of the Switchgear	50	9.5	Power Converter Transformer	203
4.4 Power System Protection Equipment	51	9.6	FITformer® REG – Regulated Distribution Transformer	204
4.5 Connection of the Neutral Point in the Medium-Voltage Cable Network	60	9.7	Transformer Operation	206
<b>5 Quality of Supply</b>	<b>68</b>	9.8	Transformer Room	209
5.1 Voltage Quality	69	<b>10</b>	<b>Low-Voltage Switchgear and Distribution Systems</b>	<b>214</b>
5.2 Electromagnetic Compatibility	75	10.1	Parameters and Forms of Low-Voltage Switchgear	214
5.3 Availability and Redundancy	78	10.2	Planning Notes	220
5.4 Reactive Power and Compensation	84	10.3	Motor Control Centre	225
5.5 Protection Against Lightning Current and Overvoltage	92	10.4	Distribution Boards	225
		10.5	Busbar Trunking Systems	228

<b>11</b>	<b>Low-voltage Protection and Switching Devices</b>	<b>234</b>	<b>17</b>	<b>Appendix</b>	<b>346</b>
11.1	Circuits and Device Assignment	236	17.1	Characteristics of Grid Supply Types	346
11.2	Requirements on the Protection Devices in the Three Circuit Types	237	17.2	List of Standards	347
11.3	Residual Current and Arc-fault Detection Devices	240	17.3	List of Abbreviations	357
			17.4	Bibliography	361
			17.5	Conversion Factors and Tables	362
<b>12</b>	<b>Starting, Switching, and Protecting Motors</b>	<b>248</b>		<b>Imprint</b>	<b>366</b>
12.1	Protecting Electric Motors	248			
12.2	Switching Electric Motors	249			
12.3	Comparison of Connections for Motor Start-up	256			
12.4	Safety of Machines	258			
<b>13</b>	<b>Supply using Converters and Generators</b>	<b>262</b>			
13.1	UPS Systems	263			
13.2	Embedded Generation Systems	266			
<b>14</b>	<b>Energy Management</b>	<b>278</b>			
14.1	Measured Variables for Energy Transparency	279			
14.2	Graphic Representations in Energy Management	281			
14.3	Evaluation Profiles	284			
14.4	Characteristic Values	284			
14.5	Electricity Market Observations	286			
14.6	Operational Management	291			
14.7	Normative Basis for an Energy Management System	292			
<b>15</b>	<b>SIMARIS Planning Tools for the Efficient Planning of Power Distribution</b>	<b>296</b>			
15.1	Dimensioning with SIMARIS design	297			
15.2	Determining Space Requirements with SIMARIS project	298			
15.3	Displaying Characteristic Curves with SIMARIS curves	299			
15.4	Tool Efficiency	299			
<b>16</b>	<b>Lighting Inside Buildings</b>	<b>302</b>			
16.1	Basic Data Establishment	302			
16.2	Building Analysis	305			
16.3	Normative Specifications	305			
16.4	Lighting Scheme	312			
16.5	Lighting Calculation	318			
16.6	Emergency Lighting	329			

1

2

3

4

5

6

7

8

9

10

11

12

13

14

15

16

17



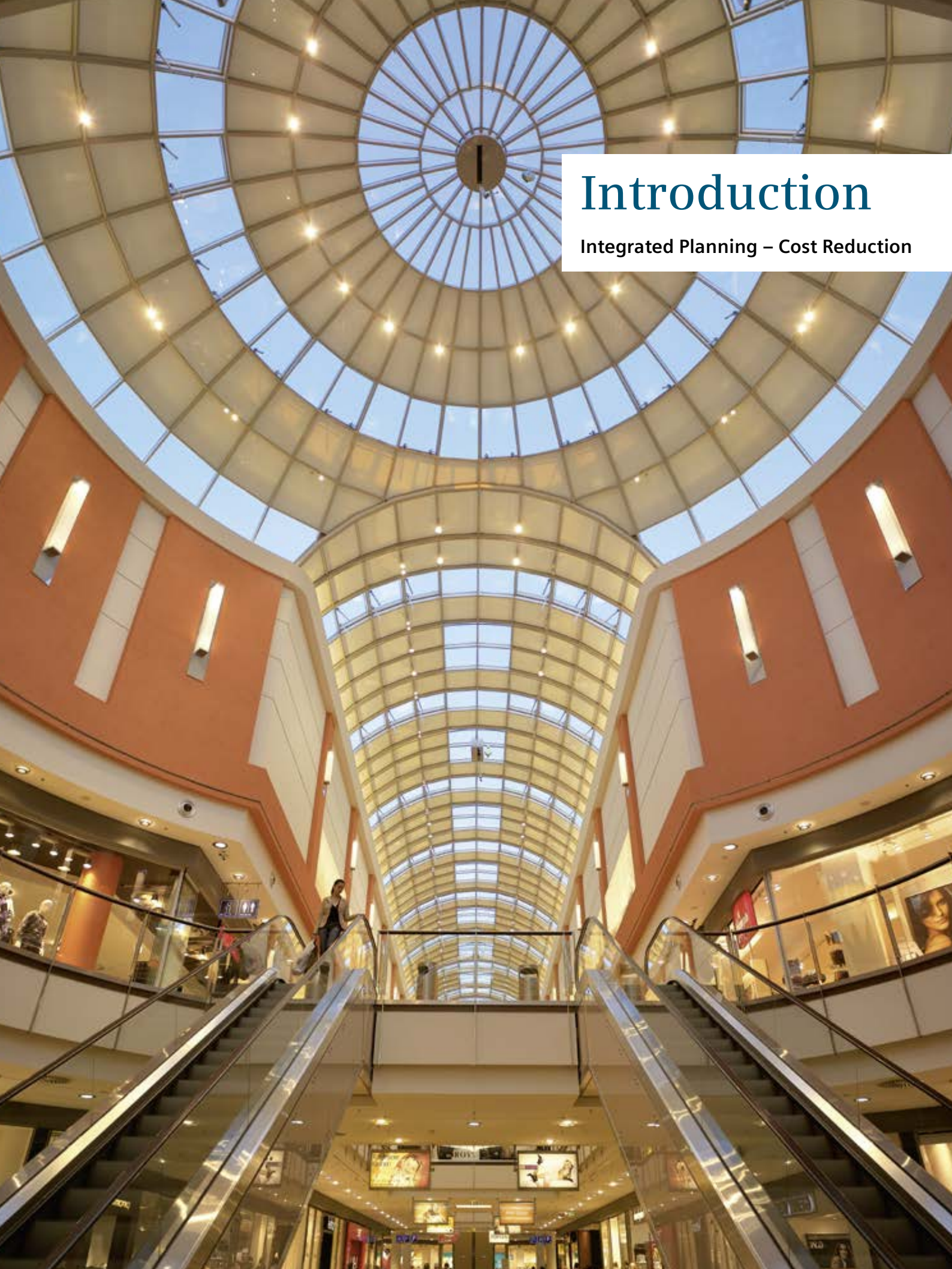

# Introduction

Integrated Planning – Cost Reduction

# Integrated Planning – Cost Reduction

1  
2  
3  
4  
5  
6  
7  
8  
9  
10  
11  
12  
13  
14  
15  
16  
17

Increasingly greater demands are placed on modern buildings. As early as in the planning stage, demands for a high level of safety, flexibility throughout the entire life cycle, a low level of environmental pollution, the integration of renewable energies and low costs must be taken into account in order to exploit the full potential of economic efficiencies and fulfilling technical demands. A special challenge is the coordination of the individual installations. Basically, the main installations are heating, ventilation, air conditioning and refrigeration, fire protection, protection against intrusion, building control system and electric power distribution. With innovative planning, the requirements are not simply broken down to the individual installations, but have to be coordinated.

In the German Fees Ordinance for Architects and Engineers (HOAI) [1], various concepts associated with buildings and developments are defined as follows:

1. "Properties" represent buildings, space-enclosing developments, outdoor facilities, engineering structures, transportation installations, load-bearing structures, and technical system equipment
2. "Buildings" represent self-contained, roofed, usable structures which people can enter and which are suitable or appointed for providing shelter for humans, animals or objects
3. "New structures and new installations" represent properties which are newly constructed or set up
4. "Rebuilt structures" represent previously dismantled properties which are set up anew on existing structures or installations; they are considered as new structures if new planning is required
5. "Extensions" represent additions to an existing property
6. "Conversions" represent transformations of an existing property involving modifications of the substance

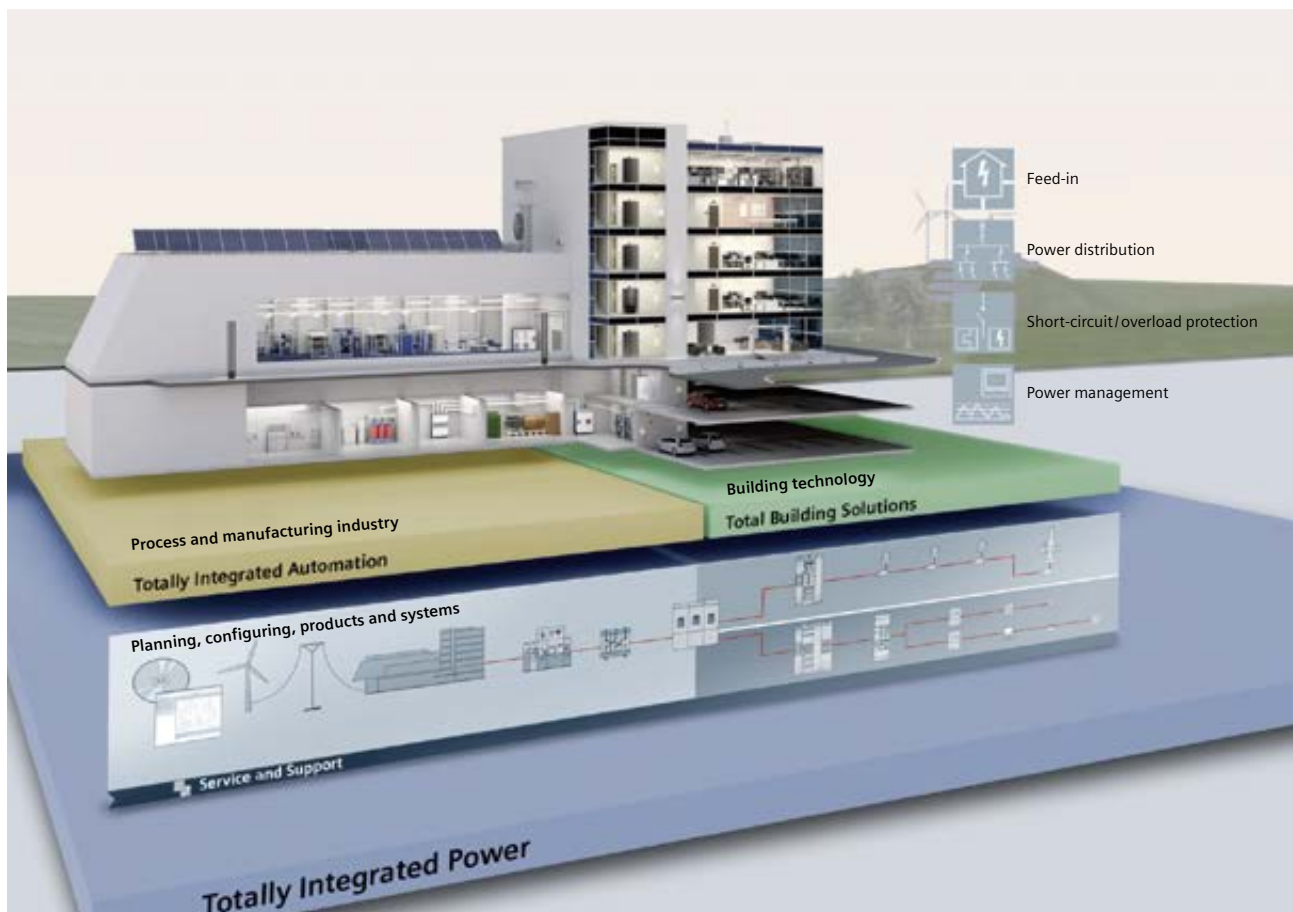

Totally Integrated Power – the long-term power distribution as foundations for Totally Integrated Automation and Totally Building Solutions

7. "Modernisations" represent structural steps taken to sustainably increase the practical value of a property - given they do not fall under Items 5, 6 or 9
8. "Space-enclosing developments" refer to the inner design or set-up of interiors without significant incursions made into the substance or structure; they can come to light in conjunction with work undertaken in Items 3 to 7
9. "Renovation" refers to steps for restoring the originally intend condition (designated condition) of a property given that they are not covered by Item 4 or by steps envisaged under Item 7
10. "Maintenance work" represents steps taken to retain the designated condition of a property
11. "Outdoor facilities" represent planned outdoor areas or spaces and appropriately designed facilities in association with or in structures

Regarding the planning concept for power supply, it is not only imperative to observe standards and regulations, it is also important to discuss and clarify economic and technical interrelations. To this end electric equipment, such as distribution boards and transformers, is selected and rated in such a way that an optimum result for the power system as whole is achieved rather than focusing individual components. All components must be sufficiently rated to withstand normal operating conditions as well as fault conditions. In addition, the following important aspects must be considered, when drawing up the power supply concept:

- Type, use, and shape of the building (e.g. high-rise building, low-rise building, multi-storey building)
- Load centres must be determined, as well as possible routes for supply lines and possible installation sites for transformers and main distribution boards
- Building-related connection values according to specific area loads that correspond to the building's type of use
- Statutory provisions and conditions imposed by building authorities
- Requirements by the distribution system operator (DSO)

The greatest potential for the optimisation of a project is during the planning phase. At this stage, the course is set for additional costs and cost increases which may incur during the erection and subsequent use of the building.

For the purpose of integrated planning, a building is regarded as an entity, functionality is defined in line with the processes running without limiting it to the individual installations as used to be done in traditional approaches. To this end it is necessary to define specifications comprehensively as early as in the planning stage. This is the only way to implement a solution with optimally matched systems and components. A seamless technical integration

of the different systems makes it possible to attain maximum process efficiency and reliability. At the same time, costs weighing on building investors, users, and operators can be reduced by exploiting synergies.

Integrated planning utilises the synergies of well matched, intelligent, integrated systems and products from a single supplier and implements them in cost-effective solutions. Interfacing and elaborate harmonization of different systems and products becomes obsolete. The expense for spare parts management and procurement is reduced. Integrated communication systems can be used to connect power supply/distribution systems and products to other installations such as automated process and production systems or automated building management systems. The wiring expense can be substantially reduced by a well matched concept and thus the wider utilisation of the cable infrastructure for data transmission attained from such a concept. These are merely some examples, how the cost-benefit ratio can be crucially improved by integrated planning as compared to conventional planning.

The focus of Totally Integrated Power (TIP) lies on all power distribution components as an integrated entity. TIP offers everything that can be expected from a future-oriented power distribution system: openness, integration, efficient planning tools, manifold options for communication and, as a result, a substantial improvement in efficiency. When regarding power distribution requirements in terms of the building automation, fire protection and safety systems installations, it becomes soon obvious that the better the individual installations are networked, the greater the rise in savings potential. Cost reductions up to 25% are feasible. Investors and building operators can thus provide a cost-effective power supply system and boost its efficiency.

As a rule, greater efficiency provides the investor with benefits – arising from approval and financing simplifications – in assessing the building project. This also enables investors and operators to provide a more cost-efficient and environmentally friendly energy supply system for which potential customers can be more easily won over and the required earnings obtained. Users benefit from high-level electricity supply in both quality and quantity at favourable conditions.

1

2

3

4

5

6

7

8

9

10

11

12

13

14

15

16

17



# Chapter 1

## General Planning Considerations

1.1 The Planner's Tasks	10
1.2 Contents of the Individual Project Phases	10
1.3 Design/Performance Specification	12
1.4 Some Basic Considerations on Power Distribution	13
1.5 Standards, Standardisation Bodies, and Guidelines	14

# 1 General Planning Considerations

On the one hand, it is up to the planner to win an edge over his competitors and gain unique selling points by offering modern, innovative concepts for the layout of power supply systems and the selection of equipment. But on the other hand, he is also responsible for his planning work, which means that he may be held liable for damages. Therefore it is important to clarify the project scope and the economic conditions with the owner / developer at an early stage.

## 1.1 The Planner's Tasks

The initial project planning stages are of vital importance in this context. They determine the basic set-up and guidelines for the further course of the project. Wrong assumptions and imprecise specifications may result in system oversizing which may bring about unnecessary costs. Undersizing may result in overload and plant failures. This manual about the technical principles of planning shall assist you in sizing the superordinate components for technical installations in buildings properly even in these initial project stages. Its focus is on components, systems and processes in electric power distribution.

## 1.2 Contents of the Individual Project Phases

According to the German Fees Ordinance for Architects and Engineers (HOAI), the services of planners are divided into nine service phases:

1. Establishment of basic data
2. Preliminary planning
3. Concept planning
4. Approval planning
5. Implementation planning
6. Preparation to the contract awarding procedure
7. Participation in the awarding procedure
8. Property surveillance (construction surveillance or management)
9. Property supervision and documentation

This manual focuses on the first three planning phases and the associated tasks of the planner involved.

### Phase 1 – Establishment of basic data

- Task definition
- Review of the project situation
- Site analysis
- Operations planning
- Preparation of a room concept
- Preparation of a concept on the functional scope
- Environmental impact assessment
- Recommendations for the total power demand
- Formulation of decision-making aids for the selection of other experts involved in the planning
- Summary of results

### Phase 2 – Preliminary planning (project and planning preparations)

- Analysis of the basis
- Coordination of objectives (boundary conditions, conflicting objectives)
- Preparation of a planning concept that also includes alternative solutions
- Integration of services rendered by other experts involved in the planning
- Drawing up of a functional scheme or block diagram for each plant
- Clarification and explanation of the fundamental interrelations, processes and conditions in the context of urban development and design, functions, technology, building physics, economics, energy management (for example regarding efficient power utilisation and the use of renewable energies) and landscape ecology, as well as the impact on and sensitivity of the affected ecosystems
- Preliminary negotiations with public authorities and other experts involved in the planning as to whether an official approval can be obtained
- Cost estimation (in Germany in compliance with DIN 276 or with statutory provisions for cost calculations of residential dwellings)
- Compilation of all preliminary planning results

**Phase 3 – Concept planning (system and integration planning)**

- Working through the planning concept which was created. Subject-specific requirements and the specialized planning departments – which are integrated through property planning – are now considered
- Determination of all systems and plant components
- Coordination of all wall/ ceiling penetrations and specification of loads required for planning the load-bearing structures (without drawing apertures or slits plans)
- Step by step preparation of a drawing solution up to the final draft
- Participation in negotiations with public authorities and other experts involved in the planning as to whether an official approval can be obtained
- Cost calculation (in Germany based on DIN 276) and cost controlling by comparing the calculation with the initially prepared cost estimate

Special services must be individually negotiated between the client and the planner. The following is detailed for the first three phases of planning technical equipment in the HOAI:

- Establishment of basic data:
  - System analysis under various aspects such as feasibility, expense, benefit, profitability and environmental compatibility
  - Data acquisition
  - Optimisation potential with regard to energy saving and environmental compatibility
- Preliminary planning:
  - Testing and model testing
  - Plant optimisation with regard to energy consumption and emission of pollutants
  - Preparation of optimised energy concepts
- Concept planning:
  - Preparation of data for the planning of third parties
  - Detailed profitability verification
  - Operating cost calculations
  - Detailed comparison of pollutant emissions
  - Drawing up the technical part of a room finishing schedule (“Raumbuch”)

Fig. 1/1 shows schematically which focal points of planning are covered by TIP.

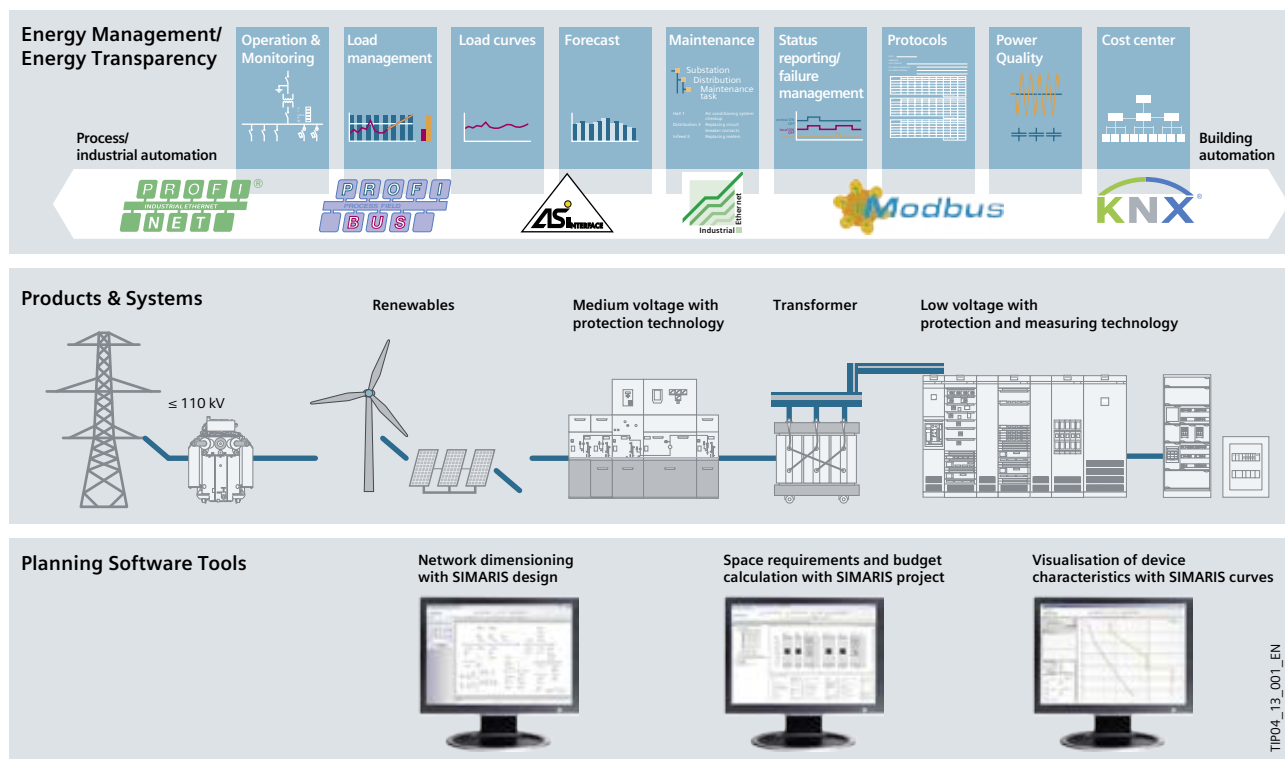

Fig. 1/1: Totally Integrated Power – integrated solutions for electrical power distribution

### 1.3 Design/Performance Specification

The design specification and the performance specification are important aids in the first phases.

#### Design specification

The design or product specification describes the “What?” and “For which purpose?” and outlines the basic requirements. It is a rough target setting of the contract for the contractor.

- It specifies the scope of requirements defined by the contract awarding party as regards the deliveries and services to be performed by the contractor within the scope of the contract
- It describes the direct requirements and the desires placed in a planned project or product from the user's point of view
- It serves as a basis for the invitation to tender, the tender or quotation, and the contract
- Requirements shall be quantifiable and verifiable
- The design specification is drawn up by the (external or in-house) awarding party, and it is addressed to the contractors
- In software development, the design specification constitutes the result of the planning phase and is usually worked out by the developers as a preliminary stage to the performance specification

#### Performance Specification

The performance or feature specification represents the target concept and is technically detailed so far that it can act as the basis for a technical specification.

- It is a detailed description of a service to be performed, for example, the erection of a technical plant, the construction of a tool, or the creation of a computer program

- It describes the solutions which the contractor has worked out for how to implement the project on the basis of the design specification defined by the customer
- The questions as to “How” a project should be put into practice and “Which tools or resources” are to be employed are dealt with in the performance specification
- The contents of the design specification are described in more detail, completed and written into a plausible implementation concept and combined with technical operating and maintenance requirements

Usually, each of the requirements of the design specification can be assigned to one or more services defined in the performance specification. This also illustrates the order of the two documents in the development process: A requirement is fulfilled, when the corresponding feature is implemented.

When a design or performance specification is drawn up, it must be considered that subordinate targets such as investment, losses, reliability, quality, and much more may mutually influence one another. Listing up such conflicting relations and weighing them in the project context will foster planning decisions and hence the focus that is placed on the design and performance specification.

Weighing in the context of design or performance specification must be based on different questions posed. Tab. 1/1 shows a simple correlation matrix in which the competing situation of individual sub-targets is assessed. For example, sub-target 2 – Low line losses – is strongly influenced by sub-target 1 – Cost of investment – whereas sub-target 4 – High reliability of supply – has no immediate interrelation with line losses.

Subgoals		1	2	3	4	5	6	7	8	9
1	Low investment costs	–	●	●	●	●	■	○	■	■
2	Low power losses	●	–	○	○	○	○	■	○	○
3	Process-compliant coverage of the power demand	●	○	–	○	○	○	●	○	○
4	High reliability of supply	●	○	○	–	○	○	●	○	○
5	High voltage quality	●	○	○	○	–	○	■	○	○
6	Low hazard for man and machine	■	○	○	○	○	–	○	○	○
7	Low maintenance and repair expense	○	■	●	●	■	○	–	■	○
8	Ease of operation	■	○	○	○	○	○	■	–	○
9	High environmental compatibility	■	○	○	○	○	○	○	○	–

● Strong competition ■ Competition ○ No or irrelevant competition

Tab. 1/1: Competitive situation during planning decisions [2]



## 1.4 Some Basic Considerations on Power Distribution

With regard to electric power supply, the most important task in the stage of establishing basic data is the estimation of the power required for supply. In order to attain a high level of efficiency, the components should work with a load of 70 to 80% of the maximum power output. Undersizing causes malfunctions, while oversizing results in excess costs.

### Network configuration and sources of supply

The network configuration is determined dependent on the requirements resulting from the building's use. In line with the specifications made by the installation company and the intended use of the building, the required power output must be distributed between different sources of supply. If redundancy is a system requirement, an additional reserve must be considered in the planning. Besides the demand to be met by the normal power supply (NPS), the power required from a safe and reliable source of supply must also be estimated. This demand of safety power supply (SPS) is divided between the emergency standby power system (ESPS) and the uninterruptible power supply (UPS). When the NPS fails, the UPS shall be supplied from the ESPS. In addition, the power demand of safety equipment (IEC 60364-7-710 or respectively DIN VDE 0100-710, IEC 60364-7-718 or respectively DIN VDE 0100-718) to be supplied by the SPS must be considered. The dimensioning of the individual components results from the estimate of energy and power required and their allocation to different sources of supply.

### Technical equipment rooms

Besides a proper component rating, another essential planning aspect is the specification of the size and location of the equipment rooms required for electric installations, which should take place at the beginning of the planning considerations. The dimensions of these technical equipment rooms depend on the dimensions of the components required and the relevant safety regulations. Boundary conditions such as room ventilation, pressure relief in the event of an arc fault, ceiling loads and access ways for moving items in must also be taken into consideration when drawing up room and building plans. Over-dimensioned rooms reduce the profitability of a building (room utilisation). Under-dimensioned rooms may prevent that a plant is erected in such a way that it can be approved, or at least force the use of expensive custom solutions for the technology applied. This planning manual contains aids for determining the room dimensions required for the individual components.

## 1.5 Standards, Standardisation Bodies, and Guidelines

When planning and erecting buildings, many standards, regulations, and guidelines must be observed and complied with in addition to the explicit specifications made by the building and plant operator (e.g. factory regulations) and the responsible distribution system operator (DSO). If internationally applicable standards and texts are used in the following sections, they will be listed in the Appendix together with the documents which are specifically used in Germany.

To minimise technical risks and/or to protect persons involved in handling electric equipment or components, major planning rules have been compiled in standards. Standards represent the state of the art, they are the basis for evaluation and court decisions. Technical standards are desired conditions stipulated by professional associations which are however made binding by legal standards such as health and safety at work laws. Furthermore, the compliance to technical standards is crucial for any operating licence granted by authorities, or insurance coverage. While in past decades, standards

were mainly drafted at a national level and debated in regional (i.e. European, American etc.) committees, it has now been agreed upon that drafts shall be submitted at the central (IEC) level and then be adopted as regional or national standards. Only if the IEC is not interested in dealing with the matter of if there are time constraints, a draft standard shall be prepared at the regional level. The interrelation of the different standardisation levels is illustrated in Tab. 1/2. A complete list of IEC members and links to more detailed information can be obtained at

[iec.ch/members\\_experts](http://iec.ch/members_experts)

Overview of standards and standardisation bodies					
Regional	Amerika PAS	Europa CENELEC	Australien	Asien	Afrika
National	USA: ANSI CA: SCC BR: COBEI ...	D: DIN VDE I: CEI F: UTE GB: BS ...	AUS: SA NZ: SNZ ...	CN: SAC IND: BIS J: JISC ...	SA: SABS
ANSI	American National Standards Institute				
BIS	Bureau of Indian Standards				
BS	British Standards				
CENELEC	European Committee for Electrotechnical Standardization (Comité Européen de Normalisation Electrotechnique)				
CEI	Comitato Ellettrotecnico Italiano				
COBEI	Comitê Brasileiro de Eletricidade, Eletrônica, Iluminação e Telecomunicações				
DIN VDE	Deutsche Industrie Norm Verband deutscher Elektrotechniker				
EN	European Norm				
IEC	International Electrotechnical Commission				
JISC	Japanese Industrial Standards Committee				
PAS	Pacific Area Standards				
SA	Standards Australia				
SABS	South African Bureau of Standards				
SAC	Standardisation Administration of China				
SCC	Standards Council of Canada				
SNZ	Standards New Zealand				
UTE	Union Technique de l'Electricité et de la Communication				

Tab. 1/2: Outline of national and regional standards in electrical engineering



# Chapter 2

## Basics for Drafting Electrical Power Distribution Systems

2.1 Requirements to Electrical Power Systems in Buildings	17
2.2 Estimate of Power Demand	18
2.3 Estimation of a Concrete Value for the Power Demand from the Given Margins	21
2.4 Operating Voltages in Supply and Distribution Grids	25
2.5 Type of Power Supply	27
2.6 Central or Distributed Installation of Low-voltage Supply	29
2.7 Network Configurations	30
2.8 Power Supply Systems according to their Type of Connection to Earth	32

# 2 Basics for Drafting Electrical Power Distribution Systems

Electrical power distribution requires integrated solutions. Totally Integrated Power (TIP) provides support for working out suitable solutions. This comprises software tools and support for planning and configuring as well as a perfectly harmonized, complete portfolio of products and systems for integrated power distribution, ranging from the medium-voltage switchgear to the final circuit. With TIP Siemens renders support to meet requirements such as:

- Simplification of operational management by a transparent, simple network topology
- Low power losses, for example by medium-voltage-side power transmission to the load centres
- High reliability of supply and operational safety of the installations, even in the event of individual equipment failures (redundant supply, selectivity of the power system protection, and high availability)
- Easy adaptation to changing load and operational conditions
- Low operating costs thanks to maintenance-friendly equipment
- Sufficient transmission capacity of the equipment under normal operating conditions as well as in fault conditions to be handled
- Good quality of the power supply, meaning few voltage changes due to load fluctuations with sufficient voltage symmetry and few harmonic distortions in the voltage
- Observance of valid IEC/EN/VDE regulations as well as project-related regulations for special installations

Qualified planning of a power supply concept which considers the above-mentioned aspects is the key to the efficiency of electric power supply. Power supply concepts must always be assessed in the context of their framework parameters and project goals.

Siemens TIP supports engineering consultants in power system design and configuration (see Fig. 2/1) with a wide range of services. Our TIP contact persons (please find their contact data on the Internet at [siemens.com/tip-cs/contact](http://siemens.com/tip-cs/contact)) also make use of their personal contact to you to present you planning tools such as SIMARIS design, SIMARIS project and SIMARIS curves.

Besides planning manuals, Siemens also offers application manuals, which describe the planning specification of certain property types like high-rise buildings, hospitals or data centres, and more network calculation tools like SINCAL, or configuration tools such as Profix for medium-voltage switchgear.

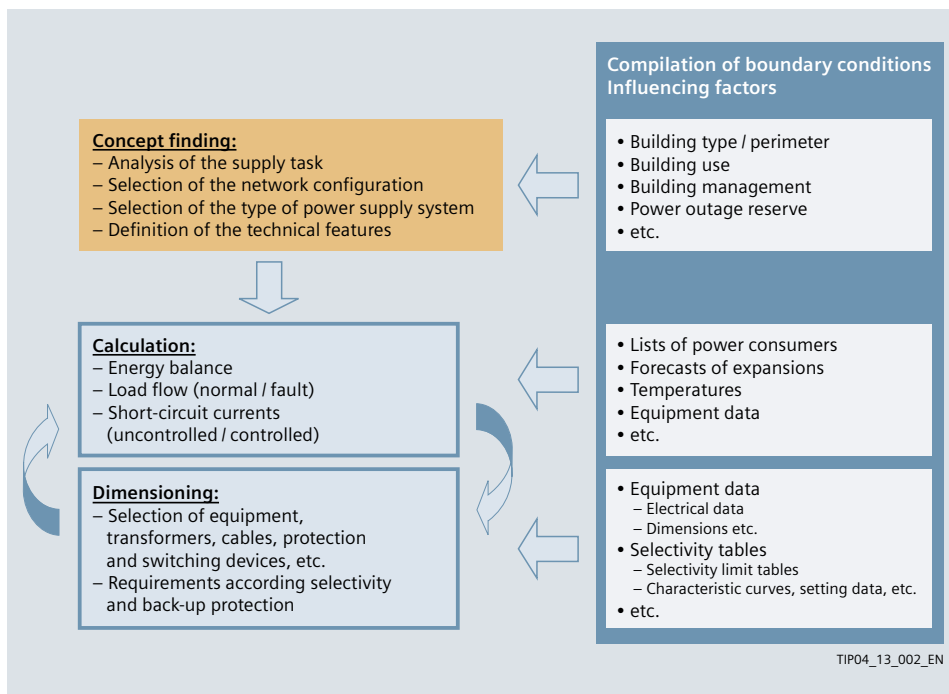

Fig. 2/1: Tasks of network planning and configuration

## 2.1 Requirements to Electrical Power Systems in Buildings

When electric networks are planned, largely ambivalent requirements of the three project life stages must be considered:

Investment – Installation – Operation

Tab. 2/1 renders a assessment of the expense incurring in these different “life stages”.

### Further influencing factors

The essential properties of a network are determined by the following requirements:

- Usage /consumers or respectively purpose of power distribution, this means energy report, power density, and load centres (see Tab. 2/2)
- Architecture, for example low-rise or high-rise building
- Operational and environmental conditions
- Official regulations /statutory provisions such as health and safety at work laws, building authorities
- By the supplying electrical utility company
  - Technical specifications with regard to voltage, short-circuit power, approval of maximum connected load, permissible technology
  - Use of power management, in order to profitably operate the power system within the given tariff options

	Investment	Installation	Operation
Costs of implementation	Minimum	Maximum	Irrelevant
Implementation time	Minimum	Minimum	Irrelevant
Technology	Cost-effective	Easy installation	Flexible operation
Space requirements for technical installations	Minimum	Maximum	Irrelevant
Period of use	Maximum	Irrelevant	Maximum
Fire load	Irrelevant	Irrelevant	Minimum
Operating costs (e.g. insurance premiums)	Irrelevant	Irrelevant	Minimum

Tab. 2/1: Relation between expense and life stages of a project

Type of use	Features	Requirements	Consequences
Residential areas	Many small consumers	Low nominal currents at comparably high system short-circuit power	Back-up protection
	Ordinary persons not skilled or instructed in electrical installation matters	Protection against direct and indirect contact:	Mandatory RCCB
Offices	Many workplaces equipped with PCs	Voltage stability and reliability of supply	
	High proportion of capacitive loads	Countermeasures in case of harmonics	Choked compensation
	General escape routes	Safety power supply	Generator feed-in
Server rooms	Communication facilities (network)	Good electromagnetic compatibility (EMC)	TN-S system to minimise stray currents
		High reliability of supply	Redundancy, selective grading
		Safety power supply and uninterruptable operation	High-performance safety power supply, efficient UPS
Medical locations	Life-preserving machinery	High reliability of supply	Redundancy, selective grading, high-performance safety power supply
	Intensive care, ECG	Good electromagnetic compatibility (EMC)	TN-S system to minimise stray currents
		Containment of fault currents	IT system
Industrial locations	Mainly motor loads	High power demand per area	Busbar trunking systems

Tab. 2/2: Examples for various areas of use and their impact on electric grids and equipment

## 2.2 Estimate of Power Demand

The basis for planning and sizing power distribution is knowing the equipment to be connected and the resulting total power demand. Besides the power demand of large

machinery (motors, pumps, etc.), the demand of individual functional areas (office, parking, shop, ...) must be ascertained (Tab. 2/3 and Tab. 2/4).

Building use	Average power demand <sup>1)</sup>	Simultaneity factor <sup>2)</sup> g	Average building cost per walled-in area	Average cost for heavy-current installation in a walled-in area <sup>2)</sup>
	in W/m <sup>2</sup>		in €/m <sup>3</sup>	in €/m <sup>3</sup>
Bank	40–70	0.6	300–500	25–50
Library	20–40	0.6	300–450	20–40
Office	30–50	0.6	250–400	17–40
Shopping centre	30–60	0.6	150–300	12–35
Hotel	30–60	0.6	200–450	10–35
Department store	30–60	0.8	200–350	20–45
Small hospital (40-120 beds)	50–250	0.6	300–600	18–50
Hospital (200-1,000 beds)	20–120	0.6	200–500	10–40
Warehouse (no cooling)	2–20	0.6	50–120	3–18
Cold store	500–1,500	0.6	150–200	10–20
Apartment complex (without night storage/continuous-flow water heater)	10–30	0.4	180–350	18–35
Single-family house (without night storage/continuous-flow water heater)	10–30	0.4		
Museum	60–80	0.6	300–450	20–40
Parking garage	3–10	0.6	100–200	7–15
Production plant	30–80	0.6	100–200	10–40
Data centre <sup>3)</sup>	125–2,000 <sup>3)</sup>	0.4–0.9 <sup>3)</sup>	360–4,500 <sup>3)</sup>	60–2,200 <sup>3)</sup>
School	10–30	0.6	200–400	15–30
Gym hall	15–30	0.6	150–300	8–25
Stadium (40,000 – 80,000 seats)	70–140 <sup>**)</sup>	0.6	3,000–5,000 <sup>**)</sup>	30–70 <sup>**)</sup>
Old people's home	15–30	0.6	200–400	10–25
Greenhouse (artificial lighting)	250–500	0.6	50–100	5–20
Laboratory/Research	100–200	0.6		
Mechanical engineering industry	100–200	0.4		
Rubber industry	300–500	0.6		
Chemical industry <sup>***)</sup>		0.6		
Food, beverages and tobacco industry	600–1,000	0.8		

<sup>1)</sup> The values specified here are guidelines for demand estimation and cannot substitute precise power demand analysis.  
<sup>2)</sup> The simultaneity factor is a guideline for preliminary planning and must be adapted for individual projects.  
<sup>3)</sup> For data centres, Tab. 2/5 and its associated explanations show the boundary conditions and simple calculations for the given estimated values and their wide margins.  
<sup>\*)</sup> Per bed approx. 800–4,000 W; <sup>\*\*)</sup> Per seat; <sup>\*\*\*)</sup> Power demand strongly process-dependent

Tab. 2/3: Average power demand of buildings according to their type of use

Functional area/ building area	Average power demand <sup>1)</sup> in W/m <sup>2</sup>	Simultaneity factor <sup>2)</sup> g		Functional area/ building area	Simultaneity factor <sup>2)</sup> g
Hallway/anteroom, lobby	5–15	0.3		Building installations	
Staircase	5–15	0.3		Escalator	0.5
Equipment, general	5–15	0.3		Lift	0.3
Foyer	10–30	1		Sanitary systems	0.5
Access ways (e.g. tunnel)	10–20	1		Sprinklers	0.1
Recreation room/kitchenette	20–50	0.3		Heating	0.8
Toilet areas	5–15	1		Air conditioning	0.8
Travel centre	60–80	0.8		Cooling water system	0.7
Office areas	20–40	0.8		Refrigeration	0.7
Press/bookshop	80–120	0.8			
Flower shop	80–120	0.8			
Bakery/butcher	250–350	0.8			
Fruit/vegetables	80–120	0.8			
Bistro/ice cream parlour	150–250	0.8			
Snack bar	180–220	0.8			
Diner/restaurant	180–400	0.8			
Tobacco shop	80–120	0.8			
Hairdresser	220–280	0.8			
Dry-cleaner's/laundry	700–950	0.7			
Storage area	5–15	0.3			
Kitchens	200–400	0.7			
				Functional area/ building area	Average power demand <sup>1)</sup> in W/m <sup>2</sup>
				Electric floor heating, living area	65–100
				Electric floor heating, bathroom	130–150
				Night storage heating: low- energy house	60–70
				Night storage heating: house with "standard" insulation	100–110
				Small aircon unit	60
				Photovoltaics <sup>3)</sup> (max. output of the modules)	100–130

<sup>1)</sup> The values specified here are guidelines for demand estimation and cannot substitute precise power demand analysis.  
<sup>2)</sup> The simultaneity factor is a guideline for preliminary planning and must be adapted for individual projects. When dimensioning consumers in the safety power supply system (SPS), their simultaneity factor must be considered separately (empirical value:  $g \geq 0.8$  for SPS busbar).  
<sup>3)</sup> Average usable sun radiation in Germany per day 2.75 kWh/m<sup>2</sup>

Tab. 2/4: Average power demand of various functional/building areas [back to page 18](#)

### 2.2.1 Special Consideration of the Cost Situation for a Data Centre

For a data centre, there are a number of factors influencing, among other things, the specific power demand. Important aspects which result in a wide bandwidth of the estimations of power demand, simultaneity factor and specific costs are as follows:

- Differentiation between a self-contained building (data centre) or the ICT areas in a building
- Different technologies for air conditioning and power supply influence space requirements and energy efficiency

- Requirements as to availability determine redundancy and safety systems

The following assumptions are to be made for data centre-specific cost estimates:

- An area-specific power demand of 125 to 1,500 W/m<sup>2</sup> is assumed for a self-contained data centre (DaC in Tab. 2/5). The low value suggests a large space required for information technology and infrastructure (for example owing to high redundancies), whereas the high value suggests a high packing density of servers in the racks and modern cooling and power supply systems

- An area-specific power demand of 500 to 2,000 W/m<sup>2</sup> for rooms containing information technology in infrastructure buildings (IT room in Tab. 2/5). These values slightly differ from the ones mentioned above, since infrastructure components can be shared in the building
- The "Tier" structure (with ascending requirements I to IV) of the Uptime Institute, as described in [3], is used as a basis in connection with availability and the redundancy conditions upon which availability is founded. (n+1) redundancy of Tier IV results in approximately 2.5-fold costs for infrastructure components compared to Tier I without redundancy. The influence of the redundancy requirements placed on the specific space required is already taken into account in the first two items outlined here
- For the list of costs shown in the second part of Tab. 2/5, the installation components are summed up according to the cost group 440 – Power Installations listed in DIN 276-1. The following is considered:

- 441 – High and Medium-voltage Systems (Switchgear, Transformers)
- 442 – Embedded Power Generating Systems
- 443 – Low-voltage Switchgear
- 444 – Low-voltage Installation Systems
- 445 – Lighting Systems
- 446 – Lightning Protection and Earthing Systems

The data centre simultaneity factor in Tab. 2/3 has a leeway between 0.4 and 0.9 depending on the infrastructural environment and the redundancy capacities. In case of a (2n+1) redundancy (see chapter 5), the simultaneity factor to be chosen will be between 0.4 (for n = 2) and 0.5 (for a very large number n). Whereas without redundancy a very high simultaneity factor is possible in the data centre.

Average building cost of walled-in area in €/m <sup>3</sup>					
Average power demand in W/m <sup>2</sup>		Tier I	Tier II	Tier III	Tier IV
DaC	125	360	390	490	550
	1,500	1,625	2,000	3,000	3,800
IT room	500	690	810	1,130	1,400
	2,000	1,900	2,350	3,550	4,500
Average cost for Installation 440 – Heavy-current installation in a walled-in area* in €/m <sup>3</sup>					
Average power demand in W/m <sup>2</sup>		Tier I	Tier II	Tier III	Tier IV
DaC	125	60	75	130	160
	1,500	740	940	1,500	1,900
IT room	500	240	300	470	620
	2,000	900	1,100	1,750	2,300

\* The cost share of embedded electricity generating sets (generators and UPS systems) is approx. 70% and the cost share for high and medium-voltage switchgear, low-voltage switchgear, low-voltage installation systems, lighting systems and lightning protection, and earthing systems amounts to approx. 30% altogether.

Tab. 2/5: Data centre (DaC) power demand [back to page 18](#) dependent on the concept for redundancy and infrastructure

Class	D (C)	C (B)	B (A)	A (A+)
Offices	1.10	1	0.93	0.87
Auditoriums	1.06	1	0.94	0.89
Educational facilities (schools)	1.07	1	0.93	0.86
Hospitals	1.05	1	0.98	0.96
Hotels	1.07	1	0.95	0.90
Restaurants	1.04	1	0.96	0.92
Buildings for wholesale and retail	1.08	1	0.95	0.91

Tab. 2/6: Efficiency factors (electric) for the [back to page 21](#) building automation according to EN 15232 for different non-residential buildings



## 2.3 Estimation of a Concrete Value for the Power Demand from the Given Margins

The values for the average power demand in Tab. 2/3 and Tab. 2/4 cover a vast bandwidth of different prerequisites. When estimating the total power demand for the project to be planned, the individual margins of building types, functional areas and rooms must be substantiated. For this purpose, we provide an estimation procedure with various calibration factors below as a simple help. A similar procedure is also used in EN 15232. Efficiency factors are used in this procedure that quantify the classification of the technical building characteristics and the use of systems for building automation (BA) and technical building management (TBM).

These factors (Tab. 2/6) are calibrated later for our estimation procedure on a value range between 0 and 1 and utilised for a characterisation of BA/TBM and the technical building characteristics.

For our simple calculation model we confine to six features which are evaluated as equivalent:

- Building placement
- Room structure
- Level of comfort
- Air conditioning option
- Technical characteristics
- BA/TBM

Of course you can also use your own factors as additional boundary conditions. In any case, the planner and his client should coordinate procedures, so that the calculation is verifiable. Six calibration factors corresponding to the six characterisation features identify the power demand of the building in the model.

- Calibration factor  $k_{plc}$  for the building placement
- Calibration factor  $k_{struct}$  for the room structure
- Calibration factor  $k_{comf}$  for the level of comfort
- Calibration factor  $k_{clim}$  for the air conditioning options
- Calibration factor  $k_{tech}$  for the technical characteristics
- Calibration factor  $k_{BA/TBM}$  for the BA/TBM

As we do not want to apply any further weighting to the factors, the mean value of the calibration factors can be defined as the total value:

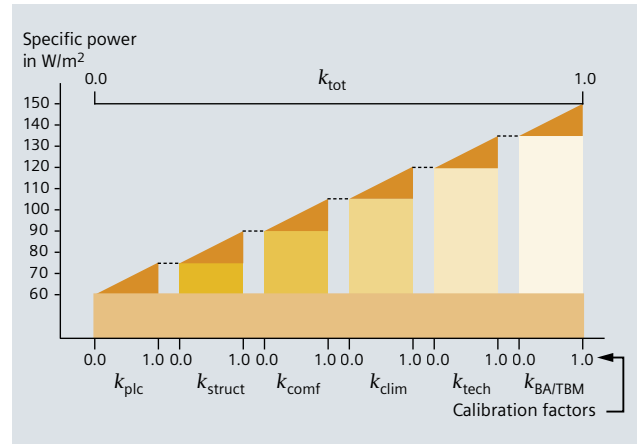

Fig. 2/2: Influence of the calibration factors on the specific power

$$k_{tot} = \frac{(k_{plc} + k_{struct} + k_{comf} + k_{clim} + k_{tech} + k_{BA/TBM})}{6}$$

To establish the specific power demand, we start from the lowest expected value  $p_{min}$  and determine a factor  $k_{tot}$  from our evaluations of the six sub-factors. This factor is used to weigh the difference between the minimum  $p_{min}$  and the maximum  $p_{max}$  and added to the minimum. The total factor  $k_{tot}$  then results from the mean of the individual factors (Fig. 2/2) in the above equation.

### Placement of the building – calibration factor $k_{plc}$

The location of the building has a fundamental influence on the planning of the power supply. The following questions can also be used to obtain an estimation:

- Do special conditions with regard to adjacent buildings have to be considered?
- Which traffic routes and connections can be used?
- Which type of power supply is possible and to which extent?
- Are there legal boundary conditions that have to be taken into consideration?

Note: Without any local particularities, the placement factor can be set to  $k_{plc} = 0.5$ .

**Room structure – calibration factor  $k_{struct}$**

Smaller rooms are easier to ventilate and light is distributed better in the room through reflection on the walls and ceiling. This calibration factor can also take the intended room height into account. Our estimations that are displayed in Fig. 2/3 as a curve also take into account that small rooms and areas frequently have direct ventilation and not air conditioning.

Larger rooms and halls generally have a larger calibration factor  $k_{struct}$ . At this point, we would again like to emphasise that the experience and project knowledge of the planner and the agreement with the client are decisive when determining the factors. Our Siemens TIP contact persons with their background knowledge support electrical designers in specific projects.

**Level of comfort and safety equipment – calibration factor  $k_{comf}$**

It is difficult to make general statements about comfort, as it is largely dependent on how the building is used. Whereas good lighting, an audio system and a monitoring system are considered as standard in a shopping centre, these characteristics may be considered as comfort features in office areas. On the other hand, blinds play no role in shop windows, but are important in hotels and offices. High-speed lifts for large loads require more power, as well as special stagecraft technology and technically sophisticated, medical diagnostic equipment. Control and monitoring systems make buildings safe and are the basis for a better user-friendliness. In the production sector, this factor will often play a subordinate part. If one factor is neglected,

the number of factors must be reduced accordingly in the above equation. To obtain a simple estimate, it is not worthwhile weighting the individual factors in the formula.

**Air conditioning – calibration factor  $k_{clim}$**

With regard to the air conditioning of a building, natural ventilation, the efficiency of the cooling equipment and the possibilities of reducing the solar radiation without impairing the light conditions in the rooms must be taken into account. In Germany, the Association of German Engineers (VDI) have considered the building-specific power demands of the air ventilation and cooling in guideline VDI 3807-4. The data described therein for the specific installed load of offices, hotel rooms, kitchens, data centres, theatres, department stores, parking garages etc. for different demand classes ranging from “very high” to “very low” has been converted into a curve for calibration factors (Fig. 2/4). The superimposition of lots of individual curves has shown that only types of use with a high demand for cooling, such as computer centres and kitchens, display a slightly different curve shape.

Computer rooms, which are better planned without windows, generally require more expensive air conditioning – constant temperature and humidity – although there is little effect from solar radiation. It should also be noted that the air conditioning depends on the room structure and the comfort requirements.

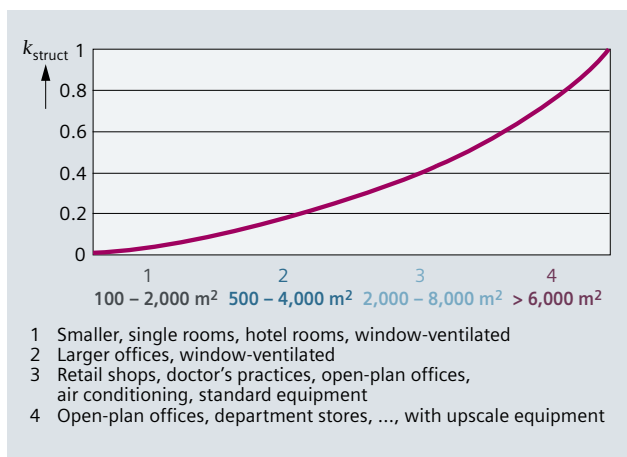

Fig. 2/3: Schematic dependency of the power demand from the building structure demonstrated through a standardised factor  $k_{struct}$

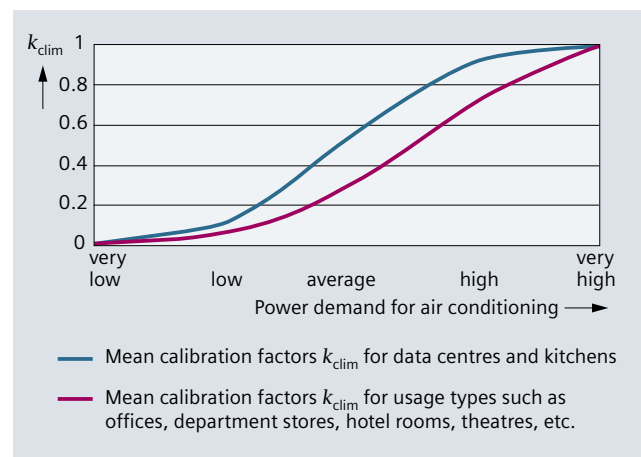

Fig. 2/4: Schematic dependency of the power demand from the building's air conditioning demonstrated through a standardised factor  $k_{clim}$

### Technical characteristics – calibration factor $k_{tech}$

Even when the functionality of the technical building equipment has been defined, the difference in the technical constructions is significant. High-speed lifts require higher starting currents than slower lifts, fans with EC motors (electronically controlled) save power and modern light fittings reduce the power demand, and the efficiency of many electrical consumers differ greatly from version to version.

A general classification for the energy efficiency according to the EN 15232 standard is listed in Tab. 2/7. The efficiency factors of EN 15232 are transformed in Tab. 2/8 to the desired calibration area between 0 and 1.

A distinction is not made for other types (such as sports facilities, warehouses, industrial facilities, etc.) so that the factor of 0.5 is selected for all classes.

Class	Energy efficiency
A	Highly energy-efficient devices and systems (low-friction AC drives, EC fans, LEDs, transistor converters, etc.)
	Regular maintenance, possibly with remote monitoring
	Extensive communication and control options
B	Improved efficiency devices and systems
	Extensive communication and control options
C	Standard devices and systems that represent the current state of technology during operation
	No communication options, only mechanical adjustment possible
D	Simple devices and systems that only satisfy the required functionality
	Only On/Off switch

Tab. 2/7: Classification of the technical characteristics of a building with regard to energy efficiency according to EN 15232

### Building management – calibration factor $k_{BA/TBM}$

In the same way as for the technical characteristics, standard EN 15232 can be used for the building management (see Tab. 2/9). However, note that energy efficiency class D from EN 15232 plays no role for the planning of BA/TBM systems in new buildings. The advantage of our procedure with scaled calibration factors is revealed here. Characterisation features can be adapted to the latest technology through the scaling and the classification always defined through one's own current experience.

We will therefore omit class D and select a new class A+, which in addition to the properties of class A, is characterised by remote monitoring, remote diagnostics, and remote control as well as analysis tools for BA/TBM, as part of the smart grid. For the four new classes C, B, A, and A+ we then adopt the old calibration factors from Tab. 2/8 accordingly (Class C → column D, Class B → column C, Class A → column B, Class A+ → column A of Tab. 2/8).

Efficiency class	D	C	B	A
Offices	1.0	0.57	0.26	0
Auditoriums	1.0	0.65	0.29	0
Educational facilities (schools)	1.0	0.67	0.33	0
Hospitals	1.0	0.44	0.22	0
Hotels	1.0	0.59	0.29	0
Restaurants	1.0	0.67	0.33	0
Buildings for wholesale and retail	1.0	0.53	0.24	0

Tab. 2/8: Calibration factors  $k_{tech}$  for the technical equipment of a building in accordance with EN 15232 for various non-residential buildings

**Estimated power demand**

The established calibration factor  $k_{tot}$  and the two limit values  $p_{min}$  and  $p_{max}$  allow to determine the specific power demand  $p_{spec}$  for the entire usable area of a building.

$$p_{spec} = p_{min} + (p_{max} - p_{min}) \cdot k_{tot}$$

To obtain the estimated power demand of the building, the specific power demand is multiplied by the usable area of the building.

Class	Energy efficiency and building management
A	Corresponds to highly energy-efficient BA systems and TGM <ul style="list-style-type: none"> <li>• Networked room control with automatic demand acquisition</li> <li>• Regular maintenance</li> <li>• Energy monitoring</li> <li>• Sustainable energy optimisation</li> </ul>
B	Corresponds to further developed BA systems and some special TBM functions <ul style="list-style-type: none"> <li>• Networked room control without automatic demand acquisition</li> <li>• Energy monitoring</li> </ul>
C	Corresponds to standard BA systems <ul style="list-style-type: none"> <li>• Networked building automation of the primary systems</li> <li>• No electronic room control, thermostatic valves on radiators</li> <li>• No energy monitoring</li> </ul>
D	Corresponds to BA systems that are not energy efficient. Buildings with such systems have to be modernized. New buildings must not be built with such systems <ul style="list-style-type: none"> <li>• No networked building automation functions</li> <li>• No electronic room control</li> <li>• No energy monitoring</li> </ul>

**Tab. 2/9: Efficiency classification for executing [back to page 23](#) the function of building automation and technical building management systems according to EN 15232**

## 2.4 Operating Voltages in Supply and Distribution Grids

Different voltages are used to fulfil the different tasks of electric power supply and distribution. According to international rules, there are initially two voltage groups:

- Low voltage (LV):  
up to and including 1,000 V AC (or 1,500 V DC)
- High voltage (HV):  
above 1 kV AC (or 1.5 kV DC)

Most electrical appliances used in household, commercial and industrial applications work with low voltage. High voltage is used not only to transmit electrical energy over very large distances, but also, finely branched, for regional distribution to the load centres. Different voltage levels are common for transmission and regional distribution because the tasks and requirements for switching devices and switchgear are very different. This is how the term 'medium voltage' emerged for voltages that are used to regionally distribute electrical energy (Fig. 2/5).

- Medium voltage (MV):  
above 1 kV AC up to and including 52 kV AC; most grid operating voltages are within the range of 3 to 40.5 kV (Fig. 2/5).

Power station sites are oriented towards the availability of primary energy sources, cooling systems, and other ambient conditions, therefore they are often removed from load centres. Electric transmission and distribution grids connect power stations with electricity consumers. The grids thus form a supra-regional backbone with reserves to ensure reliability of supply and for balancing load differences. High operating voltages (and therefore low currents) are preferred for power transmission in order to minimise losses. The voltage is then transformed to the usual values of the low-voltage grid in the load centres close to the consumer.

The boundary conditions for selecting the supply voltage and the design of the technical connection points are described in the Technical supply conditions of the distribution system operator (DSO). Depending on the situation of the DSO with regard to supply density, grid short-circuit power and supply quality, an installed capacity between 150 and 1,000 kW may make the connection to the medium-voltage level seem reasonable. Since there is no uniform set of rules, this must be discussed with the responsible DSO during planning.

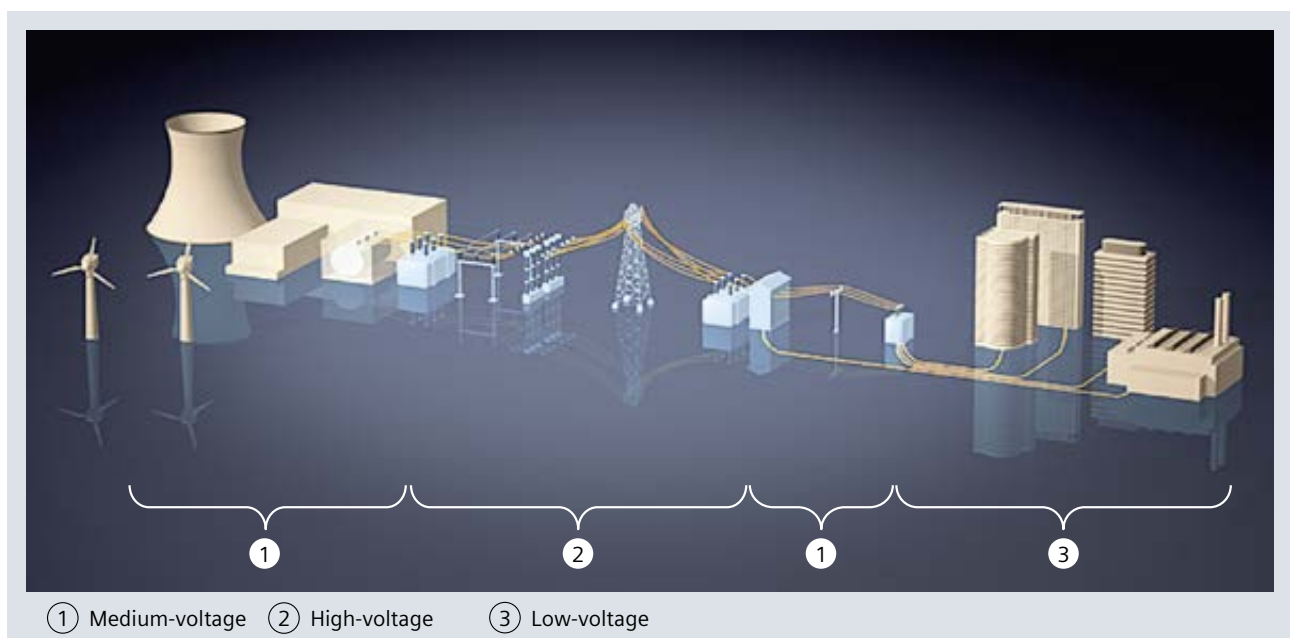

Fig. 2/5: Voltage levels between the power station and the consumer

Dependent on the DSO, a direct connection of the customer to a transformer substation of the DSO (grid level 6 in Tab. 2/10) may be possible in case of a power demand of more than 150 kW (house connection with 250 A), and if a connection to the grid above 300 or 400 kW needs to be created, a connection to the medium-voltage level (grid level 5) may be permitted. Often, a power factor  $\cos \varphi$  is also specified (Tab. 2/10).

In the local low-voltage grid, we additionally distinguish between grid level 7a and 7b. Part of grid level 7a are households and small commercial customers with an electricity demand of up to approx. 300 A and 230/400 V feed-in. Industrial and commercial businesses with an electricity demand above 300 A with a 400 V connection are counted as grid level 7b.

In public power supply, the majority of medium-voltage grids are operated in the 10 kV to 30 kV range. The values vary greatly from country to country, depending on the historical technological development and the local conditions. In urban environments, the spatial supply radius of a medium-voltage grid with 10 kV operating voltage is at approx. 5 to 10 km and in rural areas with 20 kV operating voltage at approx. 10 to 20 km. These are merely guide values. In practice, the supply area strongly depends on local conditions, for example the customer structure (load) and the geographical position.

Apart from the public supply, there are other voltages in industrial plants with medium-voltage grids that depend on the consumers. In most cases, the operating voltages of the installed motors are decisive. Operating voltages between 3 kV and 15 kV are very often used in industrial supply networks.

The network configuration is determined by the respective supply task, the building dimensions, the number of floors above/below ground, the building use as well as the building equipment and power density. Typically, areas of different power densities also require different network configurations. In this context, the reliability of supply and the supply quality of the electric power distribution system should be paid special attention to. An optimal network configuration should meet the following requirements:

- Low investment
- Straightforward network configuration
- High reliability and quality of supply
- Low power losses
- Favourable and flexible expansion options
- Low electromagnetic interference

The following characteristics must be determined for a suitable network configuration:

- Number of supply points
- Size and type of power sources
- Central or distributed installation of the power sources
- Type of meshing and size of the power outage reserve
- Type of connection to earth and neutral-point connection

Grid level 1	Transmission grid	Ultra-high voltage grid	220/380 kV 3~, HVDC up to $\pm 800$ kV DC	Large power stations, wind parks, European interconnected grid
Grid level 2	Main substation	From ultra-high to high voltage		
Grid level 3	Supra-regional distribution grid	High voltage	110 kV 3~	Medium-size power stations, e.g. bio and hydro power stations
Grid level 4	Main substation	High to medium voltage HV/MV		
Grid level 5	Regional distribution grid	Medium voltage	10/20/30 kV 3~	Small power stations, e.g. wind power stations and PV systems
Grid level 6	Transformer substation	Medium to low voltage MV/LV		
Grid level 7	Local low-voltage grid	Low voltage	230 V 1~/400 V 3~	Small power stations, e.g. PV systems, fuel cells

Tab. 2/10: Grid level structure in the UCTE grid (UCTE – Union for the Co-ordination of Transmission of Electricity)

## 2.5 Type of Power Supply

Electrical energy can be fed into the grid in different ways, determined by its primary function (Tab. 2/11). For normal power supply (NPS):

- Direct connection to the public low-voltage grid: in Germany for example up to approx. 300 kW (two times 250 A house connection) at 400/230 V
- Transfer from the medium-voltage grid (max. 52 kV) via public or in-house substations (in Germany mostly with transformers from 0.5 to 2.5 MVA)

For the emergency standby power system (ESPS), power sources are selected based on regulations and as a function of the permissible interruption time:

- Generators for general standby operation and/or safety power supply (SPS)
- Uninterruptible power systems
  - Static UPS comprising a rectifier/inverter unit with battery or flywheel energy storage for buffering voltage failures
  - Rotating UPS comprising a motor/generator set with flywheel energy storage or a battery plus rectifier/inverter unit for bridging

The constellation depicted in Fig. 2/6 with the corresponding description given in Tab. 2/11 has proven itself in infrastructure projects.

Since the circuits for SPS loads must be laid separately, their placement inside the building is relevant for budget considerations. In Germany, certain statutory regulations and specifications are additionally applicable, which demand the functional endurance of cables and wires in case of fire.

In general, circuits for safety purposes routed through fire-threatened areas must be designed fire-resistant. Never must they be routed through explosion-prone areas. Usually, safety-purpose facilities receive an automatic power supply whose activation does not depend on operator action. According to IEC 60364-1 (VDE 0100-100), automatic supply is classified by its maximum change-over time:

- Without interruption: automatic supply which can ensure continuous supply during change-over under defined conditions, e.g. with regard to voltage and frequency fluctuations;
- Very short interruption: automatic supply which is available within 0.15 s;
- Short interruption: automatic supply which is available within 0.5 s;
- Mean interruption: automatic supply which is available within 15 s;
- Long interruption: automatic supply which is available after more than 15 s;

Type	Example
Normal power supply (NPS)	Supply of all installations and power consumers available in the building
Safety power supply (SPS)	Supply of life-protecting facilities in case of danger: <ul style="list-style-type: none"> <li>• Safety lighting</li> <li>• Fire fighting lifts</li> <li>• Fire extinguishing systems</li> </ul>
Uninterruptible power supply (UPS)	Supply of sensitive power consumers which must be operated without interruption in the event of an NPS failure: <ul style="list-style-type: none"> <li>• Emergency lighting</li> <li>• Servers/computers</li> <li>• Communication systems</li> </ul>

Tab. 2/11: Type of supply

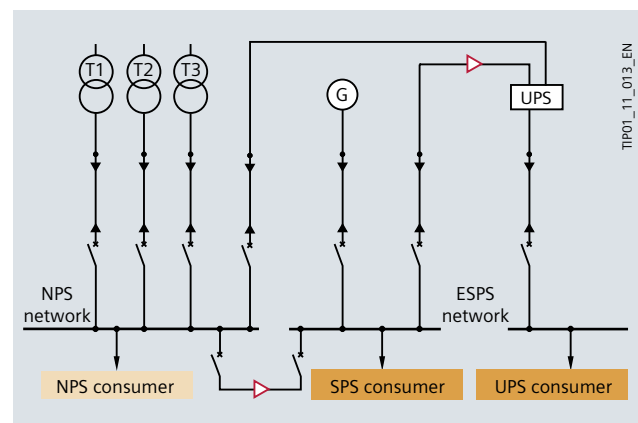

Fig. 2/6: Type of supply

In IEC 60364-5-56 (VDE 0100-560) the following examples of safety installations are given:

- Emergency lighting / safety lighting
- Fire extinguishing pumps
- Fire fighting lifts
- Alarm systems such as fire alarm systems, carbon monoxide (CO) alarm systems, and intruder detection systems
- Evacuation systems
- Smoke evacuation systems
- Important medical systems

The procedure shown in Fig. 2/7 can be carried out by customers and/or planners for a use-specific classification of different power consumers and the associated corporate-sensitive tasks. Criteria for the determination of business-critical processes might for example be the following:

- Effects on life and health
- Protection of important legal interests
- Observance of the law and regulations
- Loss of the institution's / company's reputation

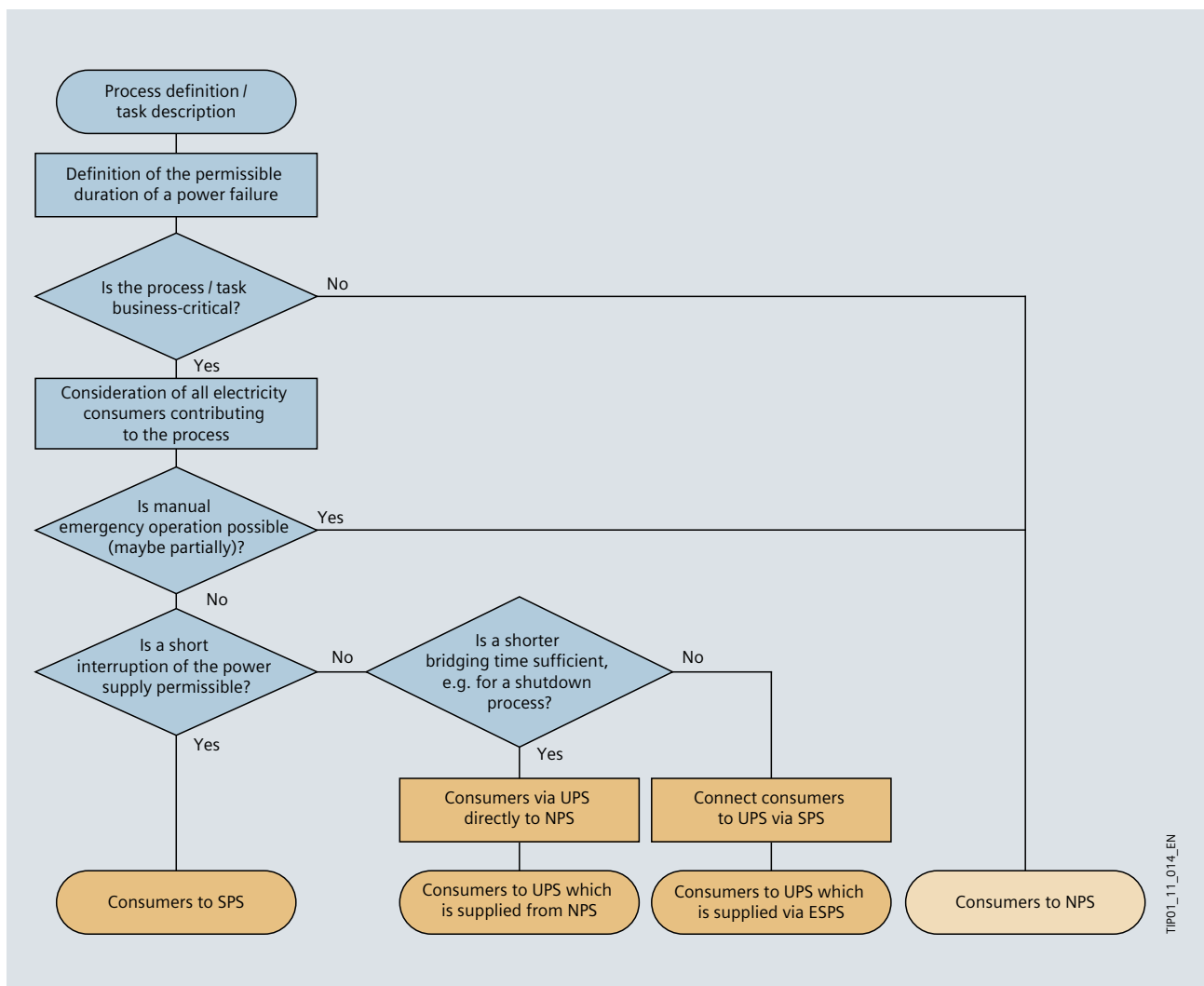

Fig. 2/7: Flowchart for an estimation of NPS, SPS and UPS



## 2.6 Central or Distributed Installation of Low-voltage Supply

Supply design distinguishes between central and distributed supply variants in dependency of spatial conditions and the associated load requirements. In case of a central installation, the transformers, which are concentrated in one place, feed into the different power distribution branch lines. In case of a distributed installation, the transformers are placed at load centres, so that they must be spread over a larger area. Fig. 2/8 shows the intrinsic advantages of distributed as compared to central supply.

If separate substation rooms cannot or shall not be built in an industrial environment, for example, these transformer load centre substations (see Fig. 2/9) provide a compact and easily installable solution for distributed power supply.



Fig. 2/9: SITRABLOC transformer load centre substation

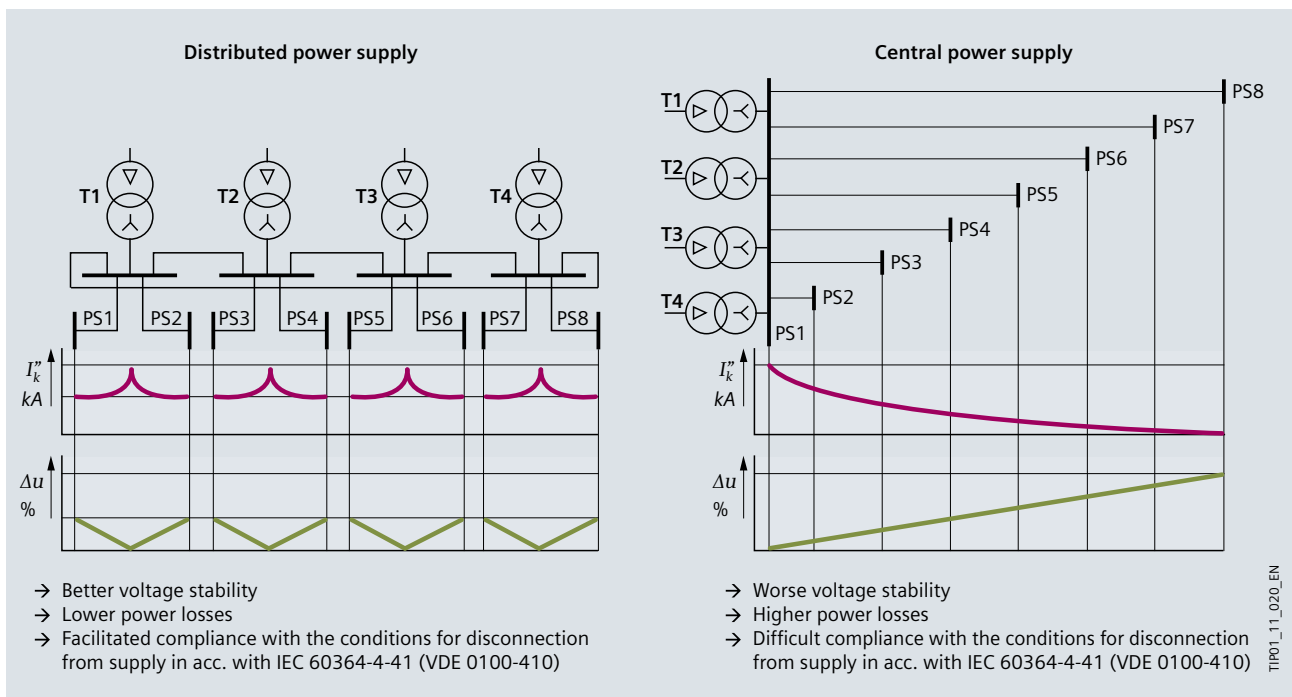

Fig. 2/8: Comparison of supply variants with regard to short-circuit current  $I_k''$  and voltage drop  $\Delta u$

## 2.7 Network Configurations

Starting from the type of supply, electric power distribution grids or networks can also be distinguished according to their type of meshing. The following basic configurations are distinguished:

- Radial networks
- Ringed networks
- Meshed networks

The spur-line-fed radial network (Fig. 2/10) is the most simple form. Its advantages lie in easy monitoring and protection as well as in fast fault localisation and simple operational management. When the expense is doubled, the outcome is a double-spur network. Every load centre can be reached via two different paths. Switching devices are only closed if required. If the requirements placed on supply reliability are high, each supply line can be fed from an independent supply network. Due to fact that the networks are independent from each other, a fault in one network will not affect the other one.

In combination with a ring line as an extension of the spur network (Fig. 2/10), a ringed network can be built up.

Dependent on the spatial structures, the investment to be made for an open-type ringed network can be lower or higher than for a spur network. A spur network is advantageous if individual transformers shall handle low-voltage supply in a confined space. A ringed network can be favourable regarding costs of investment if supply is spread out over a larger area with several transformer centres.

In terms of space requirements, power demand coverage, environmental friendliness and cable costs, the differences between the two network configurations are small. Although ringed networks more often come with shorter cable lengths, the cable cross section must be higher owing to the transmission of higher capacities from one ring endpoint to the other.

With regard to the costs of power losses, the spur network and the open-type ringed network only differ insignificantly. There are minimal advantages if the ringed network is operated in the closed-type variant. However, protection of the closed ring requires circuit-breakers and line differential protection. These additional costs show up in investments.

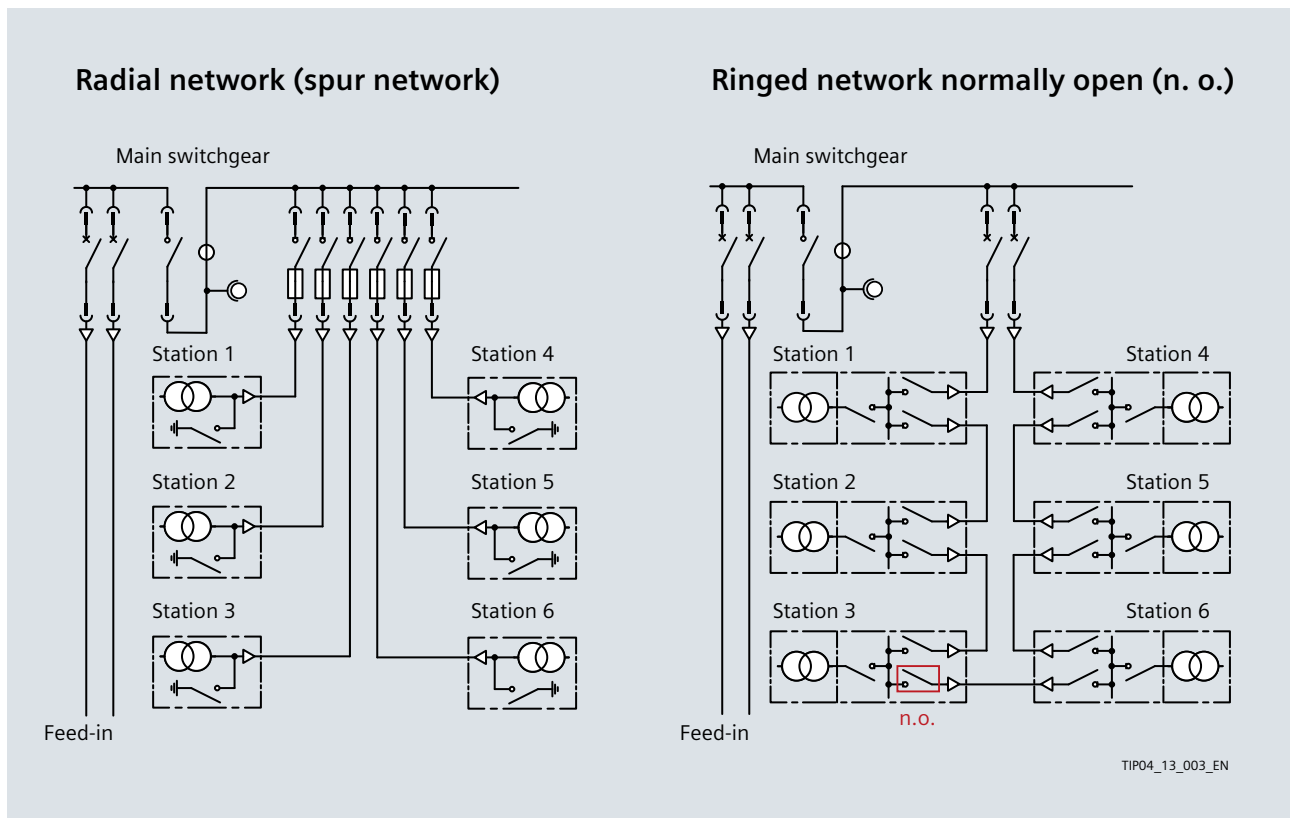

Fig. 2/10: Radial and ringed network for the connection of distributed transformer load centre substations

In case of a cable fault in an open-type ringed network, all stations downward of the fault location up to the normally open switch will fail. In case of low-voltage-side meshing of the ring stations, the failure of a large sub-ring could result in overload and disconnection of non-affected, still operable transformers. Whereas a cable fault in the spur network merely results in the failure of one station.

Only with a closed-typed ringed network and appropriate protection expense could such a level of reliability be also attained in the ringed network. In addition to this, the closed-type ringed network provides an immediate reserve in case of cable faults, whereas the spur network merely offers a load transfer reserve. A single fault with transformer failure can be handled in both networks without interruption if (n-1) redundancy (see chapter 5) applies for the transformers.

Furthermore, operating a ringed network always requires distributed switching operations which hamper ease of operation. Switching operations for fault localisation and actions to attain a defined switching condition in cases of defect are more complicated than with a radial network. Weather-dependent power feed-in of solar and wind power stations increasingly burdens grids owing to fluctuations which can inadequately be planned only. In line with this, safely connecting parts of the network into supply and likewise disconnecting these parts from supply together with a realisation of what is going on are becoming more and more important.

## 2.8 Power Supply Systems according to their Type of Connection to Earth

Suitable power supply systems according to the type of connection to earth are described in IEC 60364-1 (VDE 0100-100). The type of connection to earth must be selected carefully for the medium- or low-voltage network, as it has a major impact on the expense required for protec-

tion measures (Fig. 2/11). On the low-voltage side, it also influences the system's electromagnetic compatibility (EMC). From experience the TN-S system has the best cost-benefit ratio of electric grids at the low-voltage level.

In a TN system, in the event of a short-circuit to an exposed conductive part, a considerable part of the single-pole short-circuit current is not fed back to the power source via a connection to earth but via the protection conductor. The comparatively high single-pole short-circuit current allows

**TN system:** In the TN system, one operating line is directly earthed; the exposed conductive parts in the electrical installation are connected to this earthed point via protection conductors. Dependent on the arrangement of the protection (PE) and neutral (N) conductors, three types are distinguished:

**a) TN-S system:**

In the entire system, neutral (N) and protection (PE) conductors are laid separately.

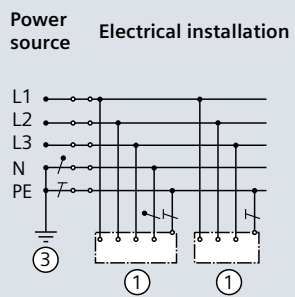

**b) TN-C system:**

In the entire system, the functions of the neutral and protection conductor are combined in one conductor (PEN).

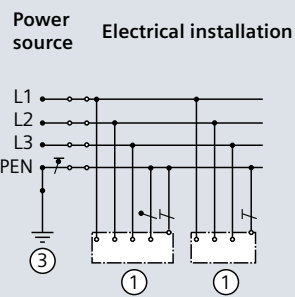

**c) TN-C-S system:**

In a part of the system, the functions of the neutral and protection conductor are combined in one conductor (PEN).

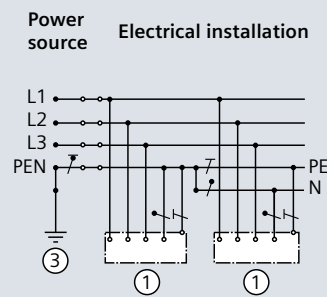

**TT system:** In the TT system, one operating line is directly earthed; the exposed conductive parts in the electrical installation are connected to earthing electrodes which are electrically independent of the earthing electrode of the system.

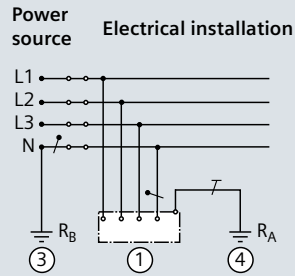

**IT system:** In the IT system, all active operating lines are separated from earth or one point is connected to earth via an impedance.

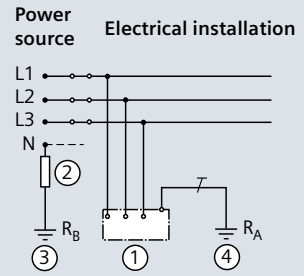

- First letter = earthing condition of the supplying power source
- T = direct earthing of one point (live conductor)
- I = no point (live conductor) or one point of the power source is connected to earth via an impedance
- Second letter = earthing condition of the exposed conductive parts in the electrical installation
- T = exposed conductive parts are connected to earth separately, in groups or jointly
- N = exposed conductive parts are directly connected to the earthed point of the electrical installation (usually N conductor close to the power source) via protection conductors

- Further letters = arrangement of the neutral conductor and protection conductor
- S = neutral conductor function and protection conductor function are laid in separate conductors.
- C = neutral conductor function and protection conductor function are laid in one conductor (PEN).
- ① Exposed conductive part
- ② High-resistance impedance
- ③ Operational or system earthing  $R_B$
- ④ Earthing of exposed conductive parts  $R_A$  (separately, in groups or jointly)

Fig. 2/11: Systems according to the type of connection to earth in acc. with IEC 60364-1 (VDE 0100-100)

TIP01\_11\_019\_EN

for the use of simple protection devices such as fuses or miniature circuit-breakers, which trip in the event of a fault within the permissible tripping time. In building engineering, networks with TN systems are preferably used today. When using a TN-S system in the entire building, residual currents in the building and thus an electromagnetic interference by galvanic coupling can be prevented in normal operation because the operating currents flow back exclusively via the separately laid isolated N conductor (Tab. 2/12). In case of a central arrangement of the power sources, we always recommend the TN system as a rule. In that, the system earthing is implemented at one central earthing point (CEP), for example in the low-voltage main distribution system, for all sources.

Please note that neither the PEN nor the PE must be switched. If a PEN conductor is used, it is to be insulated over its entire course – this includes the distribution system. The magnitude of the 1-pole short-circuit current directly depends on the position of the CEP.

*Caution: In extensive supply networks with more than one splitter bridge, stray short-circuit currents may occur.*

Characteristics	TN-C			TN-C/S			TN-S			IT system			TT system		
	1	2	3	1	2	3	1	2	3	1	2	3	1	2	3
Low cost of investment	1	1	1	1	2	3	1	2	3	1	2	3	1	2	3
Little expense for system extensions	1	1	1	1	2	3	1	2	3	1	2	3	1	2	3
Any switchgear / protection technology can be used	1	1	1	1	2	3	1	2	3	1	2	3	1	2	3
Earth-fault detection can be implemented	1	1	1	1	2	3	1	2	3	1	2	3	1	2	3
Fault currents and impedance conditions in the system can be calculated	1	1	1	1	2	3	1	2	3	1	2	3	1	2	3
Stability of the earthing system	1	1	1	1	2	3	1	2	3	1	2	3	1	2	3
High degree of operational safety	1	1	1	1	2	3	1	2	3	1	2	3	1	2	3
High degree of protection	1	1	1	1	2	3	1	2	3	1	2	3	1	2	3
High degree of shock hazard protection	1	1	1	1	2	3	1	2	3	1	2	3	1	2	3
High degree of fire safety	1	1	1	1	2	3	1	2	3	1	2	3	1	2	3
Automatic disconnection for protection purposes can be implemented	1	1	1	1	2	3	1	2	3	1	2	3	1	2	3
EMC-friendly	1	1	1	1	2	3	1	2	3	1	2	3	1	2	3
Equipment functions maintained in case of 1 <sup>st</sup> earth or enclosure fault	1	1	1	1	2	3	1	2	3	1	2	3	1	2	3
Fault localisation during system operation	1	1	1	1	2	3	1	2	3	1	2	3	1	2	3
Reduction of system downtimes by controlled disconnection	1	1	1	1	2	3	1	2	3	1	2	3	1	2	3

1 = true 2 = conditionally true 3 = not true

Tab. 2/12: Exemplary quality rating dependent on the power supply system according to its type of connection to earth

1  
2 4-pole switches must be used if two TN-S subsystems are connected to each other. In TN-S systems, only one earthing bridge may be active. Therefore it is not permitted that two earthing bridges be interconnected via two conductors.

3 Today, networks with TT systems are only used in rural supply areas and in few countries. In this context, the stipulated independence of the earthing systems must be observed. In accordance with IEC 60364-5-54 (VDE 0100-540), a minimum clearance  $\geq 15$  m is required.

4  
5 Networks with an IT system are preferably used for rooms with medical applications in accordance with IEC 60364-7-710 (VDE 0100-710) in hospitals and in production, where no supply interruption is to take place upon the first fault, for example in the cable and optical waveguide production. The TT system as well as the IT system require the use of residual current devices (RCDs) – previously named FI (fault current interrupters) – for almost all circuits.

8

9

10

11

12

13

14

15

16

17

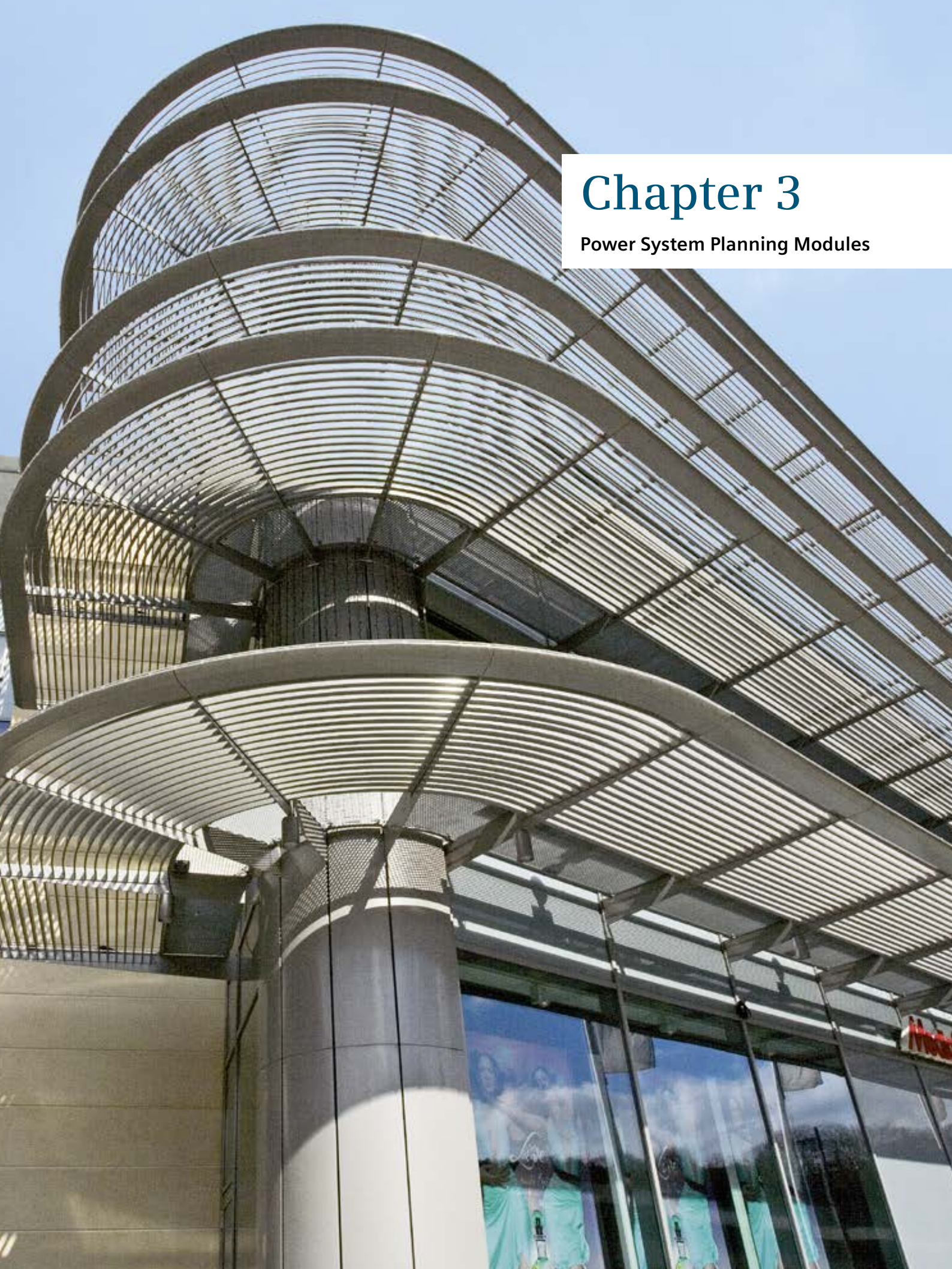

# Chapter 3

Power System Planning Modules

# 3 Power System Planning Modules

Power system planning modules can be used for an easy and systematic power distribution design for typical building structures. These are schematic solution concepts which clarify the spatial arrangement and connection of important components for electric power distribution. The modules shown below are suggestions for the planning of various building types and supply options. All modules are based on a clear radial network and the following goals are aimed at:

- High reliability of operation and supply
- Good electromagnetic compatibility
- Selectivity

100 % of the total power are drawn from the public grid, whereof 10 to 30 % are provided for the safety power supply (SPS) and 5 to 20 % for the uninterruptible power supply (UPS). For medium-voltage supply, an SF<sub>6</sub> gas-insulated 8DJH medium-voltage switchgear, a SIVACON low-voltage main distribution system with TN-S system, and – due to the room conditions – GEAFOL cast-resin transformers with reduced losses are assumed for the modules.

The room conditions and the associated load requirements are essential for the basic concept. The flow diagram Fig. 3/1 shows, how a systematic analysis of the boundary conditions and the different single decisions lead to a planning framework which helps the planner find the right supply concept for his project.

The design proposals (Tab. 3/1) and the network planning modules (Fig. 3/2 to Fig. 3/6) help building up the power distribution system for typical building structures in an easy and systematic way. The schematized solution proposals can then be specifically extended and adjusted for a project. When the preliminary planning stage has been completed, the power system can easily be dimensioned and calculated with the aid of the SIMARIS design planning tool. Up-to-date and detailed descriptions of selected applications can be obtained on the Internet at

[siemens.com/tip-cs/planningmanuals](http://siemens.com/tip-cs/planningmanuals)

Module	Building type	Supply	Wiring/ main route	Floors	Floor area	Total area	Power required	Transformer module	Generator	UPS
1	Low-rise building	1 supply section	Cable	≤4	2,500 m <sup>2</sup>	10,000 m <sup>2</sup>	1,000 – 2,000 kW	2 × 630 kVA, u <sub>kr</sub> = 6%, I <sub>k</sub> ≤ 30 kA	400 kVA (30%)	200 kVA (15%)
2	Low-rise building	2 supply sections	Busbar	≤4	2,500 m <sup>2</sup>	2 × 10,000 m <sup>2</sup>	> 2,000 kW	2 × 800 kVA, u <sub>kr</sub> = 6%, I <sub>k</sub> ≤ 60 kA	730 kVA (30%)	400 kVA (15%)
3	High-rise building	1 supply section, central	Busbar	≤10	1,000 m <sup>2</sup>	10,000 m <sup>2</sup>	≤1,800 kW	2 × 630 kVA, u <sub>kr</sub> = 6%, I <sub>k</sub> ≤ 30 kA	400 kVA (30%)	200 kVA (15%)
4	High-rise building	1 supply section, transformers at remote location	Cable	10–20	1,000 m <sup>2</sup>	20,000 m <sup>2</sup>	≤1,500 kW	2 (2 + 1) × 630 kVA, u <sub>kr</sub> = 6%, I <sub>k</sub> ≤ 45 kA	800 kVA (30%)	400 kVA (15%)
5	High-rise building	Distributed supply	Busbar	>20	1,000 m <sup>2</sup>	20,000 m <sup>2</sup>	≥2,000 kW	2 × 3 × 800 kVA, u <sub>kr</sub> = 6%, I <sub>k</sub> ≤ 60 kA	2 × 630 kVA (30%)	2 × 300 kVA (15%)

Tab. 3/1: Design suggestions for the various building modules



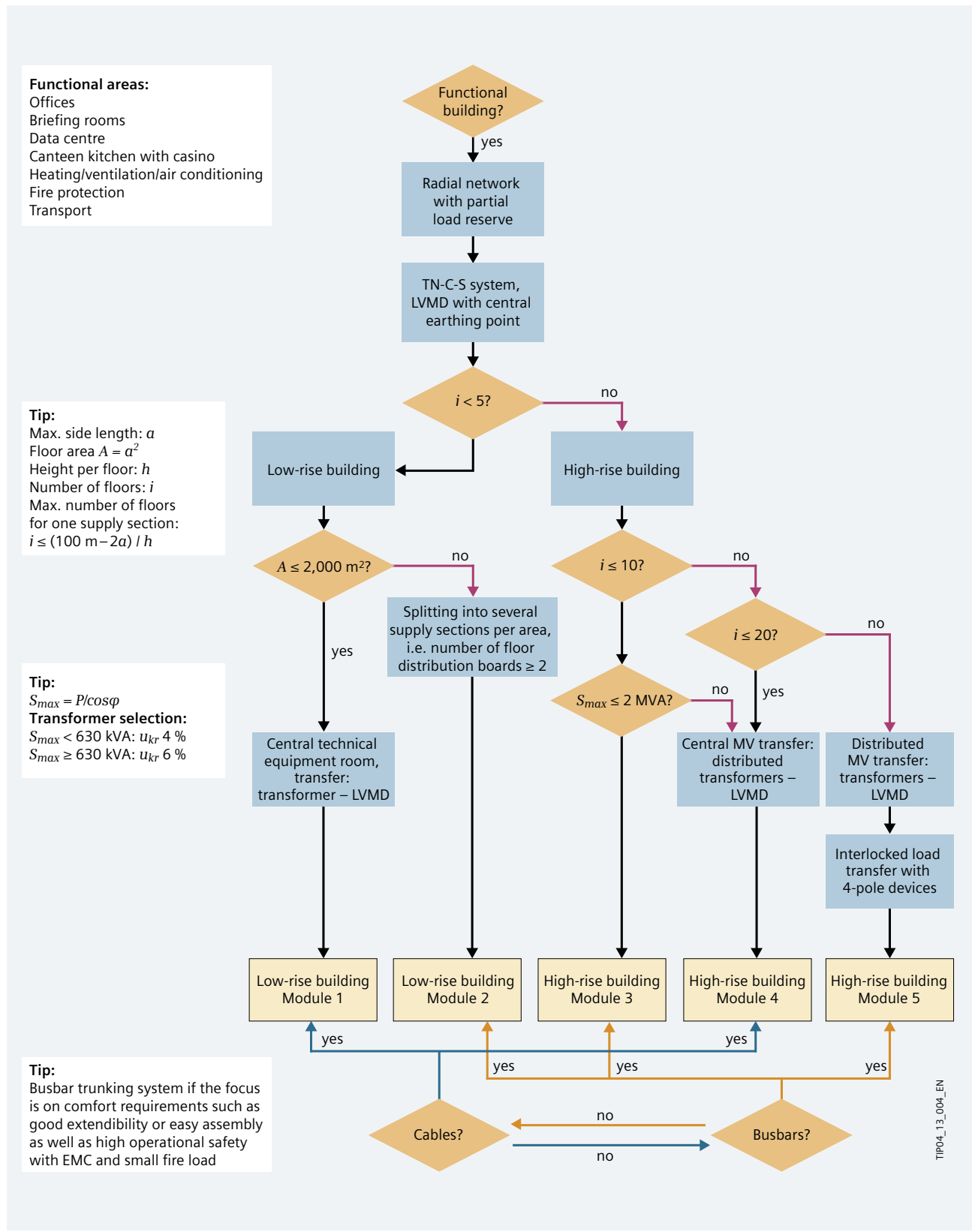
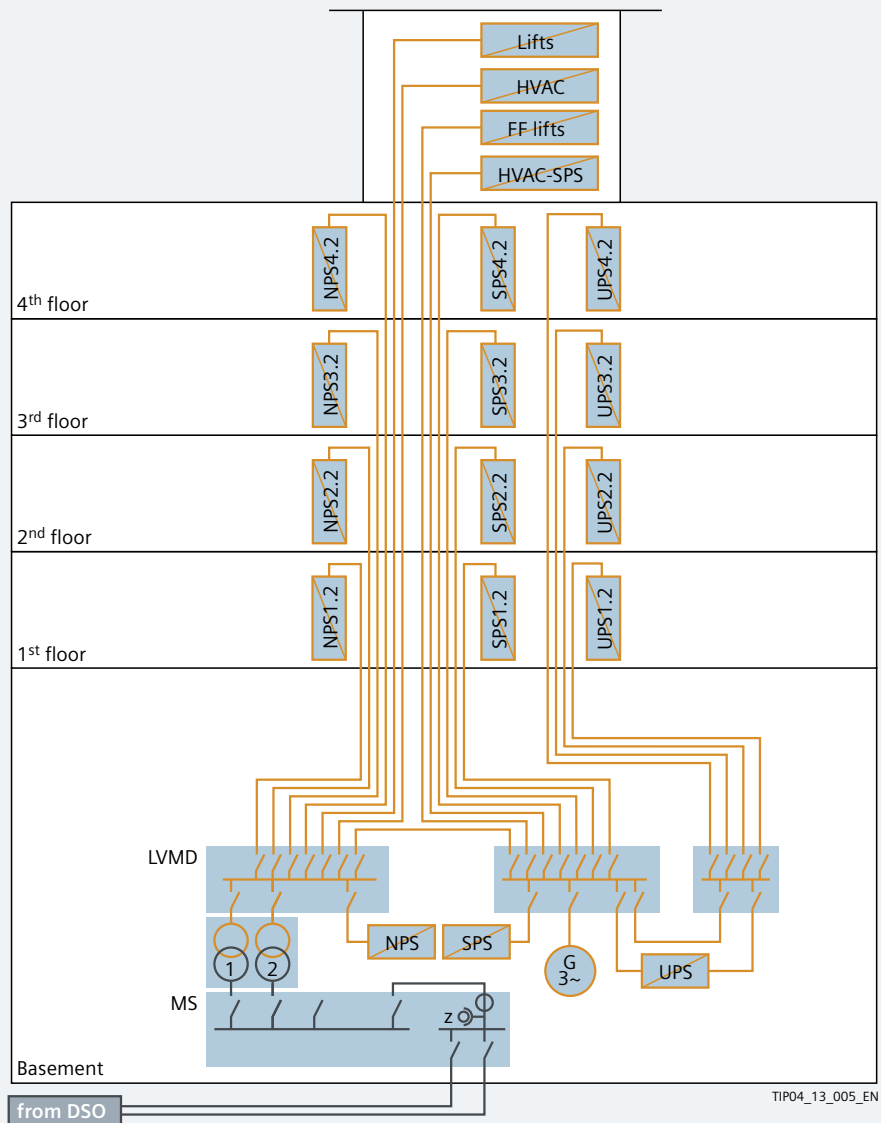

Fig. 3/1: Overview of the network planning concepts

Low-rise building, cable, one central supply section



TIP04\_13\_005\_EN

- NPS Normal power supply
- PCO Power company or system operator
- FF Firefighters
- HVAC Heating – Ventilation – Air conditioning
- MS Medium-voltage switchgear
- LVMD Low-voltage main distribution
- SPS Safety power supply
- UPS Uninterruptible power supply
- DSO Distribution system operator
- z Power monitoring system

Fig. 3/2: Module 1: Low-rise building, cable, one central supply section

Low-rise building, busbar, two central supply sections

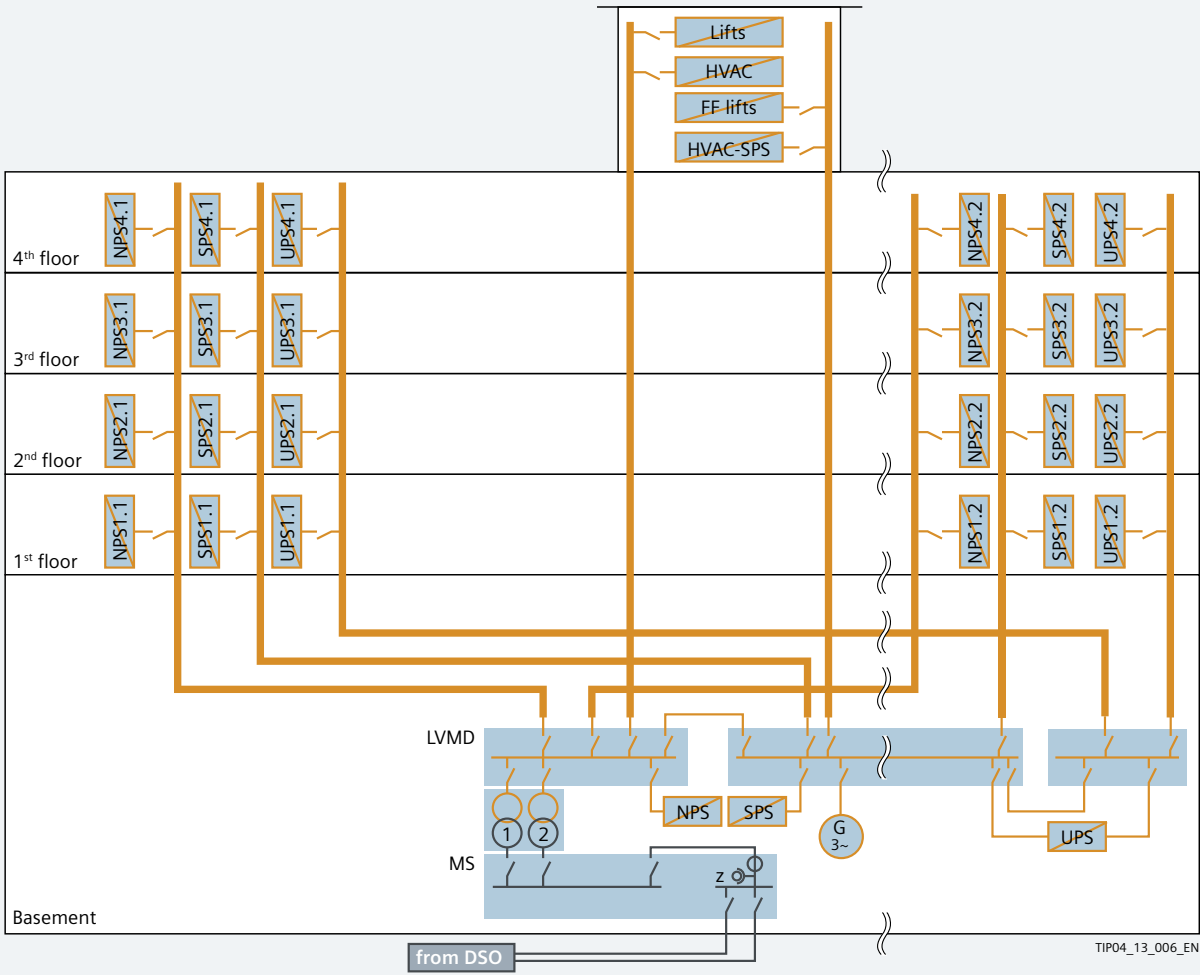

- NPS Normal power supply
- FF Firefighters
- HVAC Heating – Ventilation – Air conditioning
- MS Medium-voltage switchgear
- LVMD Low-voltage main distribution
- SPS Safety power supply
- UPS Uninterruptible power supply
- DSO Distribution system operator
- z Power monitoring system

Fig. 3/3: Module 2: Low-rise building, busbar, two central supply sections

High-rise building, busbar, one central supply section

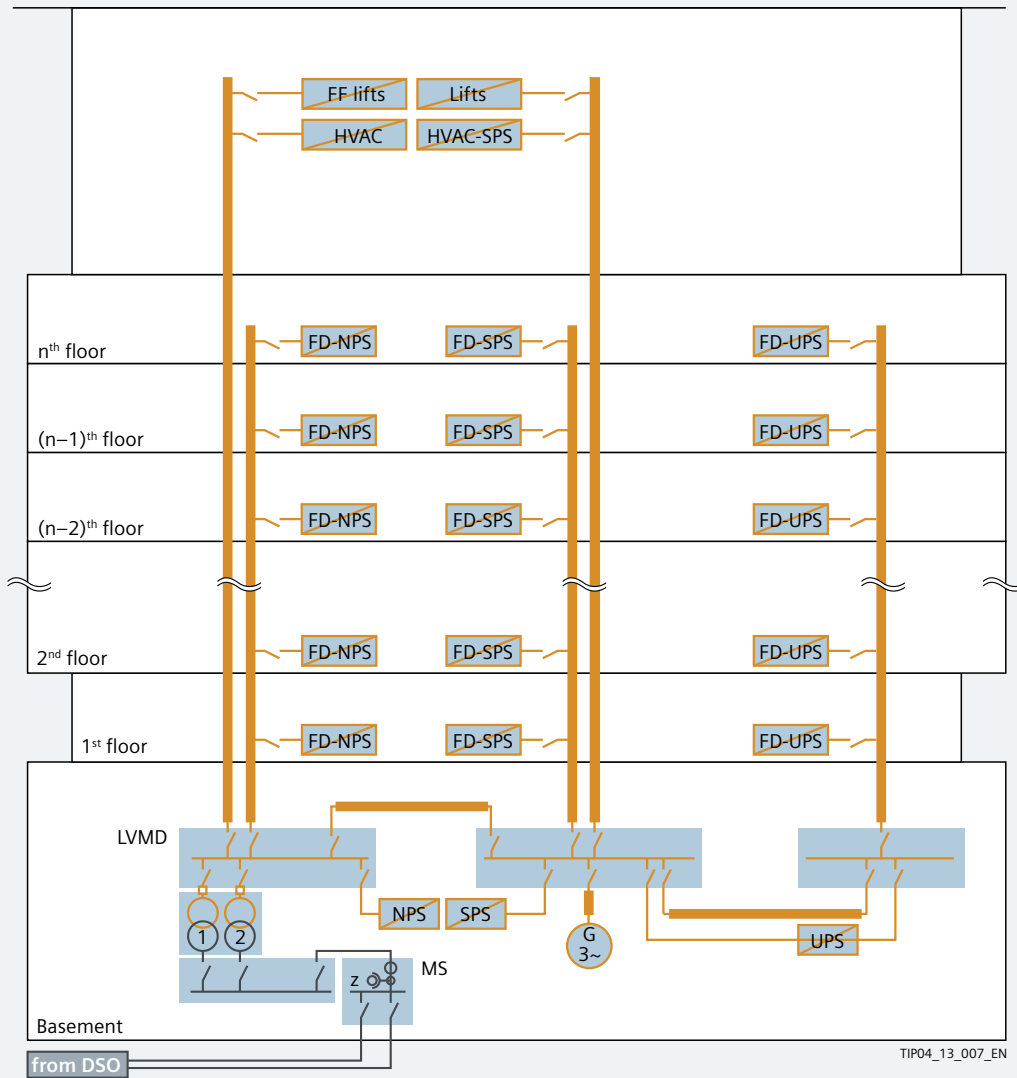

- NPS Normal power supply
- FD Floor distribution boards
- FF Firefighters
- HVAC Heating – Ventilation – Air conditioning
- MS Medium-voltage switchgear
- LVMD Low-voltage main distribution
- SPS Safety power supply
- UPS Uninterruptible power supply
- DSO Distribution system operator
- z Power monitoring system

Fig. 3/4: Module 3: Low-rise building, cable, one central supply section

High-rise building, cable, one supply section, transformers at remote location

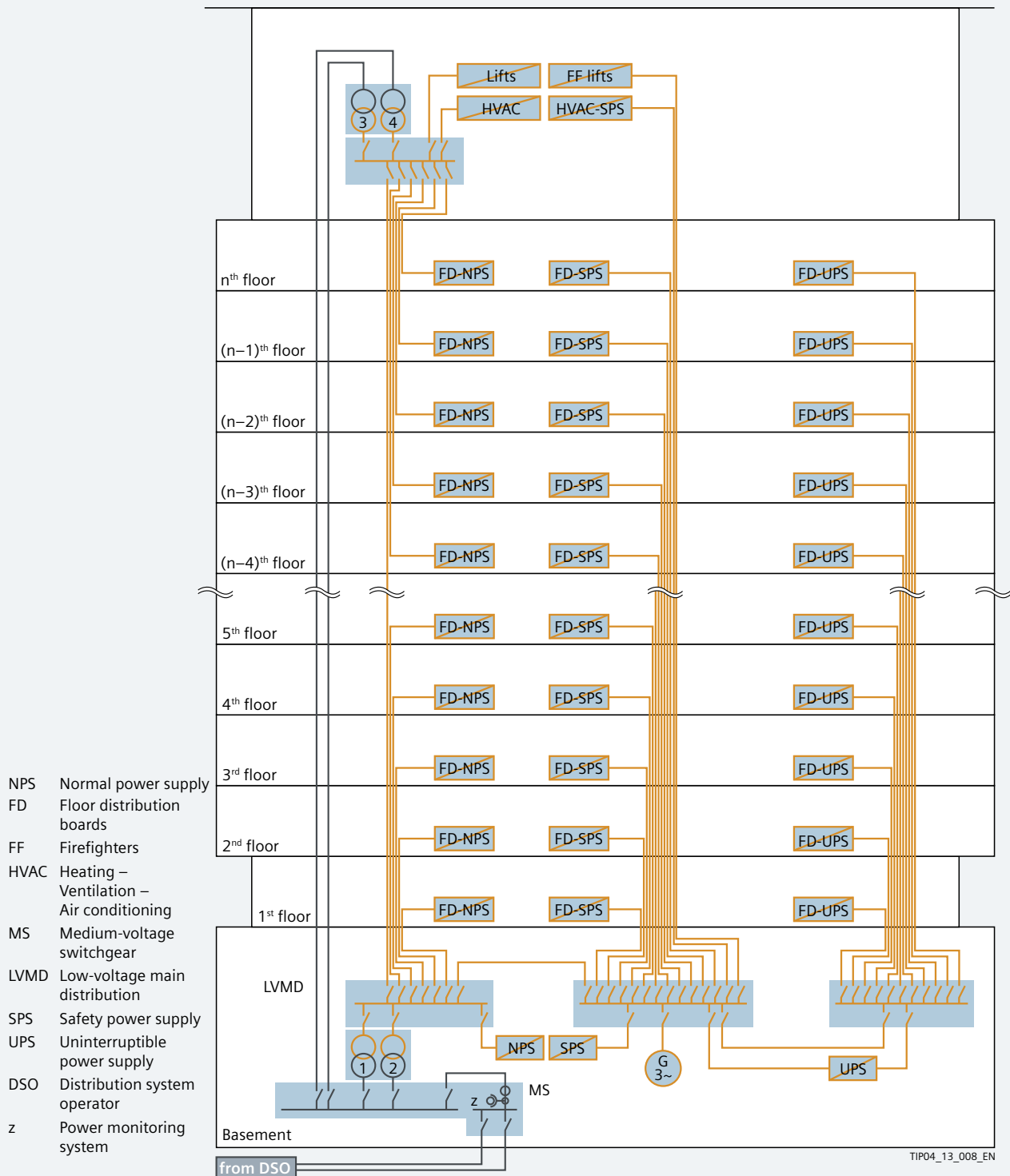

Fig. 3/5: Module 4: High-rise building, cable, one supply section, transformers at remote location

High-rise building, busbar, distributed power supply

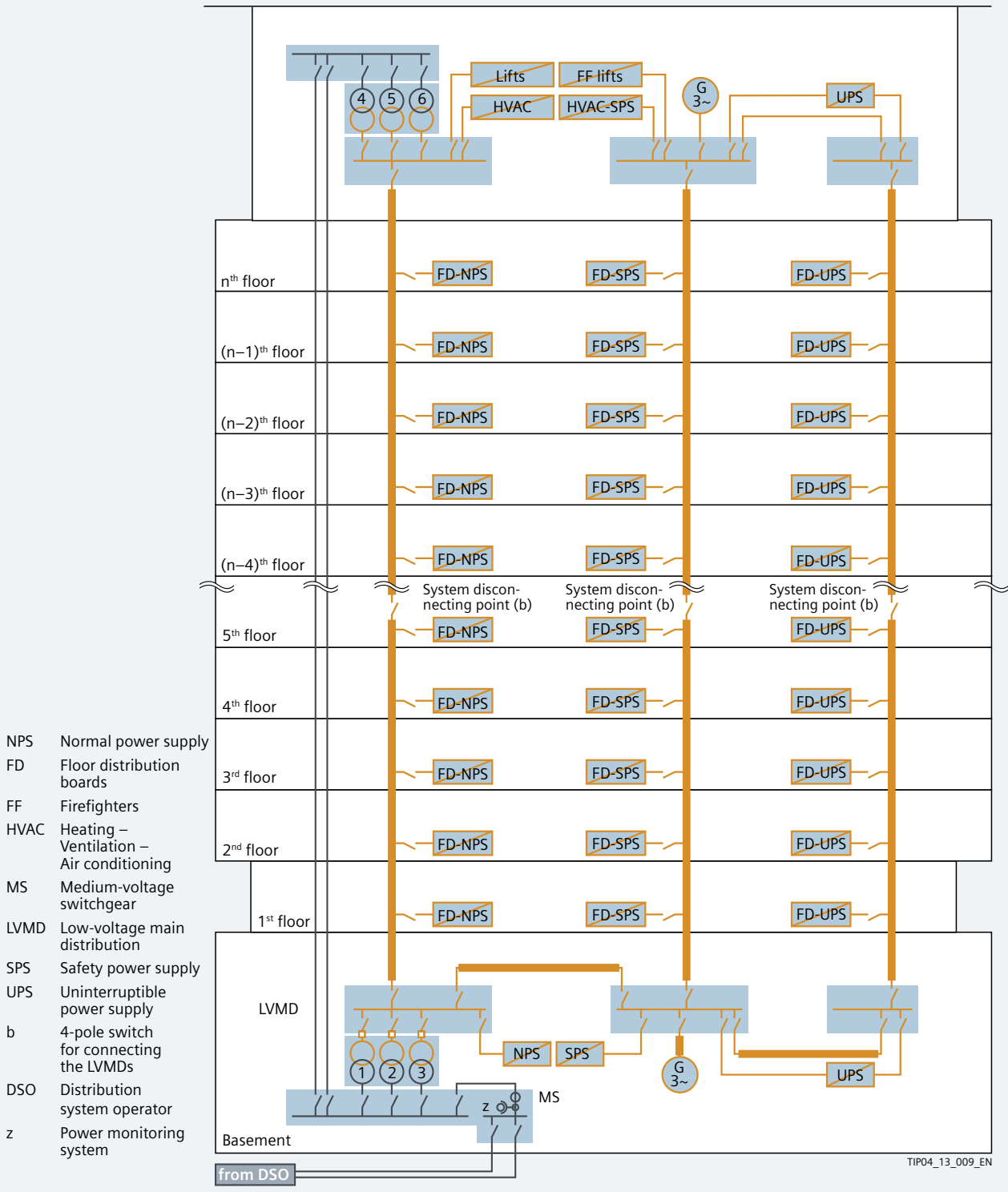
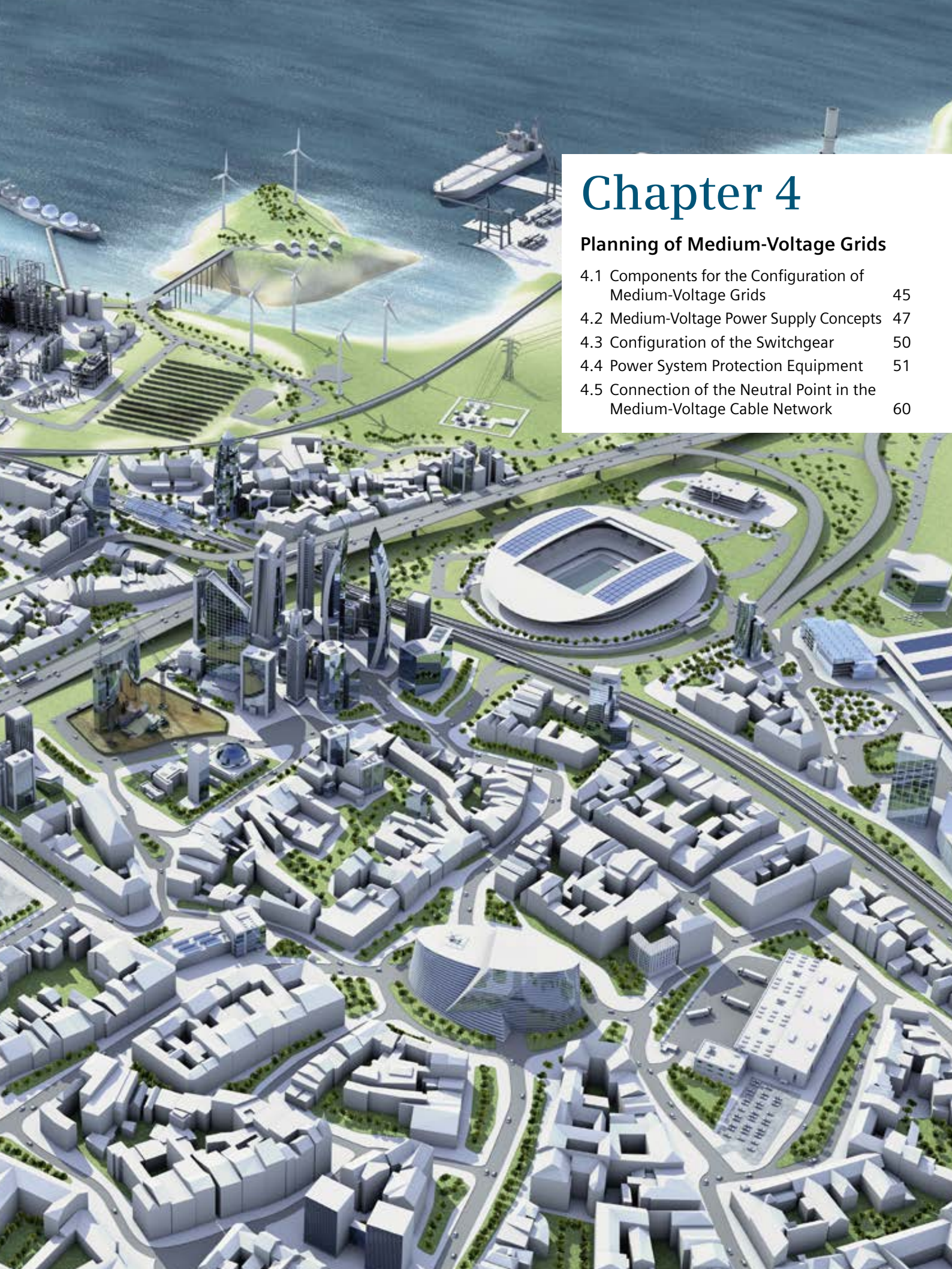

Fig. 3/6: Module 5: High-rise building, busbar, energy center and remote distribution



# Chapter 4

## Planning of Medium-Voltage Grids

4.1 Components for the Configuration of Medium-Voltage Grids	45
4.2 Medium-Voltage Power Supply Concepts	47
4.3 Configuration of the Switchgear	50
4.4 Power System Protection Equipment	51
4.5 Connection of the Neutral Point in the Medium-Voltage Cable Network	60

## 4 Planning of Medium-Voltage Grids

As described in chapter 3, a single medium-voltage substation with one point of supply from the network operator and one or more distribution transformers for supply of the low-voltage loads is not sufficient in large infrastructure projects. Instead, an internal, separately operated medium-voltage system with several substa-

tions is required. The reasons for this, for example, are the high load concentrations in different areas of a large building complex, such as data centres and high-rise buildings used in the infrastructure, or also the distribution of loads over large areas, such as airports, industrial plants, production plants, and hospitals.





## 4.1 Components for the Configuration of Medium-Voltage Grids

In order to be able to fulfil the required tasks at all times, it may be necessary to plan the supply of the power consumers via one or more medium-voltage main stations that serve as consumer substations of the grid operators. Depending on the amount of power required, these main stations can become a main substation from high voltage (HV) to medium voltage (MV) (grid level 4 in Tab. 2/10).

Because of the cost benefits of purchasing power from the high-voltage level, supply from a separate main substation or high-voltage transformer should typically be taken into consideration for a power requirement as of 20 MW. The following must be considered with regard to the components and configuration of medium-voltage grids:

### Main substations, main supplies

1. The configuration of main substations and main supplies should be "inherently safe". This means that if an HV/MV transformer or an MV feeding line should fail, the connected loads have to be switched to another main substation or other points of supply. However, on the one hand the power available to the switchable loads is limited in the medium-voltage grid, and on the other hand there is a danger of maloperations and as a result, failure of parts of the supplied network. By keeping the number of switching operations as low as possible, the total time until the power is restored to the loads is minimised.
2. In order to limit the short-circuit power in the medium-voltage grid, the transformers of the main substations should not be operated in parallel. It is better they are allocated to separate subnetworks.
3. The switchgear in the main substations and main supplies should be short-circuit proof with regard to the installations for the embedded generation and emergency power supply in the MV grid.
4. The installation of main substations and main supplies at the load centres corresponds to a radial supply from the main substations and short distances to the load centres. This enables losses to be minimised, a simple and flexible network configuration as well as an economic network extension.

### Structure of the medium-voltage grid

1. The supply cables and distribution cables are led out radially from a load centre in the first sections. Cables should not be routed tangential to the point of supply because energy flows tangential to the supply direction are an unnecessary transport of energy and cause power losses. Wherever possible, the loads should be supplied from the closest electric (and usually the closest geographic) network node, switchgear or main substation. A similar configuration of individual MV subnetworks with a few standardised network configurations, lines or rings makes the system easier to understand during normal operation or when a fault occurs and reduces the probability of maloperations or unwanted system states.
2. A load flow-optimised network separation and also the possibility of automation and remote control technology should be taken into account for the operation of MV grids, and also the accessibility of stations in order to minimise the downtimes when a fault occurs.
3. In order to ensure the supply quality in the distribution network, the supply radii must be considered in relation to the supply voltage. The rule of thumb is:
  - For a high load density, the supply radius  $r$  in km =  $\frac{1}{3}$  supply voltage in kV
  - For a low load density, the supply radius  $r$  in km =  $\frac{1}{2}$  supply voltage in kV (for example, for a low load density and a supply radius of approximately 5 km, a voltage of 10 kV should be selected, whereas for a high load density, the voltage should be 15 kV or possibly 20 kV).

### Substations

1. If different transformer sizes are used in the substations, only a few standard types should be used.
2. For cost reasons, transformers in substations up to 630 kVA are usually connected via switch-disconnectors and HV HRC fuses. With high transformer outputs, circuit-breakers are used for reasons of selectivity or when automation is required.

3. The economically sensible power range (influence on voltage drop, power losses, power quality) for energy transport in a low-voltage grid of 400 V is between 50 kVA (approx. 72 A) and 250 kVA (approx. 360 A; several low-voltage cables are required in one direction). For a larger power range, the construction of a new substation should be considered.

4. Substations as multiple nodes make the search for a fault more difficult. The load flow and the utilisation of the cable may be unclear. This can even happen during normal operation. Multiple nodes also make an extension of the network more difficult as there is often no clear assignment to lines or rings. As far as possible, the substation should be clearly assigned to a main substation or main feed-in point.

5. For monitoring and control of the loads, communicative instrumentation should be installed on the MV or LV side of the substation. In this way, the power management requirements according to the ISO 50001 standard can be satisfied.

#### Switchgear and cable connections

1. As few switchgear units as possible in the network nodal points with a large number of distribution cables and a small number of supply cables contribute to a simpler orientation and an economic network configuration.

2. The type of switchgear – whether single or double busbar with longitudinal and/or transversal busbar coupler – depends on the network configurations implemented in the network and the network mode of operation during normal operation and when a fault occurs.

3. Feeder cables are transmission cables that connect the transformer substations with one another and to the higher network level. They are usually connected via circuit-breakers with differential protection in the power distribution of infrastructure projects. Distance protection is usually used by public grid operators.

4. Distribution cables connect the substations to the main substation or the main supply. The substations are usually connected via switch-disconnector. If there are special requirements with regard to the supply safety, circuit-breakers with the appropriate protection technology are also used in the infrastructure. In normal operation, the distribution cables are not used as transmission cables.

5. Use uniform, short-circuit-proof cables such as 120 mm<sup>2</sup> Cu or 150 mm<sup>2</sup> Al for distribution cables and 240 mm<sup>2</sup> Cu or 300 mm<sup>2</sup> Al for transmission cables.

6. Avoid routing several cable systems together, if possible, distribute the lines over the area. The combination of distribution cables into cable harnesses with several systems over a few routes results in mutual heating and therefore restricted transmission capacity. This also increases the probability that several cable systems will be damaged at the same time during excavation work.

#### Power generating plants

1. The power generating plants that are to be incorporated, such as combined heat and power stations (CHP), diesel generator units, gas turbines, wind power stations, and solar systems, should be assigned functions, such as standby power supply, emergency power supply, base load coverage, capping of peak loads. The respective function and the installation sites of power generating plants (centrally or distributed in relation to the main feed-in) have a significant effect on the MV network configuration and the required power system protection.

2. Depending on the design, power generating plants can increase the network short-circuit rating; this can be taken into account when dimensioning the switchgear and equipment. Particularly for operation parallel to the public MV grid, there must be agreement with the DSO, and additional measures, such as the use of an  $I_s$  limiter<sup>1</sup>, may be necessary.

3. Power generating plants can have a negative effect on the power system and power quality. Examples of this are voltage changes, harmonics, and flicker (see chapter 5).

<sup>1</sup> Switching device that shuts down within a few milliseconds when a short circuit occurs.

## 4.2 Medium-Voltage Power Supply Concepts

The essential prerequisite for compliance with the previously described planning aspects is a simple, clearly structured network topology that is adapted spatially to the load centres. The main network configurations to illustrate this are described below. The main substations and the transformers required for the supply are shown in Fig. 4/1 to Fig. 4/8. The main supplies can also be pure cable supplies from the public grid (directly from the main substation of the grid operator). The substations displayed are mainly used to distinguish between the transmission and distribution cables and do not represent the amount required for the load.

### Spurs (Fig. 4/1)

In spurs, the distribution transformers are connected individually directly to the switchgear of the point of supply, even over several hundred metres. This makes sense if only a limited number of substations is required and the wiring expense compared to the usual rings with additional MV switchgear is not too large. As only the output of one transformer flows through the cable, the protection against overload is not the critical dimensioning criterion, rather the protection against short circuit. Failure of the cable is the same as failure of the transformer.

### Double spurs (Fig. 4/2)

In double spurs, two parallel, individually protected cables supply a common substation. It can also be considered as a ring with one substation, whereby both cables are connected to different busbar sections. The cables have (nearly) the same length and each carries at maximum 50% of the load.

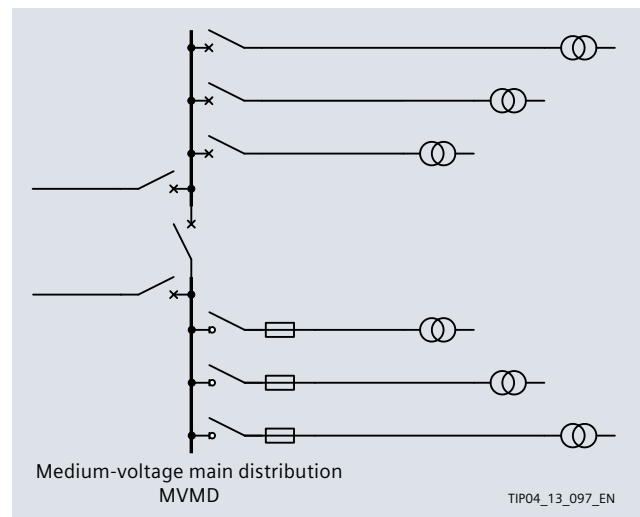

Fig. 4/1: Network configuration: spurs

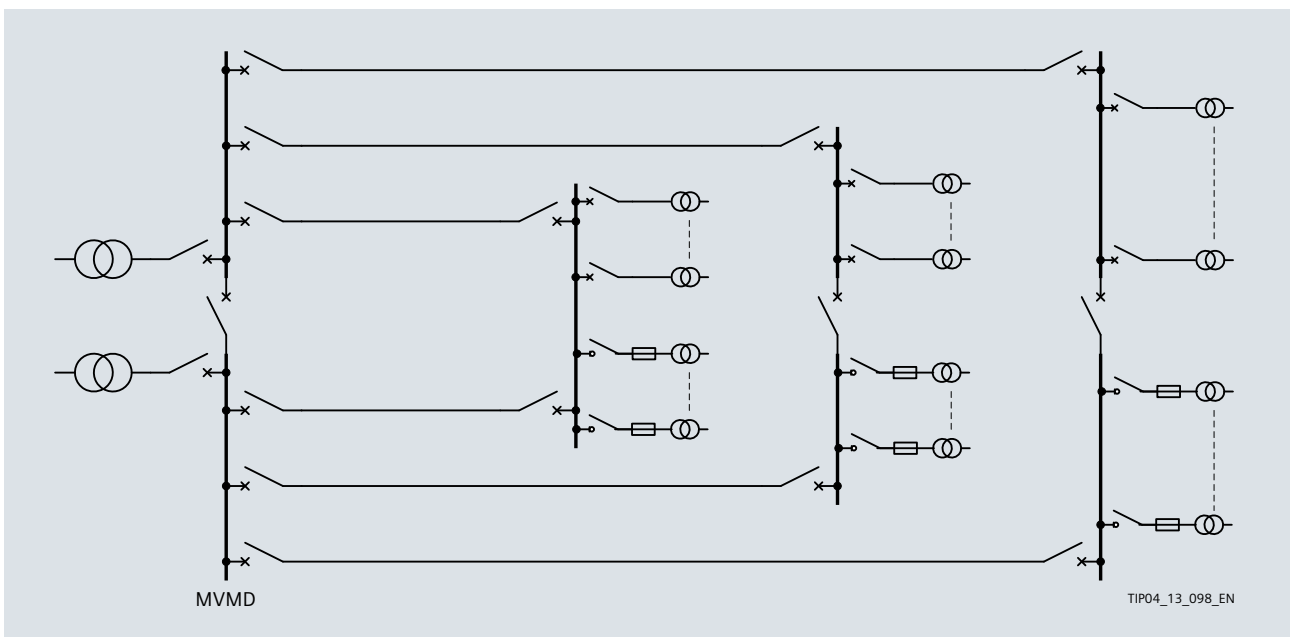

Fig. 4/2: Network configuration: double spurs

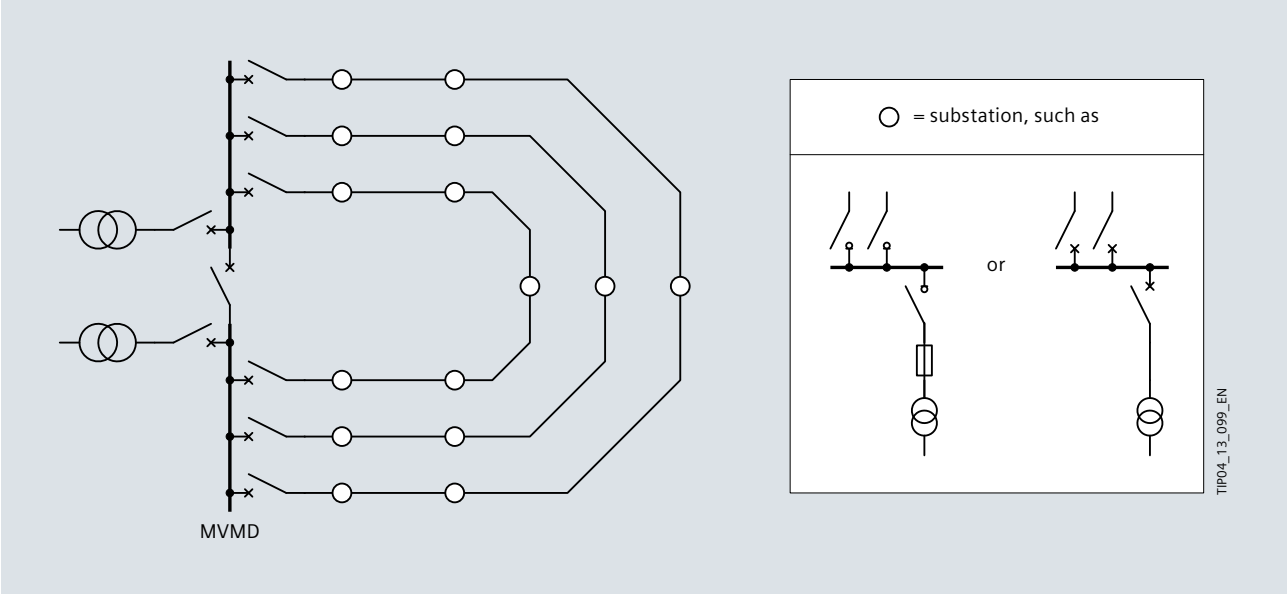

Fig. 4/3: Network configuration: rings

**Rings (Fig. 4/3)**

Rings start and end in the same main substation or in the main feed-in point, but on different busbar sections. The reserve power is guaranteed through the maximum permissible utilisation of a half ring of 50 to 60%.

**Lines (Fig. 4/4)**

Lines start in the main substation or in the main feed-in point and end in the same remote station. A reserve power with 100% of a line is guaranteed through a reserve cable (empty line without substations).

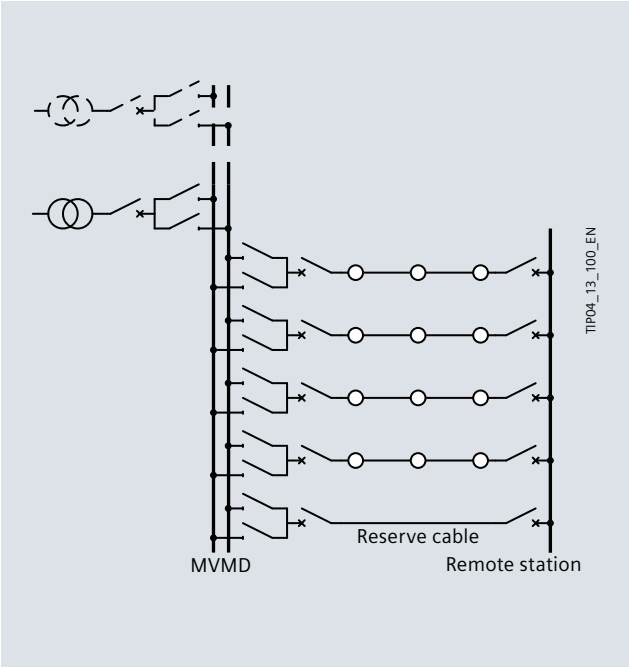

Fig. 4/4: Network configuration: lines with remote station

**Lines with load-centre substation (Fig. 4/5)**

The supply of a load centre without main substation or without main feed-in point requires feeder cables without substations with cross sections  $\geq 240 \text{ mm}^2 \text{ Cu}$  or  $\geq 300 \text{ mm}^2 \text{ Al}$  and immediate reserve for the switchgear. The maximum connected load is determined through the transmission capacity of (n-1) feeder cables. The feeder cables also provide the reserve power for the lines.

**Coupling of two main substation areas (Fig. 4/6)**

If two main substation areas are coupled via a common remote station with busbar coupler longitudinal (BCL), a reserve cable is required for each area, which avoids a coupling of the main substation supply or main feed-in when a fault occurs.

Generally, the network configurations according to Fig. 4/3 to Fig. 4/6 are found in the public supply. Networks for the infrastructure area are generally structured similar to Fig. 4/1 to Fig. 4/3 or from a mix of these three network configurations.

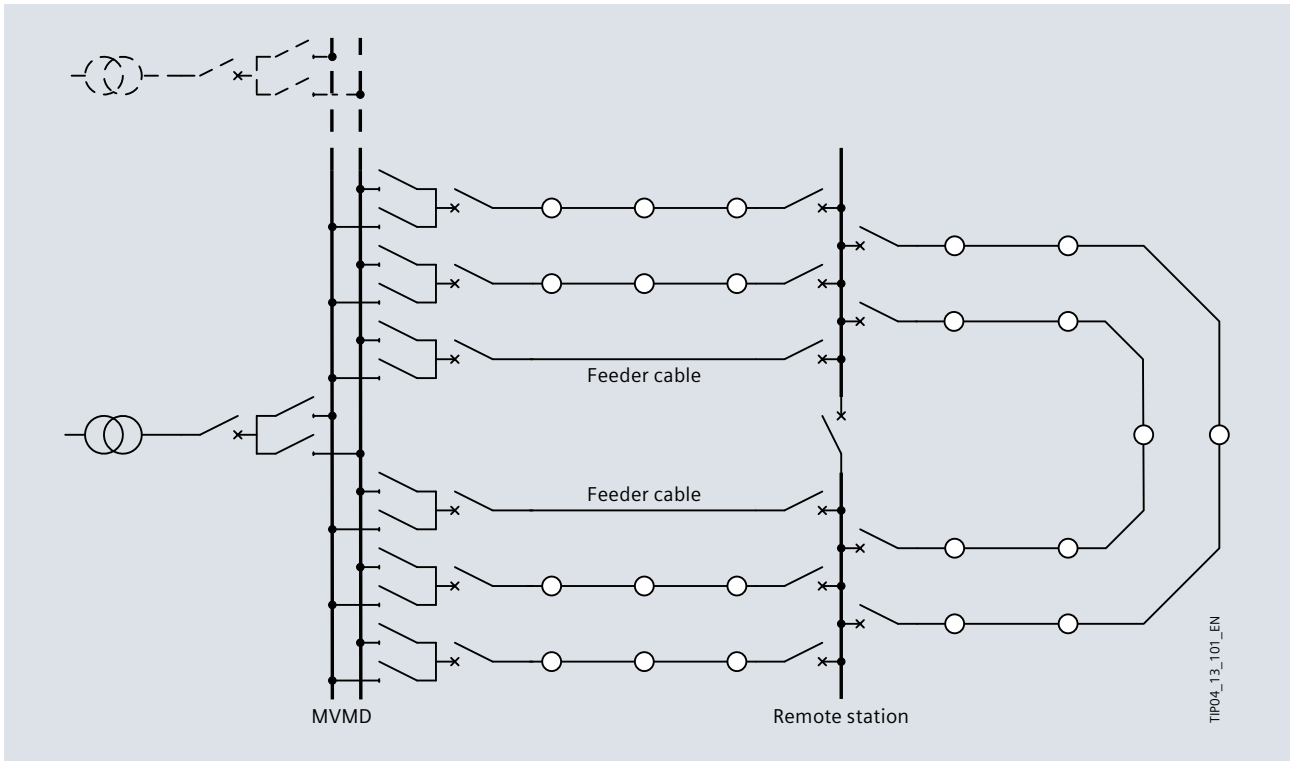

Fig. 4/5: Network configuration: lines with load-centre substation

[back to page 48](#)

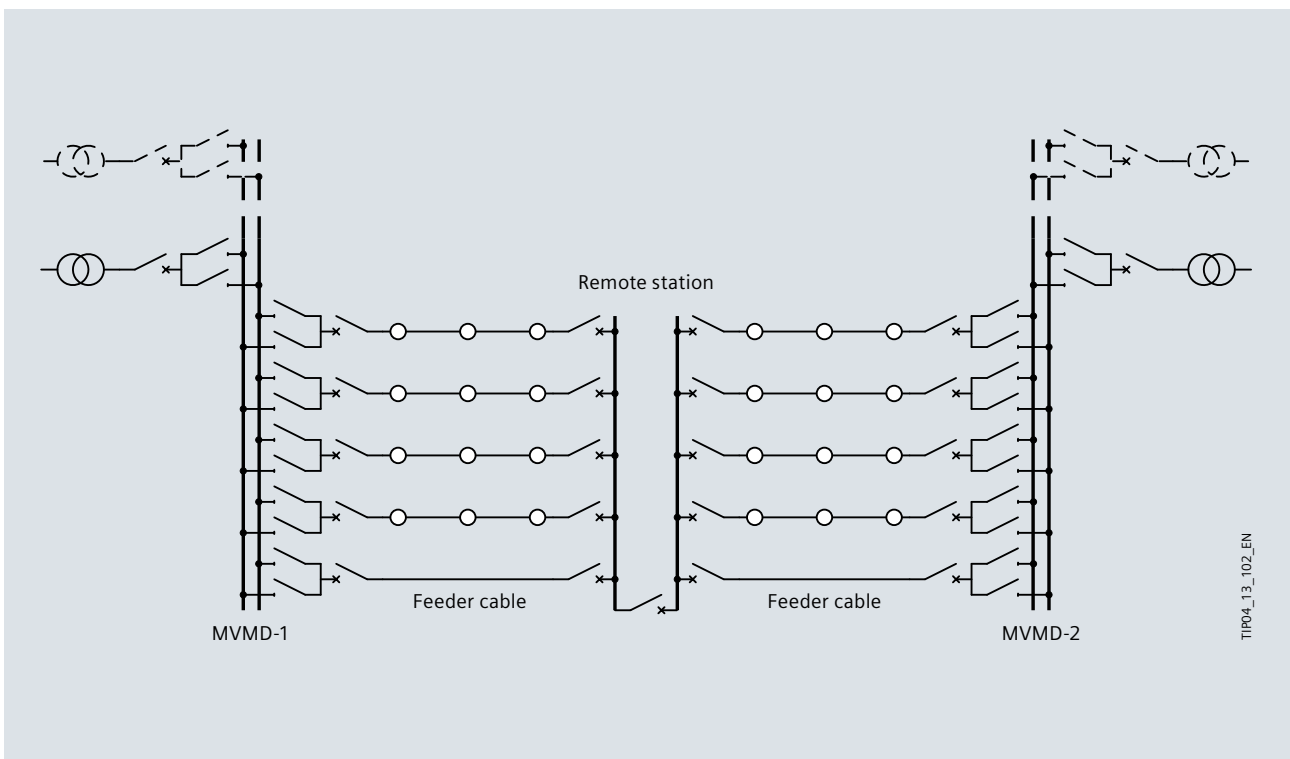

Fig. 4/6: Network configuration: coupling of two main substation areas

[back to page 48](#)

## 4.3 Configuration of the Switchgear

The configuration of the switchgear, i.e. whether a single or double busbar, or busbar couplers longitudinal (BCL) and/or busbar couplers transversal (BCT), depends on:

- Number of connected feed-in points
- Implemented network configurations
- Network mode of operation during normal operation and when a fault occurs

In all cases, it must be ensured that each busbar section can be isolated and galvanically separated subnetworks can be operated. The configuration of a busbar in a main substation can usually be divided according to the connected system configuration.

### Spurs

If the distribution transformers are connected directly in the spur, then a single busbar is sufficient for the switchgear from which the spurs are routed. This switchgear is usually a subordinate main feed-in point, i.e. not a transformer substation. Sectionalizing is recommended if a large number of transformers is to be connected. Feed-in from the upstream network as a ring or double spur should then be connected separately to both halves of the busbar.

### Double spurs

Double spurs are used to supply subordinate switchgear from a main substation or main feed-in point. A single busbar with sectionalizing is sufficient to ensure the supply. To increase the supply reliability, the busbar sections can be separated spatially.

### Rings

If the medium-voltage grid is configured exclusively with rings, a single busbar with BCL is sufficient. The rings start on one side of the coupler and ends on the other side. To increase the supply reliability, the busbar sections can be separated spatially.

### Lines

In a line network, the decision between a single or double busbar depends on the respective remote station. If the remote station is a main substation, a single busbar with BCL can also be used. However, a double busbar is usually preferred. If two (possibly three) transformers supply the double busbar in the main substation, then for reasons of flexibility, a BCL with a BCT for each block is recommended.

### Mixed network configuration (rings and lines)

As for a line network, a single busbar with BCL is also possible here if the remote station of all lines is a main substation. The rings are then connected to both sides of the BCL.

If a double busbar with BCL is used, the rings start and end on the same block, but on different busbars so that only half of the open rings fail when a fault occurs on the busbar.

The BCT is highly recommended for a single block with rings. A duplex system is also possible for this network configuration in order to save costs for the circuit-breakers in the rings.

*Note: A duplex system is a switchgear system with two single busbars installed back-to-back or opposite to one another, in which the cable feeder or respectively the feed-in panel are both connected to each busbar, each with a circuit-breaker. This also provides the function of a double busbar.*

A single busbar is sufficient for switchgear without feed-in. If it is a pure remote station, then a BCL is generally not required. However, a BCL is recommended for a larger number of lines ( $\geq 8$ ). A BCL is required for a remote station with attached rings or for a main substation.

Because of the shorter cable lengths in industrial or infrastructure projects compared to those for the supply in public networks, rings and lines can be operated with higher utilisation with regard to the voltage drop. So that it is not necessary to use double cables for rings (two cables in parallel on one circuit), it is recommended that rings are not loaded with more than 300 A, with a single-sided supply. For double spurs, a load of 500 A should not be exceeded.

## 4.4 Power System Protection Equipment

The following section considers the protection of electrical equipment and their components against faults through protection devices and systems, and particularly the assessment of their usefulness. Technical details about the configuration and functioning principle of the protection relays and the associated modules can be found in the relevant documents to be obtained from the manufacturer.

Power system protection should limit the effects of a defect in a system element on the system operation and reduce the effects on parts that are directly affected as far as possible. The criterion of selectivity, i.e. the clear identification of the power supply unit affected by the fault and its disconnection, is clearly linked to these requirements. In order to reduce the effects of a system fault as much as possible, the protection must take effect as quickly as possible. This property has the side effect that the destructive effects of high fault currents and arcs are reduced. The basic idea behind power system protection is the detection of a fault through the presence of abnormal electrical states, and then to determine which points in the network should be disconnected.

Short circuits and earth faults are the most important faults for which the protection must be provided. The following are characteristic for these faults:

- Overcurrent
- Collapse and displacement of the voltages

The protection function is based on the determination and evaluation of these variables. Overcurrent and voltage changes occur not only in the immediate vicinity of the fault location, but in wide areas of the network or throughout the entire network. It is therefore not enough to only measure these variables in order to decide whether a relay that responds to these variables should trip or not. Usually, additional selection criteria must be introduced in order to be able to decide about the regulation-compliant tripping operation. Particularly important for these additional variables are:

- Time
- Energy or current direction

The work involved in the requirement for selectivity mainly depends on the structure of the network to be protected, and is usually greater the more complicated it is structured.

### 4.4.1 Protection Devices for Power Systems

The power system protection devices must detect a short circuit in the power system as quickly as possible and perform a selective tripping operation. The network components and the loads should only be subject to short-circuit currents and voltage dips for as short a time as possible. When the switch is tripped by a protection device, either all loads should continue to be supplied (if an instantaneous or immediate reserve is available), or as few loads as possible disconnected, whereby they are immediately supplied again after the fault has been located and corrected (if there is only a changeover connection as power reserve).

The following protection devices are available for the power distribution:

- Overcurrent-time protection (e.g. Siemens 7SJ...)
- Cable differential protection (e.g. Siemens 7SD...)
- Transformer differential protection (e.g. Siemens 7UT...)
- Machine protection (e.g. Siemens 7UM...)
- Busbar differential protection (e.g. Siemens 7SS...)
- Distance protection (e.g. Siemens 7SA...)

Three current transformers for each feeder and, if required, three current transformers on the busbars as well as the circuit-breaker are required for the connection and operation of the protection devices. As, in contrast to the measuring instruments, the protection relay should only trip when a fault occurs, it is essential that it functions in the few moments that it is required. To guarantee this, the protection devices should have a live contact and trip circuit monitoring that immediately signal readiness for use or a fault to the control system. Without this equipment, a stationary test unit should be available in order to regularly check the protection relay during operation. During the test, an artificial fault is simulated to check the response of the relay. At the same time, operation should not be interrupted and therefore a trip during the test must be suppressed.

### 4.4.2 Selection of the Power System Protection and the Power System Protection Concept

One of the planner's tasks is the preparation of a power system and protection concept that matches the customer's requirements. As described previously, mainly spur, double spur, and ring networks are used in the infrastructure. Spur networks and open-type ringed networks are used when the changeover connection as power reserve is sufficient. Double spur networks and closed-type networks are better when implementing an immediate or instantaneous reserve. In addition to the definition of the power supply concept, the following is required for the protection configuration:

- Specification of the mounting location of the protection relay and the circuit-breaker on which the protection device is to take effect
- Selection of the protection relay type
- Recommendations for the selection of the transformation ratio of the transformers
- Specifications for the protection settings
- Consideration of specifications (for example technical supply conditions of the DSO) and / or provision of devices by the electrical utility company (for example, consumer substation)

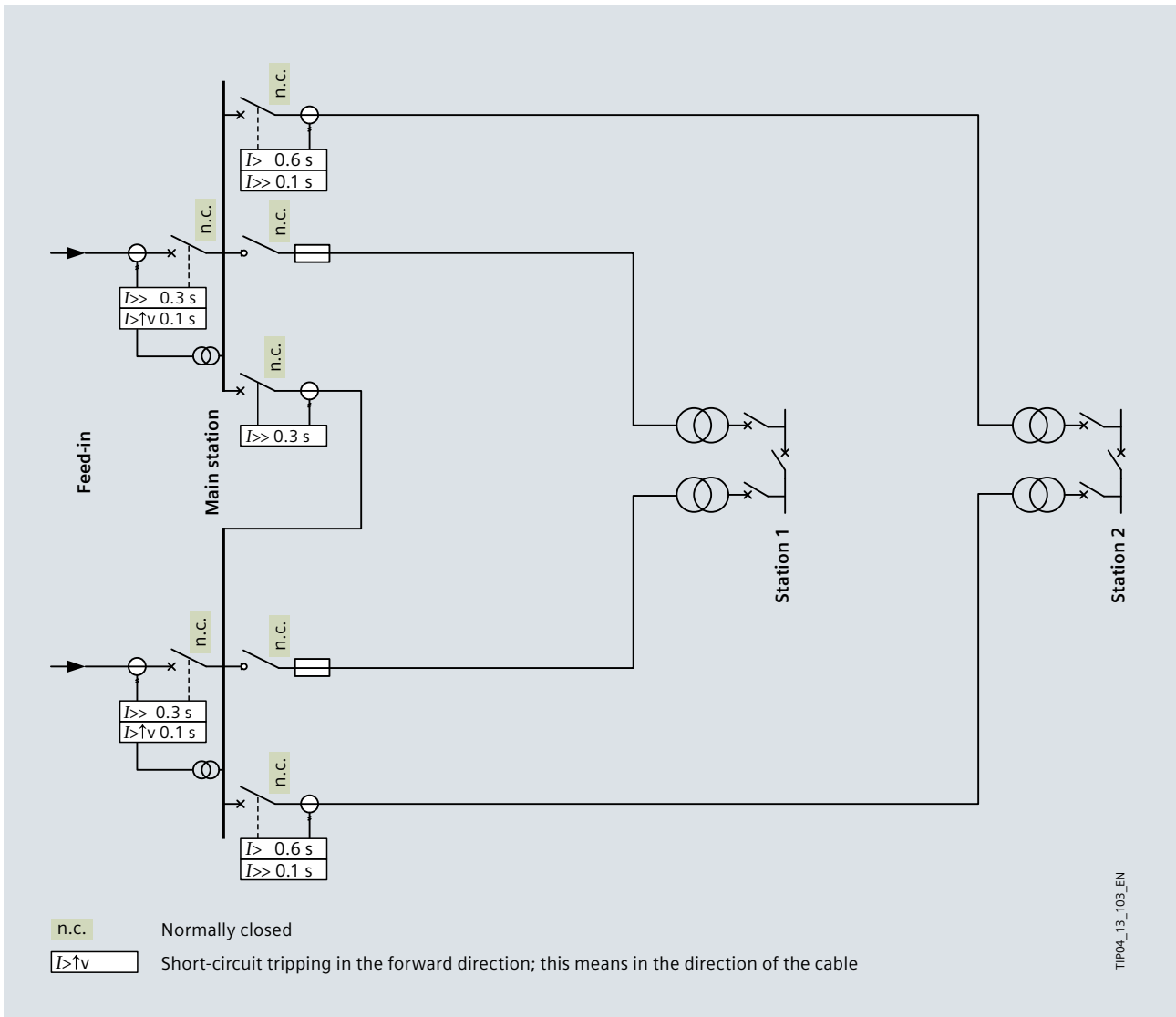

Fig. 4/7: Protection concept for a spur network

[back to page 53](#)



Various basic statements can be made for the selection of the protection devices and the time grading for the previously described standard system configurations.

*Note: The grading times specified in the following examples apply for the digital protection devices SIPROTEC 4, SIPROTEC Compact, and SIPROTEC 5 in conjunction with Siemens switchgear and correctly dimensioned current transformers.*

**Spur (see Fig. 4/7)**

The transformers connected directly in the spur are either protected with a fuse switch-disconnector combination or with the aid of an overcurrent-time protection.

**Double spur (Fig. 4/8 and Fig. 4/9)**

The subordinate switchgear is supplied from two cable systems operated in parallel. There are two ways to selectively trip a fault on one of the cable systems:

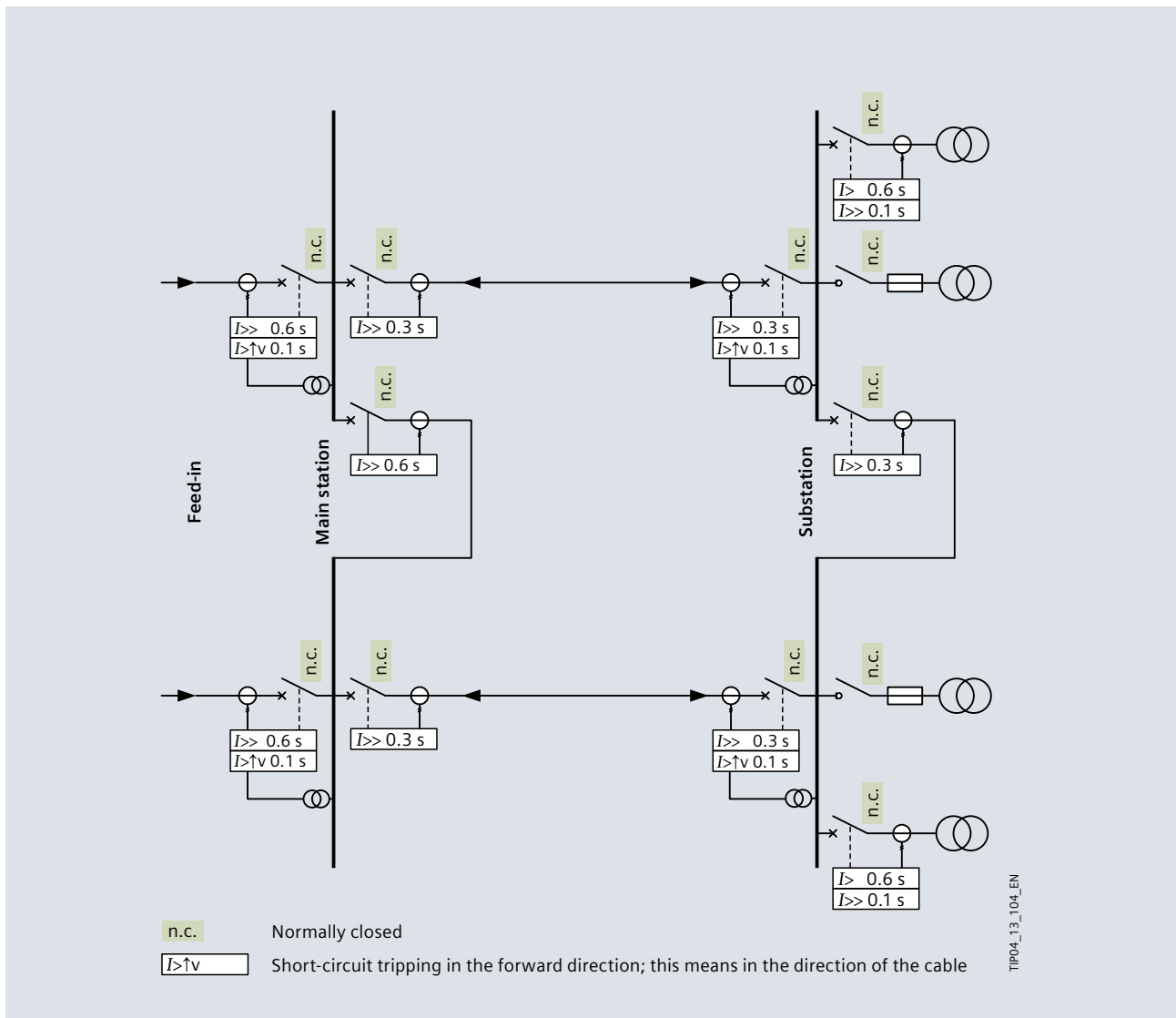

Fig. 4/8: Protection concept for a double spur with directional time-overcurrent protection

- The start and end of the cable are equipped with an overcurrent-time protection, whereby the one at the end is a directional overcurrent-time protection
- Both cable systems are protected via a cable differential protection. As a differential protection only trips faults within its protection zone, further protection must be provided for faults on the busbar of the subordinate switchgear. Usually a separate overcurrent-time protection is used in the load feeders of the double spurs or a function of the overcurrent-time protection within the differential protection

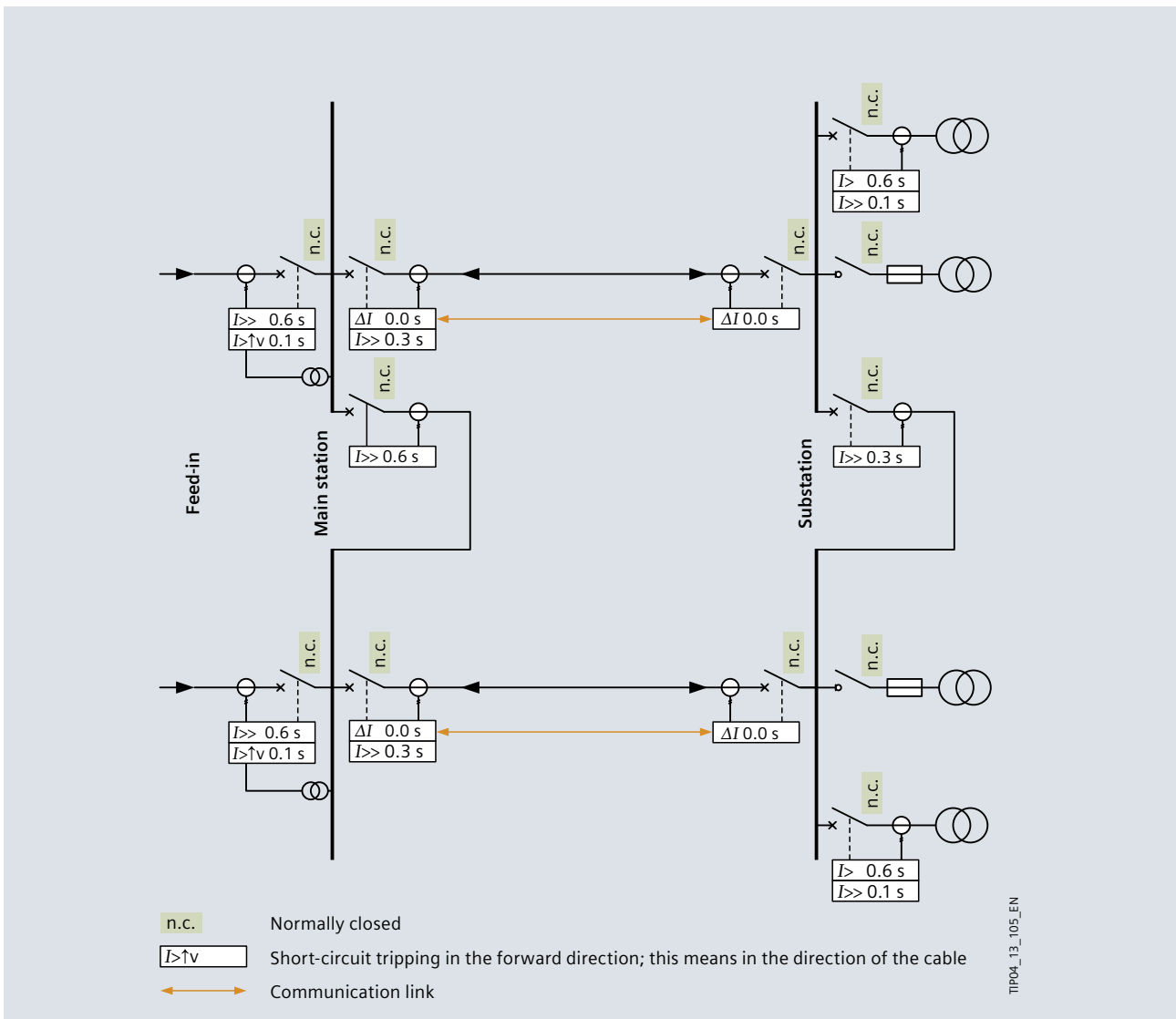

Fig. 4/9: Protection concept for a double spur with cable differential protection

[back to page 53](#)

### Open ring

Several substations are connected via a ring cable, whereby their ring-cable panels are only equipped with switch-disconnector (Fig. 4/10). The cable feeders in the main feed-in are equipped with circuit-breakers and overcurrent-time protection. The cable ring is operated openly so that when there is a cable fault only one half of the ring is shut down. The fault is usually located by means of a short-circuit indicator. After the faulty cable section was manually switched out, the disconnected substations can be connected again.

### Closed ring

Several substations are connected via a ring cable. For an immediate reserve, i.e. a cable fault is disconnected selectively without interrupting the supply of the stations, all cable panels in the station must be equipped with circuit-breakers. There are several options available for a selective protection disconnection for a cable fault.

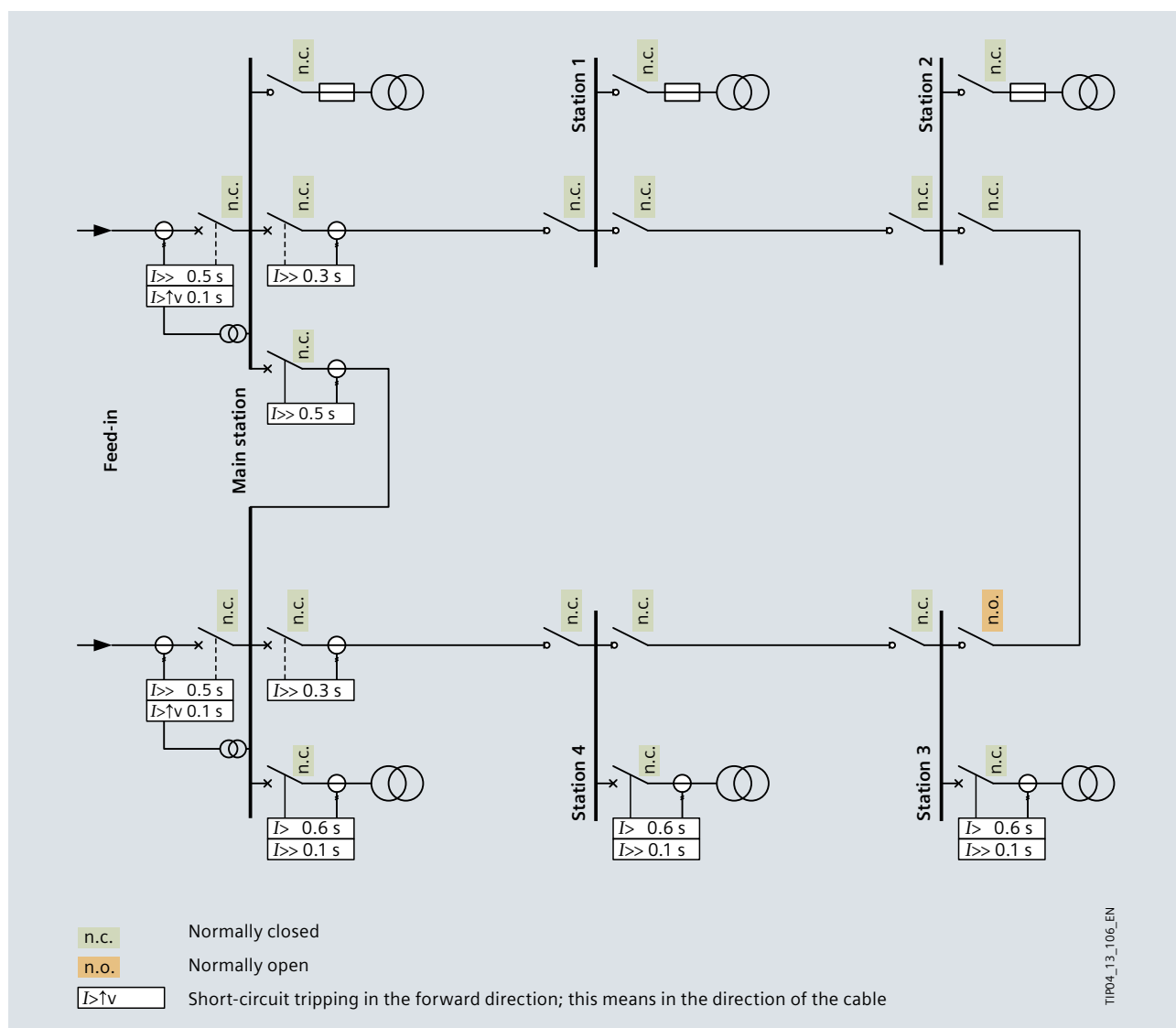

Fig. 4/10: Protection concept for a network with open rings

### Direction determination and time grading (Fig. 4/11)

The cables can be disconnected selectively with the aid of the direction determination of short-circuit currents when a fault occurs and a time grading. Voltage transformers are required for the direction determination. The direction determination is required so that fault current is only cleared when it is in the direction defined in the protection device. As can be clearly seen in Fig. 4/11, this method is only useful in the ring for a few stations (usually three at the most), as otherwise the tripping times in the main feed-in are too high. You must also consider that because of the impedance conditions when a fault occurs at the outgoing feeder of the ring in the main station, nearly the entire fault current is at first led through this panel.

The current component that flows from the opposite side does not energise the protection devices on this side. Only after the fault has been cleared on one side, enough fault current can flow from the other side so that the fault can be finally cleared. This results in the breaking times having to be added. This must be taken into account in the settings in the upstream overcurrent-time protection devices.

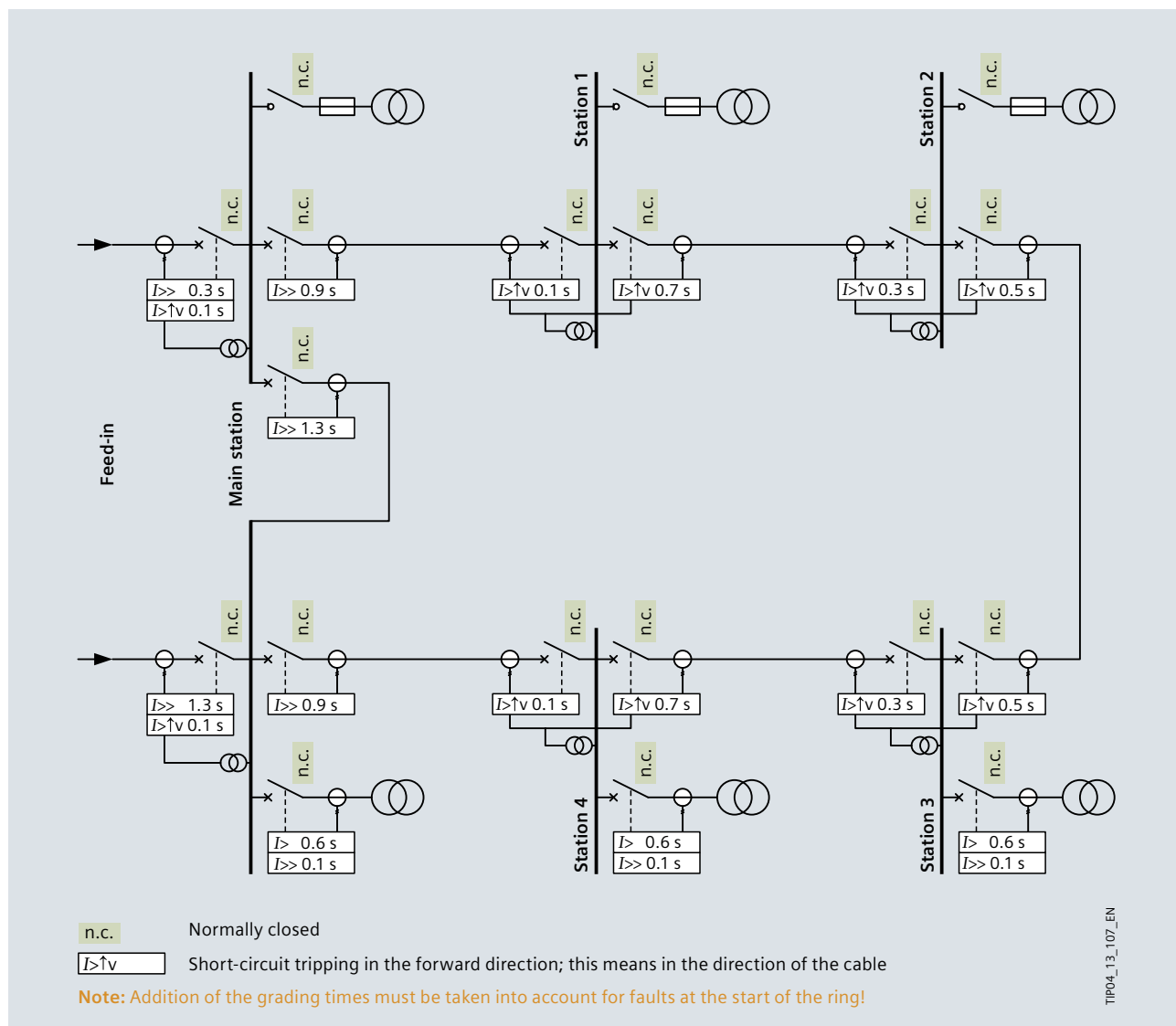

Fig. 4/11: Protection concept for a network with closed ring and time grading

### Directional comparison protection (Fig. 4/12)

In the directional comparison protection, the direction determination is extended so that no time grading is required in the ring. Through the evaluation of the fault current direction and a corresponding blocking of the protection device at the other end of the cable or the adjacent ring panel in the station, all protection devices in the ring can be set to the same delay time. The blocking can be performed via binary inputs/outputs with copper wiring as well as via a system interface with fibre-optic cable (FOC). The evaluation and blocking as well as the resetting of the breaking signal must be performed within the set time delay.

Note: With the SIPROTEC protection devices from Siemens, this is guaranteed within 100 ms even over longer distances (also within 50 ms under certain boundary conditions).

Because of the current distribution over the two ends of the ring, this can also result in an addition of the breaking times until the fault is finally cleared within the cable ring. The advantage of the same breaking times is noticeable in larger rings (more than three stations in one direction).

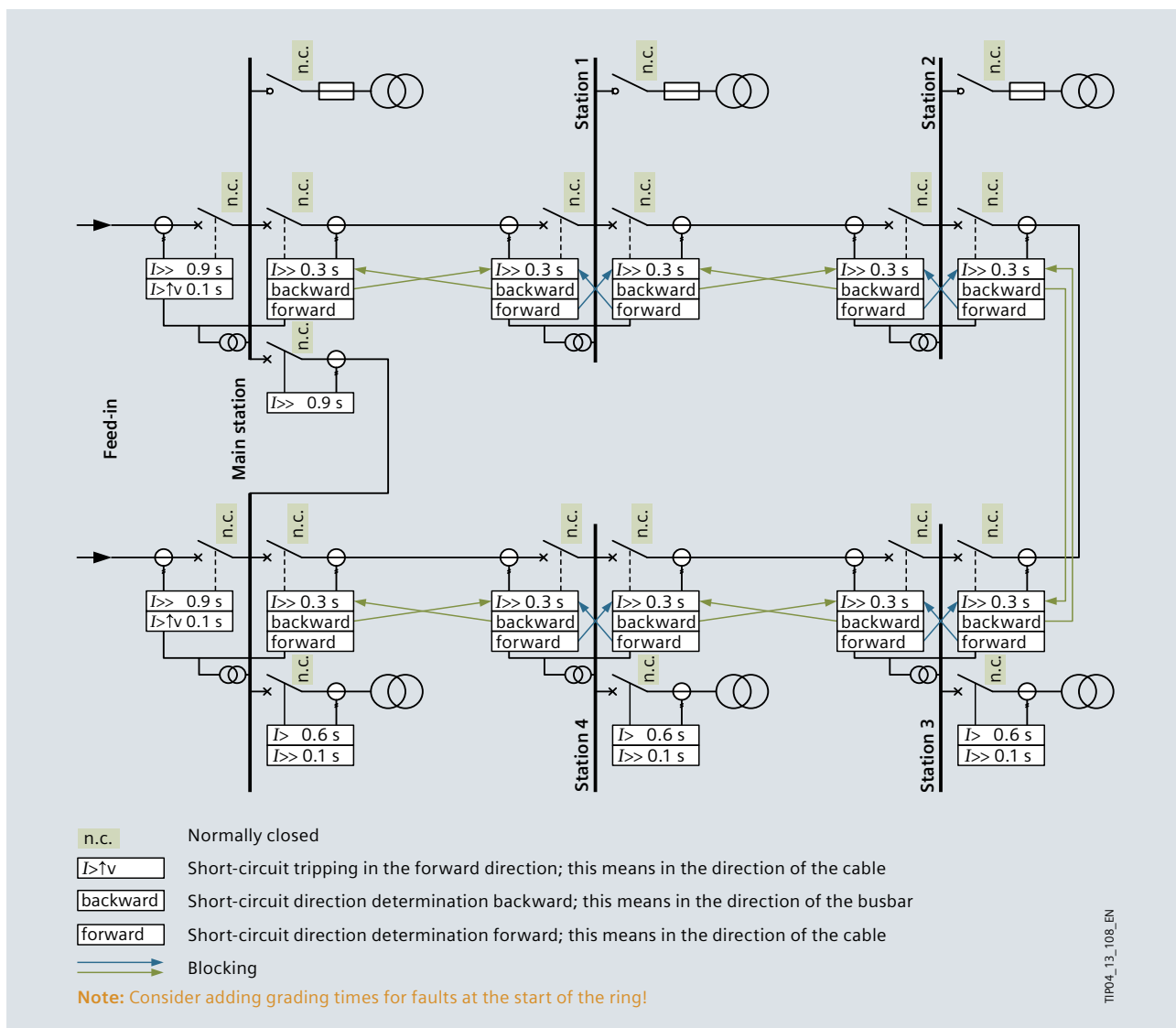

Fig. 4/12: Protection concept for a network with closed ring and directional comparison protection

### Cable differential protection (Fig. 4/13)

In cable differential protection, each ring-cable section is assigned to a differential protection zones. A fault within this zone results in a simultaneous disconnection of both ends by the cable differential protection. This also eliminates the problem of the possible addition of breaking times under unfavourable fault conditions. A fault outside the differential zone is not recognised as a fault. For this reason, an overcurrent-time protection should be available for possible faults within the stations either as a device or at least as a function within the differential protection device at both ends of the ring.

In modern devices, the communication between the device pairs for the cable differential protection is generally via FOC, but communication via copper cable is also possible. Because of the differential principle and the extremely fast communication between the devices, a tripping delay is not necessary. A further advantage of the differential protection principle is the simpler configuration compared with the complex structure for blocking by means of a direction comparison.

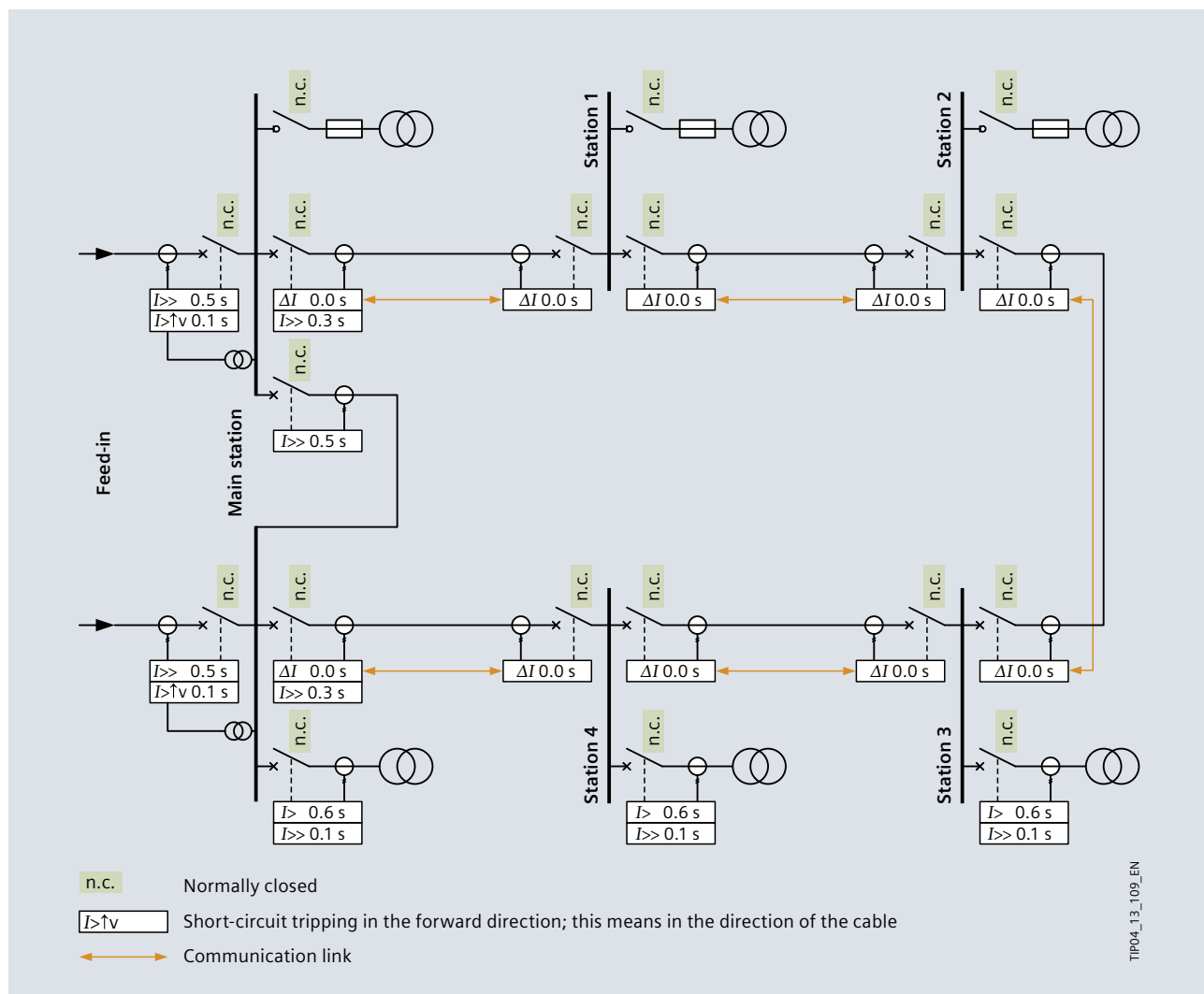

Fig. 4/13: Protection concept for a network with closed ring and cable differential protection

### Busbar protection

Busbar faults within switchgear are very improbable today because of the construction of the systems, but not impossible. Usually such faults are detected by an upstream overcurrent-time protection and cleared. However, with this method the time until disconnection depends on the grading times that result from the selective configuration of the network. In order to achieve shorter breaking times for busbar faults and therefore reduce the damage as much as possible, or to reach a higher protection level, either a special busbar differential protection can be used or a reverse interlocking through the directional overcurrent-time protection.

The busbar differential protection is the faster and more sensitive method, but entails higher costs. Fig. 4/14 shows the possibility of reverse interlocking at a substation, which is integrated in a closed ring via directional comparison protection or via cable differential protection.

In order to increase the protection level within metal-enclosed switchgear, arc-related faults that are associated with a pressure rise within the enclosed system, can be quickly detected and cleared by means of pressure switches. In such cases, the pressure switch functions as a busbar protection device.

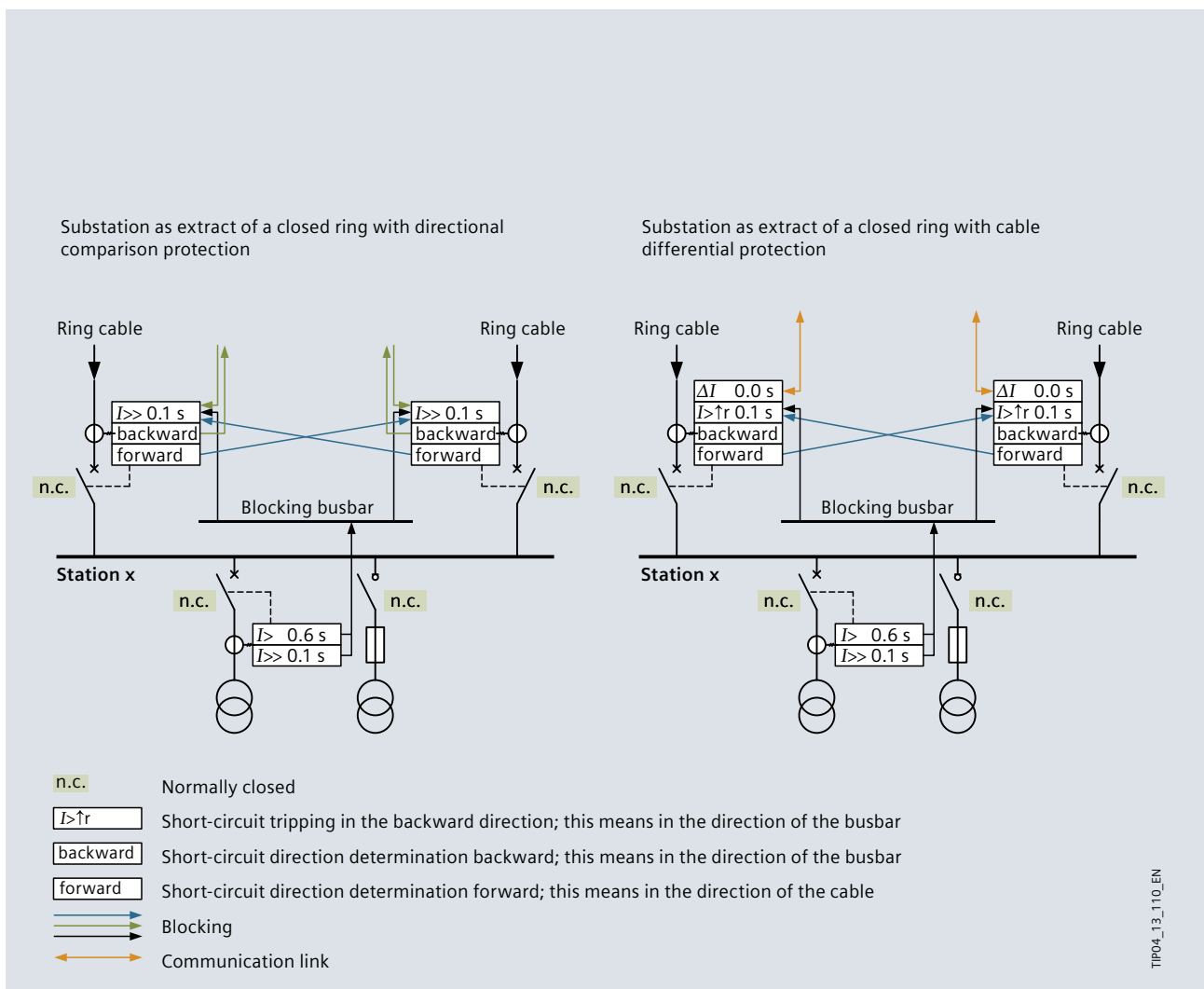

Fig. 4/14: Protection concept of the reverse interlocking as busbar protection

**Setting of the overcurrent-time protection excitation currents**

The setting of the overcurrent excitation for the protection of cable routes depends on:

- The respective operating conditions
- Current transformer transformation ratios
- Maximum operating currents that occur
- Minimum short-circuit currents that occur

Because of the release ratio (ratio of the release value to the operating value) for the relay, the operating value should not be less than 1.3 times the highest load current. The following parameters must be taken into account when setting the excitation currents:

- Maximum load current
- Carrying capacity of the connection to be protected
- Rated currents of the existing current transformer set
- Maximum and minimum short-circuit currents to be expected at the installation location of the associated transformers

The maximum load current that occurs during operation is the decisive factor for the setting of the overcurrent excitation. An excitation through overload must be excluded in all cases. Therefore a setting to more than 1.3 times the maximum load current is usual. The settings of the overcurrent-time protection or the used HV HRC fuses of the transformer outgoing feeders in the substations must also be taken into account for the selective protection grading.

## 4.5 Connection of the Neutral Point in the Medium-Voltage Cable Network

During normal operation, the connection of the neutral point has no effect on the transmission of the electrical energy. Only when a fault occurs is the connection of the neutral point to earth of importance. The neutral-point connection is not uniform in medium-voltage grids. The following neutral-point connections can be found in overhead line networks and in cable networks (Fig. 4/15):

- Operation with isolated ("free") neutral point
- Operation with earth-fault compensation
- Operation with neutral earthing, whereby a distinction can be made between low resistance and rigid neutral earthing

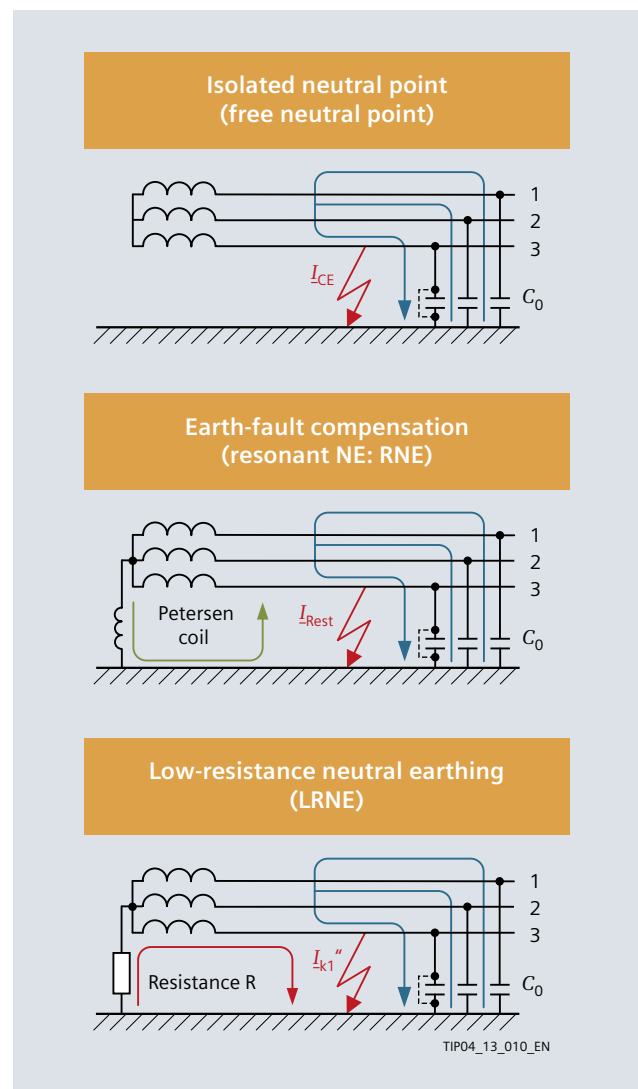

Fig. 4/15: Neutral earthing (NE) in a LV system



Depending on the neutral-point connection, there is a difference in the operating behaviour of the networks, which is described in the following sections. The following are assessed:

- Size of the single-phase short-circuit current
- Size of the neutral displacement voltage
- Transient overvoltage in the conductors not affected
- Type of voltage recovery in the affected conductors after clearing the short circuit

#### 4.5.1 Operation with Isolated Neutral Point

The most common fault in all distribution networks is the single-phase earth fault. Approximately 70 to 90% of all network faults start as a single-phase fault. In a network with a free neutral point, the conductor-earth voltages of the system are displaced when an earth fault occurs. The fault-free conductors of the network are increased to the delta voltage, whereby a voltage increase of  $\sqrt{3}$  times the normal star voltage  $U$  occurs. The earth-fault current  $I_e$  which is fed from the fault-free conductors via the earth capacitance  $C_0$ , flows across the fault location. The size of the earth-fault current is therefore determined by the earth capacitance of the conductor.

The following applies for the earth-fault current:

$$I_e = \sqrt{3} \cdot U \cdot \omega \cdot C_0$$

Only small earth-fault currents occur in spatially limited cable networks and therefore relatively small earth capacitance. The thermal effect at the fault location is small. For this reason, the cable affected by the fault can usually remain in operation until switchovers have been made in the network, which allow the cable to be isolated without affecting the loads. During the time required for the switchovers in the network, there is a danger that the earth fault develops into a short circuit, or that as a result of the increased conductor-earth voltage, a second earth fault in the network occurs on another phase conductor. Such double earth faults can affect the consumers much more than single earth faults or short circuits because two different cable connections can be affected and then two disconnections are required in the network.

In large cable networks, earth faults usually develop very quickly into short circuits. There is therefore not enough time to make the switchovers. When operating cable networks with free neutral point, it is best when the earth-fault currents are relatively small. Usually an earth-fault current range of 10 to 35 A is suitable for this operating mode. With small currents, there is a risk of intermittent earth faults with high transient overvoltages. With large currents, there can be major thermal effects through an earth-fault arc. Small industrial networks and

internal power plant networks are usually operated with an isolated neutral point. The costs for the equipment to compensate for earth-fault currents are eliminated. It is only recommended that the earth fault windings of the three voltage transformer sets that are connected openly in the delta connection are equipped with an ohmic damping resistor. This is to avoid the relaxation oscillations that can occur during the earth fault or during starting cycles. Even when the fault location is detected with the aid of earth-fault relays, which can result in the fast disconnection of the faulty line, the danger of double earth faults through earth-fault overvoltages and also the voltage increase on faulty conductors still remains.

#### 4.5.2 Operation with Earth-fault Compensation

During operation with earth-fault compensation, the feeding HV/MV transformers must have a medium-voltage winding at the neutral point for the connection of an earth-fault neutraliser. Otherwise a neutral earthing transformer must be used. When selecting the transformer to which the earth-fault neutraliser (Petersen coil) is to be connected, the relevant regulations, as described in standard IEC 60076-6 (VDE 0532-76-6), must be taken into account. The earth-fault current can also be distributed over several earth-fault neutralisers or transformer neutral points.

In a network with earth-fault compensation, the same displacement of the voltage neutral point occurs at an earth fault as in a network with free neutral point. The fault-free conductors take the delta voltage to earth. As the conductor-earth capacitances in the network are independent of the neutral point connection, the capacitive earth-fault currents also reach the same size as in a network with free neutral point.

If an earthing reactor is connected at the neutral point of a transformer, the neutral displacement voltage drives an inductive current that flows back into the network via the fault location. The capacitive earth-fault current and the inductive reactor current are in the opposite phase. If the reactor is suitably dimensioned, the two currents are approximately the same size and neutralise one another. Only the active leakage current resulting from the active components flows across the fault location. In cable networks, this current is approximately 2 to 5% of the capacitive earth-fault current. In practice, a residual reactive current resulting from inexact harmonisation and a harmonic leakage current are superimposed on the active leakage current, because the resonant circuit from network capacitances and earth-fault neutraliser are only harmonized to the basic frequency of 50 Hz.

As with the free neutral point, operation can also be maintained with earth-fault compensation when an earth fault occurs, because the conductor voltages are only displaced against the earth potential. The voltages of the conductors to one another are maintained. That is the main advantage of these two types of neutral-point connection. The supply of the consumers connected to the network is not affected by a single-phase fault and operation is also maintained during an earth fault.

Compensation of the earth-fault current is intended to automatically clear the earth-fault current and thus eliminate the fault in the network. An attempt is made to limit the fault current to the smallest possible leakage current. However, the insulation at the fault location should not be damaged after the current is cleared. This is not a problem in overhead line networks.

On the other hand for cable faults in general, automatic clearance of the current at a fault location is not always desired because the insulation is often damaged at the fault location, and this can result in earth faults or double earth faults later. Otherwise, the clearance of earth-fault currents has the same advantages for cable networks as described above.

With earth-fault compensation, the transient internal overvoltages are smaller than with the free neutral point. They reach two to three times the star voltage, whereby factors above 2.5 are relatively seldom. Arc reignition scarcely occurs. The danger of double earth faults occurring is therefore less than in networks with isolated neutral point.

The disadvantages of earth-fault current compensation are the additional costs for the reactors and the much more difficult locating of sustained earth faults compared to networks with free neutral point. Only the relatively small active leakage current can be used for a clear indication of the earth fault. Generally only electronic relays with sensitive earth-fault detection are capable of detecting these in cable networks with an active leakage current, because they are only 2 to 5% of the capacitive earth-fault current. Alternatively, transient earth-fault relays can also clearly locate an earth fault. If these are not available, however, a laborious and time-consuming search with reconnections and disconnections must be performed until the fault is localised. This method can cause significant disturbance in the network.

In medium-voltage cable networks, the common-mode reactors should be matched as closely as possible to the network capacitances. It is therefore recommended that one of the reactors be a plunge-core reactor that can be varied infinitely. The active leakage current increases the

probability of automatic clearance of the fault current. For this reason, equipment must be available for the reliable and quick detection of a cable fault.

### 4.5.3 Operation with Neutral Earthing

With neutral earthing, currents similar to short-circuit currents flow in the network when a single-phase fault occurs. They must be detected and selectively isolated as quickly as possible by the power system protection in order to clarify the situation even when a single-phase fault occurs. This eliminates the possibility of an unclear fault evaluation. The fault search is omitted, which can cause problems in the other neutral-point connection procedures.

All three phase conductors must be monitored by the protection system in medium-voltage grids with earthing of the neutral point. This means that there must be three current transformers and the power system protection must be equipped with relays effective in all three phases. In existing networks that only have two current transformers, cable-type current transformers to detect single-phase faults can be retrofitted when converting to neutral earthing. This does not have to be a cost disadvantage, because additional earth-fault relays and even transient earth-fault relays are frequently required to locate a fault in systems with free neutral point or earth-fault current compensation.

The immediate, albeit selective, disconnection of the relevant cable when a single-phase fault occurs, is frequently considered to be a major disadvantage or the neutral earthing. This argument is not generally valid, as the effect of a single-phase fault or a multi-phase fault is largely influenced by the network configuration. In a well-planned configuration of the medium-voltage cable network, an earth fault causes the selective disconnection of the relevant cable. The supply interruption can be quickly rectified through simple switchovers.

In medium-voltage grids, the direct earthing of transformer neutral points is not used. The rigid neutral earthing would result in high earth-fault currents of 10 kA or more and would have no advantages in comparison to current limiting through neutral-point resistances (low-resistance neutral earthing). Exceptions are countries that are influenced by British standardisation (BS).

The high earth-fault currents can cause major damage and potential increases at the fault location and high induction voltages in telecommunication cables. This may require costly protection measures. For this reason, the earth-fault current in medium-voltage systems is also

limited through additional neutral point impedances in countries where rigid neutral earthing is commonly used.

The permissible level for the limitation is determined by the trigger conditions for the power system protection. Even with an unfavourable network and position of the earth fault, the assigned relays must trigger reliably. In medium-voltage grids, a highest earth-fault current of 1 kA to 2 kA is practically always sufficient. This value will be in the lower range in industrial networks, because they are not as large as public distribution networks, and values down to 500 A are also common. The damage at the fault location is relatively small with such currents. However, the current is also large enough to lead to the low-resistance earth connection required to locate the fault. In pure cable networks there is therefore no reason to limit the earth-fault current further. However, in networks in which generators are connected directly, it is better when the current is limited as much as possible (stator earth fault).

The insulation stress during an earth fault is determined by the frequency of the voltage increases during operation (characterised by the earth-fault factor according to IEC 60071-1, VDE 0111-1) and by the transient earth-fault overvoltage (characterised by the overvoltage factor). Compared with operation with free neutral point or with earth-fault compensation, the low-resistance neutral earthing has definite advantages with regard to the insulation stress.

With earth faults, it is particularly important that the stressing of the network with increased voltage is significantly shorter. The overvoltages are reduced through the low-resistance neutral earthing not only for earth faults, but practically for all switching procedures.

#### 4.5.4 Comparison of Neutral Earthing via Resistance or via Reactance

The low-resistance neutral earthing can be performed either by means of resistance or reactance. In the medium-voltage grids of many countries up to 20 kV, resistance earthing dominates, because the attenuation of the transient overvoltages for earth faults and switching procedures is higher. With the reactance earthing, high overvoltages can occur particularly when clearing earth faults. The neutral earthing via reactance is only recommended [2] when the ratio of the zero-sequence reactance  $X_0$  to the positive sequence reactance  $X_1$  of the network remains less than or equal to 10 ( $X_0/X_1 \leq 10$ ). This means that the earth-fault current must be more than 25% of the 3-phase short-circuit current and therefore above the minimum value required by the power system protection.

High overvoltages are to be expected if arc reignitions of circuit-breakers occur when breaking capacitive currents. The problem does not seem important for circuit-breakers without arc reignition. Despite this, the better overvoltage behaviour of the resistance earthing is advantageous particularly for voltage changes in medium-voltage grids.

There is no uniform guideline for the measurement of neutral-point resistances or reactor coils. It is appropriate that the current measurement is determined by the largest earth-fault current that was specified for the grid, for example, to meet the requirements of the power system protection. This current is considered to be the rated short-time current. The stressing duration is generally specified between 5 and 10 s taking into account long grading times and earth faults that follow in quick succession. Frequently, the resistance or reactance of the earthing unit can be determined precisely enough by means of the network star voltage and the largest earth-fault current. For an assumed maximum earth-fault current of 2,000 A, this results, for example, in an earthing resistance of 5 to 6  $\Omega$  in a 20 kV network. It is recommended however, that the attenuation of the earth-fault current is checked through the series impedance. The earthing units are isolated in the system voltage range between 10 and 20 kV for the star voltage of the network.

#### 4.5.5 Planning of Neutral Earthing

When planning the neutral earthing for a network, a decision must first be made as to where the neutral earthing is to be performed and for what magnitude the earth fault current is to be limited. The neutral point should always be earthed in the feeding station. If there are several feed-in points, then neutral earthing must be performed at each feed-in points. Only in this way is it possible to achieve a simple and safe earth-fault disconnection, independent of the network. Generally, the conditions required for neutral earthing in substations are much more difficult to fulfill.

It is therefore of advantage for a medium-voltage supply grid when a common resistance is connected to the neutral points of the transformers or a neutral earthing transformer in the feeding station. The neutral earthing is then independent of the network. Through the selection of suitable transformers or neutral earthing transformers (small zero phase-sequence impedance), the attenuation can be minimised by the zero phase-sequence impedances of these network components. The magnitude of the largest earth-fault current is mainly determined by the effective zero phase-sequence impedance of the neutral earthing and therefore mostly by the rating of the neutral-point resistance. The series impedance – and

therefore also the fault power in the secondary-unit substation – has no great effect due to the generally used high current limiting. However, when a fault occurs in the network, the earth-fault current is significantly damped by the cable impedances. In contrast to multi-phase short circuits, fault currents can occur here that are of the same size as the rated cable currents. The main point to be investigated during the planning is whether all earth faults trip the assigned relays and the relays intended as reserve protection. The worst fault case and possibly also the worst network must be taken into consideration.

The zero phase-sequence impedance is mainly responsible for the additional attenuation of the earth-fault current, and less so the positive-sequence impedance. Whereas the positive-sequence impedance of cables is a known value, which only depends on the type and conductor cross section, the zero phase-sequence impedance is generally not a fixed value. Apart from the cable configuration it also depends on environmental influences. In addition to the metal cable sheaths, other cables laid in parallel, piping, busbars, etc. also have an effect. Any cable steel tape armour or pliable wire armour also has an effect. This reinforcement is magnetised by the currents in the conductor-earth loop (residual currents) so that the zero phase-sequence impedance also becomes dependent on the current.

Therefore, during the planning of the neutral earthing, it is recommended that measurements are made to obtain an overview of the cable zero phase-sequence impedances of the network. Furthermore, those cables should be investigated where the protection conditions are not clear, for example, extremely long cables or double cables. These measurements enable a sufficiently precise calculation of the earth-fault currents. This calculation is a decisive factor for the selection of the current limiting and the specification or the neutral point impedance.

Fig. 4/16 shows a summary of the most important electrical parameters for the various neutral-point connections.

The earth-fault currents are detected via the wiring of the protection transformer using a Holmgreen connection (see Fig. 4/17a) or by means of a cable-type current transformer (see Fig. 4/17b). The following is recommended:

- Operation with isolated neutral point
    - Use of the Holmgreen connection  
if  $I_{CE\ sec} > 0.05 I_{N2}$
    - Use of the cable-type current transformer  
if  $I_{CE\ sec} < 0.05 I_{N2}$
- $I_{CE\ sec}$  capacitive earth-fault current of the galvanically connected network in relation to the secondary side of the current transformer
- $I_{N2}$  secondary side rated transformer current
- Operation with earth-fault compensation
    - Always use the cable-type current transformer
  - Operation with low resistance neutral earthing
    - Use of the Holmgreen connection  
if  $I_{k1}'' > 0.1 I_{N1}$
    - Use of the cable-type current transformer  
if  $I_{k1}'' < 0.1 I_{N1}$
- $I_{k1}''$  single-phase earth-fault current
- $I_{N1}$  primary rated transformer current

If the direction is also to be detected, additional voltage transformers must be provided.

Neutral-point connection	Free neutral point	Earth-fault compensation	Low-resistance neutral earthing	
			With impedance	Rigid
Connection				
Objective	Continuous operation during a single-phase fault		Selective tripping of a single-phase fault	
Rating	—	$X_D \approx \frac{1}{3 \cdot \omega \cdot C_0}$	$R \approx \frac{U_{nN}}{\sqrt{3} \cdot I_{k1}''} \ll \left  \frac{1}{3 \cdot \omega \cdot C_0} \right $	—
$Z_0/Z_1$	$\left  \frac{1/(j \cdot \omega \cdot C_0)}{Z_1} \right $	Very high resistance	20 ... 100	1 ... 5
Current at the fault location	$I_{CE} \approx j \cdot \omega \cdot C_0 \cdot \sqrt{3} \cdot U_{nN}$	$I_{Rest} \approx j \cdot \omega \cdot C_0 \cdot (d + jv) \cdot \sqrt{3} \cdot U_{nN}$	$I_{k1}'' = \frac{c \cdot \sqrt{3} \cdot U_{nN}}{2 \cdot Z_1 + Z_0}$	
	$10 \text{ A} < I_{CE} \leq 35 \text{ A}$	$I_{Rest} \leq 60 \text{ A}$	$I_{k1}'' \leq 2 \text{ kA}$	$I_{k1}'' \leq 1,5 \cdot I_{k3}''$
Fault duration	< 3 h	< 3 h	< 1 s	< 1 s
Formula character	d = damping ratio; v = detuning; c = voltage coefficient			

Fig. 4/16: Electrical parameters of the various neutral-point connections

[back to page 64](#)

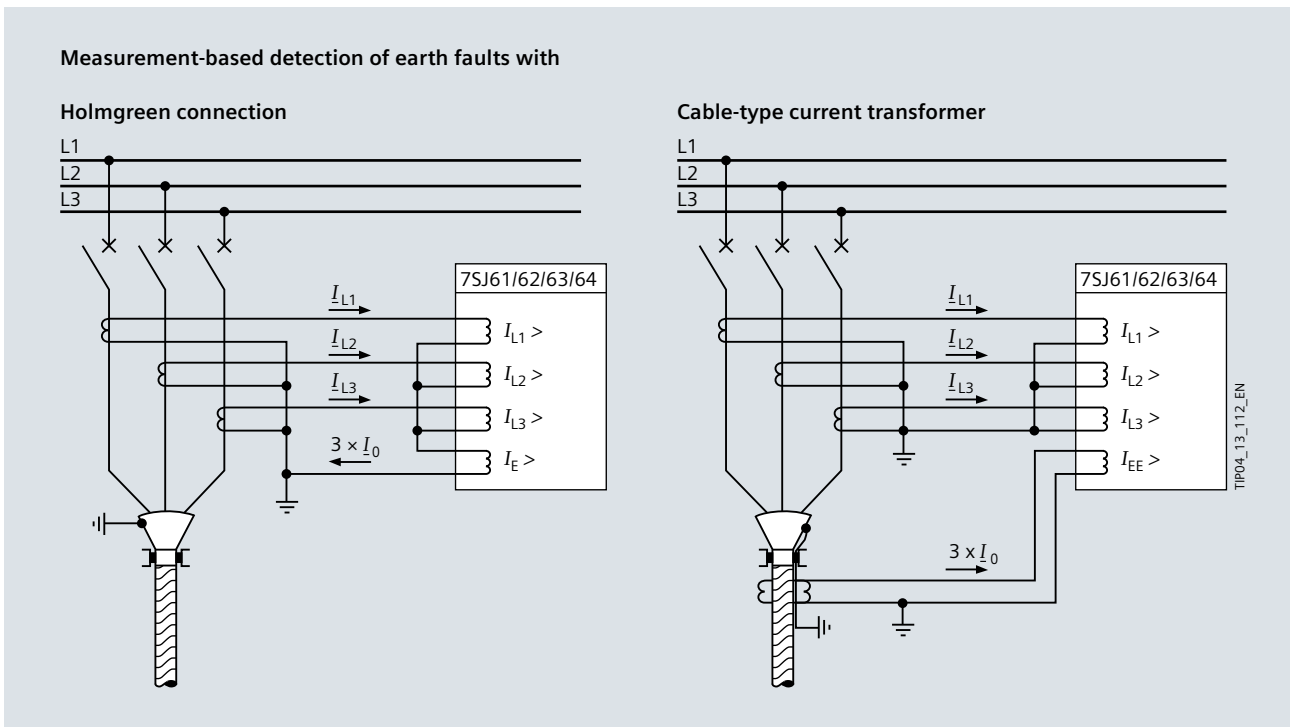

Fig. 4/17: Measurement-based detection of earth faults with a) Holmgreen connection b) cable-type current transformer

[back to page 64](#)

## 1 4.5.6 Neutral-point Connection and Transformer Vector Group

2 The neutral-point resistance or the neutral-point reactance coil can be connected to the transformer in the feeding main substation in most cases. Prerequisite is that its zero phase-sequence impedance is sufficiently small.

3  
4 With transformers, the size of the zero phase-sequence impedance depends on the connection method. Transformers in star-delta connection have zero phase-sequence impedance that corresponds to approximately 0.8 to 1 times the positive-sequence impedance. Whereas star-zigzag transformers have a relatively small zero phase-sequence impedance. It is only approximately one tenth of the positive-sequence impedance. With star-star transformers with delta stabilising winding for a third of the output, zero phase-sequence impedance can be up to 2.4 times larger than the positive-sequence impedance related to the rated power.

5  
6  
7  
8 Three-leg core transformers in star-star connection without stabilising winding have a zero phase-sequence impedance of approximately five to ten times the positive-sequence impedance. Because of the considerable stray current running through the tank walls and the associated heating, they cannot readily be used for the system earthing.

9  
10 With shell-type transformers and three separate single-phase transformers in star-star connection, the zero phase-sequence impedance is approximately the size of the open-circuit impedance due to the free magnetic return. They are therefore not suitable for system earthing. Transformers in star-delta connection and transformers in star-star connection with a tertiary delta winding are suitable for connection of earthing reactors and also for the connection of low resistances.

11  
12  
13 If earth-fault current compensation or neutral earthing is used, transformers are required on which the connection to the neutral point of the winding is possible and permissible. If this is not the case, so-called neutral earthing transformers can be used. These are three-phase reactors with zigzag connection that have a large open-circuit impedance, but a small zero phase-sequence impedance. A neutral earthing transformer can also be dimensioned with increased zero-sequence reactance to limit the earth-fault current. The installation and connection of an earthing resistance is then no longer required as the neutral earthing transformer can be earthed directly. In medium-voltage grids, the neutral earthing transformer can also be equipped with a secondary winding and therefore can also serve as a network transformer.

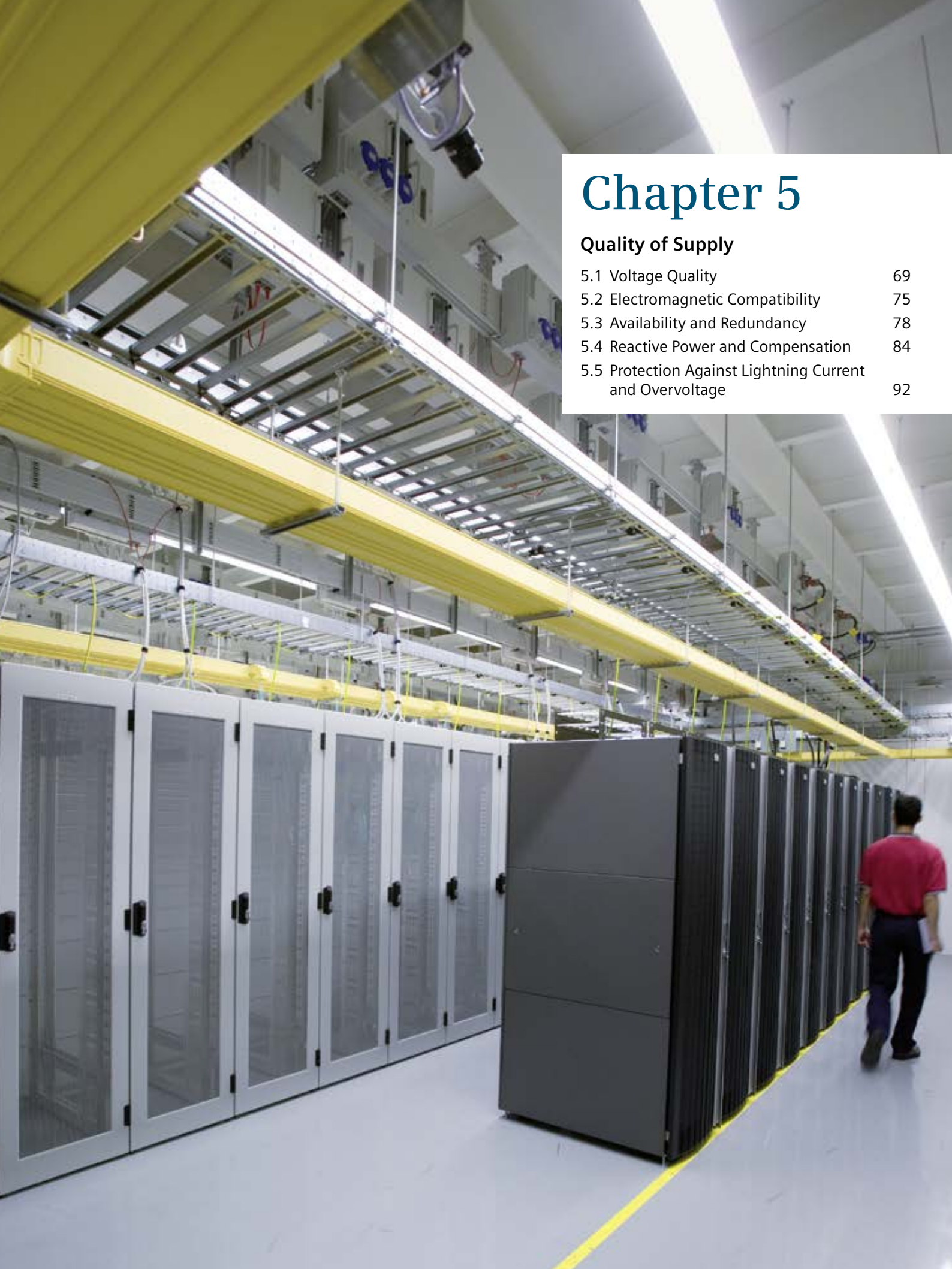

# Chapter 5

## Quality of Supply

5.1 Voltage Quality	69
5.2 Electromagnetic Compatibility	75
5.3 Availability and Redundancy	78
5.4 Reactive Power and Compensation	84
5.5 Protection Against Lightning Current and Overvoltage	92

# 5 Quality of Supply

- 1
- 2
- 3
- 4
- 5
- 6
- 7
- 8
- 9
- 10
- 11
- 12
- 13
- 14
- 15
- 16
- 17

All in all, the quality of electrical power supply is characterised by the voltage and service quality as well as its availability. The basic challenge in planning is to find the optimum of investment and operating costs on the one hand and a risk estimation (frequency and effects of failures) on the other hand (see Fig. 5/1).

Supply quality =  
voltage quality + availability + service quality

The plus sign symbolizes the linkage of the individual factors. Voltage quality does not mean pure line voltage quality in the narrow sense but also includes power quality, reactive power, and failures caused by power consuming equipment. In the planning process, the question of how supply quality is desired inevitably leads to a cost analysis. Investments made for risk minimisation must be compared to and assessed with the consequential costs from operational downtimes possibly resulting from the crash of a server, machine control, or medical facility.

A cost estimate of supply problems should at least take into account the costs of interruptions, failures, and putting the hardware into service again. Indirect costs such as costs incurred due to a deterioration of customer loyalties or even contract losses can practically not be assessed as cost factors during the planning stages. The specific usage of the facility plays an important part in a cost estimate so that the desired degree of operational flexibility should be considered as early as in the planning stages. For this, the operator has to define the later user options.

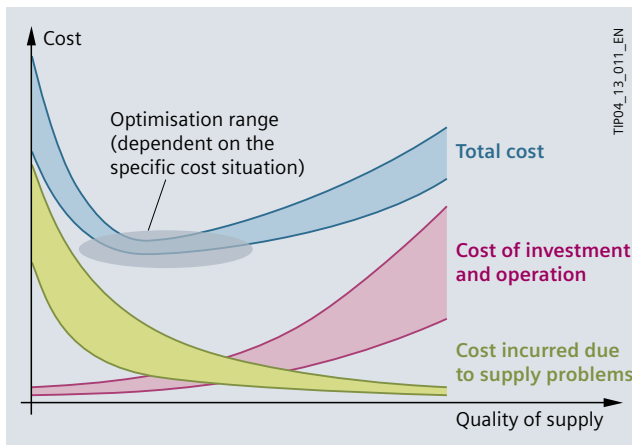

Fig. 5/1: Diagram of cost optimisation conditional upon supply quality

The electrical designer will indirectly factor in the aspect of service quality by considering the functionality and quality aspects of the products and systems involved in the project.

In order to specify the required product quality of connected power consumers with regard to their supply voltage, the curve of the "Information Technology Industry Council" (ITIC), formerly "Computer and Business Equipment Manufacturers Association" (CBEMA), as shown in Fig. 5/2 is often used. In this context it must be noted that the data is based on a manufacturer agreement concerning power supply units for computers and 120 V/60 Hz power supplies. Within the scope of the standards issued by the American National Standards Institute (ANSI), this curve is based on the IEEE 446 standard. The ITIC curve is shown in Annex B of the IEC 61000-2-4 (VDE 0839-2-4) standard. However, special emphasis is laid on the 120 V single-phase network and the limitation to IT facilities.

Today, many single-phase power supply units are used for the wide input voltage range of 110 to 240 V. As such, the curves nevertheless provide a good starting point for the protection measures to be chosen. The parameters of voltage quality and availability will be discussed in the next two sections and rounded off by an estimate of the power demand. Basically, the entire infrastructure chain must be included in such a consideration.

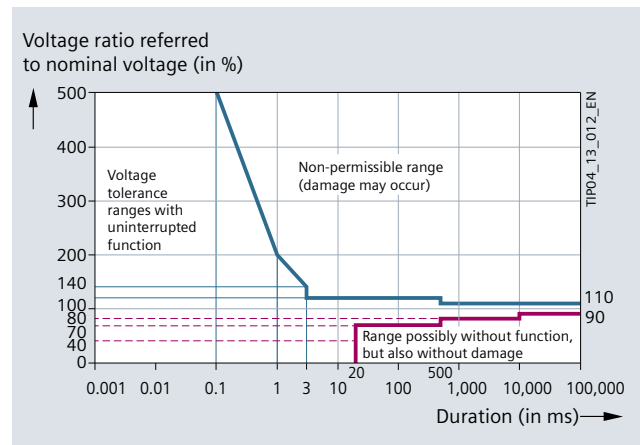

Fig. 5/2: ITIC curve for computer power supply units [4]



## 5.1 Voltage Quality

The voltage quality results from the technical specifications linked with the different interests of consumers and suppliers. It is impaired by faults in the power supply on the one hand and system perturbations caused by the connected appliances, plants, and equipment on the other hand. EN 50160 describes the following main characteristics of the supply voltage for connection to the public grids:

- Voltage magnitude, slow voltage changes
- Fast voltage changes, flicker
- Voltage dips
- Supply interruptions
- Voltage unbalance
- Harmonic voltage and interharmonic component
- Line-frequency and transient overvoltages
- Frequency variations

In many European countries, this standard serves as a guideline or reference for parameter adaptation to the characteristics of national power systems in order to create national standards. The establishment of such standards is normally performed on the basis of the experience gained by local initiatives with the implementation of monitoring systems for power quality which allow the determination of appropriate voltage parameters. Tab. 5/1 shows a more detailed subdivision with appropriate level and guidance values.

The fault parameters described in EN 50160 affect the operation of the power supply system and the connected power consumers. Tab. 5/2 assigns potential causes and effects to the individual voltage problems. Due to the current energy policy, this issue is now increasingly becoming the focus of the planner's attention. The power generation concept based on controlled power stations in the vicinity of load centres is being restructured towards decentralised power supply dependent on time and local conditions. Consequently, intelligent concepts such as the smart grid are used and that the efficient use of measuring and automation technology, storage technologies, energy consumption controls, and energy conversion technologies such as uninterruptible power supply systems and charging stations for electric vehicles need to be planned.

EN 50160 does not specify any values for electromagnetic compatibility (EMC) or limit values for the emission of interferences. It describes the characteristics of the supply voltage and related requirements for general operation. Whereas the D-A-CH-CZ guideline [5] defines EMC as the capacity of an electrical appliance to function in a satisfactory manner in the given electromagnetic environment without causing impermissible electromagnetic disturbances itself. This kind of reciprocal impact in the distribution network and on the distribution network is called system perturbation.

Characteristic	Requirements	Measurement interval	Period under consideration
System frequency	Interconnected grid: 50 Hz + 4% / -6% continuously; 50 Hz ± 1% during ≥ 99.5% of a year Isolated operation: 50 Hz + 15% / -6% continuously; 50 Hz ± 2% during ≥ 95% of a week	10 sec average	1 year 1 week
Slow voltage changes	$U_{rated} + 10\% / -15\%$ continuously $U_{rated} \pm 10\%$ during ≥ 95% of a week	10 min average	1 week
Flicker / fast voltage changes	Long-term flicker severity $P_{lt} < 1$ during ≥ 95% of a week and $\Delta U_{10ms} < 2\% U_{rated}$	2 h (flickermeter in acc. with IEC 61000-4-15)	1 week
Voltage unbalance	$U$ (negative phase-sequence system) / $U$ (positive phase-sequence system) < 2% during ≥ 95% of a week	10 min average	1 week
Harmonics $U_{n2} \dots U_{n25}$	< limit value in acc. with EN 50160 and $THD < 8\%$ during > 95% of a week	10 min average of each harmonic	1 week
Subharmonics	being discussed		1 week
Signal voltages	< standard characteristic curve = f(f) during ≥ 99% of a day	3 s average	1 day
Voltage dips	Number < 10 ... 1,000/year; there of > 50% with $t < 1$ s and $\Delta U_{10ms} < 60\% U_{rated}$	10 ms r.m.s. value $U_{10ms} = 1 \dots 90\% U_{rated}$	1 year
Short voltage interruptions	Number < 10 ... 1,000/year; there of > 70% with a duration of < 1 s	10 ms r.m.s. value $U_{10ms} \geq 1\% U_{rated}$	1 year
Long voltage interruptions	Number < 10 ... 50/year; there of > 70% with a duration of < 3 min		1 year
Temporary overvoltage (L-N)	Number < 10 ... 1,000/year; there of > 70% with a duration of < 1 s	10 ms r.m.s. value $U_{10ms} > 110\% U_{rated}$	1 year
Transient overvoltage	< 6 kV; $\mu s \dots ms$		No data

Tab. 5/1: Voltage characteristics of electricity supplied by public grids in accordance with EN 50160

Problem	Description	Cause	Effect
	<p><b>Frequency variation:</b> A frequency variation involves variation in frequency above or below the normally stable utility frequency of 50 or 60 Hz</p>	<ul style="list-style-type: none"> <li>Start-up or shutdown of very large item of consumer equipment, e.g. air conditioning equipment</li> <li>Loading and unloading of generator or small co-generation sites</li> <li>Unstable frequency power sources</li> </ul>	<ul style="list-style-type: none"> <li>Maloperation, or even damage to IT equipment</li> <li>Data loss</li> <li>System crash</li> </ul>
	<p><b>Supply interruption:</b> Planned or accidental total loss of power in a specific area; momentary interruptions lasting from half a second to 3 minutes and long-term interruptions lasting longer than 3 minutes</p>	<ul style="list-style-type: none"> <li>Switching operations attempting to isolate an electrical problem and maintain power to affected area</li> <li>Accidents, acts of nature, etc.</li> <li>Fuses, actions by a protection function, e.g. automatic recloser cycle</li> </ul>	<ul style="list-style-type: none"> <li>Sensible software process crashes</li> <li>Loss of computer/controller memory</li> <li>Hardware failure or damage</li> </ul>
	<p><b>Voltage dip/sag or swell:</b> Any short-term (half cycle to 60 seconds) decrease (sag) or increase (swell) in voltage</p>	<ul style="list-style-type: none"> <li>Start-up or shutdown of very large item of consumer equipment, e.g. air conditioning equipment</li> <li>Short circuits (faults)</li> <li>Underdimensioned power supply</li> <li>Owing to utility equipment failure or utility switching</li> </ul>	<ul style="list-style-type: none"> <li>Memory loss, data errors, shrinking display screens</li> <li>Lighting variations</li> <li>Motors stalling or stopping and decreased motor life</li> </ul>
	<p><b>Supply voltage variations:</b> Variation in the voltage level above or below the nominal voltage under normal operating conditions</p>	<ul style="list-style-type: none"> <li>The line voltage amplitude may change due to changing load situations</li> </ul>	<ul style="list-style-type: none"> <li>Equipment shutdown by tripping due to undervoltage</li> <li>Overheating and/or damage to equipment due to overvoltage</li> <li>Reduced efficiency or life of electrical equipment</li> </ul>
	<p><b>Flicker:</b> Impression of unsteadiness of visual sensation induced by a light stimulus the luminance or spectral distribution of which fluctuates with time</p>	<ul style="list-style-type: none"> <li>Intermittent loads</li> <li>Motor starting of fans and pumps</li> <li>Arc furnaces</li> <li>Welding plants</li> </ul>	<ul style="list-style-type: none"> <li>Rapid variations in the luminance of lamps causing headaches on people, disturbing their concentration; defective products caused by production shortcomings</li> </ul>
	<p><b>Transient</b> A transient is a sudden change in voltage up to several thousand volts. It may be of the impulsive or oscillatory type (also termed impulse, surge, or spike) <b>Notch:</b> This is a disturbance of opposite polarity from the waveform</p>	<ul style="list-style-type: none"> <li>Utility switching operations</li> <li>Starting and stopping heavy equipment and lifts</li> <li>Static discharge</li> <li>Strikes of lightning</li> </ul>	<ul style="list-style-type: none"> <li>Hardware damage</li> <li>Data loss</li> <li>Burning of circuit boards and power supply units</li> </ul>
	<p><b>Noise:</b> This is an unwanted electrical signal of high frequency from other equipment <b>Harmonic:</b> Distortion of the pure sine wave due to non-linear loads on the power supply network</p>	<ul style="list-style-type: none"> <li>Noise is caused by electromagnetic interference from appliances, e.g. microwave, radio, and TV broadcast signals, or improper earthing</li> <li>Harmonic distortion is affected by UPS systems, for instance</li> </ul>	<ul style="list-style-type: none"> <li>Noise interferes with sensitive electronic equipment</li> <li>Data loss</li> <li>Harmonic distortion causes motors, transformers, and wiring to overheat</li> <li>Improper operation of circuit-breakers, relays, or fuses</li> </ul>

Tab. 5/2: Main problems of power quality

[back to page 69](#)

A classification of different operational environments and the assignment of appropriate characteristic parameters and compatibility levels are described in the standard series IEC 61000 (VDE 0839). Tab. 5/3 gives an overview of the contents of the individual standards. According to IEC 61000-2-4 (VDE 0839-2-4) equipment and devices must be classified as Environment class 1 of electromagnetic compatibility when they respond very sensitively to interference parameters of power supply, such as the data

processing facilities in the data centre. Protection by UPS, filters, or surge arresters is common for this class. The classification in accordance with IEC 61000-2-4 (VDE 0839-2-4) is shown in Tab. 5/4.

Voltage stability, voltage unbalance, and harmonics play an important part in assessing malfunctions and voltage quality.

IEC 61000 – Electromagnetic compatibility (EMC)		
-2	EMC – Ambient conditions	
-2	VDE 0839-2-2	EMC – Environment – Compatibility levels for low-frequency conducted disturbances and signalling in public low-voltage power supply systems
-4	VDE 0839-2-4	EMC – Environment – Compatibility level in industrial plants for low-frequency conducted disturbances
-12	VDE 0839-2-12	EMC – Environment – Compatibility levels for low-frequency conducted disturbances and signalling in public medium-voltage power supply systems plants
-3	EMC – Limit values	
-2	VDE 0838-2	EMC – Limits – Limits for harmonic current emissions (equipment input current $\leq 16$ A per phase)
-3	VDE 0838-3	EMC – Limits – Limitation of voltage changes, voltage fluctuations and flicker in public low-voltage supply systems, for equipment with rated current $\leq 16$ A per phase and not subject to conditional connection
-11	VDE 0838-11	EMC – Limits – Limitation of voltage changes, voltage fluctuations and flicker in public low-voltage supply systems – Equipment with rated current $\leq 75$ A and subject to conditional connection
-12	VDE 0838-12	EMC – Limits – Limits for harmonic currents produced by equipment connected to public low-voltage systems with input current $> 16$ A and $\leq 75$ A per phase
-4	EMC – Testing and measuring procedures	
-7	VDE 0847-7	EMC – Testing and measurement techniques – General guide on harmonics and interharmonics measurements and instrumentation, for power supply systems and equipment connected thereto
-15	VDE 0847-15	EMC – Testing and measurement techniques – Flickermeter – Functional and design specifications
30	VDE 0847-30	EMC – Testing and measurement techniques – Power quality measurement methods

Tab. 5/3: Structure of the standard series IEC 61000 (VDE 0838, VDE 0839, VDE 0848)

<b>Class 1</b>	This class applies to protected supplies, having compatibility levels which are lower than for public grids. It refers to the operation of equipment which responds in a very sensitive manner to disturbances in the power supply, for example the electrical equipment of technical laboratories, certain automation and protection gear, certain data processing facilities etc.
<b>Class 2</b>	This class generally applies to points of common coupling (PCC) with the public grid and for in-plant points of coupling (IPC) with industrial and other non-public power supply networks. The compatibility levels for this class are generally identical with those applying to public grids. Therefore, components which were developed for use in public grids can also be employed in this class for industrial environments.
<b>Class 3</b>	This class only applies to in-plant points of coupling (IPC) in industrial environments. For some disturbances, it comprises higher compatibility levels than those in Class 2. This class should be considered, for example, if one of the following conditions is true. <ul style="list-style-type: none"> <li>• A major load share is fed by the power converters</li> <li>• Welding machines exist</li> <li>• Large motors are frequently started</li> <li>• Loads vary quickly</li> </ul>

Tab. 5/4: Electromagnetic compatibility levels in accordance with IEC 61000-2-4 (VDE 0839-2-4)

### 5.1.1 Voltage Unbalance

Unbalances arise from uneven loading of the phase conductors in a three-phase system. Since many consumers are supplied from single-phase power supply units, unbalance prevails practically at all times. However, a fine subdivision of single-phase loads in operation will usually lead to a symmetrisation. In line with the specifications of IEC 61000-2-4 (VDE 0839-2-4) for the protected supply of data centres, unbalance for stationary network operation must not exceed the permissible level of voltage unbalance  $k_{U,perm.}$  of 2% for electromagnetic Environment classes 1 and 2 and 3% for class 3, respectively.

As a rule,

$$k_U \approx S_A / S_{kV} \leq k_{U,perm.}$$

- $k_U$  Level of voltage unbalance
- $k_{U,perm.}$  Permissible level of voltage unbalance
- $S_A$  Connected load as single-phase or two-phase load
- $S_{kV}$  Short-circuit power at the linking point

### 5.1.2 Harmonics

Harmonics are overlaid oscillations deviating from the 50 Hz fundamental frequency of the power supply system with an integer multiple of the fundamental. Every periodical oscillation curve can be represented as an overlay of the sine-shaped basic curve and harmonic oscillations. Harmonics are generated by equipment with non-linear current-voltage characteristics such as transformers, gas-discharge lamps, and power electronic devices.

Important harmonic generators are:

- Power electronic devices such as converter drives, static UPS systems, rectifier systems, dimmers
- Fluorescent lamps
- Power supply units for the DC voltage supply of information and communication technology components
- Motors with non-linear current-voltage characteristics
- Converters in DC chargers
- Converters in photovoltaic systems and wind power stations

Harmonics cause, for instance:

- Heating of three-phase and alternating current motors
- Fault tripping of circuit-breakers and miniature circuit-breakers and malfunctions of ripple control receivers
- Overloading and destruction of capacitors as a result of thermal overloading
- Overheating of transformers
- Skin effects of cabling resulting in higher temperature loads and a greater voltage drop
- Malfunction of electronic devices and control units as a result of zero-crossing faults
- Problems with the compensation of earth faults
- Overloading of the N conductor

Uneven harmonics				Even harmonics	
No multiples of 3		Multiples of 3			
Order h	Relative voltage in %	Order h	Relative voltage in %	Order h	Relative voltage in %
5	6	3	5	2	2
7	5	9	1.5	4	1
11	3.5	15	0.5	6 to 24	0.5
13	3	21	0.5		
17	2				
19	1.5				
23	1.5				
25 *	1.5				

\* No values are given for  $h > 25$  since they are normally very small

Tab. 5/5: Electromagnetic compatibility levels in accordance with EN 50160 for line voltages up to 35 kV

Uneven harmonics				Even harmonics	
No multiples of 3		Multiples of 3			
Order h	Relative voltage in %	Order h	Relative voltage in %	Order h	Relative voltage in %
5	6	3	5	2	2
7	5	9	1.5	4	1
11	3.5	15	0.4	6	0.5
13	3	21	0.3	8	0.5
$17 \leq h \leq 49$	0.27	$21 \leq h \leq 45$	0.2	$10 \leq h \leq 50$	0.25

Tab. 5/6: Electromagnetic compatibility levels in accordance with IEC 61000-2-2 (VDE 0839-2-2) up to 1 kV

The compatibility levels to be observed by the distribution system operator are defined in EN 50160 (see Tab. 5/5). When connecting to the public supply grid, the user must ensure that compatibility levels in accordance with the D-A-CH-CZ guideline [5] corresponding to EN 50160 and IEC 61000-2-2 (VDE 0839-2-2) are observed at the connecting points to the public distribution grid see Tab. 5/6. Concerning the harmonic voltages of plant-internal connecting points in the non-public grids, reference can be made to IEC 61000-2-4 (VDE 0839-2-4) (see Tab. 5/7 to Tab. 5/9).

The values specified in the standards are for forming a reference level in a defined environment which exceeds the actual interference level only with a low probability (< 5%). They are used for a metrological inspection of the user's systems. Monitoring systems can be used for measuring which provide more extensive options for data processing and analysis than required by EN 50160. The SICAM Q100 Power Quality Recorder (see Fig. 5/3) is able to communicate flexibly with automation systems and evaluation stations via standard protocols such as IEC 61850 and Modbus TCP. According to IEC 61850, collected power quality data and event recordings can be transmitted to the SICAM PQS system in standard data formats such as PQDIF and COMTRADE.

SICAM Q100 meets the precision requirements of a Class A measuring device in accordance with IEC 61000-4-30 (VDE 0847-30) for measuring the voltage quality. Harmonics (see Fig. 5/4) are detected in accordance with the specifications made in IEC 61000-4-7 (VDE 0847-7) and flickers are calculated as described in IEC 61000-4-15 (VDE 0847-15).

The identification, determination, and profile formation of the measuring points for system quality monitoring play an important part in project design. Since the supply network is a dynamic system in the building infrastructure, the optimisation of the measuring points is based on the insights gained in day-to-day operation. Besides the selection of measuring points, the determination of system quality requires a definition and determination of the evaluation criteria at the individual measuring points.

In order to properly estimate harmonic voltage interferences in line with the D-A-CH-CZ guideline [5], it is important to consider the functioning principles of the harmonic generators used. According to [5], two groups are to be differentiated:

Group 1: Equipment with a low emission of harmonic content ( $10\% \leq THD_i \leq 25\%$ )

Group 2: Equipment with medium-range and high emission of harmonic content ( $THD_i > 25\%$ )

For example, pumps, ventilators, compressors, air conditioning appliances, DC-controlled fans, and compact fluorescent lamps with electronic ballast belong to Group 2. Compact fluorescent lamps with inductive ballast and 12-pulse converters are typically assigned to Group 1. For self-commutated converters with pulse width modulated conversion via power capacitors, the harmonic content is less than 10% so that such converters don't need to be considered. However, the same also applies if integrated harmonic filters for 6- or 12-pulse diode or thyristor inverters ensure a corresponding reduction.

Uneven harmonics				Even harmonics	
No multiples of 3		Multiples of 3			
Order h	Relative voltage in %	Order h	Relative voltage in %	Order h	Relative voltage in %
5	3	3	3	2	2
7	3	9	1.5	4	1
11	3	15	0.3	6	0.5
13	3	21	0.2	8	0.5
17	2			10	0.5
$17 \leq h \leq 49$	0.27	$21 \leq h \leq 45$	0.2	$10 \leq h \leq 50$	0.25

Tab. 5/7: EMC level up to 35 kV for Environment class 1 (Tab. 5/4) in accordance with IEC 61000-2-4 (VDE 0839-2-4)

Uneven harmonics				Even harmonics	
No multiples of 3		Multiples of 3			
Order h	Relative voltage in %	Order h	Relative voltage in %	Order h	Relative voltage in %
5	6	3	5	2	2
7	5	9	1.5	4	1
11	3.5	15	0.4	6	0.5
13	3	21	0.2	8	0.5
17	2			10	0.5
$17 \leq h \leq 49$	0.27	$21 \leq h \leq 45$	0,2	$10 \leq h \leq 50$	0.25

Tab. 5/8: EMC level up to 35 kV for Environment class 2 (Tab. 5/4) in accordance with IEC 61000-2-4 (VDE 0839-2-4)

Uneven harmonics				Even harmonics	
No multiples of 3		Multiples of 3			
Order h	Relative voltage in %	Order h	Relative voltage in %	Order h	Relative voltage in %
5	8	3	6	2	3
7	7	9	2.5	4	1.5
11	5	15	2	6	1
13	4.5	21	1.75	8	1
17	4			10	1
$17 \leq h \leq 49$	$4.5 \times (17/h) - 0.5$	$21 \leq h \leq 45$	1	$10 \leq h \leq 50$	1

Tab. 5/9: EMC level up to 35 kV for Environment class 3 (Tab. 5/4) in accordance with IEC 61000-2-4 (VDE 0839-2-4)

1

2

3

4

5

6

7

8

9

10

11

12

13

14

15

16

17

Finally, the load simultaneity to be expected per group must be factored in to estimate the harmonic load of the plant  $S_{OS}$  from the two group-specific shares ( $S_{Gr.1}$ ,  $S_{Gr.2}$ ) according to

$$S_{OS} = 0.5 \cdot S_{Gr.1} + S_{Gr.2}$$

The quotient  $S_{OS}/S_A$  ( $S_A$  = connected load of the plant) can be used graphically from the relation to the quotient from short-circuit power at the linking point  $S_{kV}$  and connected load of the plant (see Fig. 5/5) to assess the harmonic load content:

$$\frac{S_{OS}}{S_A} = b \cdot \sqrt{\frac{S_{kV}}{S_A}}$$

( $b = 0.082$  for low voltage or  $b = 0.058$  for medium voltage)

If the limit lines of Fig. 5/5 for  $S_{OS}/S_A$  are exceeded, passive or active filters can be used as an effective means to limit harmonic content. While passive filters influence harmonics of matched frequencies only, an active filter performs an analysis of the interference and emits a "negative" (i.e. phase-shifted by 180°) harmonic range to quench interferences as far as possible.

When an active filter is connected in parallel, the upstream line current is optimised, whereas the series connection is largely utilised for a targeted improvement of the voltage quality of individual loads. However, even active filters cannot simultaneously make current and voltage curves nearly sinusoidal.

An important use of active filters is the reduction of summed N conductor currents produced, for instance, by the phase angle control of many power supply units or energy-saving lamps. In particular, the interferences of the third harmonic with a frequency of 150 Hz add up in the N conductor. Please observe that high N conductor currents possibly require larger dimensioning of switchgear and transformers in addition to the cables, as described in VDE 0298-4. You may then consider the use of power converter transformers. Under certain conditions, the cost of oversizing transformers is balanced by reduced energy losses during operation.



Fig. 5/3: SICAM Q100 power quality recorder [back to page 73](#)

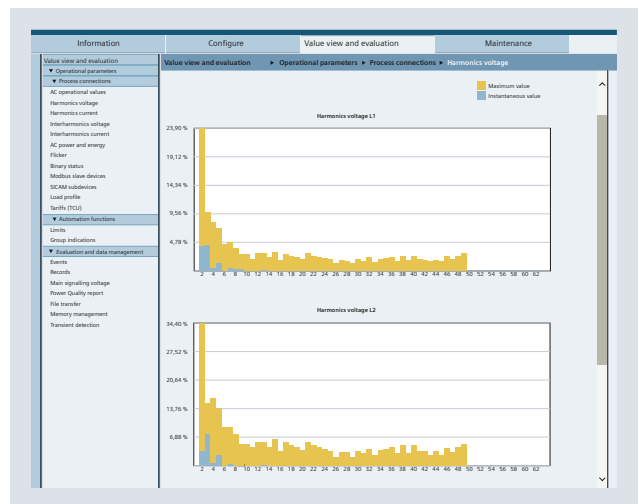

Fig. 5/4: Visualisation of harmonics with SICAM Q100 power quality recorder [back to page 73](#)

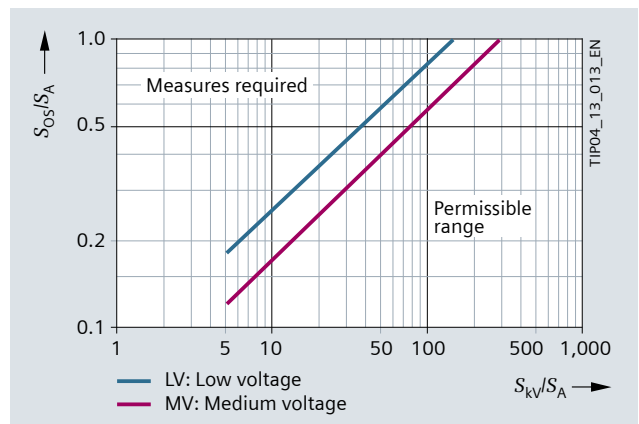

Fig. 5/5: Graphical assessment of the harmonic content

## 5.2 Electromagnetic Compatibility

The so-called EMC Directive of the European Union [6] defines electromagnetic compatibility (EMC) as "the capability of an item of equipment to work satisfactorily in its electromagnetic environment without causing electromagnetic interference itself which might be unacceptable to other equipment in the same environment".

An electric current which flows generates a magnetic and an electric field. These fields affect the environment and other equipment. Two factors play a major part in propagating the fields and thus for EMC:

- Cable routing and screening
- Power supply system

### Cable routing and screening

The propagation of interference currents and the electric and magnetic fields linked to them depend both on the cable type and their arrangement. Generally speaking and in accordance with EN 50174-2 (VDE 0800-174-2), signal and data cables should be routed well away from power supply leads.

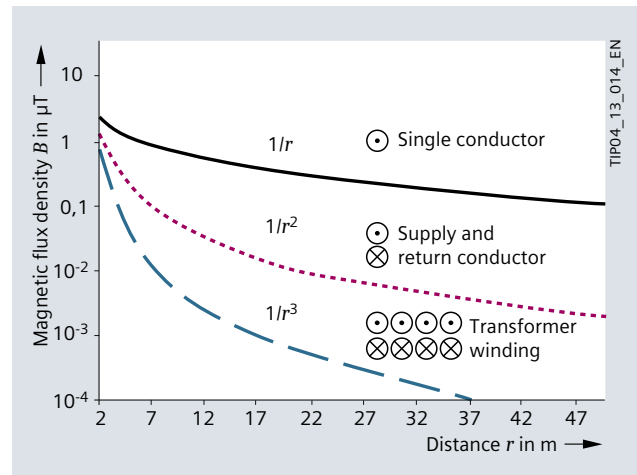

Fig. 5/6: Distance dependency of the magnetic flux density for various conductor arrangements [back to page 76](#)

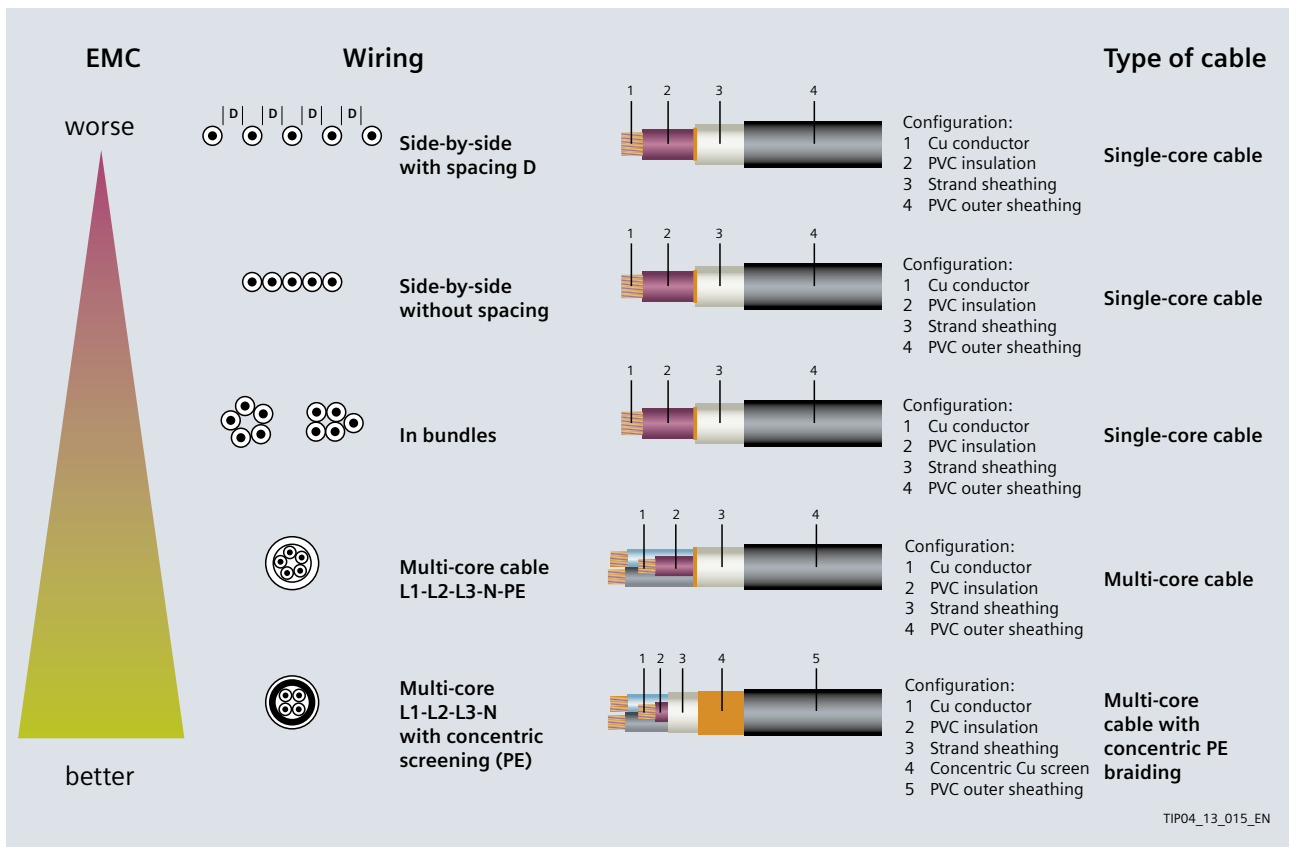

Fig. 5/7: Classification of simple cable types and wiring with regard to EMC

[back to page 76](#)

The requirements placed on this separation depend on the following:

- EMC characteristics of the IT cables
- Design, dimensions, and geometrical arrangement of the power supply cables
- Type of circuits supplied
- Possibly existing isolation devices

The procedure how to define isolation/separation requirements is described in EN 50174-2 (VDE 0800-174-2). In particular for data centres, doubling the value established for the (isolating) distance between IT cabling and power supply leads is recommended.

Bundling into cable groups and twisting phase and return conductor is beneficial for electric power supply (see Fig. 5/6). The different bundlings of conductors and the use of cable screens are arranged in an EMC-quality-significant manner in Fig. 5/7.

When comparing cables and a busbar trunking system, also the conductor splitting plays an important part. Commonly, busbar trunking systems are better in terms of EMC in case of equal currents. Fig. 5/8 also reveals that an asymmetrical

loading of conductors leads to a deterioration of EMC conditions. The symmetrical splitting of conductors in the busbar trunking system has significant advantages because of the reduced magnetic interference with the environment. The Siemens LD busbar trunking system (LDA/LDC) with its symmetrical conductor splitting is thus particularly suitable for the transmission of high currents.

### Earthing and equipotential bonding

In particular stray currents may become a severe problem. That is, currents flowing through the protection conductor and the screening of data and IT cables can cause failures, malfunctions, and even damage. In the low-voltage network, it is the connection to earth conditions in the power system which are decisive for this cable-bound EMC. The strict separation of the protection conductor from the neutral conductor in the TN-S network helps to avoid these kinds of stray currents.

For each functional unit, a central earthing point (CEP) should be additionally formed in the TN-S network. The following is to be considered in the planning phase:

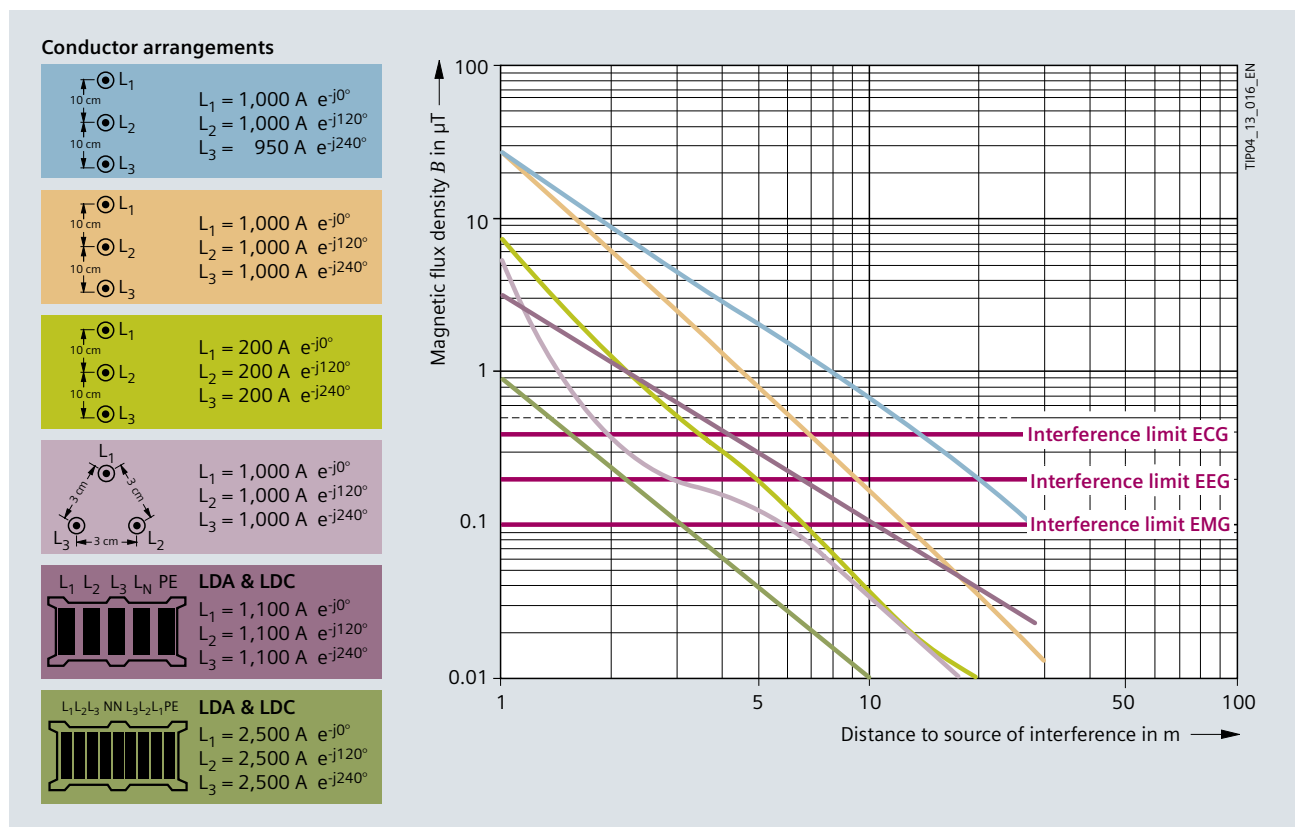

Fig. 5/8: Cable configuration and suitability with regard to EMC (the interference levels for electromyograms (EMG), electrocardiograms (ECG), and electroencephalograms (EEG) are specified in the standard IEC 60364-7-710 (VDE 0100-710))



- In the TN-S network, two earthing bridges must never be connected with each other via two conductors
- 4-pole switching devices must be used for a changeover connection in case of a supply from two networks each with its own CEP (in the Fig. 5/9 example the transformer and generator feed into separate distribution boards in a distributed layout)
- If a PEN conductor is installed, it is to be insulated over its entire course. This also applies to switchgear assemblies
- PEN and PE conductors must not be switched

The earthing concept must be thoroughly examined for UPS feed-in considerations, for example. With static UPS systems which feature different feed-ins for the rectifier input and connection of the electronic bypass, it must be kept in mind that parallel neutral conductors are to be connected in such a way that only the neutral conductor whose associated phase conductors carry currents is always connected. Please contact your TIP expert for further information.

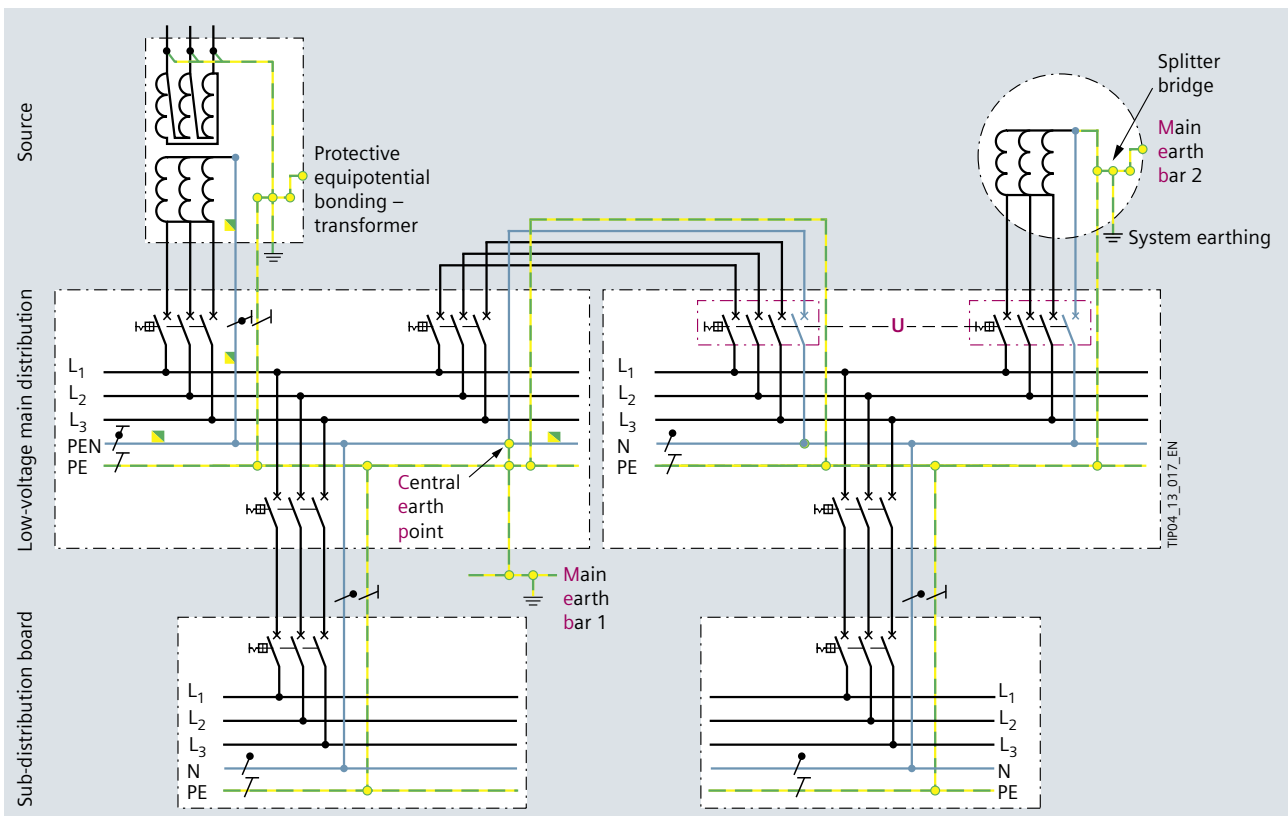

Fig. 5/9: Earthing concept for coupling distributed feed-in systems

## 5.3 Availability and Redundancy

Although there are no binding standards with regard to reliability of supply at the moment, the permissible duration of interruption and corresponding redundancy requirements should be considered in the planning phase.

Adapted to DIN 40041 (comparable to the international standard IEC 60050-191), redundancy is defined as the existence of more functional power supply components in one unit than required for maintaining this function (here: for electric power supply of the critical infrastructure components). The DIN standard explicitly notes that maintenance, i.e. monitoring, servicing, and restoring (in case of failure) proper functioning, is required for maintaining the redundancy. In particular in the field of ICT and data centre infrastructure, it is necessary that the planner intensely deals with the redundancy issue. Therefore, in the following, reference will often be made to research, experience, and studies from this field.

### 5.3.1 Availability Classes

Based on the classification performed by the Harvard Research Group (HRG) in 2002 (see Tab. 5/10), several grades of availability have established. In its High Availability Compendium [8], the German Federal Office for Information Security (Bundesamt für Sicherheit in der Informationstechnik (BSI)) presents a classification quoting downtimes corresponding to the respective status of non-availability (see Tab. 5/11).

HRG class	Designation	Explanation
AEC-0	Conventional	Function can be interrupted, data integrity is not essential.
AEC-1	Highly Reliable	Function can be interrupted, but data integrity must be ensured.
AEC-2	High Availability	Function may only be interrupted within defined times or minimally during the main operating time.
AEC-3	Fault-resilient	Function must be maintained without interruption within defined times or during the main operating time.
AEC-4	Fault-tolerant	Function must be maintained without interruption, 24/7 operation (24 hours, 7 days a week) must be ensured.
AEC-5	Disaster-tolerant	Function must be available under all circumstances.

Tab. 5/10: Availability Environment Classification (AEC) acc. to [7]

As a mathematical term, availability is defined as the quotient from the "mean time between failure" (MTBF) and the sum of all MTBF and the "mean time to repair" (MTTR):

$$\text{Availability } A = \text{MTBF} / (\text{MTBF} + \text{MTTR})$$

Availability Class (AVC)	Designation	Minimum availability	Non-availability	Downtime per month	Downtime per year
AVC 0	Standard IT system without requirements on availability	~95 %	~5 %	1 day	Several days
AVC 1	Standard safety based on basic IT protection with normal demand for availability	99 %	1 %	< 8 h	< 88 h
AVC 2	Standard safety based on basic IT protection with increased demand for availability	99.9 %	0.1 %	< 44 min	< 9 h
AVC 3	High-availability basic IT protection for specific IT resources; 100-3*	99.99 %	0.01 %	< 5 min	< 53 min
AVC 4	Highest availability	99.999 %	0.001 %	< 26 s	< 6 min
AVC 5	Disaster-tolerant	Max. availability	0	0	0

\* Supplementary risk analysis acc. to BSI-Standard 100-3

Tab. 5/11: Typical availability classes acc. to the High-availability Compendium of the BSI [8]

MTBF	MTTR	A	Operational compatibility
1 day	1 second	86,400 s / 86,401 s = 99.999 %	Not acceptable
1 month	30 seconds	2,592,000 s / 2,592,030 s = 99.999 %	Still acceptable
10 years	1 hour	87,600 h / 87,601 h = 99.999 %	User-friendly

Tab. 5/12: Availability A for different interruption characteristics

[back to page 79](#)

However, availability only becomes significant if the magnitudes of MTBF and MTTR are known. Tab. 5/12 shows three estimations of the availability in different fault scenarios.

The percentages of availability differ marginally in the sixth digit after the decimal point. The significance of a long, uninterrupted phase of operation is obvious, as many minor interruptions may impair the work rhythm. Some guidelines can be derived from this:

- Preference should be given to high quality of the products applied
- The number of components used should be kept as small as possible, since every component must be regarded as a potential source of trouble
- Repeated interference and switching operations, in particular in connection with modularisation and load-dependent operation, should be avoided
- A dependency on single components should be avoided since their failure or switching off such a "single point of failure" (SPOF) would affect the whole system

On top of this, a failure of the electrical power supply means that a restart of the infrastructure cannot be expected within seconds but more likely after many hours or even days. If a defect concerns special components such as the transformers, UPS, or switchgear panels, their replacement may take several days or weeks.

### 5.3.2 Reliability Calculations

Interruptions are mostly caused by accidental occurrences. These events can be analysed quantitatively using statistical methods and probability calculation. Therefore, probability calculation forms the basis of reliability calculation. The calculations are made with random variables which cannot be forecasted exactly, nor can the results thereof. The random variables are assessed appropriately and a large number of calculations yield results that suffice a probability with a corresponding fluctuation margin.

It should be mentioned here that though the (n-1) concept and the (n+1) concept known from redundancy considerations in network design follow the same basic idea, they proceed from a different number of "n" resources or components of the same design or function.

- (n-1) concept: "n" components are available, with "n-1" components being sufficient to ensure full functioning ("n" items available, "n-1" items are sufficient). That is, the occurrence of a fault does not yet entail a failure
- (n+1) concept: One component may fail or be removed to the extent that "n" components are sufficient for full functioning ("n+1" items available, "n" items are sufficient)

A reliability calculation can be made to quantify the reliability of supply. Using models for the replication of the system and the associated reliability characteristics, the weaknesses and optimisation options in the electrical power distribution system can be identified. The following models describing the power supply operation and failure behaviour are known:

- Element model
- Failure model
- Resupply model
- Consumer load model

The calculation of reliability characteristics is very elaborate and can be made manually for very small and simple networks only. In programs for the quantitative determination of the reliability of supply, the following methods are basically used:

- State space method
- Boolean networks
- Monte Carlo simulation

In the calculations, generally every network conditions must be considered, and for all combinations of failed network elements the frequency of occurrence and the duration of this fault state must be determined. Thus, the total failure extent can be determined for every state.

In most cases a cost analysis is used to assess the calculated characteristics. For that, the not supplied energy is determined in kilowatt hours and the interrupted power in kilowatts and converted into monetary variables. It has turned out, however, that due to the large spread of commercial and economic costs of interruptions, in most cases no clear recommendations for or against investments in network extensions can be derived.

When comparing the calculated characteristics of two extension variants, a reliability calculation may show which variant is more reliable. Since a model always has to get by with approximations and neglects, a plausibility check should be made. The calculations are made with slightly changed boundary conditions and the results are compared with regard to plausibility.

The factors determining the frequency and duration of supply interruptions include external influences, technical condition of the equipment, network planning and design, product quality, installation and commissioning, as well as operating conditions and operating modes.

## External influences

Supply interruptions can be caused by climatic and atmospheric impacts. Since these cannot be influenced directly, only their effects can be prevented or minimised by secondary measures in network planning and design as well as in network operation. Typical incidents are variations in temperature and humidity, thunderstorms, storms, ice and snow, wind-borne sand and sea salt, UV radiation, earthquake, landslide, avalanche, flood, water pollution, and aggressive gases. Also human-influenced actions and events such as sabotage, plane crash, destruction of cables during cable work, or unwanted disturbances caused by animals such as cable bite or body contact are examples of such occasions which cannot be influenced primarily.

## Technical condition of the equipment

The technical condition of the equipment available in the network affects most of all the frequency of interruptions. The age-related failure frequency of the individual pieces of equipment plays a major part in that. After the early failure period, the failure rate remains constant at a low level for a long time until the failure probability increases again from a certain age on ("bathtub curve").

To avoid investments in new equipment, it is often operated beyond its lifetime with very high repair and maintenance expenses. Intensive maintenance definitely improves the technical condition of equipment, but from a long-term perspective this can become uneconomical because maintenance work requires high personnel expenses.

Furthermore, it has to be considered that revisions require disconnection of the equipment, which also involves switchovers in the network. Every switchover in the network involves the danger of faulty circuits, which can lead to supply interruptions in parts of the network when the power system protection responds or equipment is destroyed.

## Network planning and design

Given factors such as climatic conditions, geographic structures of the supply area, as well as load and structural changes have to be considered for the network planning and design in order to achieve the intended reliability of supply. The following planning criteria must be taken into account dependent on the probabilities of occurrence and the associated effects of these external influences:

### *Redundant supply*

The reasonable interruption time is oriented towards the magnitude of the failed power affected by a supply inter-

ruption. The higher the regarded network level is (see grid level structure in chapter 2), the larger are usually the effects of a supply interruption. The expenditure for redundant supply at the individual grid levels must be selected accordingly. In medium-voltage grids, a changeover reserve is economically feasible.

### *Network configuration*

The network configuration influences the frequency of interruptions and most of all the number of consumers affected by that. For the implementation of quick resupply, the complexity of fault locating and the realization of changeover options are to be considered. Therefore, the network configuration should be simple and clear. With regard to reliability of supply, the following should be minded:

- Adaptation of the mode of operation to the supply task (see chapter 4, for example, open or closed ring)
- Avoidance of different voltage levels at one grid level
- Avoidance of multiple nodes
- Avoidance of spur lines
- Avoidance of different cable cross sections

### *Protection concept*

It is difficult to design and set protection for complex network configurations such that selective fault tripping is ensured at any time. Moreover, this requires extensive adaptations of the power system protection to changes in the network, and the probability of misadjustment (over-protection or undersized protection) increases. The danger of maloperation or misadjustments increases if a large variety of different makes and product series of protection devices is used. In this case, the product and operational know-how for the individual device types has to be acquired and kept up to date.

### *Cable laying*

For cost reasons, cables are often routed in large numbers in one single duct. For that it has to be minded that, for example, in the event of an excavator accident, all cables in the duct would be destroyed, or if a cable was destroyed by short-circuit current, the other cables would also be affected. To increase the reliability of supply, the number of cables in a cable duct should be limited. In particular redundant systems should be routed in separate ducts.

### *Short-circuit power*

High short-circuit power is required to ensure good voltage maintenance and stability of the network. However, it must not reach too high values as the equipment in the network has to be dimensioned for them and short-circuit currents

go with greater mechanical and thermal stress and higher breaking capacities.

*Automation*

The degree of automation of the network has great influence on the number and most of all the duration of supply interruptions. Even in a medium-voltage network, the automation of the central systems is advantageous with regard to the reliability of supply, despite the variety of equipment and the large amount of data. The implementation of simple network automation helps to avoid misadjustments but requires a simple and clear network configuration.

**Production, installation, and commissioning**

Supply interruptions are always attributable to the failure of single pieces of equipment. The reasons for a failure can be very different. For example, misadjustments or external influences can lead to the tripping of the protection equipment, which in turn can cause the deliberate failure of equipment (load shedding). The destruction of equipment usually leads to its failure. However, the actual failure cause might already have been implied before operation. Mistakes in the project planning phase or insufficient quality assurance during the production process may increase the probability of equipment failure. Mistakes can also be made during installation and commissioning of the equipment, which might only become apparent after a longer period of use in the network by failure of the equipment. This danger can only be averted by good technical knowledge of the installation and commissioning personnel.

The operator can minimise the risk of defective equipment by carefully selecting the manufacturing companies of the equipment used, and by influencing the proper execution of installation and commissioning works.

**Power system operation**

Productive and economic working and quick responding in the event of a failure depend on the organisation and structure of the personnel as well as on the available documents and documentation on the network.

*Documents and documentation*

Precise and always up-to-date documentation of switching states in the network, protection settings, and planning documents which show the correct position of the equipment in the network and include technical data such as cable cross sections or transmission capacities is the basis of reliable power system operation. It allows for quick proceeding in the event of a fault and thus clearly shortens

the supply interruption. For example, misadjustments are avoided in the forefront already by precise instructions in the documentation.

Failure and damage statistics can help to comprehend failure causes and processes to a certain extent and to render visible weak points or defects in the network. This allows for their early removal and an improvement of the reliability of supply.

*Personnel*

The number of personnel required for reliable operation largely depends on the size of the network, the technology used, and the degree of automation of the network. Apart from the number of personnel also its qualification, i.e. profound training, technical knowledge, and many years of work experience, plays an important part. Not to be neglected is the ability to work in a team as well as the cooperation of the personnel with external companies.

*Switching operation*

If the power system protection is set wrongly, equipment may be overloaded or destructed due to misadjustments, which leads to repair costs and an interruption of supply. Therefore, switching operation also includes setting of the power system protection.

*Procedure in the event of a fault*

The organisation of the fault-clearing service is another important factor influencing the duration of the supply interruption. Failure detection and indication depend on the degree of automation. After the failure has been detected, the fault-clearing service is responsible for the immediate evaluation of information in order to take circuitry-wise and organisational actions.

To ensure quick fault location, the required personnel must be available upon the occurrence of a fault, which can be consulted on the spot as well as on call for fault repair. Moreover, the required vehicles and/or special vehicles must be available and immediately operational.

After fault localisation, it depends on the network configuration to what extent resupply of all consumers is possible by disconnecting the fault location and switching over to other supply lines. Repair work often requires interventions on public ground, for example, blocking and breakup of roads, which can only be done with the appropriate authority's permission. The relevant authorities' contact addresses are to be kept up to date. It is even better to make agreements which allow for autonomous actions. This simplifies

the procedure because making arrangements is often not possible at the time when an intervention is required.

Fault repair might be delayed critically if the required spare parts are not available. Therefore, stockkeeping organisation is of major importance. Standardised equipment in the network is advantageous for stockkeeping. Thus, the size of the stock can be reduced considerably, which is a financial advantage and also allows for clear stockkeeping.

#### Maintenance

Maintenance combines all measures necessary to retain (service) and restore (repair) the target state. This also includes the determination and assessment of the actual state (inspection). By regularly inspecting the equipment, weak points and defects can be recognized and rectified in the course of service and repair.

### 5.3.3 Redundancy

The availability of a system is influenced by the quality of its components (the availability of the individual components) on the one hand and redundancy configurations on the other hand. Generally speaking, redundancy characterizes the use of multiple technical resources which are technically identical or at least functionally identical. In the following, the ICT terminology is used.

In order to avoid complete failure from system-related faults, so-called "diversified" systems (different technology or design for the same function) are used in a redundant manner. Electric power distribution may involve consideration being given to a very diversified range of redundancy configurations in planning.

Attention: The following differentiation of the redundancy types may easily lead to mix-ups!

#### Standby redundancy

A spare component is operated in idle mode side by side with the active component. It only becomes active should the primary component fail. This type of redundancy is also called "cold" redundancy or "hot" redundancy depending on the duration of readiness. Basically, a spare tyre is a "cold" redundancy since refitting takes quite some time. Fig. 5/10 exemplifies the output of the standby UPS being connected to the input of the static bypass line of the primary UPS.

Only when switching over to the bypass line does the standby UPS become active. In some texts, standby redundancy is also called "isolated redundancy."

#### Parallel redundancy

For a certain function of power distribution, one component more than is necessary for its maintenance is employed. To this end, the components must be operated in parallel. Since the spare component is ready immediately, we also refer to this as "hot" redundancy.

In the UPS example of Fig. 5/11, two of the three systems connected in parallel are sufficient to safely supply the connected load. In the case of maximum utilisation of redundancy, each of the connected UPS systems supplies two-third of the required power.

Generalising, we speak of an (n+1) redundancy if n items of equipment are sufficient in parallel operation to ensure undisturbed operation so that one item of equipment may fail or be switched off. Thus, no further redundancy exists then.

#### System redundancy

The configuration of two parallel supply systems allows system redundancy to be obtained. At the same time, parallelism should be maintained as far as possible down to the load be supplied. Ideally, electric power supply of consumers is ensured by at least two redundantly usable, separate power supply units.

#### Isolated-parallel redundancy

To cut back somewhat on the expenditure that would be required for system redundancy, parallel-operating components are used (n+1)-redundantly and the consumers are divided into several groups supplied in different ways. This concept, however, only brings advantages when more than two consumer groups are differentiated – that is, at least three consumer groups and three or more supply groups. Put simply, the simultaneous modularity of the systems and loads is utilised. In Fig. 5/12 a UPS redundancy with (2+1) parallel-operating UPS systems is distributed to four systems in an isolated-parallel redundancy system  $(2+1)+(2+1)+(2+1)+(2+1) = (3+1)^{(2+1)}$  for four consumer blocks. The redundancy of the four systems (3+1) is linked with the redundancy of the components (2+1).

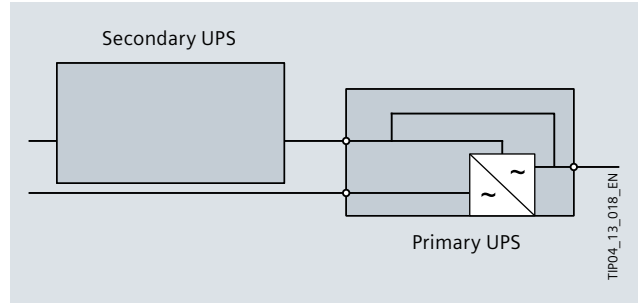

Fig. 5/10: Schematic illustration of the standby redundancy for a single UPS system [back to page 82](#)

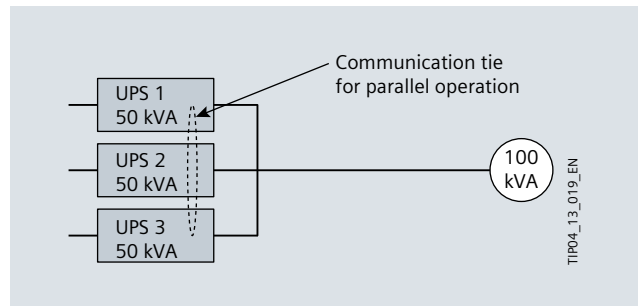

Fig. 5/11: Parallel-redundant UPS system with  $(n+1)$  equal to  $(2+1)$  [back to page 82](#)

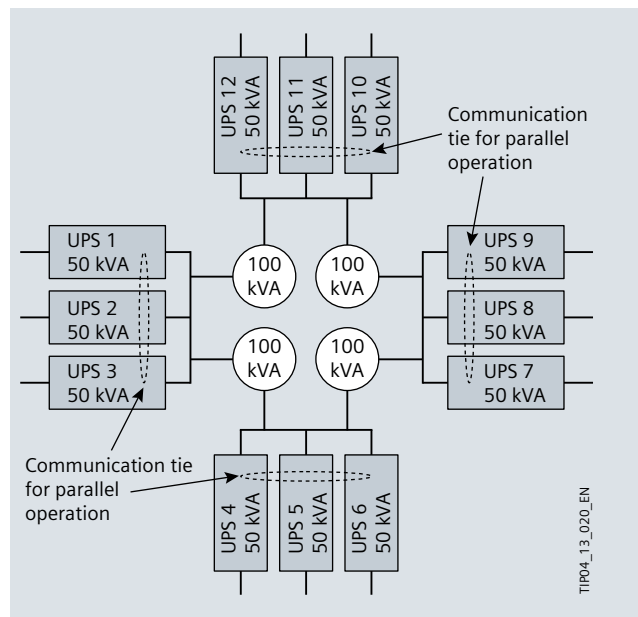

Fig. 5/12: Isolated-parallel UPS system with a link through two independent power supply units acc. to  $(m+1)^{(n+1)}$  – here:  $(3+1)^{(2+1)}$  [back to page 82](#)

## 5.4 Reactive Power and Compensation

The total power, the so-called apparent power, of a transmission network is composed of active and reactive power (Fig. 5/13). While the power consumers connected into supply transform the active power into active energy, the reactive energy pertaining to the reactive power is not consumed. The reactive power at the consumer side is merely used for building up a magnetic field, for example, for operating electric motors, pumps, or transformers.

Reactive power is generated when power is drawn from the supply network and then fed back into the network with a time delay. This way it oscillates between consumer and generator. This constitutes an additional load on the network and requires greater dimensioning in order to take up the oscillating reactive power in addition to the active power made available. As a consequence, less active power can be transported.

### Solution

With a reactive power compensation system with power capacitors directly connected to the low-voltage network and close to the power consumer, transmission facilities can be relieved as the reactive power is no longer supplied from the network but provided by the capacitors (see Fig. 5/15).

Transmission losses and energy consumption are reduced and expensive expansions become unnecessary as the same equipment can be used to transmit more active power owing to reactive power compensation.

### Determination of capacitor power

A system with the installed active power  $P$  is to be compensated from a power factor  $\cos \varphi_1$  to a power factor  $\cos \varphi_2$ . The capacitor power necessary for this compensation

is calculated as follows:

$$Q_c = P \cdot (\tan \varphi_1 - \tan \varphi_2)$$

Compensation reduces the transmitted apparent power  $S$  (see Fig. 5/15). Ohmic transmission losses decrease by the square of the currents.

### Reactive power estimate

For industrial plants that are still in a configuring stage, it can be assumed by approximation that the reactive power consumers are primarily AC induction motors working with an average power factor  $\cos \varphi \geq 0.7$ . For compensation to  $\cos \varphi = 0.9$ , a capacitor power of approximately 50% of the active power is required:

$$Q_c = 0.5 \cdot P$$

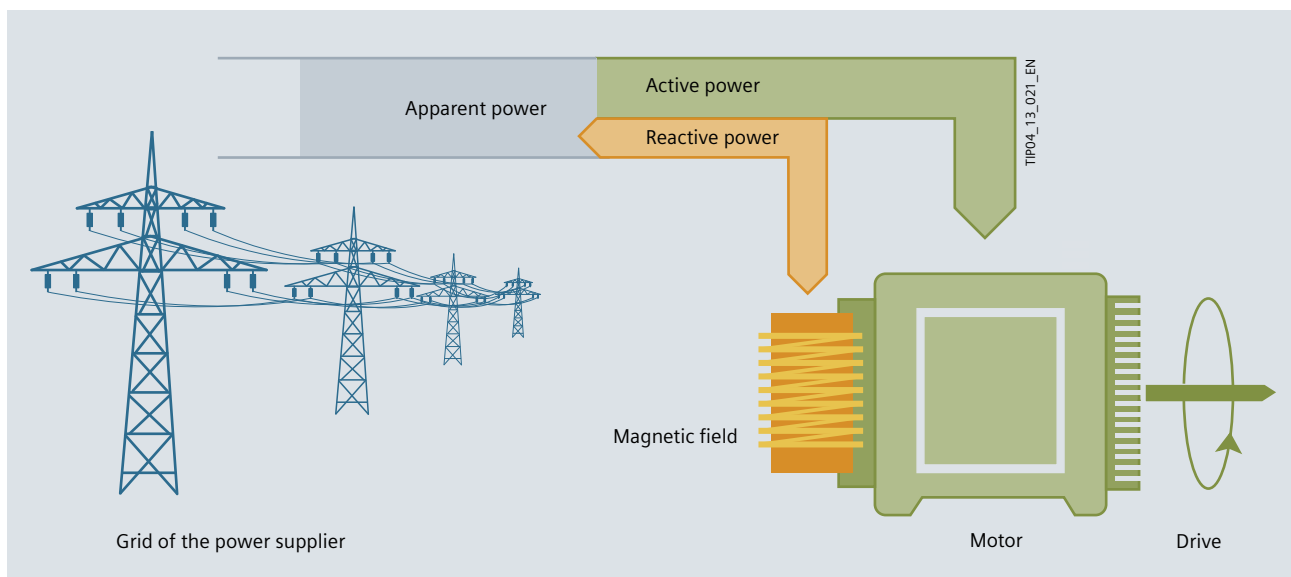

Fig. 5/13: Composition of the total power of a transmission grid



In infrastructural projects (offices, schools, etc.), the following applies:

$$Q_c = 0.1 \text{ to } 0.2 \cdot P$$

### Calculation of the reactive power based on the electricity bill

For installations which are already running, the required capacitor power can be determined by measuring. If active and reactive work meters are available, the demand of capacitor power can be taken from the monthly electricity bill.

$$\tan \varphi = \text{reactive work} / \text{active work}$$

For identical meter operating times in the measurement of reactive and active work,

$$\tan \varphi = \text{reactive power } Q / \text{active power } P$$

With

$$\tan \varphi = \frac{\sqrt{1 - \cos^2 \varphi}}{\cos \varphi}$$

the compensation power  $Q_c$  matching the active power  $P$  can be calculated for a desired value of  $\cos \varphi_2$ .

$$Q_c = Q_1 - Q_2 = P \cdot F$$

In this case

$$F = \tan \varphi_1 - \tan \varphi_2$$

To simplify the calculation of  $Q_c$ , Tab. 5/13 states the conversion factors  $F$  when a measured  $\cos \varphi_1$  is to be compensated in order to attain a power factor  $\cos \varphi_2$  in operation.

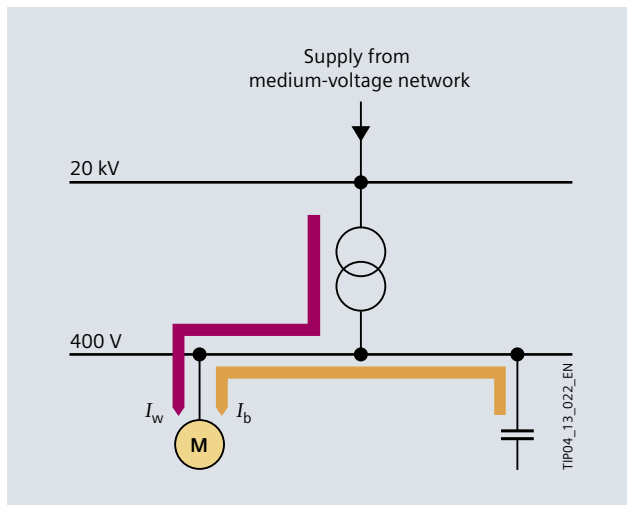

Fig. 5/14: Principle of reactive power compensation using low-voltage power capacitors [back to page 84](#)

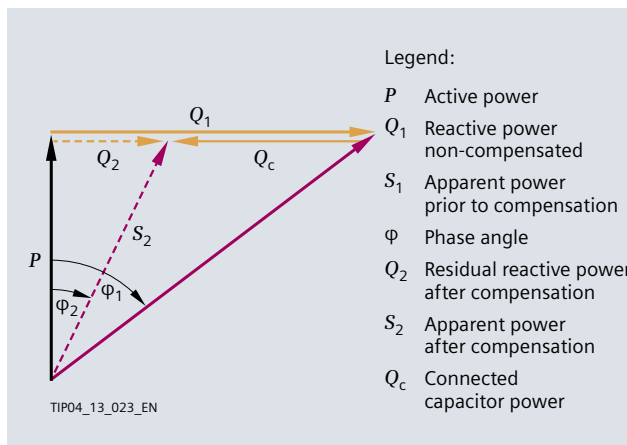

Fig. 5/15: Power diagram for a non-compensated (1) and a compensated (2) installation [back to page 84](#)

Actual value (given)		Conversion factor <i>F</i>										
$\tan \varphi_1$	$\cos \varphi_1$	$\cos \varphi_2 = 0.70$	$\cos \varphi_2 = 0.75$	$\cos \varphi_2 = 0.80$	$\cos \varphi_2 = 0.82$	$\cos \varphi_2 = 0.85$	$\cos \varphi_2 = 0.87$	$\cos \varphi_2 = 0.90$	$\cos \varphi_2 = 0.92$	$\cos \varphi_2 = 0.95$	$\cos \varphi_2 = 0.97$	$\cos \varphi_2 = 1.00$
4.90	0.20	3.88	4.02	4.15	4.20	4.28	4.33	4.41	4.47	4.57	4.65	4.90
3.87	0.25	2.85	2.99	3.12	3.17	3.25	3.31	3.39	3.45	3.54	3.62	3.87
3.18	0.30	2.16	2.30	2.43	2.48	2.56	2.61	2.70	2.75	2.85	2.93	3.18
2.68	0.35	1.66	1.79	1.93	1.98	2.06	2.11	2.19	2.25	2.35	2.43	2.68
2.29	0.40	1.27	1.41	1.54	1.59	1.67	1.72	1.81	1.87	1.96	2.04	2.29
2.16	0.42	1.14	1.28	1.41	1.46	1.54	1.59	1.68	1.74	1.83	1.91	2.16
2.04	0.44	1.02	1.16	1.29	1.34	1.42	1.47	1.56	1.62	1.71	1.79	2.04
1.93	0.46	0.91	1.05	1.18	1.23	1.31	1.36	1.45	1.50	1.60	1.68	1.93
1.83	0.48	0.81	0.95	1.08	1.13	1.21	1.26	1.34	1.40	1.50	1.58	1.83
1.73	0.50	0.71	0.85	0.98	1.03	1.11	1.17	1.25	1.31	1.40	1.48	1.73
1.64	0.52	0.62	0.76	0.89	0.94	1.02	1.08	1.16	1.22	1.31	1.39	1.64
1.56	0.54	0.54	0.68	0.81	0.86	0.94	0.99	1.07	1.13	1.23	1.31	1.56
1.48	0.56	0.46	0.60	0.73	0.78	0.86	0.91	1.00	1.05	1.15	1.23	1.48
1.40	0.58	0.38	0.52	0.65	0.71	0.78	0.84	0.92	0.98	1.08	1.15	1.40
1.33	0.60	0.31	0.45	0.58	0.64	0.71	0.77	0.85	0.91	1.00	1.08	1.33
1.27	0.62	0.25	0.38	0.52	0.57	0.65	0.70	0.78	0.84	0.94	1.01	1.27
1.20	0.64	0.18	0.32	0.45	0.50	0.58	0.63	0.72	0.77	0.87	0.95	1.20
1.14	0.66	0.12	0.26	0.39	0.44	0.52	0.57	0.65	0.71	0.81	0.89	1.14
1.08	0.68	0.06	0.20	0.33	0.38	0.46	0.51	0.59	0.65	0.75	0.83	1.08
1.02	0.70	–	0.14	0.27	0.32	0.40	0.45	0.54	0.59	0.69	0.77	1.02
0.96	0.72		0.08	0.21	0.27	0.34	0.40	0.48	0.54	0.63	0.71	0.96
0.91	0.74		0.03	0.16	0.21	0.29	0.34	0.42	0.48	0.58	0.66	0.91
0.86	0.76		–	0.11	0.16	0.24	0.29	0.37	0.43	0.53	0.60	0.86
0.80	0.78			0.05	0.10	0.18	0.24	0.32	0.38	0.47	0.55	0.80
0.75	0.80			–	0.05	0.13	0.18	0.27	0.32	0.42	0.50	0.75
0.70	0.82				–	0.08	0.13	0.21	0.27	0.37	0.45	0.70
0.65	0.84					0.03	0.08	0.16	0.22	0.32	0.40	0.65
0.59	0.86					–	0.03	0.11	0.17	0.26	0.34	0.59
0.54	0.88						–	0.06	0.11	0.21	0.29	0.54
0.48	0.90							–	0.06	0.16	0.23	0.48
0.43	0.92								–	0.10	0.18	0.43
0.36	0.94									0.03	0.11	0.36
0.29	0.96									–	0.01	0.29
0.20	0.98										–	0.20

Tab. 5/13: Conversion factors *F* for phase angle adjustments

[back to page 85](#)

### 5.4.1 Types of Compensation

Capacitors can be used for single, group, and central compensation. These types of compensation will be introduced in the following. Tab. 5/14 gives a rough overview of which compensation is suitable for certain purposes. A project-optimised mixed compensation of single, group, and central compensation is possible, too.

Together with the impedance of the upstream system, the compensation capacitors form a resonant circuit, the resonance frequency being determined by the ratio of the compensation power  $Q_C$  to the short-circuit power at the linking point  $S_{kV}$ , in line with the D-A-CH-CZ guideline [5]:

$$f_{res} = f_N \cdot \sqrt{\frac{S_{kV}}{Q_C}}$$

- $f_{res}$  Resonance frequency in Hz
- $f_N$  Line frequency in Hz
- $S_{kV}$  Short-circuit power at the linking point in kVA
- $Q_C$  Compensation power in kvar

The resonance frequency is to be considered with regard to the transmission frequencies of ripple control systems (see section 5.4.2). Resonance phenomena can be prevented or minimised with an appropriate choked compensation (see section 5.4.3).

Type of compensation	Characteristic	Applications/operational conditions	Advantages	Disadvantages
Single compensation	Compensation close to the power consumer	Large consumers with constant power demand and long ON times	Relief of consumer lines and reduction of transmission losses	Many small capacitors
		Long feeder lines to consumers (voltage drop, power reduction)	Saving of the switchgear	Higher costs
		For example, with single induction motors, welding transformers, discharge lamps		No simultaneity factor
Group compensation	Compensation in sub-distribution boards	Consumer groups (for example, motors, lamps with electronic ballast) that are very close	Relief of the consumer lines	Single interruptions may lead to overcompensation
		Concurrent ON/OFF switching of consumers and capacitors possible	Consideration of the simultaneity factor possible	Reactive current load on the consumer lines
			Reduction of the capacitor costs	
Central compensation	Compensation in main switchgear or main substations	Systems with constantly changing load and/or ON times	Improved utilisation of the capacitor power	Extra costs for control
			Further reduction of the capacitor costs	Transport of reactive power from the switchgear/station in the LV network
			General reduction of the power losses	
			Easier extendibility	
			System control possible	

Tab. 5/14: Assessment of the types of compensation

### Single compensation

In single compensation, the capacitors are directly connected to the terminals of the individual power consumers and switched on together with them via a common switching device. Here, the capacitor power must be precisely adjusted to the respective consumers. Single compensation is frequently used for induction motors (Fig. 5/16).

Single compensation is economically favourable for:

- Large individual power consumers
- Constant power demand
- Long ON times

Here, load is taken off the feeder lines to the power consumers; a continuous adjustment of the capacitor power to its reactive power demand is not possible, however.

### Group compensation

With group compensation, each compensation device is assigned to a consumer group. Such a consumer group may consist of motors or discharge lamps, for example, which are connected into supply together through a contactor or switch. In this case, special switching devices for connecting the capacitors are not required either (Fig. 5/17). Group compensation has the same advantages and disadvantages as single compensation.

### Central compensation

Reactive power control units are used for central compensation, which are directly assigned to a switchgear unit, distribution board, or sub-distribution board and centrally installed there. Control units contain switchable capacitor branch circuits and a controller which acquires the reactive power present at the feed-in location. If it deviates from the set-point, the controller switches the capacitors on or off step by step via contactors.

The capacitor power is chosen in such a way that the entire installation reaches the desired  $\cos \varphi$  (Fig. 5/18). Central compensation is recommended in case of:

- many small power consumers connected into supply
- different power demands and varying ON times of the power consumers

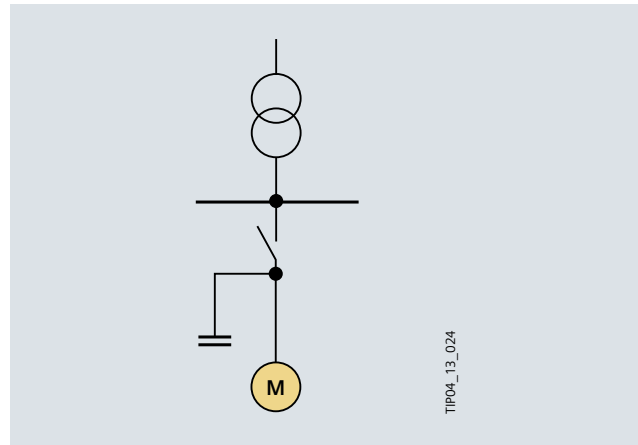

Fig. 5/16: Single compensation

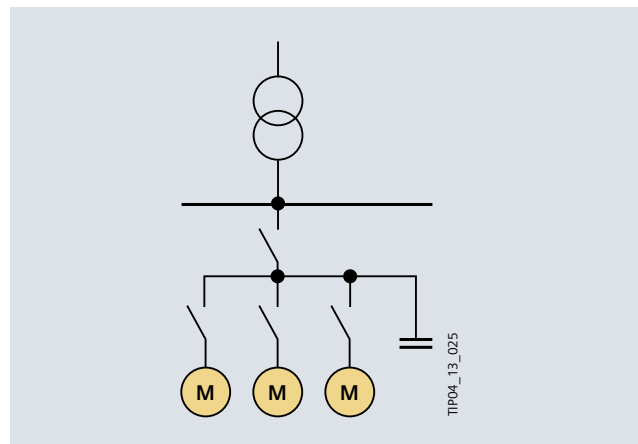

Fig. 5/17: Group compensation

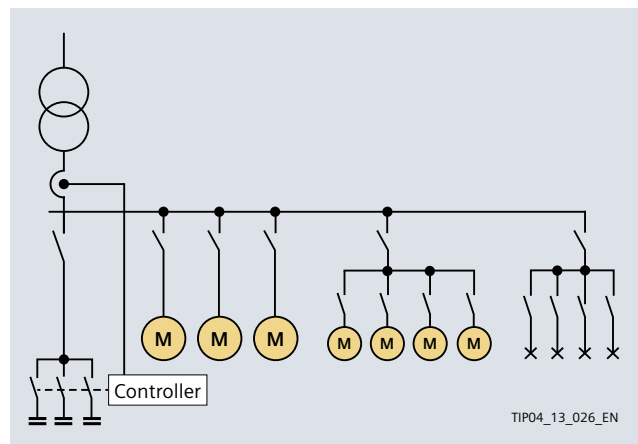

Fig. 5/18: Central compensation

### 5.4.2 Ripple Control System

Ripple control systems are used for remote control of power consumers in the power supply network (night-storage heaters, street lights, etc.). The latter also functions as a transmission path. Control commands are transmitted by means of pulse sequences in the range of 167 to approx. 2,000 Hz which are superimposed on the voltage with an amplitude of approx. 1 – 8% of the respective nominal power system voltage. The audio frequency (AF)<sup>1</sup> is switched on and off for transmission following a code (pulse grid), which creates a “telegram”. The consumer to be remote-controlled is downstream-connected to a special receiver (ripple control receiver) which filters the pulse telegrams out of the network and deduces the desired control information from them (Fig. 5/19).

An existing ripple control frequency in the network must absolutely be observed when compensation units are selected, because an impairment of ripple control is not permitted. Audio frequencies in ripple control are crucial for different reactive power compensation types. [2] presents a selection scheme conditional upon the ripple control frequencies and boundary conditions in the network. By the electrical power distribution systems being enhanced to smart grids, audio frequency ripple control systems will become less important and planning compensation systems will become easier.

### 5.4.3 Compensation in Networks with Harmonic Content

In contrast to linear loads such as incandescent lamps, three-phase motors, or resistance heaters, non-linear loads such as power converters, single-phase, clocked power supplies, or energy-saving lamps create distortions of the line voltage as described in section 5.1. The harmonic currents connected with the distortions are forced upon the network and influence other power consumers in the network.

If the proportion of harmonic-generating loads is 15% and more (referred to the total load), reactor-connected capacitors, tuned filter circuits, or active filters should be used for compensation. Tuned filter circuits are used in particular in LV systems with extremely high harmonic loads. Active filters for filtering harmonic loads provide advantages when hardly any reactive power of the fundamental harmonics has to be compensated.

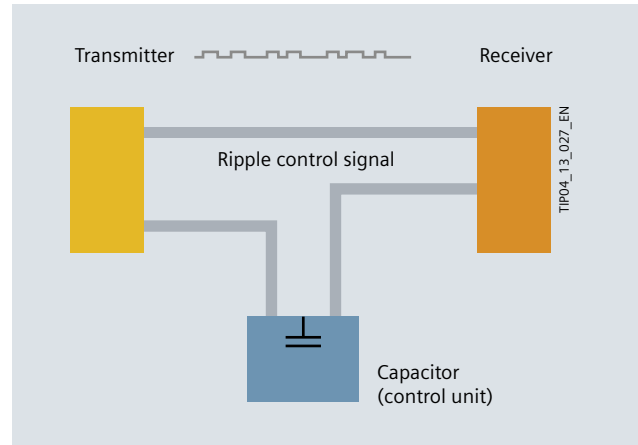

Fig. 5/19: Schematic diagram of the compensation in a network with an audio frequency ripple control system

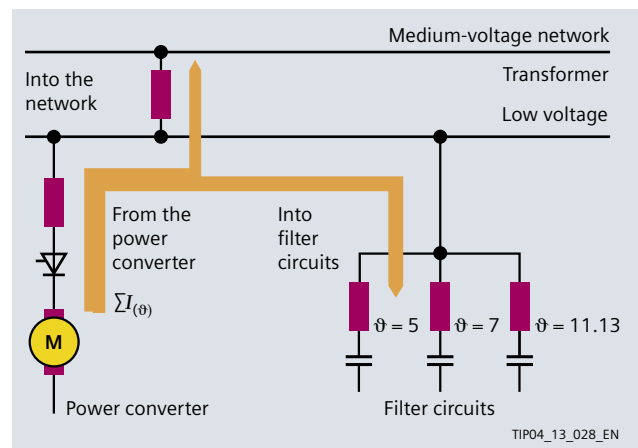

Fig. 5/20: Reactor-connected capacitors for reactive power compensation

#### Reactor-connected capacitors

Together with the inductive loads in the network, the capacitors of the reactive power compensation form a resonant circuit as described in section 5.4.1. When the resonance frequency of this resonant circuit coincides with a harmonic frequency, this causes a resonance increase of the harmonic voltage and thus an increase of the harmonic current. This might lead to a capacitor overload and additional loads on the network components and the connected consumers. In order to avoid such resonances, it is necessary to use choked capacitors (Fig. 5/20).

<sup>1</sup> The ripple control frequency tables for Germany, Austria, Switzerland, etc. are available at: rundsteuerung.de

1

2

3

4

5

6

7

8

9

10

11

12

13

14

15

16

17

They are designed similar to filter circuits, but their resonance frequency is below the harmonic of the 5th order. Thus, the capacitor unit becomes inductive for all harmonics present in the converter current and resonance points can no longer be excited. Choked capacitors and reactive power control units are to be used according to the same criteria; they are to be selected like normal capacitors and control units. For the choking, the tuning frequency determines the choking rate and thus the relation between choke reactance  $X_L$  and capacitor reactance  $X_C$  at system frequency.

$$f_{res} = f_N \cdot \sqrt{\frac{1}{p}}$$

- $f_{res}$  Resonance frequency in Hz
- $f_N$  Line frequency in Hz
- $p$  Choking rate of the compensation system in percent, with  $p = X_L / X_C$

By selecting the appropriate choking rate  $p$ , the resonance frequency can be forced down below the audio frequency AF, for example

AF > 160 Hz:  $p = 14\%$

AF > 250 Hz:  $p = 7\%$

AF > 350 Hz:  $p = 5.67\%$

Thyristor-switched compensation (Fig. 5/21) is a special variant of choked compensation. With the electronic switching using a thyristor bridge and quick measured value acquisition, switching current loads as occurring with a power contactor are avoided. This reduces the interferences for sensitive consumers in the network.

**Tuned filter circuits (passive filters)**

Tuned filter circuits are built from series resonant circuits which consist of capacitors with upstream-connected reactors. These resonant circuits are tuned in such a way that they form resistors for the individual harmonic currents which are near zero and thus smaller than the resistors of the remaining network. Therefore, the harmonic currents originating from power converters are absorbed by the filter circuits to a large extent. Only a small rest flows into the higher-level three-phase system so that the voltage is hardly distorted and a negative influence on other power consumers is ruled out (Fig. 5/22).

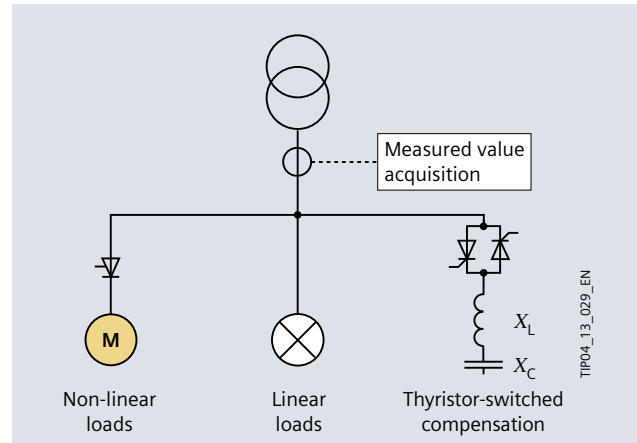

Fig. 5/21: Harmonic current suppression and reactive power compensation using filter circuits

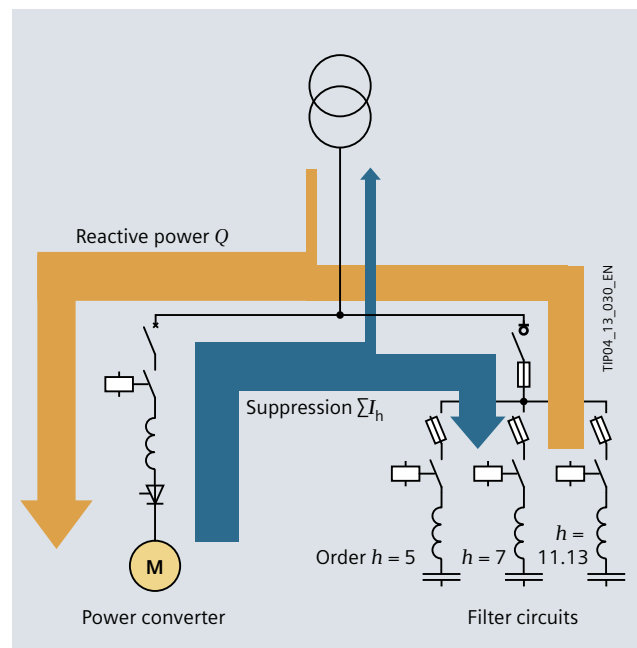

Fig. 5/22: Choked capacitors with thyristor control

As filter circuits always represent a capacitive resistance for the fundamental component of the three-phase system, they also absorb a capacitive fundamental current besides the harmonic currents. At the same time, they thus contribute to reactive power compensation of the power converters and other power consumers installed in the network.

Filter circuits must always be built up from the lowest occurring ordinal number upwards and connected accordingly. Whereas disconnection is effected from the highest ordinal number to the lowest. They are used for harmonics of the 5th, 7th, as well as the 11th and 13th order (mostly in one common absorption circuit). In many cases, filter circuits for the harmonic of the 5th order only are sufficient.

The filter circuits are dimensioned in relation to:

- The harmonic currents of the power consumers
- The harmonic content of the higher-level network voltage
- The short-circuit reactance at the point of connection

Please note that filter circuit systems or choked compensation systems must not be operated with unchoked compensation systems in parallel on the same busbar. Otherwise, unwanted parallel resonances could occur.

### Active filters

If there are high demands on the power quality or if the harmonics vary considerably with regard to amplitude and frequency, active filters should be used. For that, self-commutated, high-frequency switching power converters are used, mostly with insulated gate bipolar transistors (IGBTs), which can replicate virtually every current or voltage curve. By constantly feeding in the "negative" (i.e., phase-shifted by 180°) harmonic range, the network is impressed an almost sinusoidal waveform.

*Attention: Filters must not be installed in the PEN conductor of installation systems.*

When the active filter is connected in parallel, a current spectrum that is phased inversely to the harmonic currents is generated and added to the consumer current, resulting in an almost sinusoidal line current. Accordingly, with a series connection, the voltage quality for sensitive consumers that are to be protected is improved.

Active filters can very well compensate low-frequency harmonics, for example, harmonics of the 5th, 7th, 11th, and 13th order, but due to the switching pulse of the power electronic devices in the kHz range, no harmonics of the 50th order (which corresponds to 2,5 kHz) and higher.

For further information on the dimensioning of compensation systems and filters, please visit: [modl.de](http://modl.de)

## 5.5 Protection Against Lightning Current and Overvoltage

Overvoltages considerably damage electric and electronic appliances. This includes even small voltage peaks on the supply line. This can be seen from the damage caused to lines, circuit boards, or switchgear. Such damage can be prevented with suitable protection measures against surge currents and overvoltages.

Overvoltages are caused by lightning discharge (LEMP – lightning electromagnetic pulse), switching operations (SEMP – switching electromagnetic pulse), and electrostatic discharge (ESD). They occur in a fraction of a second only. Therefore, they are also called transient voltages or transients (from the Latin *transire* = pass). They have very short rise times of a few microseconds ( $\mu\text{s}$ ) before they drop again relatively slowly over a period of up to several 100  $\mu\text{s}$ .

The risk management described in IEC 62305-2 (VDE 0185-305-2) is preceded by a risk analysis in order to establish the necessity of lightning protection first and then define the technically and economically optimal protection measures described in IEC 62305-3 (VDE 0185-305-3) and IEC 62305-4 (VDE 0185-305-4). To this end, the property to be protected is subdivided into a (or several) lightning

protection zone(s) (LPZ) (see Fig. 5/23). For each LPZ, the geometrical borders, relevant characteristics, lightning threat data, and kinds of damage to be considered are defined. Starting from the unprotected state of the property, the assumed risk is reduced by taking (further) protection measures until only an acceptable residual risk remains. The standard considers not only protection measures for installations with the persons, electrical and electronic systems located therein, but also for supply lines.

The protection zones are defined as follows:

### Zone 0 (LPZ 0)

Outside the building, direct lightning impact:

- No protection against lightning strike (LEMP)
- LPZ 0<sub>A</sub>: endangered by lightning strikes
- LPZ 0<sub>B</sub>: protected against lightning strikes

### Zone 1 (LPZ 1)

Inside the building, high-energy transients caused by:

- Switching operations (SEMP)
- Lightning currents

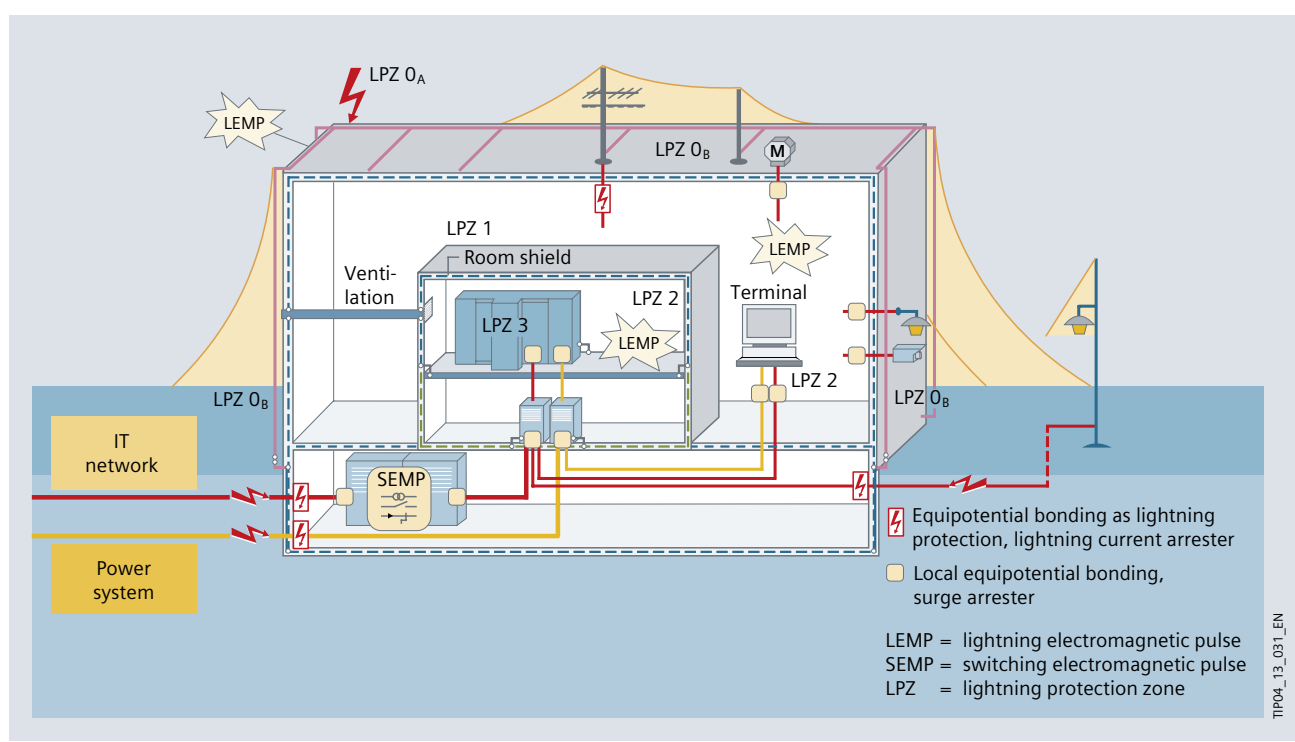

Fig. 5/23: Lightning protection zone concept



### Zone 2 (LPZ 2)

Inside the building, low-energy transients caused by:

- Switching operations (SEMP)
- Electrostatic discharge (ESD)
- An LPZ 2 which is larger than 5 m × 5 m must be subdivided

### Zone 3 (LPZ 3)

Inside the building:

- No generation of transient currents or voltages beyond the interference limit
- Protection and separate installation of circuits that could interact
- An LPZ 3 which is larger than 5 m × 5 m must be subdivided

In accordance with the IEC 62305-4 (VDE 0185-305-4), for a lightning strike it is usually to be assumed that about 50 % of the lightning current is discharged into earth via the external lightning protection system (lightning current arrester). Up to 50 % of the remaining lightning current flow into the building via electrically conductive systems such as the main equipotential bonding conductor (see Fig. 5/24). Therefore, it is always necessary to install an internal lightning protection system in addition to any existing external lightning protection system.

Current splitting, insulating interfaces, and/or surge protection devices (SPD) can limit surge currents in the internal lightning protection. The electromagnetic field of lightning can be dampened by way of spatial shielding. The impulse withstand voltage of the insulating interfaces and the protection level of the SPDs must be coordinated with the

following overvoltage categories in accordance with IEC 60664-1 (VDE 0110-1) (see Tab. 5/15).

**Overvoltage category IV:** Equipment for the use at the connecting point of the installation.

*Example: Equipment such as electricity meters and primary overcurrent protection modules.*

**Overvoltage category III:** Equipment in stationary installations and for such cases in which special demands are made on the reliability and availability of the equipment.

*Example: Equipment such as switches in stationary installations and equipment for industrial use with permanent connection to the stationary installation.*

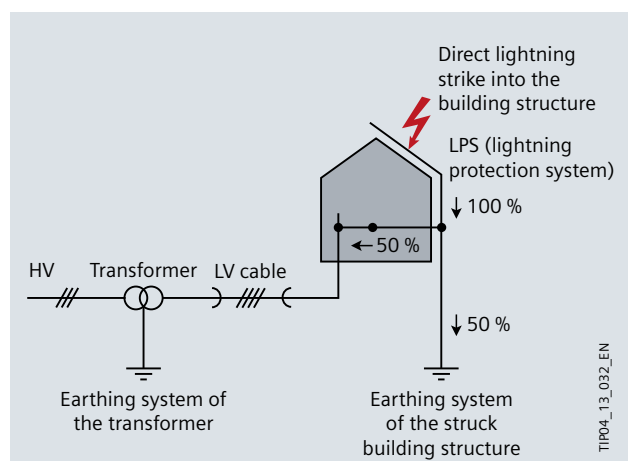

Fig. 5/24: Current splitting for a balanced lightning protection system

Nominal voltage of the power supply system (network) in acc. with IEC 60038 (VDE 0175-1)		Voltage from conductor to neutral conductor derived from the rated AC or DC voltage up to and including	Rated surge voltage			
Three-phase	Single-phase		Overvoltage category			
in V	in V	in V	I in V	II in V	III in V	IV in V
		50	330	500	800	1,500
		100	500	800	1,500	2,500
	120–240	150	800	1,500	2,500	4,000
230/400 277/480		300	1,500	2,500	4,000	6,000
400/690		600	2,500	4,000	6,000	8,000
1,000		1,000	4,000	6,000	8,000	12,000

Tab. 5/15: Overvoltage categories and rated surge voltages in acc. with IEC 60664-1 (VDE 0110-1)

**Overvoltage category II:** Energy-consuming equipment supplied by the stationary installation.

*Example: Equipment such as household appliances, portable tools, etc. and similar devices.*

**Overvoltage category I:** Equipment for the connection to circuits in which measures have been taken for a limitation of the transient overvoltages to a suitable low value.

*Example: Equipment with electronic circuits and a correspondingly low protection level.*

The term “effective protection circuit” describes a seamless measure for protection against overvoltages. The first step in the development of such a protection concept is the acquisition of all devices and system areas in need of protection. This is followed by the assessment of the required protection levels of the acquired devices. Generally, the different circuit types are differentiated into the following fields:

- Power supply
- Instrumentation and control (I&C)
- Data processing and telecommunication (transmitters/receivers)

The system or device to be protected has to be figured within a protected area. At all points of intersection “line – protection circuit”, SPDs are to be installed which correspond to the rated data of the relevant circuit or interface of the device to be protected. Thus, the area within the protection circuit is protected in such a way that cable-

bound overvoltage induction is no longer possible. Within the scope of an efficient and comprehensive protection concept against overvoltages, the power supply has to be considered in the first step. The high-energy overvoltages and surge currents occurring in this area cause flashovers over clearances in air and creepage distances as well as to earth due to the insulation of live parts and cables. Affected by this is the entire electrical equipment, from the central building supply through to the power consumer.

The measures required to protect the power supply of systems and devices depends on the results of the hazard analysis. Three protection stages are defined (see Tab. 5/16) on which an effective protection concept is based. The SPDs for the individual stages basically differ in the magnitude of the discharge capacity (surge current carrying capacity) and the protection level (maximum remaining instantaneous value of the overvoltage) depending on the relevant protection stage.

For a three-stage concept in which all SPDs are installed at different locations, a setup as shown in Fig. 5/25 Part I results.

Moreover, there are three-stage protection concepts with SPD combinations (Fig. 5/25 Part II) in which stage 1 and 2 are combined in one device, and a two-stage concept (Fig. 5/25 Part III) which can be used in the case of a low hazard potential and after conscientious examination and assessment of the hazard potential. After conscientious examination and assessment of the hazard potential for the property, the installation of a lightning current arrester of type 1 may be refrained from.

Protection stage	Designation	SPD type	Protection level	Usual installation location
1	Lightning current arrester	1	4 kV	Main distribution
2	Surge arrester	2	2.5 kV	Sub-distribution board
3	Device protection	3	1.5 kV	before the connected device

Tab. 5/16: Protection stages for a three-stage overvoltage protection concept

Contents
Introduction
1
2
3
4
5
6
7
8
9
10
11
12
13
14
15
16
17

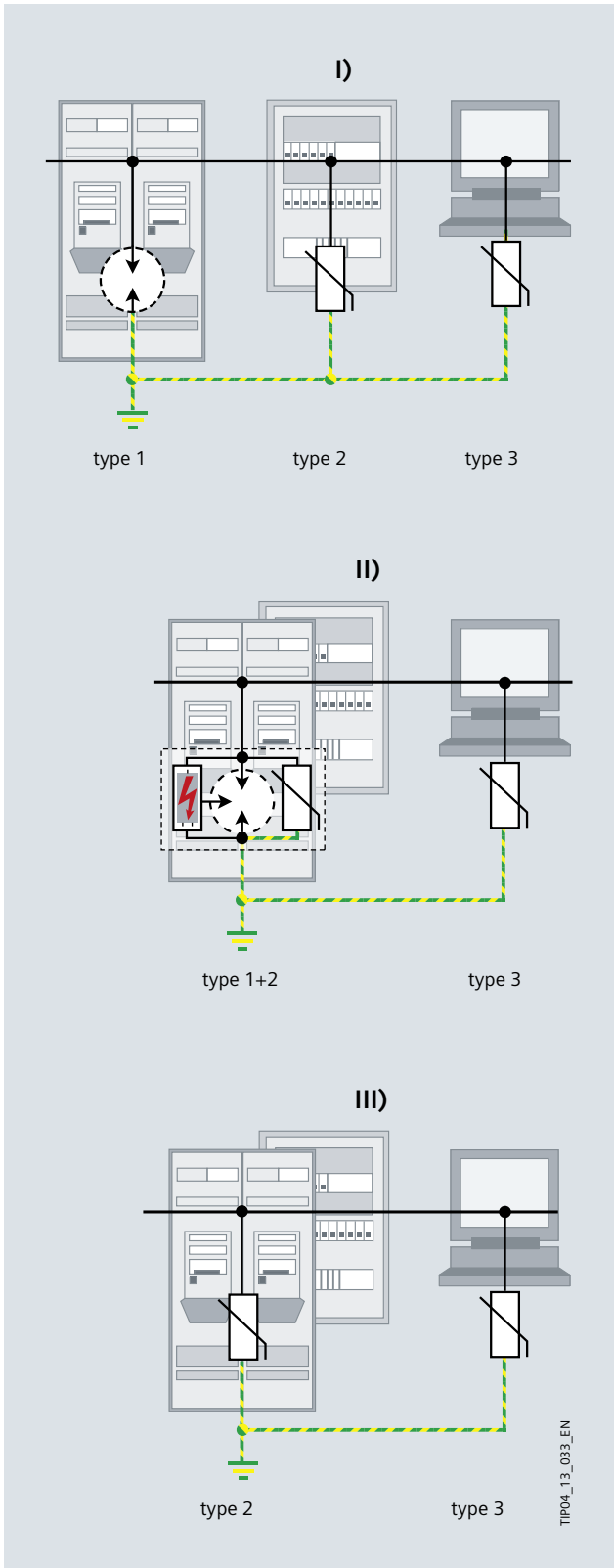

Fig. 5/25: Three protection stages with different installation locations in the power supply [back to page 94](#)

Con-  
tents

Intro-  
duction

1

2

3

4

5

6

7

8

9

10

11

12

13

14

15

16

17

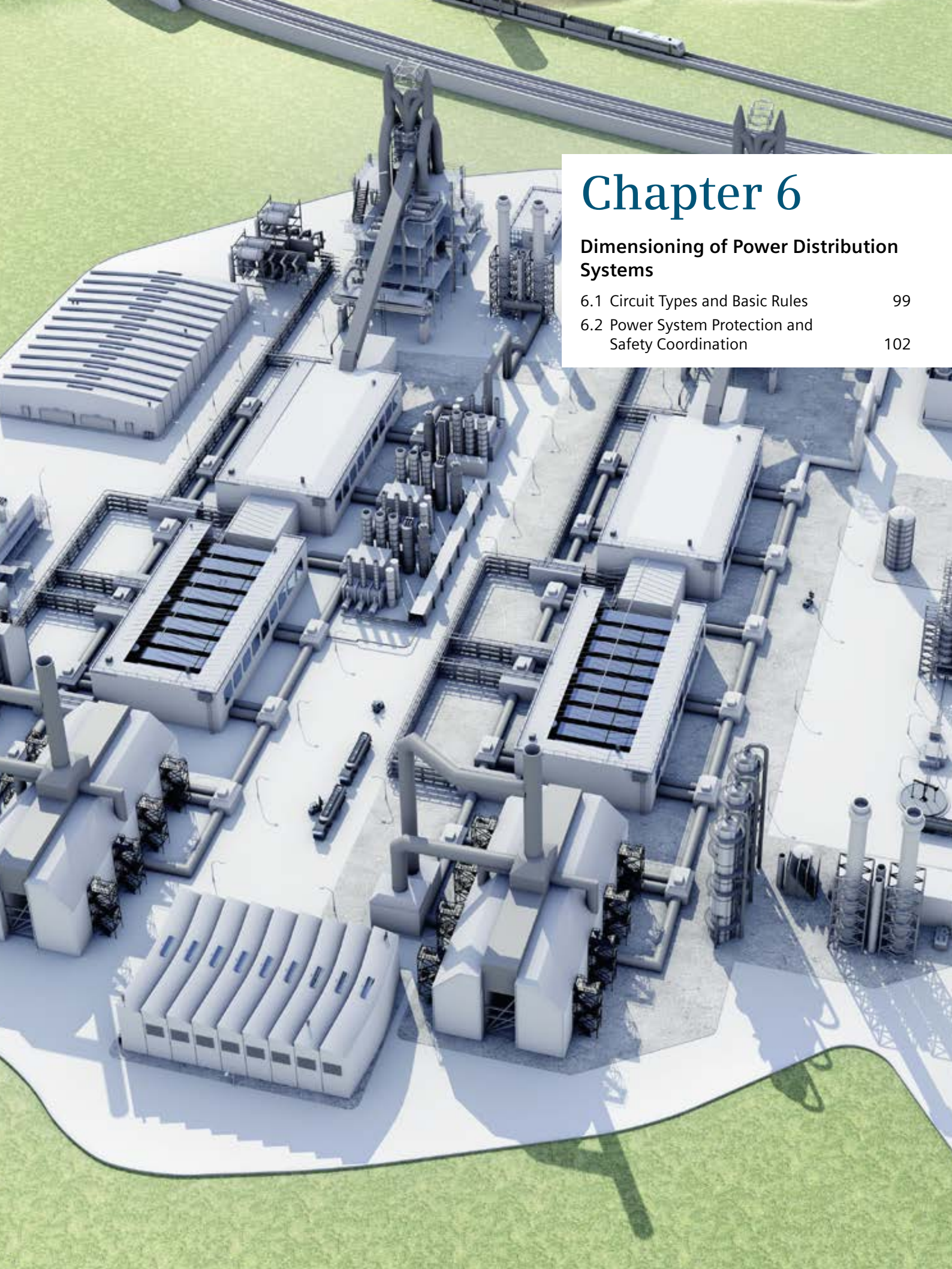

# Chapter 6

## Dimensioning of Power Distribution Systems

6.1 Circuit Types and Basic Rules	99
6.2 Power System Protection and Safety Coordination	102

# 6 Dimensioning of Power Distribution Systems

- 1
- 2
- 3
- 4
- 5
- 6
- 7
- 8
- 9
- 10
- 11
- 12
- 13
- 14
- 15
- 16
- 17

When the basic supply concept for the electricity supply system has been established, it is necessary to dimension the electrical power system. Dimensioning is the rating of all the equipment and components that are to be used within the electrical network. The dimensioning target is to obtain a technically permissible combination of switching/protection devices and connecting lines for each circuit in the power system.

### Basic rules

On principle, circuit dimensioning shall be performed in compliance with the technical rules/standards listed in Fig. 6/1. Details will be explained below.

### Cross-circuit dimensioning

When selected network components and systems are matched, an economically efficient overall system can be designed. This cross-circuit matching of network components may bear any degree of complexity, as subsequent modifications to certain components, e.g. a switch or

protection device, may have effects on the neighbouring, higher-level, or all lower-level network sections (high testing expense, high planning risk).

### Dimensioning principles

For each circuit, the dimensioning process comprises the selection of one, or more than one switching/protection device(s) to be used at the beginning or end of a connecting line, as well as the selection of the connecting line itself (cable/line or busbar connection) under consideration of the technical features of the corresponding switching/protection devices. For supply circuits in particular, dimensioning also includes rating the power sources.

Depending on the circuit type, there may be different focal points of dimensioning, as demonstrated below. The dimensioning target of overload and short-circuit protection can be attained in correlation to the mounting location of the protection equipment. For example, devices mounted at the end of a connecting line can, at best, ensure overload protection for this line, not, however, short-circuit protection!

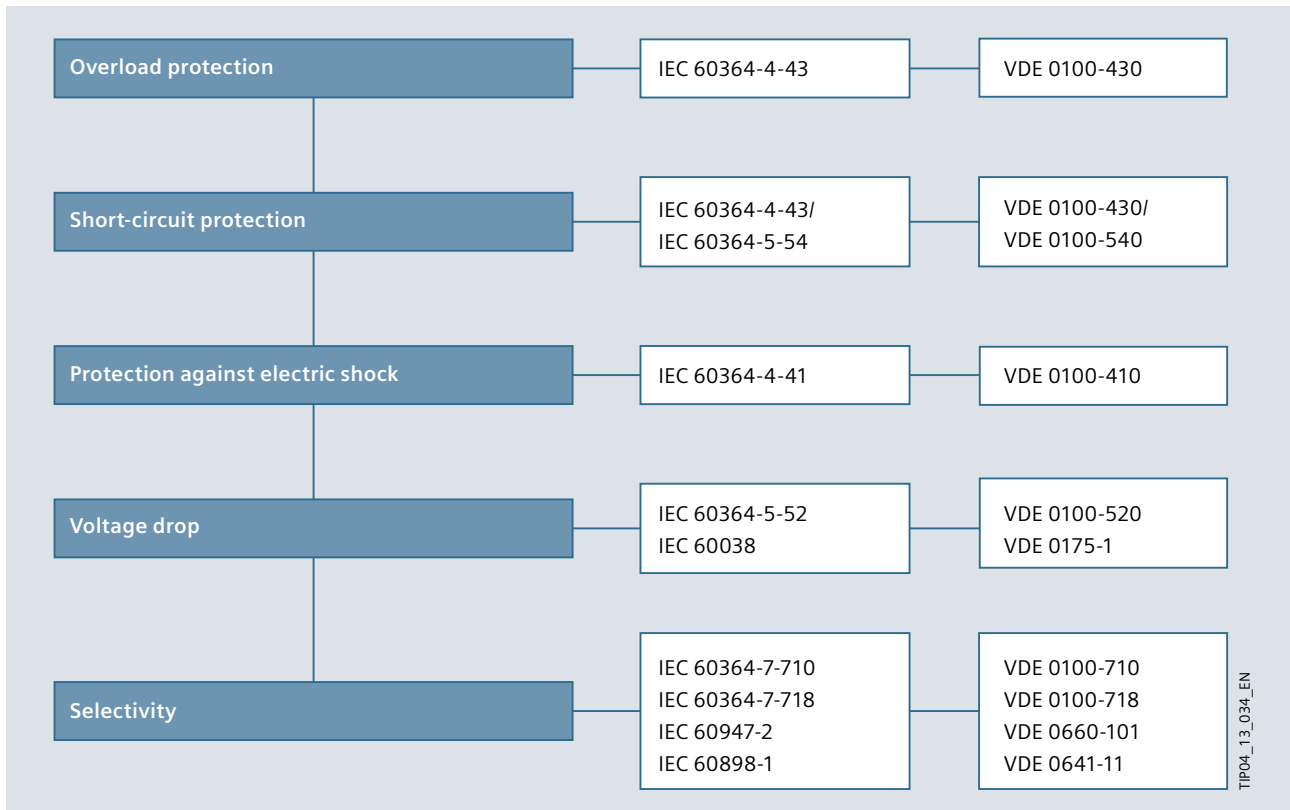

Fig. 6/1: Standards for dimensioning protection devices and routing in circuits

## 6.1 Circuit Types and Basic Rules

The basic dimensioning rules and standards listed in section 6.1 principally apply to all circuit types. In addition, there are specific requirements for these circuit types (see section 6.2) which will be explained in detail below.

### Supply circuits

Particularly high requirements apply to the dimensioning of supply circuits. This starts with the rating of the power sources. Power sources are rated according to the maximum load current to be expected for the power system, the desired amount of reserve power, and the degree of supply reliability required in case of a fault (overload / short circuit).

Load conditions in the entire power system are established by taking the energy balance. Reserve power and operational safety in the vicinity of the supply system are usually established by building up appropriate redundancies, for example by

- Providing additional power sources (transformer, generator, UPS)
- Rating the power sources according to the failure principle, n- or (n-1) redundancy: applying the (n-1) principle means that two out of three supply units are principally capable of continually supplying the total load for the power system without any trouble if one power source fails (also see chapter 5)
- Rating those power sources that can temporarily be operated under overload (for example using vented transformers)

Independent of the load currents established, dimensioning of any further component in a supply circuit is oriented to the ratings of the power sources, the system operating modes configured and all the related switching states in the vicinity of the supply system.

As a rule, switching / protection devices must be selected in such a way that the planned power maximum can be transferred. In addition, the different minimum / maximum short-circuit current conditions in the vicinity of the supply system, which are dependent on the switching status, must be determined. When connecting lines are rated (cable or busbar trunking system), appropriate reduction factors must be taken into account, which depend on the number of systems laid in parallel and the installation type.

When devices are rated, special attention should be paid to their rated short-circuit breaking capacity. You should also opt for a suitable switch (air circuit-breaker or moulded-case circuit-breaker) with a high-quality tripping unit and variable settings, as this component is an important basis

for attaining the best possible selectivity towards all upstream and downstream devices.

### Distribution circuit

Dimensioning of cable routes and devices follows the maximum load currents to be expected at this distribution level. As a rule:

$$I_{bmax} = \Sigma \text{ installed capacity} \cdot \text{simultaneity factor}$$

Switching / protection device and connecting line are to be matched with regard to overload and short-circuit protection. In order to ensure overload protection, you must also observe the standardised conventional (non-)tripping currents referring to the device applied. A verification based merely on the rated device current or the setting value  $I_r$  is not sufficient.

The following basic rules must be observed to ensure overload protection:

### Rated current rule

*Non-adjustable protection equipment*

$$I_B \leq I_n \leq I_Z$$

The nominal current  $I_n$  of the selected device must be in between the established maximum load current  $I_B$  and the maximum permissible load current  $I_Z$  of the selected transmission medium (cable or busbar trunking system).

*Adjustable protection equipment*

$$I_B \leq I_r \leq I_Z$$

The setting value of the overload tripping unit  $I_r$  of the selected device must be in between the established maximum load current  $I_B$  and the maximum permissible load current  $I_Z$  of the selected transmission medium.

### Tripping current rule

$$I_2 \leq 1.45 \cdot I_Z$$

The maximum permissible load current  $I_Z$  of the selected transmission medium must be above the high test current  $I_2 / 1.45$  of the selected device. The high test current  $I_2$  is standardised and varies according to type and characteristics of the protection equipment applied.

The following basic rules must be observed to ensure short-circuit protection:

**Short-circuit energy**

$$K^2 S^2 \geq I^2 t$$

(*K* = material coefficient; *S* = cross section)

The amount of energy that is set free from the moment when a short circuit occurs, until it is cleared automatically, must at any time be less than the energy which the transmission medium can carry as a maximum before irreparable damage is caused. According to IEC 60364-4-43 (VDE 0100-430) this basic rule is valid up to a time range of max. 5 s. Below a short-circuit clearing time of 100 ms, the let-through energy of the protection device must be factored in (see device manufacturer data).

When devices with a tripping unit are used, observance of this rule across the entire characteristic device curve must be verified. A mere verification in the range of the maximum short-circuit current applied (*I<sub>kmax</sub>*) is not always sufficient, in particular, when time-delayed releases are used.

**Short-circuit time**

$$t_a (I_{kmin}) \leq 5 \text{ s}$$

The resulting current breaking time of the selected protection equipment must ensure that the calculated minimum short-circuit current *I<sub>kmin</sub>* at the end of the transmission line or protected line is automatically cleared within 5 s at the latest. Overload and short-circuit protection needn't necessarily be provided by one and the same device. If required, these two protection targets may be accomplished by a device combination. The use of separate switching/protection devices could also be considered, i.e. at the start and end of a cable route. As a rule, devices applied at the end of a cable route can ensure overload protection for this line only.

**Final circuits**

The method for coordinating overload and short-circuit protection is practically identical for distribution and final circuits. Besides overload and short-circuit protection, the protection of human life is also important for all circuits.

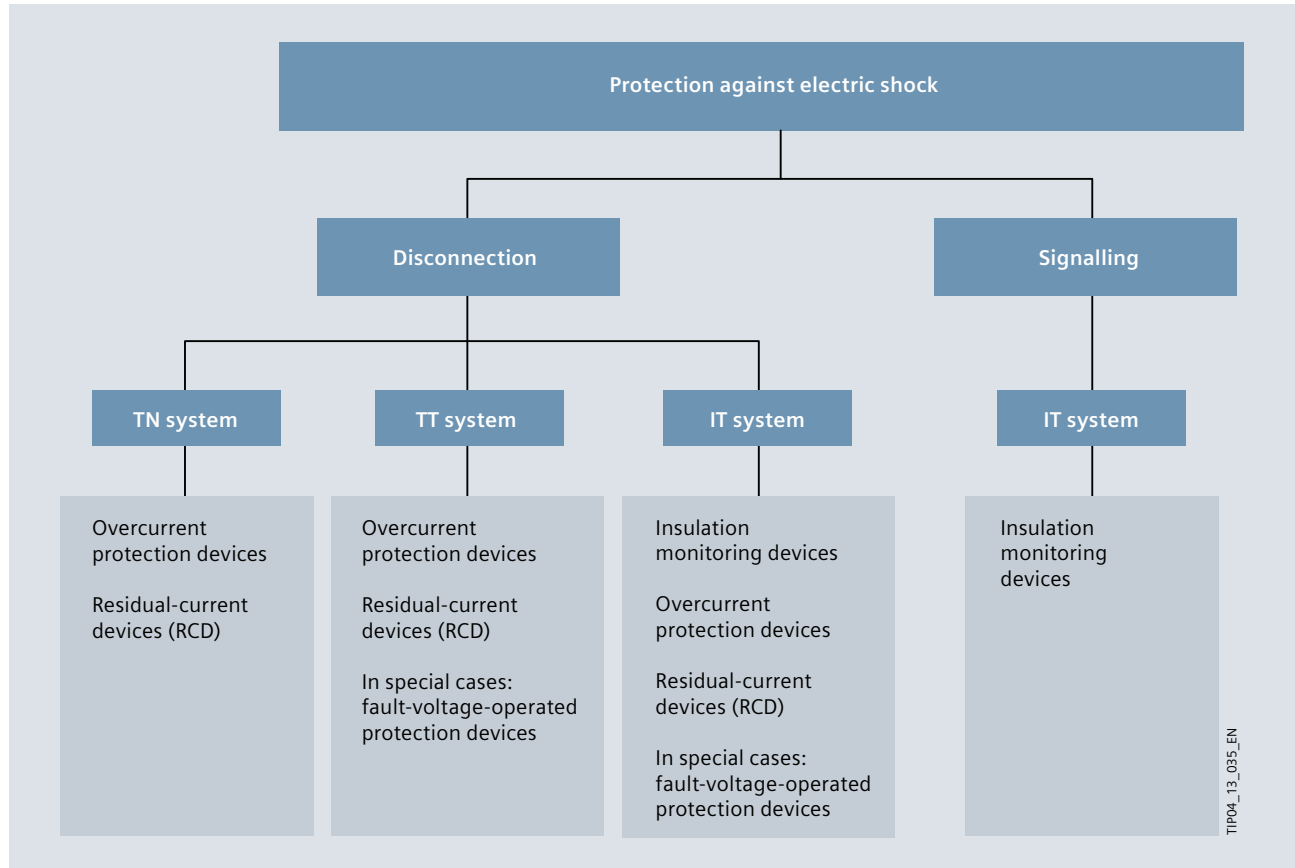

Fig. 6/2: Dependency of personal protection on power supply systems

[back to page 101](#)



### Permissible voltage drop

For cable dimensioning, the maximum permissible voltage drop must be factored in. This means that the chain: voltage drop – cable diameter – bending radiuses – space requirements also influences the room size and costs to be taken into account for planning.

### Protection against electric shock

$$t_a(I_{k1 \min}) \leq t_{a \text{ perm.}}$$

If a 1-phase fault to earth ( $I_{k1 \min}$ ) occurs, the resulting current breaking time  $t_a$  for the selected protection equipment must be shorter than the maximum permissible breaking time  $t_{a \text{ perm.}}$  which is required for this circuit according to IEC 60364-4-41 (VDE 0100-410) to ensure the protection of persons. As the required maximum current breaking time varies according to the nominal line voltage and the type of load connected (stationary and non-stationary loads), protection requirements regarding minimum breaking times  $t_{a \text{ perm.}}$  may be transferred from one load circuit to other circuits. Alternatively, this protection target may also be achieved by observing a maximum touch voltage. Depending on the power supply system, the defined protection must be built up as shown in [Fig. 6/2](#).

As final circuits are often characterized by long supply lines, their dimensioning is often greatly influenced by the maximum permissible voltage drop. As far as the choice of switching/protection devices is concerned, it is important to bear in mind that long connecting lines are characterized by high impedances and thus strong attenuation of the calculated short-circuit currents.

Depending on the system operating mode (coupling open, coupling closed) and the medium of supply (transformer or generator), the protection equipment and its settings must be configured for the worst case concerning short-circuit currents. In contrast to supply or distribution circuits where a high emphasis is placed on the selection of a high-quality tripping unit, final circuits are satisfied with a tripping unit in LI characteristic for overload and instantaneous short-circuit protection (see section 6.2.2).

### Summary

Basically, the dimensioning process itself is easy to understand and can be performed using simple means. Its complexity lies in the procurement of the technical data on products and systems, which can be found in various technical standards and regulations on the one hand and numerous product catalogues on the other.

An important aspect in this context is the cross-circuit manipulation of dimensioned components owing to their technical data, for example, the above mentioned inheritance of minimum current breaking times of the non-stationary load circuit to other stationary load or distribution circuits.

Another aspect is the mutual impact of dimensioning and network calculation (short circuit), for example when using short-circuit current limiting devices. Complexity is further increased by country-specific standards, regulations, and different installation practices applying to the two dimensioning areas. For reasons of risk minimisation and time efficiency, a number of engineering companies generally use advanced calculation software, such as SIMARIS design, to perform dimensioning and verification processes in electrical power systems.

## 6.2 Power System Protection and Safety Coordination

The objective of power system protection is to detect faults and to selectively isolate faulted parts of the system. It must also permit short clearance times to limit the fault power and the effect of arc faults.

High power density, high individual power outputs, and the relatively short distances in industrial and building power systems mean that low-voltage and medium-voltage networks are closely linked. Activities and processes in the LV network (short circuits, starting currents) also have an effect on the MV network, and vice versa, the control state of the MV network affects the selectivity criteria in the secondary power system. It is, therefore, necessary to adjust the power system and its protection throughout the entire distribution system and to coordinate the protection functions.

### 6.2.1 Terminology

Electrical installations in a power system are protected either by protection equipment allocated to the installation components or by combinations of these protection elements.

#### Standby protection

When a protection device fails, the higher-level device must take over this protection function.

#### Back-up protection

If a short circuit, which is higher than the rated switching capacity of the protection device used, occurs at a particular point in the system, back-up protection must provide protection for the downstream installation component and for the protection device by means of an upstream protection device.

#### Rated short-circuit breaking capacity

The rated short-circuit breaking capacity is the maximum value of the short-circuit current which the protection device can properly break. The protection device may be used in power systems for rated switching capacities up to this value.

#### Selectivity

Selectivity is increasingly called for as standard in invitations to tender. Often this characterizes a requirement placed on two or more overcurrent protection devices which is defined as overcurrent selectivity in the IEC 60947-1 (VDE 0660-100) standard. Due to the complexity of this issue, information about the proper selection and application of these "selective" protection devices is often insufficient. These requirements as well as the effects of full or partial selectivity in power distribution systems within the context of the relevant standard, industry, country, network configuration or type of connection to earth should be clarified in advance with the network planners, installation companies, and power system operators involved. The system interconnection together with the five rules of circuit dimensioning must also be taken into account (see Fig. 6/1).

Full selectivity is achieved with two series-connected protection devices if, when a fault occurs after the downstream protection device, only the downstream device disconnects from supply. A distinction is made between two types of selectivity:

- Type tested in accordance with IEC 60947-2 (VDE 660-101): Overcurrent discrimination of two series-connected overcurrent protection devices, where the load-side protection device takes over the full protection task up to a defined overcurrent level without the other protection device being active
- Full selectivity acc. to IEC 60947-2 (VDE 660-101): Overcurrent discrimination of two series-connected overcurrent protection devices, where the load-side protection device takes over the full protection task without the other protection device being active

*Note: Full selectivity always refers to the maximum fault current  $I_{kmax}$  at the mounting location.*

## 6.2.2 Main Characteristics of the Protection Equipment

In the context of power system protection, we will first briefly describe the protection equipment. In section 6.2.3 we will go into details of the selection criteria.

### Medium-voltage protection equipment

- HV HRC fuses (IEC 60282-1; VDE 0670-4)  
Current-limiting HV HRC fuses can only be used for short-circuit protection. They do not provide overload protection. A minimum short-circuit current is, therefore, required for correct operation. HV HRC fuses restrict the peak short-circuit current. The protection characteristic is determined by the selected rated current (Fig. 6/3)
- Medium-voltage circuit-breakers (IEC 62271-100; VDE 0671-100)  
Circuit-breakers can provide time-overcurrent protection (definite-time and inverse), time-overcurrent protection with additional directional function, or differential protection. So far, distance protection has rarely been used in infrastructure and industrial grids owing to their low spatial extension
- Secondary relays  
Secondary relays whose characteristic curves are also determined by the actual current transformation ratio are used as protection devices in medium-voltage grids. Static digital protection devices are increasingly preferred

### Low-voltage protection equipment

- LV HRC fuses (IEC 60269-2; VDE 0636-2)  
Low-voltage high-rupturing-capacity (LV HRC) fuses have a high breaking capacity. They fuse quickly to restrict the short-circuit current to the utmost degree. The protection characteristic is determined by the selected utilisation category of the LV HRC fuse (for example full-range fuse for overload and short-circuit protection, or back-up fuse for short-circuit protection only) and the rated current (Fig. 6/4)
- Low-voltage circuit breakers (IEC 60947-2; VDE 0660-101)  
circuit-breakers for power distribution systems are basically distinguished as follows:
  - Type design (open or compact design)
  - Mounting type (fixed mounting, plug-in, withdrawable)
  - Rated current (maximum nominal current of the breaker)
  - Current limiting (either current-limiting = MCCB: moulded-case circuit-breaker, or not current-limiting = ACB: air circuit-breaker)
  - Protection functions (see releases)

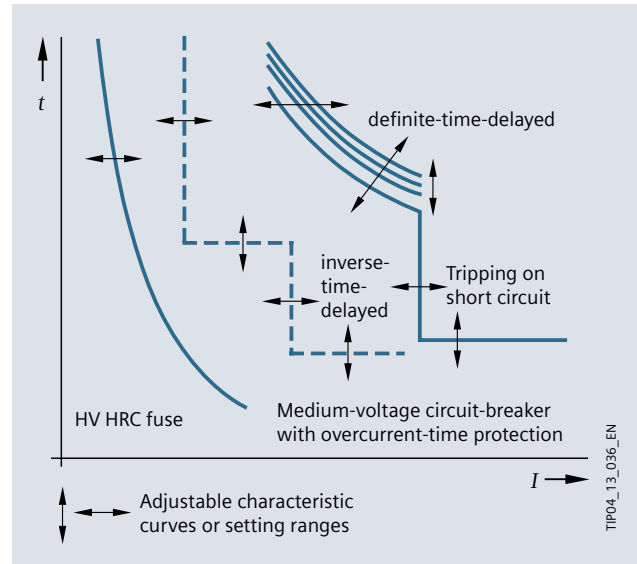

Fig. 6/3: Protection characteristic of HV HRC fuse and MV overcurrent-time protection

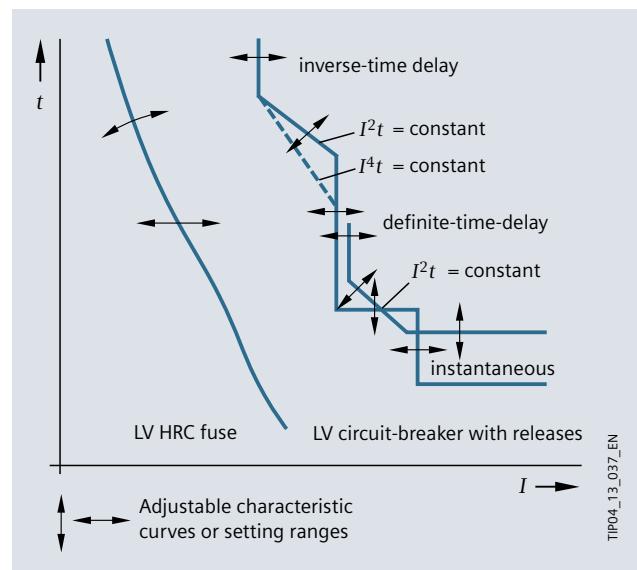

Fig. 6/4: Protection characteristic of LV HRC fuse and LV circuit-breaker with releases

- Communication capability (capability to transmit data to and from the breaker)
- Utilisation category (A or B, see IEC 60947-2; VDE 0660-101)

## Releases/protection functions

The protection function of the circuit-breaker in the power distribution system is determined by the selection of the appropriate release (see Fig. 6/5). Releases can be divided into thermo-magnetic tripping units (TMTU, previously also called electromechanical releases) and electronic tripping units (ETU).

- Overload protection  
Designation: L (LT: long-time delay), previously a-release  
Depending on the type of release, inverse-time-delay overload releases are also available with optional characteristic curves
- Neutral conductor protection  
Inverse-time-delay overload releases for neutral conductors are available in a 50 % or 100 % ratio of the overload release
- Short-circuit protection, instantaneous  
Designation: I (INST: instantaneous), previously n-release  
Depending on the application, I-releases can either be used with a fixed or an adjustable release current  $I_i$  as well as with a switch-off or non-switch-off function
- Short-circuit protection, delayed  
Designation: S (ST: short-time delay), previously z-release  
To be used for a time adjustment of protection functions in series. Besides the standard curves and settings, there are also optional functions for special applications
  - Definite-time overcurrent releases  
For this “standard S function”, the desired delay time ( $t_{sd}$ ) is defined as of a set current value (threshold  $I_{sd}$ ) (definite time, similar to the function of “definite-time overcurrent-time protection (DMT)” at the medium-voltage level)
  - Inverse-time overcurrent releases  
In this optional S function, the product of  $I^2t$  is always constant. In general, this function is used to improve the selectivity response (inverse time, similar to the function of “inverse-time overcurrent-time protection” at the medium-voltage level)
- Earth-fault protection  
Designation: G (GF: ground fault), previously g-release  
Besides the standard function (definite-time) an optional function ( $I^2t =$  current-dependent delay) is also available
- Fault-current protection  
Designation: RCD (residual current device), previously also DI (differential current interrupter) to detect differential fault currents up to 3 A, similar to the FI function for personal protection (max. 500 mA)

In addition to this, electronic tripping units offer more tripping criteria which are not feasible with electromechanical releases.

## Protection characteristics

The protection characteristic curve is determined by the rated circuit-breaker current as well as the setting and the operating values of the releases.

- Miniature circuit-breaker in accordance with IEC 60898-1 (VDE 0641-11)  
Miniature circuit-breakers (MCBs) can be distinguished by their method of operation:
  - High current-limiting or
  - Low current-limiting capacity

Their protection functions are determined by electromechanical releases:

- Overload protection by means of inverse-time-delayed overload releases, for example bimetallic releases
- Short-circuit protection by means of instantaneous overload releases, for example solenoid releases
- Low-voltage protection device combinations  
With series-connected distribution boards, it is possible to arrange the following protection devices in series relative to the direction of power flow:
  - Fuse with downstream fuse
  - Circuit-breaker with downstream miniature circuit-breaker
  - Circuit-breaker with downstream fuse
  - Fuse with downstream circuit-breaker
  - Fuse with downstream miniature circuit-breaker
  - Several parallel supply systems (with or without coupler units) with downstream circuit-breaker or downstream fuse

Current selectivity must be verified in the case of meshed LV networks. The high- and low-voltage protection for the transformers feeding power to the LV network must be harmonized and matched to ensure protection of the secondary power system. Appropriate checks must be carried out to determine the effects on the primary MV network.

In MV systems, HV HRC fuses are normally installed upstream of the transformers in the LV feeding system only. With the upstream circuit-breakers, only time-overcurrent protection devices with different characteristics are usually connected in series. Differential protection does not or only slightly affects the grading of the other protection devices.

If dimensioning tools such as SIMARIS design are used for network design, the current-time diagrams of the switches can be visualized graphically on the PC screen. In addition, the release characteristics of circuit-breakers can be interactively adjusted in SIMARIS design. These changes are immediately shown in the diagram.

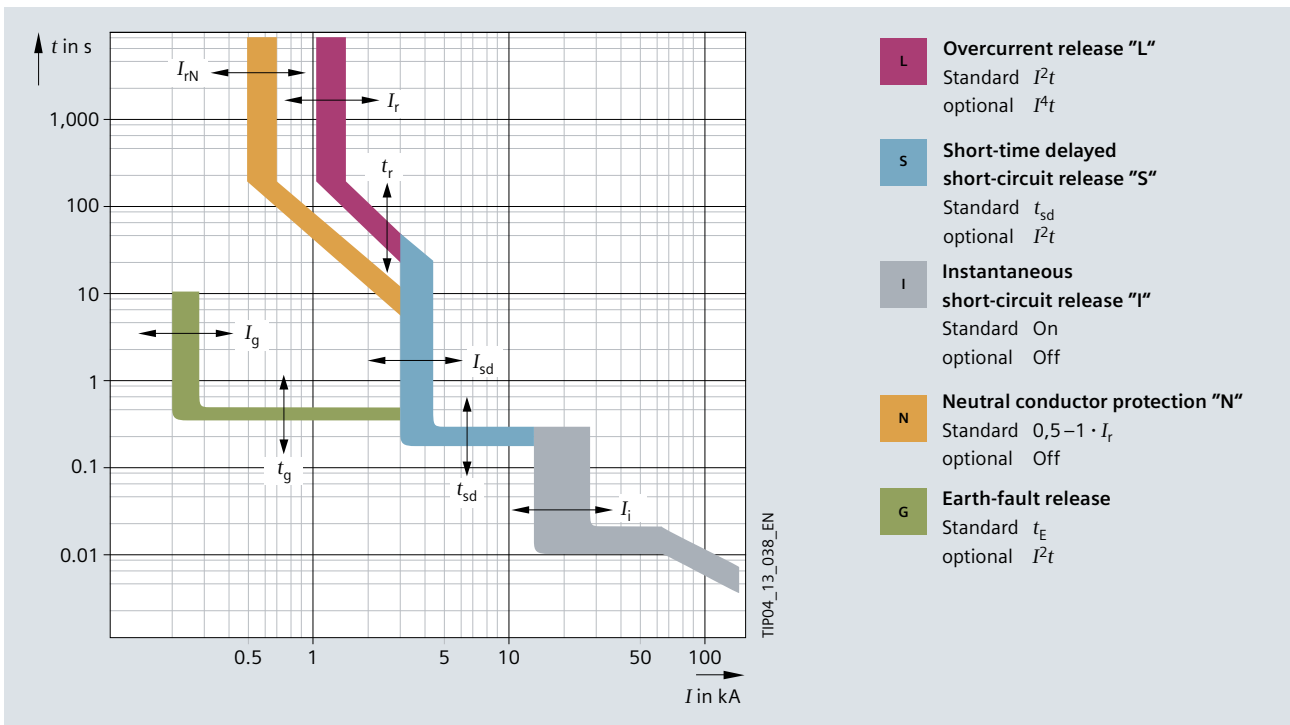

Fig. 6/5: Variants of tripping curves

[back to page 104](#)

### 6.2.3 Selectivity Criteria

- In addition to primary criteria of use such as rated current and rated switching capacity, selectivity is another important criterion for optimum supply reliability. The selective operation of series-connected protection devices is determined by the following criteria:
- Time difference for clearance (time grading) only
- Current difference for operating values (current grading) only
- Combination of time and current grading (inverse-time grading)

Direction (directional protection), impedance (distance protection), and current difference (differential protection) are also used.

#### Requirements for selective response of protection devices

Protection devices can only act selectively if both the highest ( $I_{k \max}$ ) and the lowest ( $I_{k \min}$ ) short-circuit currents for the relevant system points are known at the project configuration stage. As a result:

- The highest short-circuit current determines the required rated short-circuit switching capacity of the circuit-breaker. Criterion:  $I_{cu}$  respectively  $I_{cs} > I_{k \max}$
- The lowest short-circuit current is important for setting the short-circuit release; the operating value of this

release must be less than the lowest short-circuit current at the end of the line to be protected. Only this setting of  $I_{sd}$  or  $I_i$  guarantees that the overcurrent release can fulfil its operator and system protection functions

*Attention: When using these settings, permissible setting tolerances of  $\pm 20\%$ , or the tolerance specifications given by the manufacturer must be observed!*

Generally it is required:

$$I_{sd} \text{ or } I_i \leq I_{k \min} - 20\%$$

- The requirement that defined tripping conditions be observed determines the maximum conductor lengths or their cross sections
- Selective current grading can only be attained if the short-circuit currents are known
- In addition to current grading, partial selectivity can be achieved using combinations of carefully matched protection devices
- In principle, the highest short-circuit current can be both the three-phase and the single-phase short-circuit current
- When feeding into LV networks, the single-phase fault current will be greater than the three-phase fault current if transformers with the Dy connection are used
- The single-phase short-circuit current will be the lowest fault current if the damping zero phase-sequence impedance of the LV cable is active

Since the selectivity response of protection and switching devices made by different manufacturers is not known, products supplied by one manufacturer only should be installed throughout if the planning criterion of "selectivity" is to be fulfilled. With large installations, it is advisable to determine all short-circuit currents using a special computer program. Here, our SIMARIS design dimensioning and calculation software comes as the optimum solution.

### Grading the operating currents with time grading

Time grading also includes grading the operating currents. This means that the operating value of the overcurrent release belonging to the upstream circuit-breaker must generally be set with a factor of 1.5 higher than that of the downstream circuit-breaker. Tolerances of operating currents in definite-time-delay overcurrent S-releases ( $\pm 20\%$ ) are thus compensated. When the manufacturer specifies narrower tolerances, this factor is reduced accordingly.

Plotting the tripping characteristics of the graded protection devices together with their tolerance bands and breaker time to contact separation values in a grading diagram will help to verify and visualize selectivity.

### 6.2.4 Preparing Current-Time Diagrams (Grading Diagrams)

When characteristic tripping curves are entered on log-log graph paper, the following must be observed:

- To ensure positive selectivity, the tripping curves must neither cross nor touch
- With electronic inverse-time-delay (long-time delay) overcurrent releases (L), there is only one tripping curve, as it is not affected by pre-loading. The selected characteristic curve must, therefore, be suitable for the motor or transformer at operating temperature
- With mechanical (thermal) inverse-time-delay overload releases (L), the characteristic curves shown in the manufacturer catalogue apply to cold releases. The opening times are reduced by up to 25 % at normal operating temperatures

### Tolerance range of tripping curves

- The tripping curves of circuit-breakers given in the manufacturer catalogues are usually only average values and must be extended to include tolerance ranges
- With overcurrent releases – instantaneous (I) and definite-time delayed (S) releases – the tolerance of the variation areas may be  $\pm 20\%$  of the current setting (according to IEC 60947-2/VDE 0660 Part 101)

### Significant tripping times

For the sake of clarity, only the delay time  $t_{sd}$  is plotted for circuit-breakers with definite-time-delay overcurrent releases (S), and only the opening time  $t_o$  for circuit-breakers with instantaneous overcurrent releases (I).

### Grading principle

Delay times and operating currents are graded in the opposite direction to the flow of power, starting with the final circuit.

- Without fuses, for the load breaker with the highest current setting of the overcurrent release
- With fuses, for the fused outgoing circuit from the busbar with the highest rated fuse-link current

Circuit-breakers are used in preference to fuses in cases where fuse links with high rated currents do not provide selectivity vis-à-vis the definite-time-delay overcurrent release (S) of the transformer feeder circuit-breaker, or only with very long delay times ( $t_{sd} = 400$  to  $500$  ms). Furthermore, circuit-breakers are used where high system availability is required as they help to clear faults faster and the circuit-breakers' releases are not subject to ageing.

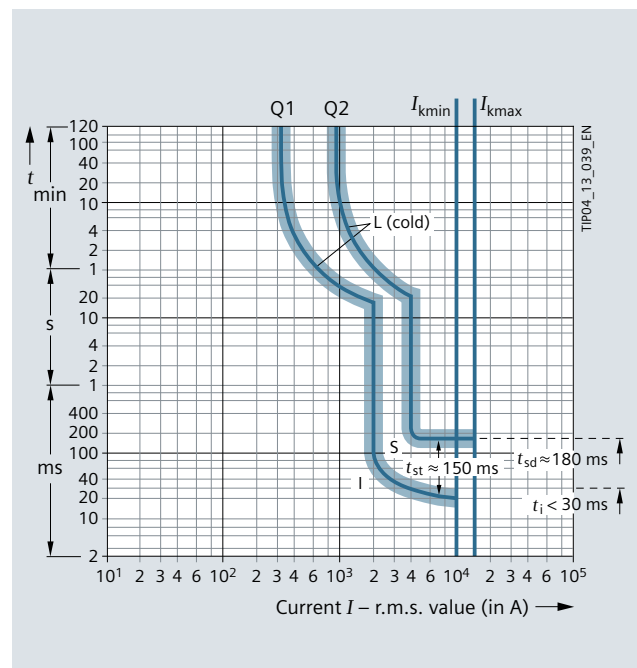

Fig. 6/6: Example of a grading diagram with tripping curves of two circuit-breakers Q1 and Q2 [back to page 107](#)

In the case of selectivity involving two or more voltage levels (for example for transformer protection), all currents and tripping curves on the high-voltage side are converted and referred to the low-voltage side on the basis of the transformer's transformation ratio.

**Tools for preparing grading diagrams**

- Standard forms with paired current values for commonly used voltages, for example for 20/0.4 kV, 10/0.4 kV, 13.8/0.4 kV
- Templates for plotting the tripping characteristics

Fig. 6/6 shows a typical grading diagram, which could also be drawn manually, with the tripping curves of two series-connected circuit-breakers that considers tolerances. When the SIMARIS design planning software is used, a manual preparation of grading diagrams is no longer necessary.

**Medium-voltage time grading**

*Tripping command and grading time*

When determining the grading time  $t_{st}$ , it must be kept in mind for the medium-voltage level that the set time elapses after the protection device was energized, before this device issues the trigger command to the shunt or under-voltage release of the circuit-breaker (command time  $t_k$ ). The release causes the circuit-breaker to open. The short-circuit current is interrupted when the arc has been extinguished. Only then does the protection system revert to the normal (rest) position (release time) (Fig. 6/7).

The grading time  $t_{st}$  between successive protection devices must be greater than the sum of the total clearance time  $t_g$  of the breaker and the release time of the protection system. Since response time tolerances, which depend on a number of factors, have to be expected for the protection devices (including circuit-breakers), a safety margin is incorporated in the grading time. Whereas grading times of less than 400 to 300 ms are not possible with protection devices with mechanical releases, electronic releases have grading times of 300 ms, and digital releases used with modern vacuum circuit-breakers even provide grading times of only 250 to 200 ms.

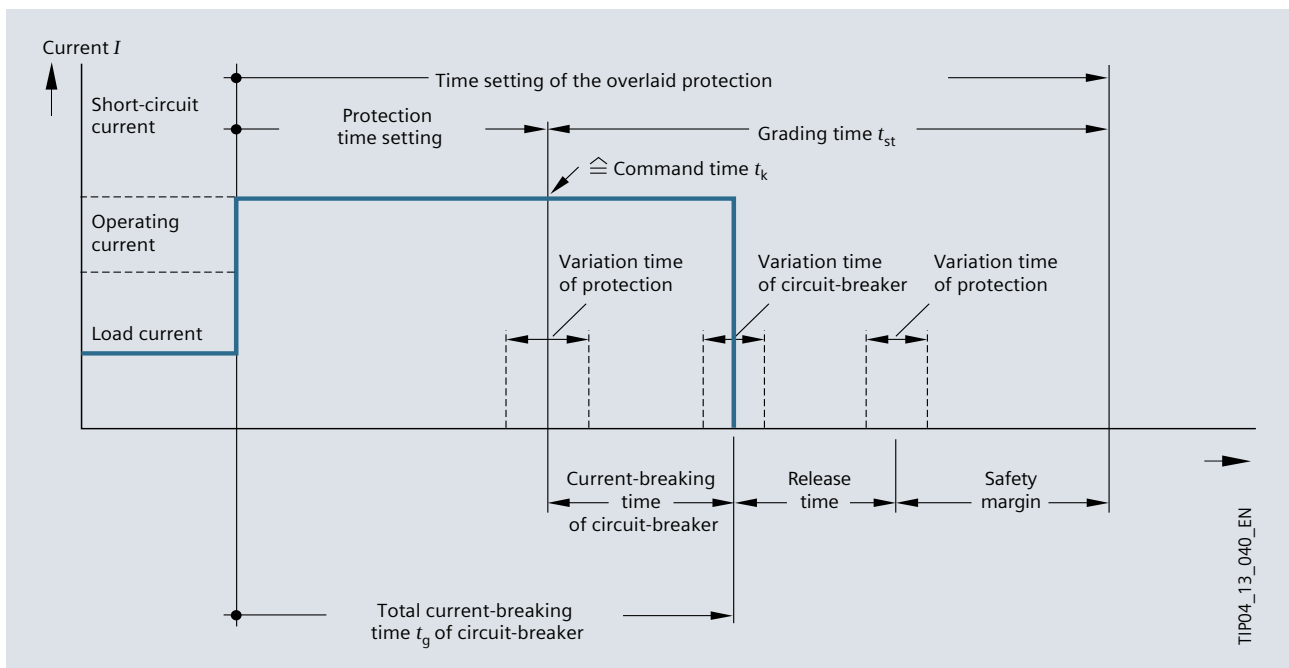

Fig. 6/7: Time grading in medium-voltage switchgear

### Low-voltage time grading

#### Grading and delay times

Only the grading time  $t_{st}$  and delay time  $t_{sd}$  are relevant for time grading between several series-connected circuit-breakers or in conjunction with LV HRC fuses (Fig. 6/8). The grading time  $t_{sd2}$  of breaker Q2 can roughly be equalized to the grading time  $t_{st2}$  and the delay time  $t_{sd3}$  of breaker Q3 is received from the sum of grading times  $t_{st2} + t_{st3}$ . The resulting inaccuracies are corrected by the calculated safety margins, which are added to the grading times.

#### Proven grading times $t_{st}$

Series-connected circuit-breakers: Those so-called "proven grading times" are guiding values. Precise information must be obtained from the device manufacturer.

- Grading between two circuit-breakers with electronic overcurrent releases should be about 70-80 ms
- Grading between two circuit-breakers with different release types (ETU and TMTU) should be about 100 ms
- For circuit-breakers with ZSI (zone-selective interlocking, i.e. short-time grading control), the grading distance of the unblocked release has been defined as 50 ms. If the release is blocked, the breaker trips within the set time  $t_{sd}$

Irrespective of the type of S-release (mechanical or electronic), a grading time of 70 ms to 100 ms is necessary between a circuit-breaker and a downstream LV HRC fuse.

### Back-up protection

In Germany, circuit-breakers must have back-up fuses with a maximum current rating of 100 A to protect them against damage by short-circuit currents. This is laid down in the Technical Supply Conditions (TAB, German: Technische Anschlussbedingungen) of the distribution system operator. According to standards (IEC, VDE), it is also permitted that a switching device be protected by one of the upstream protection devices with an adequate rated short-circuit switching capacity if both the branch circuit and the downstream protection device are also protected.

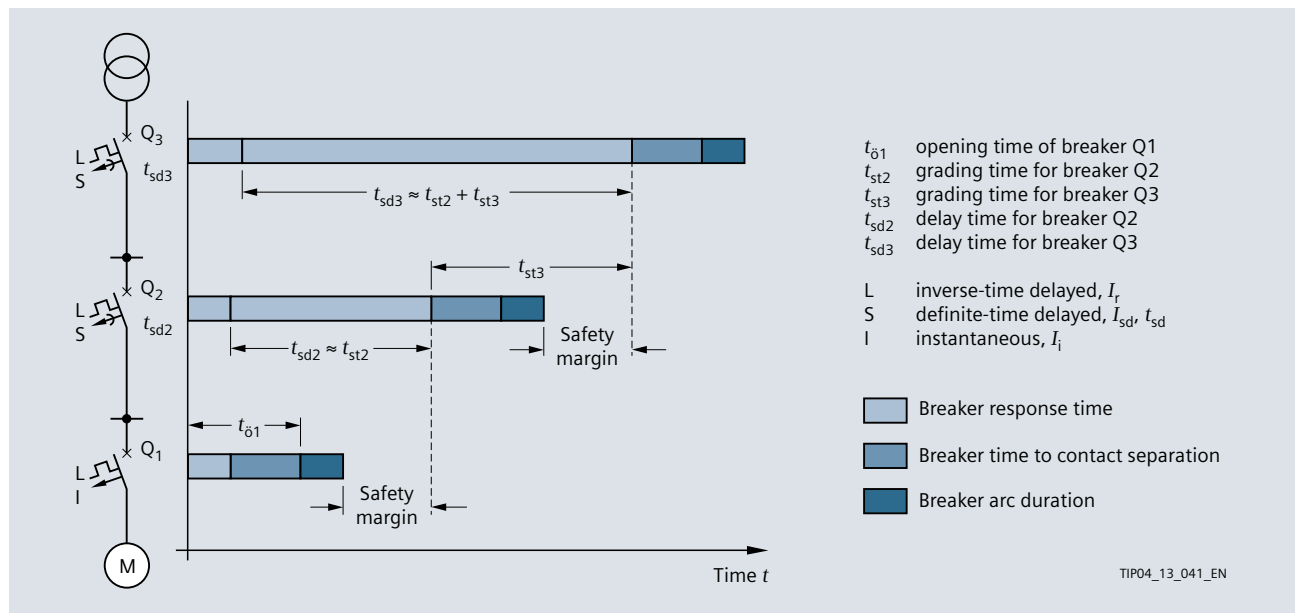
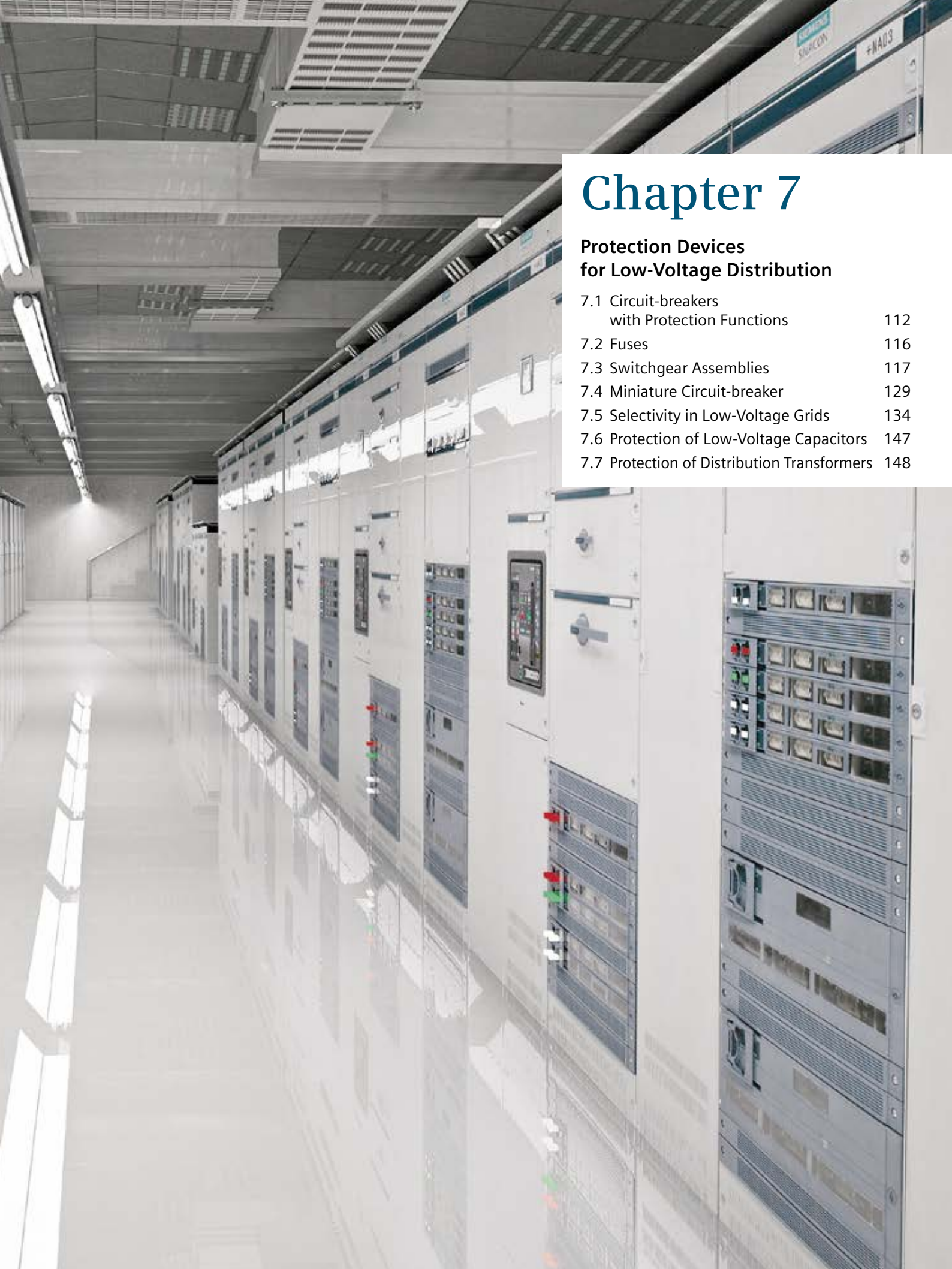

Fig. 6/8: Time grading of several series-connected circuit-breakers





# Chapter 7

## Protection Devices for Low-Voltage Distribution

7.1 Circuit-breakers with Protection Functions	112
7.2 Fuses	116
7.3 Switchgear Assemblies	117
7.4 Miniature Circuit-breaker	129
7.5 Selectivity in Low-Voltage Grids	134
7.6 Protection of Low-Voltage Capacitors	147
7.7 Protection of Distribution Transformers	148

# 7 Protection Devices for Low-Voltage Distribution

Overcurrent protection devices must be used to protect lines and cables against overheating which may result from operational overloads or dead short circuits. The protection switching devices and safety systems dealt with in this chapter are further described in chapter 8 and 11.

Tab. 7/1 and Tab. 7/2 provide an overview of the typical protection devices in low-voltage grids. Tab. 7/1 also lists the protection devices of the transformer branch circuits in the medium-voltage grid.

Protection devices used in	MV	Switch-disconnectors, HV HRC fuses		Circuit-breaker, current transformer, overcurrent protection
	LV	Circuit-breakers or LV HRC fuses	Tie breakers	Circuit-breaker
Medium-voltage side				
Transformers with temp. detectors or thermal protection				
Low-voltage side with series connection of various protection devices in radial networks		<p>Normally single and parallel operation</p>		<p>Normally single and parallel operation</p>

Tab. 7/1: Overview of protection grading schemes for transformer and LV circuits

Protection devices	Standard	Overload protection	Short-circuit protection	Excess temperature protection
Fuses gG	IEC 60269-1 / VDE 0636-1	x	x	-
Miniature circuit-breaker	IEC 60898-1 / VDE 0641-11	x	x	-
Circuit-breakers with overcurrent releases	IEC 60947-2 / VDE 0660-101	x	x	-
Partial range fuses motor protection aM	IEC 60269-1 / VDE 0636-1	-	x	-
Switchgear assembly consisting of line-side fuse in operational class gG or aM and contactor with overload relay or starter protector and contactor with overload relay	IEC 60269-1 / VDE 0636-1	-	x	-
	IEC 60947-4-1 / VDE 0660-102	x	-	-
	IEC 60947-2 / VDE 0660-101	-	x	-
	IEC 60947-4-1 / VDE 0660-102	x	-	-
Thermistor motor protection devices	IEC 60947-8 / VDE 0660-302	-	-	x

x Protection ensured    - protection not ensured

Tab. 7/2: Overcurrent protection devices for cables and lines and their protection task

[back to page 110](#)



## 7.1 Circuit-breakers with Protection Functions

Circuit-breakers mainly serve for overload and short-circuit protection and belong to the category of low-voltage switching devices. The standard basis for low-voltage switching devices in general is IEC 60947-1 (VDE 0660-100). It lists and describes their characteristic features.

In order to increase the degree of protection further, circuit-breakers can also be equipped with additional releases, for example for disconnecting upon undervoltage, or with supplementary modules for detecting fault/residual currents. They are distinguished according to their protection task as follows:

- Circuit-breakers for system protection acc. to IEC 60947-2/ (VDE 0660-101)
- Circuit-breakers for motor protection acc. to IEC 60947-2/ (DIN VDE 0660-101)
- Circuit-breakers used in motor starters acc. to IEC 60947-4-1 (VDE 0660-102)
- Miniature circuit-breakers for cable and line protection acc. to IEC 60898-1 (VDE 0641-11)

### Zero-current interrupters/current limiters

Depending on their method of operation, circuit-breakers can be designed as

- Zero-current limiters or
- Current limiters

Selective networks can more easily be designed using zero-current interrupters than by upstream protection devices, since zero-current interrupters can work with a tripping time delay across a wider current range (time selectivity). With current-limiting circuit-breakers this range covers only up to 10 to 12 times the nominal current.

Above that energy selectivity must be considered. High selectivity values for energy selectivity can only be attained by using high-quality and technically complex tripping mechanisms. Tab. 7/3 gives an overview of the overcurrent protection releases for circuit-breakers.

With regard to the tripping function of circuit-breakers two types, with corresponding current-time characteristics, can be distinguished:

- Thermal magnetic trip unit, TMTU
- Electronic trip unit (ETU) with adjustable  $I^2t$  or  $I^4t$  characteristics

Protection function	Code	Delay type of the release	Symbols acc. to IEC 60617/DIN 40713		
			Schematic symbol or		Graphic symbol
Overload protection	L LT (long time)	Inverse time delay (electronic with $I^2t$ or $I^4t$ or thermal curve of the bimetal, see Fig. 7/1)			
Selective short-circuit protection (with delay)	S <sup>1)</sup> ST (short time)	Definite time delay by time element or $I^2t$ -dependent delayed			
Earth-fault protection	G <sup>1)</sup> GF (ground fault)	Definite time delay or $I^2t$ -dependent delayed			
Short-circuit protection (instantaneous)	I INST (instantaneous)	not delayed			

<sup>1)</sup> For SENTRON 3WL and 3VA /3VL circuit-breakers by Siemens also with zone-selective interlocking (ZSI acc. to IEC/TR 61912-2).  
In the following sections, combinations of releases will only be referred to by their codes as L-, S-, and I-releases, etc.

Tab. 7/3: Symbols for releases according to protection function

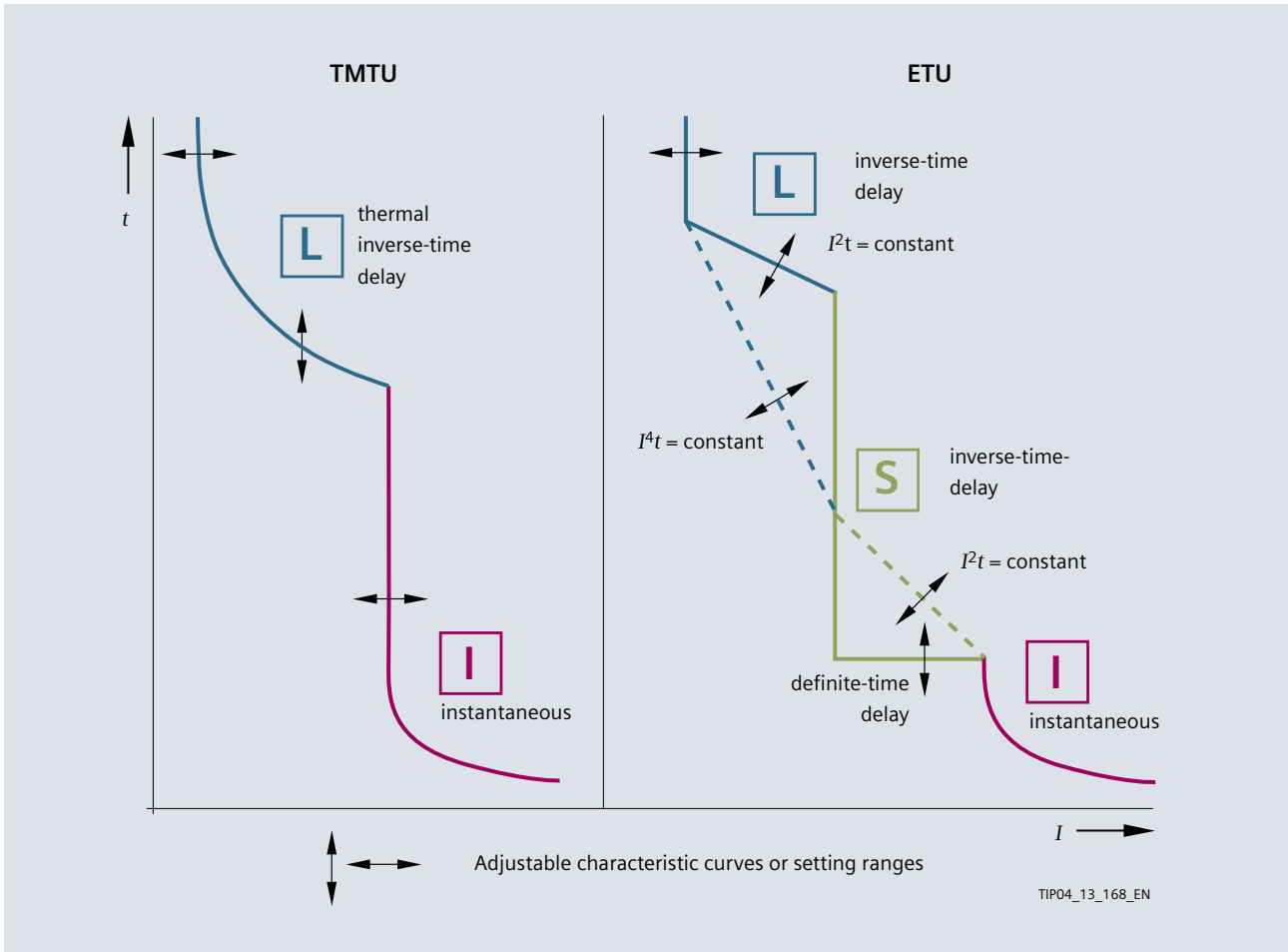

Fig. 7/1: Characteristic tripping curves for low-voltage circuit-breakers

Typical characteristic curves of circuit-breakers with ETU and TMTU are depicted in Fig. 7/1. The different tripping functions are described in the following sections.

Thermal magnetic trip units have either fixed or adjustable settings, whereas the electronic trip units used in Siemens circuit-breakers all have adjustable settings. The overcurrent releases can either be integrated in the circuit-breaker or supplied as separate modules for retrofitting or replacement. For exceptions, please refer to the manufacturers' specifications.

### Overload protection with long-time delay (L-) release

In a TMTU, inverse-time-delay overcurrent tripping (long time delay release) for overload protection is performed according to the thermal bimetal characteristic (Fig. 7/1). In Siemens circuit-breakers, the operating values for current  $I_R$  and time  $t_R$  can be set. Circuit-breakers with higher-value

ETU allow the choice between  $I^2t$  and  $I^4t$  characteristics. Possible setting ranges are schematized in Fig. 7/1.

Mechanical (thermal), inverse-time-delay overload releases are not always suitable for networks with a high harmonic content. Circuit-breakers with electronic trip units must be used in such cases.

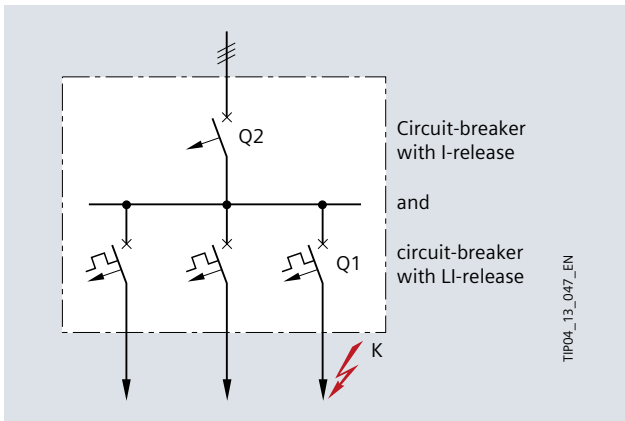

Fig. 7/2: Setting possibilities for Siemens circuit-breakers

**Short-circuit protection with short-time-delay (S) and instantaneous (I) releases**

If circuit-breakers with definite-time-delay (i.e. short-time-delay) overcurrent releases (S) are used for time-selective short-circuit protection with ETU, it should be kept in mind that the circuit-breakers are designed for a specific maximum permissible thermal and dynamic load. If the time delay causes this load limit to be exceeded in the event of a short circuit, an instantaneous release (I) must also be used to ensure that the circuit-breaker is disconnected instantaneously in case of very high short-circuit currents (Fig. 7/2). The information supplied by the manufacturer should be consulted when selecting an appropriate trip unit. Optionally, an  $I^2t$  characteristic can be used for the S-release of an ETU. The electromagnetic I-releases of a TMTU can be set.

**Reclosing lockout after short-circuit tripping**

Some circuit-breakers can be fitted with a mechanical and/or electrical reclosing lockout. It prevents reclosing to the short circuit after tripping on this fault. Only if the fault was cleared and the lockout was unlatched manually, the circuit-breaker can be closed again.

**Selection criteria for circuit-breakers**

When selecting the appropriate circuit-breakers for system protection, special attention must be paid to the following characteristics (IEC 60947-2, VDE 0660-101):

- Type of circuit-breakers and their trip units according to the respective protection function and tasks, as described above
- Rated voltages

- Rated short-circuit making ( $I_{cm}$ ) and rated short-circuit breaking capacity ( $I_{cs}$ ) as well as rated ultimate short-circuit breaking capacity ( $I_{cu}$ )
- Rated and maximum load currents

The number of phases and the type of current, AC or DC, must be indicated for the type of circuit-breaker. For AC, the rated frequency and the number of phase conductors must be given.

The system voltage and system frequency are crucial factors for selecting the circuit-breakers according to the

- Rated insulation voltage  $U_i$  and
- Rated operating voltage  $U_e$

*Rated insulation voltage  $U_i$*

The rated insulation voltage  $U_i$  is the standardised voltage value for which the insulation of the circuit-breakers and their associated components is rated in accordance with IEC 60664-1 (VDE 0110-1).

*Rated operating voltage  $U_e$*

The rated operating voltage  $U_e$  of a circuit-breaker is the voltage value to which the rated short-circuit making and breaking capacities and the short-circuit performance category refer.

The following must be specified to characterize the requirements placed on a circuit-breaker as short circuit protection device (SCPD):

*Rated short-circuit making capacity  $I_{cm}^{1)}$*

The rated short-circuit making capacity characterizes the current which an open circuit-breaker is capable of making at a voltage which corresponds to the rated voltage. It is expressed as the maximum peak value of the solid current. The following applies to  $I_{cm}$  for alternating voltage:

$$I_{cm} \geq n \cdot I_{cu} \text{ (with } n \text{ from Tab. 7/4)}$$

For direct voltage:

$$I_{cm} \geq I_{cu}$$

<sup>1</sup> A current-limiting circuit-breaker has no  $I_{cm}$  value

Short-circuit breaking capacity $I_{cu}$ (r.m.s. value in kA)	Power factor $\cos \varphi$	Minimum value for n: $n = \frac{\text{Short-circuit making capacity}}{\text{Short-circuit breaking capacity}}$
$4.5 < I_{cu} \leq 6$	0.7	1.5
$6 < I_{cu} \leq 10$	0.5	1.7
$10 < I_{cu} \leq 20$	0.3	2.0
$20 < I_{cu} \leq 50$	0.25	2.1
$50 < I_{cu}$	0.2	2.2

Tab. 7/4: Minimum values for the ratio n of [back to page 114](#) short-circuit making and ultimate short-circuit breaking capacity

### Rated short-circuit breaking capacity

The short-circuit breaking performance of the circuit-breaker is verified in accordance with IEC 60947-2 (VDE 0660-101) and can be characterized by two values:

- Rated ultimate short-circuit breaking capacity ( $I_{cu}$ ) test sequence III (switching sequence: O – t – CO with O = open, t = time, CO = closing and opening):
  - Proof of overload release (test current = twice the current set value)
  - Testing of ultimate short-circuit breaking capacity
  - Proof of dielectric strength
  - Proof of tripping on overload (test current = 2.5-fold current set value)
 Test sequence V applies to circuit-breakers with integrated fuse (see IEC 60947-2, VDE 0660-101)
- Rated service short-circuit breaking capacity ( $I_{cs}$ ) test sequence II (switching sequence: O – t – CO – t – CO with O = open, t = time, CO = closing and opening):
  - Testing of service short-circuit breaking capacity
  - Proof of operating performance
  - Proof of dielectric strength
  - Proof of heating
  - Proof of tripping on overload (test current = 1.45-fold current set value, all phases in series or with 3-phase current)

### Rated short-time withstand current $I_{cw}$

The rated short-time withstand current characterizes the permissible thermal fault withstand capability. The device can carry the specified r.m.s. value of the short-time current under the test conditions IEC 60947-1 (VDE 0660-101) for a given period of time  $t_{cw}$  without getting harmed. To do so, the circuit-breaker must be equipped with a

Rated current $I_n$ in A	Rated short-time withstand current $I_{cw}$ Minimum values
$I_n \leq 2,500$	$12 \cdot I_n$ , but at least 5 kA
$I_n > 2,500$	30 kA

Tab. 7/5: Minimum requirement for circuit-breakers with regard to rated short-time withstand current

short-circuit release with time delay. According to IEC 60947-2 (VDE 0660-101),  $I_{cw}$  must observe the minimum values of Tab. 7/5. In product data, the  $t_{cw}$  value for an  $I_{cw}$  value must always be indicated.

### Cut-off/let-through values

For zero-current interrupters, the cut-off current  $I_D$  of the circuit-breaker is equal to the solid short-circuit current. The current-limiting circuit-breaker reaches the cut-off current as the maximum momentary value during disconnecting, dependent on the solid short-circuit current. The short-circuit trip unit shall trip within a limit range of  $\pm 20\%$  of the set trip value. The manufacturer usually provides characteristic curves for the different tripping times.

The Joule integral ( $I^2t$  during disconnecting) is referred to as let-through energy. With increasing current, the let-through energy of the circuit-breaker also rises. In analogy to the cut-off current, the let-through energy of a current-limiting circuit-breaker is significantly lower than for the sine halfwave with solid short-circuit current.

### Rated circuit-breaker currents

The rated current  $I_n$  of circuit-breakers corresponds to the rated continuous current  $I_u$  from IEC 60947-1 (VDE 0660-100) and is equal to the conventional free-air thermal current  $I_{th}$ . The conventional enclosed thermal current  $I_{the}$  must be specified if it deviates from the rated current.

## 7.2 Fuses

Low-voltage high-rupturing-capacity (LV HRC) fuses have a high short-circuit breaking capacity. They fuse quickly to limit the short-circuit current. The protection characteristic is given by the selection of the operational class (see "Type" in Tab. 7/6).

The fuse classification according to application and operating voltages is specified in accordance with CLC/TR 60269-5 (VDE 0636-5) in Tab. 7/6. Full-range fuses (g) switch all overcurrents up to the rated breaking capacity, which results in fusing the fusible element. Partial range fuses (a) as back-up fuses must only be used for tripping in case of short-circuit currents and thus as protection for downstream motor starters or circuit-breakers.

Special full-range fuse-links for photovoltaic systems must comply with IEC 60269-6 (VDE 0636-6) in order to be classified as operational class gPV. Here, the rated voltage can be up to 1,000 V AC / 1,500 V DC in accordance with IEC 60269-1 (VDE 0636-1).

### Classification of LV HRC fuses and comparison of characteristics of gG and aM operational classes

LV HRC fuses are divided into interruption range (functional categories) and operational classes according to their type. They can continuously carry currents up to their rated current.

### Functional category g (full-range fuses)

Functional category g applies to full-range fuses which can interrupt currents from the minimum fusing current up to the rated short-circuit breaking current.

### Operational class gG

Fuses for interrupting overcurrents in lines and installations belong to this class. For their selection the highest operating voltage and the operating current of the circuit are determined first. According to IEC 60364-4-43 (VDE 0100-430) the following applies to the rated current of a gG fuse:

- $I_B \leq I_n \leq I_Z$  (rated current rule)
- $I_2 \leq 1.45 \cdot I_Z$  (tripping current rule)

Where

- $I_B$  Operating current of the circuit
- $I_Z$  Continuous current carrying capacity of the line
- $I_n$  Rated current of the protection device (here: fuse)
- $I_2$  Current for effective interruption of the protection device within the fixed time (conventional tripping current, now  $I_f$ )

Type	Application (characteristic curve)	Interruption range	Rated voltage V AC	Maximum operating voltage V AC
gG	General applications	Full range	230/400/500/690 V	253/440/550/725 V
gM	Protection of motor circuits	Full range	230/400/500/690 V	253/440/550/725 V
aM	Short-circuit protection of motor circuits	Partial range (back-up)	230/400/500/690 V	253/440/550/725 V
gN	North American fuse for general application and cable and line protection	Full range	600 V	600 V
gD	North American delayed fuse for general application	Full range	600 V	600 V
aR	Protection of semiconductor components	Partial range (back-up)	230/400/500/690 V <sup>2)</sup>	253/440/550/725 V <sup>1)</sup>
gR, gS	Protection of semiconductor components and cables and lines	Full range	230/400/500/690 V <sup>2)</sup>	253/440/550/725 V <sup>1)</sup>
gU	Full-range fuses for cable and line protection	Full range	230/400/500/690 V	253/440/550/725 V
gL, gF, gI, gII	Previous cable and line protection fuses (replaced by gG)	Full range		

<sup>1)</sup> In North American networks applies: Maximum operating voltage = Rated voltage <sup>2)</sup> Application-related rated voltages are possible

Tab. 7/6: Classification of LV HRC fuses based on their functional characteristics defined in CLC/TR 60269-5 (VDE 0636-5)



*Functional category a (partial-range fuses)*

Functional category "a" applies to fuses for partial-range protection, which can interrupt currents above a specified multiple of their rated current up to the rated short-circuit breaking current.

*Operational class aM*

Operational class aM applies to partial-range fuses for back-up protection of switching devices and motor starters whose minimum breaking current is approximately four times the rated current. Therefore, these fuses are only intended for short-circuit protection. The same applies to partial-range semiconductor fuses aR, which shall typically trip as of the 2.7-fold of their rated current. For this reason, fuses of functional category "a" must not be used above their rated current. A means of overload protection, for example a thermal time-delay relay, must always be provided. The prearcing time/current characteristics of LV HRC fuses of operational class gG and aM for about 200 A are compared in Fig. 7/3.

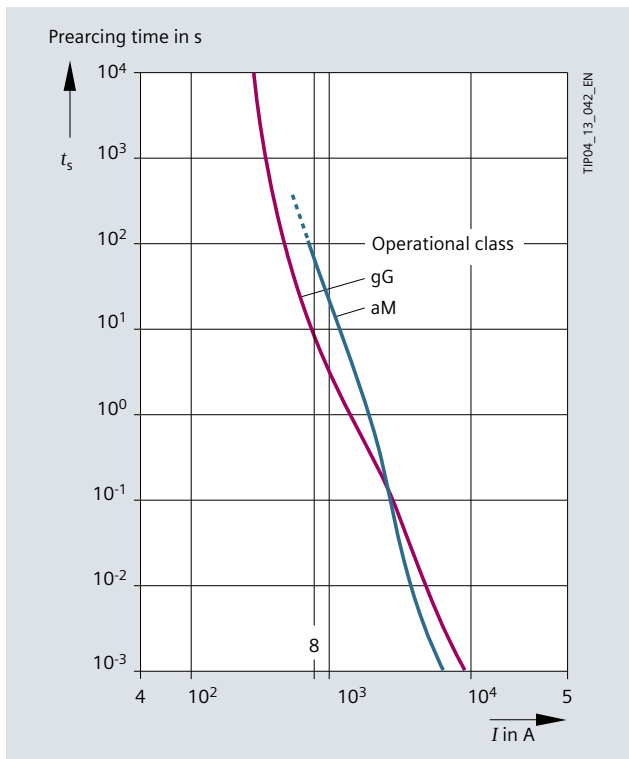

**Fig. 7/3: Comparison of characteristic curves pertaining to LV HRC fuses of operational classes gG and aM (rated current 200 A)**

### 7.3 Switchgear Assemblies

Switchgear assemblies are series-connected switching and protection devices which perform specific tasks for protecting a system component; the first device (relative to the flow of power) provides the short-circuit protection.

#### 7.3.1 Switchgear Assemblies with Fuses (Fuse-protected Design)

*Fuses and moulded-case circuit-breakers*

If the prospective short-circuit current  $I_k$  exceeds the rated ultimate short-circuit breaking capacity  $I_{cu}$  of the circuit-breaker at its mounting location, the latter must be provided with line-side fuses (Fig. 7/4).

Each device of the switchgear assembly is assigned a specific protection function. The L-release monitors overload currents, while the I-release detects short-circuit currents roughly up to the rated ultimate short-circuit breaking capacity of the circuit-breaker. This means, the circuit-breaker provides protection against all overcurrents up to its rated ultimate short-circuit breaking capacity  $I_{cu}$  and ensures all-pole opening and reclosing.

The fuses will only be responsible for interrupting the short-circuit, when higher short-circuit currents  $I_k$  are present. In this case, the circuit-breaker also disconnects all-pole almost simultaneously through its I-release, triggered by the cut-off current  $I_D$  of the fuse. The fuse must,

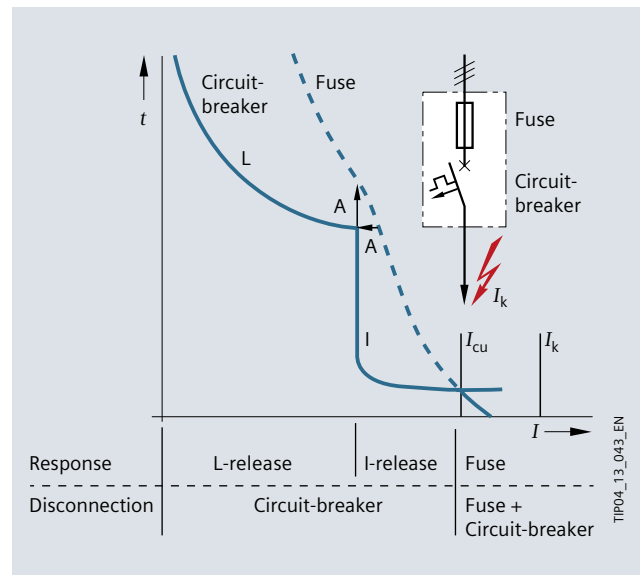

**Fig. 7/4: Switchgear assembly comprising fuse and circuit-breaker**

therefore, be selected such that its cut-off current  $I_D$  is less than the rated ultimate short-circuit breaking capacity  $I_{cu}$  of the circuit-breaker.

*Fuse, contactor, and thermal inverse-time-delay overload relay*

The switchgear assembly comprising contactor and overload relay is referred to as a motor starter or, if a three-phase motor is started directly, a direct-on-line starter. The contactor is used to switch the motor on and off. The overload relay protects the motor, motor supply conductors, and contactor against overloading. The fuse upstream of the contactor and overload relay provides protection against short circuits. For this reason, the protection ranges and characteristics of all the components (Fig. 7/5) must be carefully coordinated with each other.

*Specifications for contactors and motor starters*

The IEC 60947-4-1 (VDE 0660-102) standard applies to contactors and motor starters up to 1,000 V for direct-on-line starting (with maximum voltage). When short-circuit current protection equipment is selected for switchgear assemblies, a distinction is made between various types of protection according to the permissible degree of damage as defined in IEC 60947-4-1 (VDE 0660-102):

- Coordination type 1: Destruction of contactor and overload relay are permissible. The contactor and/or overload relay must be replaced if necessary
- Coordination type 2: The overload relay must not be damaged. Contact welding at the contactor is, however, permissible, given the contacts can easily be separated or the contactor can easily be replaced

**Protection and operating ranges of equipment**

*Grading diagram for a motor starter*

The protection ranges and the relevant characteristics of the equipment constituting a switchgear assembly used as a motor starter are illustrated in the grading diagram in Fig. 7/5. The fuses in this assembly must satisfy a number of conditions:

- The time-current characteristics of fuses and overload relays must allow the motor to be run up to speed
- The fuses must protect the overload relay from being destroyed by currents approximately 10 times higher than the rated current of the relay
- The fuses must interrupt overcurrents beyond the capability of the contactor (i.e. currents approximately 10 times higher than the rated operating current  $I_e$  of the contactor)
- In the event of a short-circuit, the fuses must protect the contactor such that any damage does not exceed the

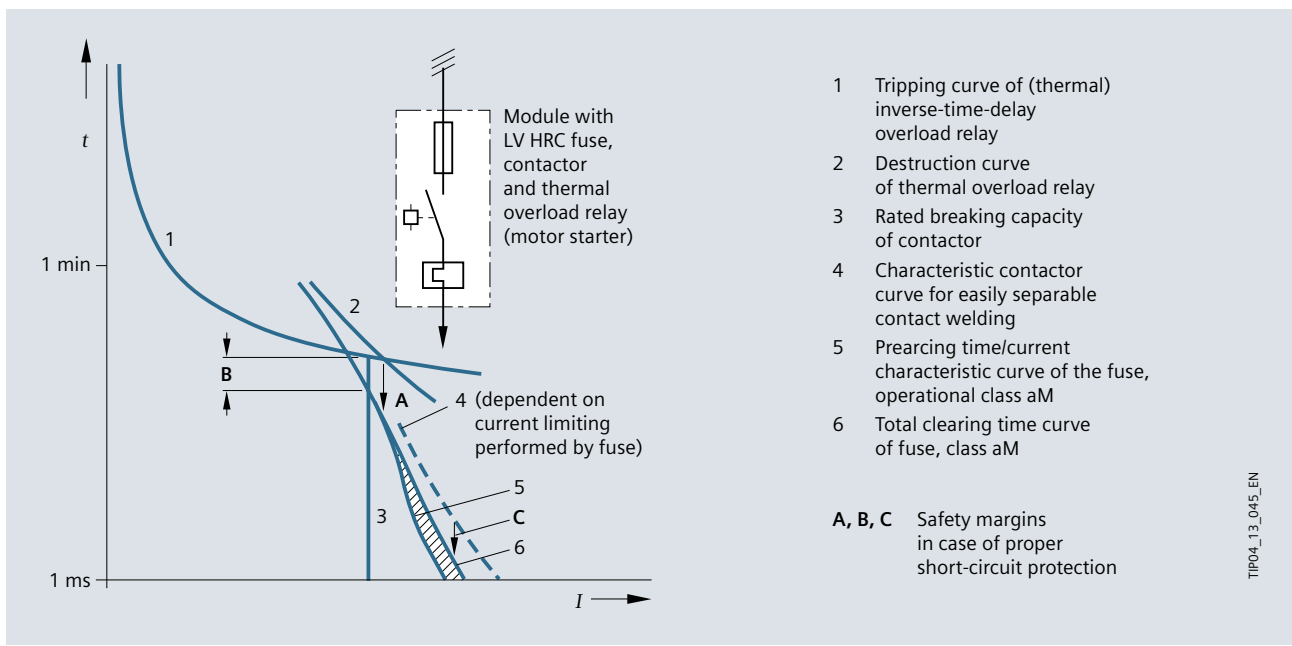

Fig. 7/5: Switchgear assembly comprising fuse, contactor, and thermal inverse-time-delay overload relay

TIP04\_13\_045\_EN

specified degrees of damage (see above). Depending on the rated operating current  $I_e$ , contactors must be able to withstand motor starting currents of 8 to 12 times the rated operating current  $I_e$  without the contacts being welded

To satisfy these conditions, safety margins (A, B, and C described below) must be maintained between certain characteristic curves of the devices.

#### *Protection of overload relay*

In order to protect the overload relay, the prearcing time/current characteristic of the fuse must lie in margin A below the intersection of the tripping curve of the overload relay (1) with its destruction curve (2) (an LV HRC switch-gear fuse of operational class aM was used in this example).

#### *Protection of contactor*

In order to protect the contactor against excessively high breaking currents, the prearcing time/current characteristic of the fuse from the current value, which corresponds to the breaking capacity of the contactor (3), must lie in margin B below the tripping characteristic of the overload relay (1).

In order to protect the contactor against contact welding, time-current characteristics, up to which load currents can be applied, can be specified for each contactor, which either result in

- No welding or
- Welded contacts that can easily be separated (characteristic curve 4 in Fig. 7/5)

In both cases, therefore, the fuse must respond in good time. The total clearing time curve of the fuse (6) must lie in margin C below the characteristic curve of the contactor for easily separable contact welding (4) (total fault-clearing time = prearcing time + extinction time).

### 7.3.2 Switchgear Assemblies without Fuses (Circuit-breaker Protected Design)

#### Back-up protection (cascade-connected circuit-breakers)

If two circuit-breakers with I-releases of the same type are connected in series along one conducting path, they will open simultaneously in the event of a fault (K) in the vicinity of the distribution board (Fig. 7/6). The short-circuit current is thereby detected by two series-connected interrupting devices and effectively extinguished. If the upstream circuit-breaker is current-limiting, the downstream circuit-breaker can be installed with a lower rated switching capacity than the maximum short-circuit current that is possibly present at its mounting location. Fig. 7/6 shows the block diagram and Fig. 7/7 the principle of a cascade connection.

The rated current of the upstream circuit-breaker Q2 is selected according to its rated operating current and thus used as main circuit-breaker or as group switch for several circuits in sub-distribution boards, for example. Its I-release is set to a very high operating current, if possible up to the rated ultimate short-circuit breaking capacity  $I_{cu}$  of the downstream circuit-breakers. Branch circuit-breaker Q1 provides overload protection and also clears autonomously relatively low short-circuit currents, which may be caused by short circuits to exposed conductive parts, insulation faults or short circuits at the end of long lines and cables. The upstream circuit-breaker Q2 only opens at the same time if high short-circuit currents flow as a result of a dead short circuit in the vicinity of branch circuit-breaker Q1.

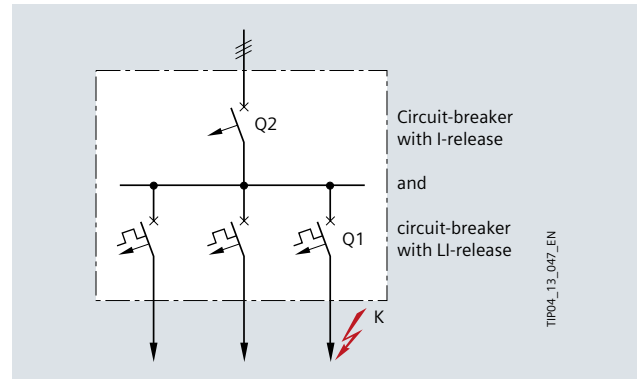

Fig. 7/6: Block diagram for a back-up protection circuit (cascade connection)

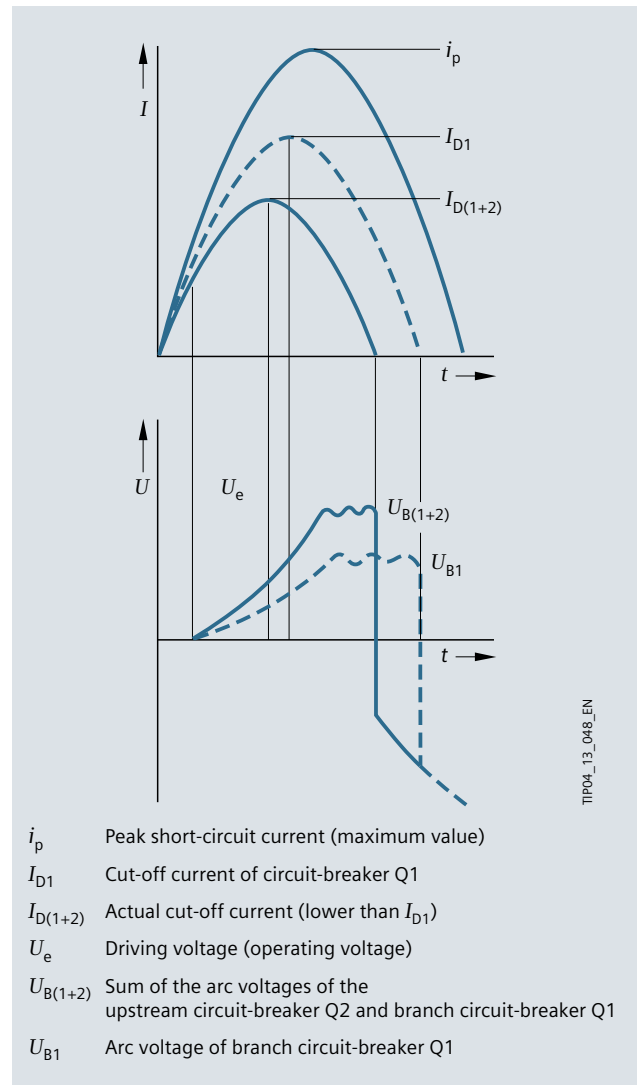

Fig. 7/7: Principle of a back-up protection circuit (cascade connection)

### Circuit-breakers with L- and I-releases and contactor

The circuit-breaker provides overload and short-circuit protection – also for the contactor – while the contactor performs switching duties (Fig. 7/8). The requirements that must be fulfilled by the circuit-breaker are the same as those that apply to the fuse in switchgear assemblies comprising fuse, contactor, and thermally inverse-time-delayed overload relay (see Fig. 7/5).

### Starter circuit-breaker with I-release, contactor, and overload relay

Overload protection is provided by the overload relay in conjunction with the contactor, while short-circuit protection is provided by the starter circuit-breaker ("starter protector"). The operating current of its I-release is set as low as the starting cycle will permit, in order to include low short-circuit currents in the instantaneous breaking range as well (Fig. 7/9). The advantage of this switchgear assembly is that it is possible to determine whether the fault was an overload or short circuit according to whether the contactor, triggered by the overload relay, or the starter circuit-breaker has opened. Further advantages of the starter circuit-breaker following short-circuit tripping are three-phase circuit interruption and immediate readiness for reclosing. Switchgear assemblies with starter circuit-breakers are becoming increasingly important in control units without fuses.

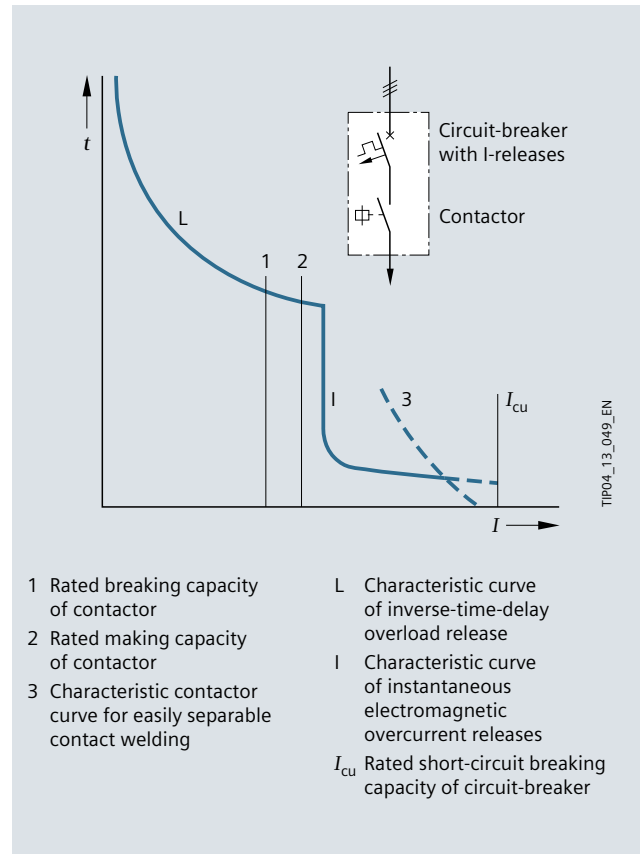

Fig. 7/8: Switchgear assembly comprising circuit-breaker and contactor

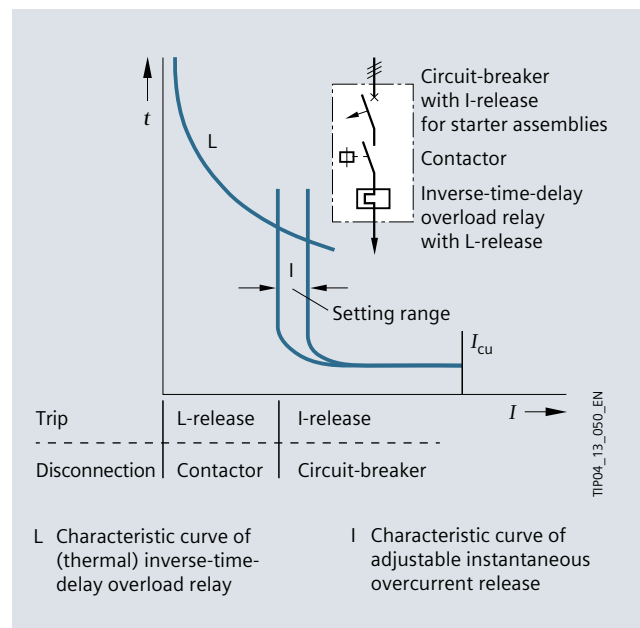

Fig. 7/9: Switchgear assembly comprising circuit-breaker, adjustable I-release, contactor, and overload relay

### 7.3.3 Switchgear Assemblies with Thermistor Motor Protection Devices

Overload relays and releases cease to provide reliable overload protection when it is no longer possible to establish the winding temperature from the motor current. This is the case with:

- High switching frequency
- Irregular, intermittent duty
- Restricted cooling
- High ambient temperature

In these cases, switchgear assemblies with thermistor motor protection devices are used. The switchgear assemblies are designed with or without fuses depending on the plant configuration. The degree of protection that can be attained depends on whether the motor to be protected has a thermally critical stator or rotor. The operating temperature, coupling time constant, and the position of the temperature sensor in the motor winding are also crucial factors. They are usually specified by the motor manufacturer.

#### Motors with thermally critical stators

Motors with thermally critical stators can be adequately protected against overloads and overheating by means of

thermistor motor protection devices without overload relays. Feeder cables are protected against short circuits and overloads either by fuses and circuit-breakers (Fig. 7/10 a) or only by fuses (Fig. 7/10 b).

#### Motors with thermally critical rotors

Motors with thermally critical rotors, even if started with a locked rotor, can only be provided with adequate protection if they are fitted with an additional overload relay or release. The overload relay or release also protects the cabling against overloads (Fig. 7/10 a, c, and d).

*Note: We recommend the use of an electronic motor protection system such as SIMOCODE (with or without thermistor protection) for motors. Advantages are: broad performance range, comprehensive control functionality, bus interfacing (PROFIBUS DP), etc.*

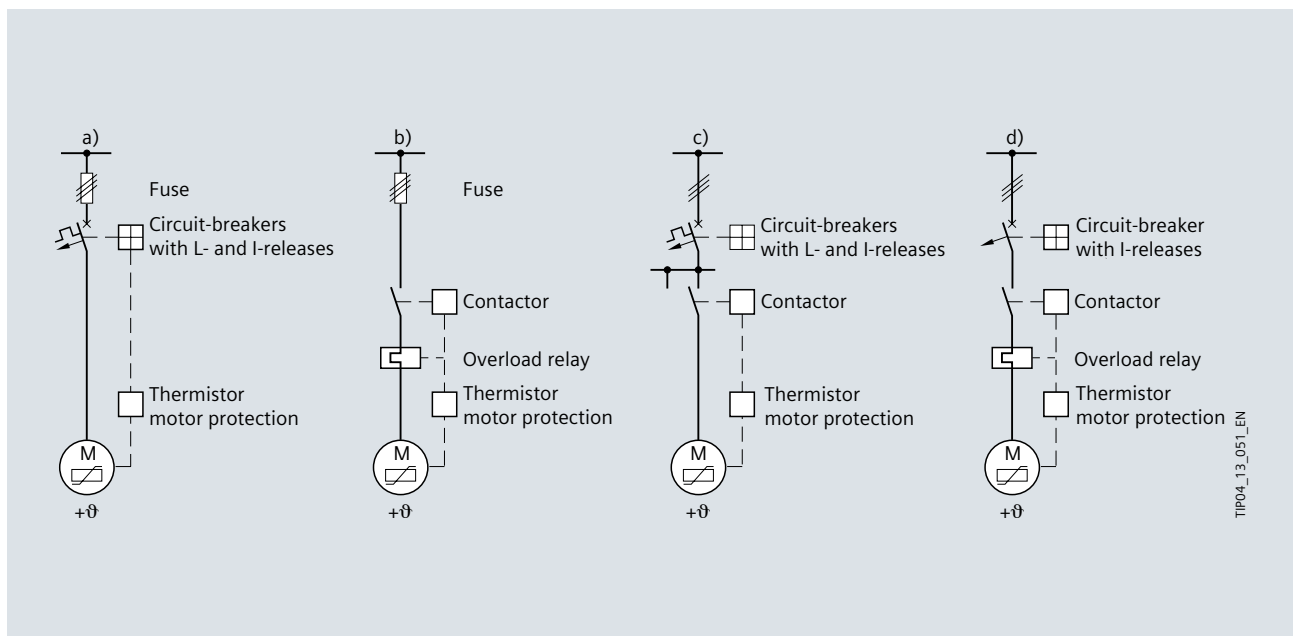

Fig. 7/10: Switchgear assembly comprising thermistor motor protection plus additional overload relay or release (schematic circuit diagram)

### 7.3.4 Selecting Protection Equipment

Branch circuits in distribution boards and control units can be provided with short-circuit protection by means of fuses or by means of circuit-breakers without fuses. The level of anticipated current limiting, which is higher in fuses with low rated currents than in current-limiting circuit-breakers with the same rated current, may also be a crucial factor in making a choice in favour of one or the other solution.

#### Comparing the protection characteristics of fuses with those of current-limiting circuit-breakers

The following should be taken into consideration when comparing the protection characteristics of fuses and circuit-breakers:

- The rated short-circuit breaking capacity, which can vary considerably
- The level of current limiting which is always higher with fuses of up to 400 A than for current-limiting circuit-breakers with the same rated current
- The shape of the prearcing time / current characteristics of fuses and the tripping characteristics of circuit-breakers
- The disconnection conditions acc. to IEC 60364-4-41 (VDE 0100-410)

#### Comparison of current-limiting characteristics of LV HRC fuses and circuit-breakers

Fig. 7/11 shows the current-limiting effect of a circuit-breaker (rated continuous current 63 A at 400 V, 50 Hz) compared to LV HRC fuses (type 3NA by Siemens, operational class gG, with rated currents 63 A and 100 A). Owing to the high motor starting currents, the rated current of the fuse must be higher than the rated operating current of the motor, this means a circuit-breaker with a minimum rated current of 63 A or a fuse with a minimum rated current of 100 A is required for a 30 kW motor.

#### Comparison between the tripping curves of fuses with those of circuit-breakers of the same current rating

The prearcing time / current characteristic curve a of the 63 A fuse-link, operational class gG, and the LI tripping curve "b" of a circuit-breaker are plotted in the time-current diagram in Fig. 7/12. The setting current for the inverse-time-delay overload release of the circuit-breaker corresponds to the rated current of the fuse-link.

In order to evaluate the different tripping performance in terms of their current dependence, three current ranges (marked with 1, 2, and 3 in Fig. 7/12) are distinguished:

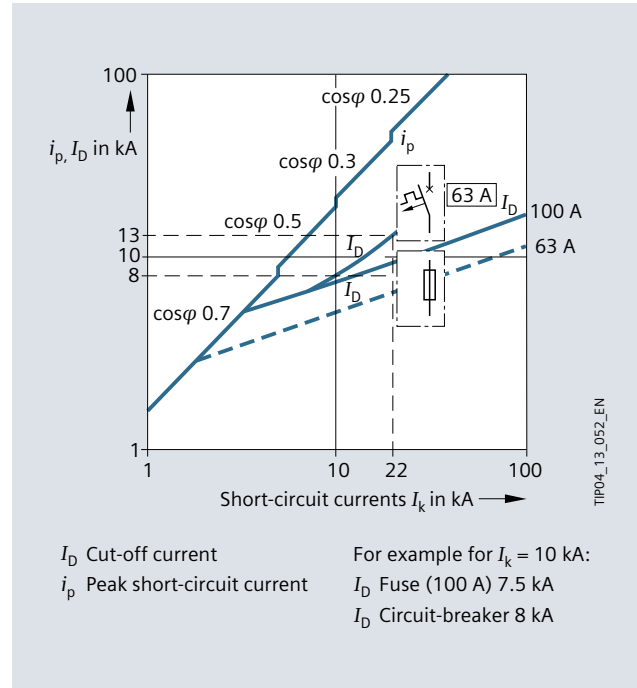

Fig. 7/11: Current-limiting characteristics of circuit-breaker (63 A) and LV HRC fuses (63 A or 100 A)

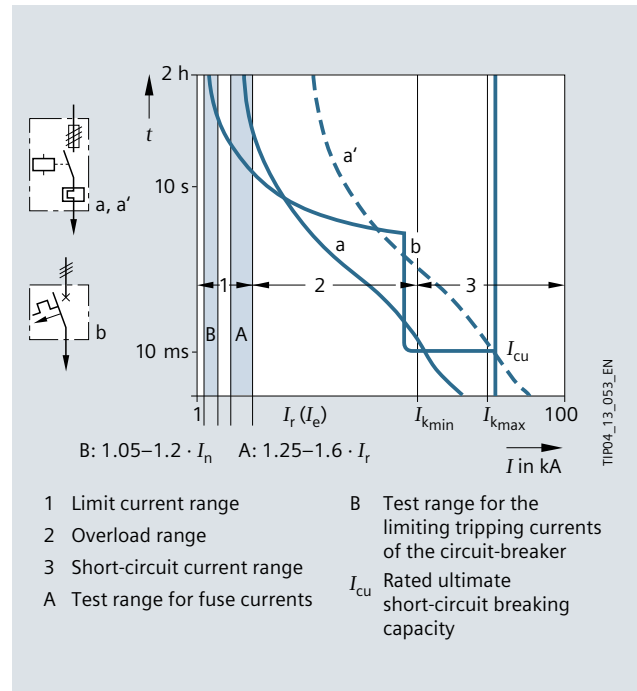

Fig. 7/12: Characteristic curves and rated switching capacities of a fuse (a) and circuit-breaker (b) with LI-releases

- Limit current range (1)  
The typical test range for fuse currents (A) is, for example, between 1.25 and 1.6 times the rated current while the test range for the limit tripping currents of the overload release (B) is between 1.05 and 1.2 times the current setting. The adjustable overload release allows for the current setting and, therefore, the limit tripping current to be matched more closely to the continuous current carrying capacity of the equipment to be protected than it would be possible with a fuse, whose current ratings are graded more widely, so that this would only permit approximate matching. Although the limit current of the fuse is adequate for providing overload protection of lines and cables, it is not sufficient for the starting current of motors, where a fuse with the characteristic a' would be needed
- Overload range (2)  
In the overload range (2), the prearcing time/current characteristic of the fuse is steeper than the tripping characteristic of the overload release. This is desired for the overload protection of cables and lines. For the overload protection of motors, however, the slow characteristic b is required
- Short-circuit current range (3)  
In the short-circuit current range (3), the instantaneous release of the circuit-breaker detects short-circuit currents above its operating value faster than the fuse. Higher currents are broken more quickly by the fuse. And for this reason, a fuse limits the short-circuit current more effectively than a circuit-breaker

This results in an extremely high rated breaking capacity for fuses of over 100 kA at an operating voltage of 690 V AC. As compared to this, the rated ultimate short-circuit breaking capacity  $I_{cu}$  depends on several factors, such as the rated operating voltage  $U_e$  and the type of construction.

A comparison between the protection characteristics of fuses, circuit-breakers, and their switchgear assemblies is compiled in [Tab. 7/7](#) and [Tab. 7/8](#).

## Selecting circuit-breakers for circuits with and without fuses

Circuits and control units can be designed with or without fuses.

### *Circuits with fuses (fuse-protected design)*

The standard design with fuses intended for system protection includes fuse-switch-disconnectors, switch-disconnectors with fuses, and fuse and base arrangements ([Tab. 7/9](#)).

The feed-in circuit-breaker provides overload protection and selective short-circuit protection for the transformer and distribution board. 3WL circuit-breakers are suitable for this purpose. A 3VA moulded-case circuit-breaker may also be used for transformers with lower rating, or a 3VL if selectivity is not required. The fuse for system protection protects the lines to the sub-distribution board against overloads and short circuits as well as those to non-motor consumers.

The switchgear assemblies comprising fuse and circuit-breaker, which provide motor protection, as well as fuses, contactor, and overload relay protect the motor feeder cable and the motor against overloads and short circuits.

### *Circuits without fuses (circuit-breaker protected design)*

In the case of distribution boards without fuses ([Tab. 7/10](#)), short-circuit protection is provided by circuit-breakers for system protection. In such configurations, circuit-breakers are also used as load switches, for motor protection only, or for starter assemblies together with the contactor. The protection ranges of the switchgear assemblies comprising circuit-breaker, contactor, and overload relay have already been dealt with. Further technical data can be found in the literature supplied by the manufacturer.



Characteristic	Fuse	Circuit-breaker
Rated switching capacity at alternating voltage	> 100 kA, 690 V	$f(I_r, U_e \text{ type}^{1)})$
Current limiting	$f(I_n, I_k)$	$f(I_r, I_k, U_e \text{ type}^{1)})$
Additional arcing space	None	$f(I_r, I_k, U_e \text{ type}^{1)})$
Clearly visible indication of operability	Yes	No
Operationally safe actuation	With expense <sup>2)</sup>	Yes
Remote switching	No	Yes
Automatic all-phase opening	With expense <sup>3)</sup>	Yes
Signalling option	With expense <sup>4)</sup>	Yes
Interlocking	No	Yes
Readiness for reclosing after: Disconnection on overload Disconnection on short circuit	No No	Yes $f(\text{condition})$
Service interruption	Yes	$f(\text{condition})$
Maintenance expense	No	$f(\text{no. of switching operations and condition})$
Selectivity	No expense	Extra expense required
Replaceability	Yes <sup>5)</sup>	if the same make
Short-circuit protection: Cable and line Motor	Very good Very good	Good Good
Overload protection: Cable and line Motor	Sufficient Not possible	Good Good

<sup>1)</sup> Type of construction may be: arc-quenching method, short-circuit strength owing to specific resistance, constructive design  
<sup>2)</sup> For example by means of shock-hazard protected fuse-switch-disconnectors with high-speed closing  
<sup>3)</sup> By means of fuse monitoring and dedicated circuit-breaker  
<sup>4)</sup> By means of fuse monitoring  
<sup>5)</sup> Because standardised

Tab. 7/7: Test range limits for the tripping performance of protection equipment (f(...) denotes a functional dependence of the characteristic from the quantities and parameters in brackets)

[back to page 124](#)

Protection devices with fuses							
Protected items and switching frequency	Fuse						
	Circuit-breaker						
	Contactor						
	Overload protection						
	Thermistor motor protection						
	Overload protection						
– Cable and line	++	++	+	+	++	++	
– Motors (with thermally critical stators)	++ <sup>1)</sup>	++	++	++	++	++	
– Motors (with thermally critical rotors)	++ <sup>1)</sup>	++	+	+	++	++	
Short-circuit protection							
– Cable and line	++	++	++	++	++	++	
– Motor	++	++	++	++	++	++	
Switching frequency	–	++	–	++	–	++	
Protection devices without fuses							
Protected items and switching frequency	–						
	Circuit-breaker						
	Contactor						
	Overload protection						
	Thermistor / SIMOCODE motor protection						
	Overload protection						
– Cable and line	++	++	++	++	++	+	
– Motors (with thermally critical stators)	++ <sup>1)</sup>	++	++	++	++ <sup>1)</sup>	++	
– Motors (with thermally critical rotors)	++ <sup>1)</sup>	++	++	++	++ <sup>1)</sup>	++	
Short-circuit protection							
– Cable and line	++	++	++	++	++	++	
– Motor	++	++	++	++	++	++	
Switching frequency	+	+	+	+	–	–	

<sup>1)</sup> Protection with minor restriction in the event of a line failure ++ very good + good – minor

Tab. 7/8: Comparison between the protection characteristics of different switchgear assemblies (schematic circuit diagrams) back to page 124

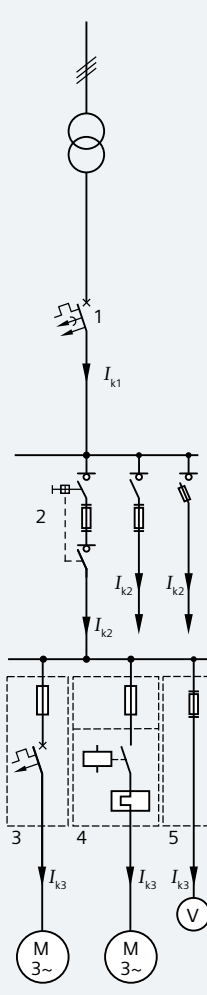

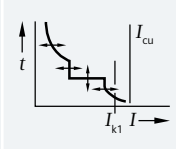
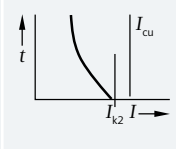
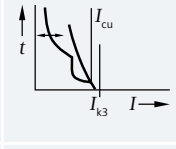
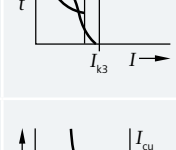
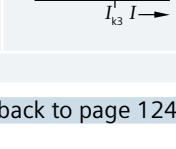
No.	Type of circuit-breaker	Rated ultimate short-circuit breaking capacity $I_{cu}$	Type of release or relay					Fuse	Tripping characteristic <sup>1)</sup>
			L Adjustable	L Fixed setting	S Adjustable	I Fixed setting	I Adjustable		
<b>Feed-in circuit-breaker</b>									
1	Circuit-breaker for system protection with selectivity requirement	$\geq I_{k1}$	x	-	x	-	x		
<b>Distribution circuit-breaker</b>									
2	Fuse for system protection	$\geq I_{k2}$	-	-	-	-	-	x	
<b>Load circuit-breaker</b>									
3	Fuse and circuit-breaker for motor protection	$\geq I_{k3}$ $\leq I_{k3}$	- x	-	-	-	x	-	
4	Fuse and direct on-line starter for motor protection	$\geq I_{k3}$ $\leq I_{k3}$	- x	-	-	-	-	x	
5	Fuse for power consumer	$\geq I_{k3}$	-	-	-	-	-	x	

<sup>1)</sup>  $\updownarrow \leftrightarrow$  Adjustable release

Tab. 7/9: Distribution boards combining fuses and circuit-breakers

[back to page 124](#)

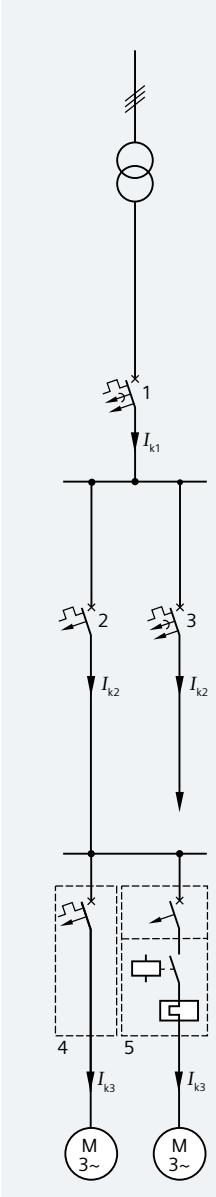

No.	Type of circuit-breaker	Rated ultimate short-circuit breaking capacity $I_{cu}$	Type of release or relay					Tripping characteristic <sup>1)</sup>
			L Adjustable	L Fixed setting	S Adjustable	— Fixed setting	— Adjustable	
<b>Feed-in circuit-breaker</b>								
1	Circuit-breaker for system protection with selectivity requirement	$\geq I_{k1}$	x	—	x	—	x	
<b>Distribution circuit-breaker</b>								
2 <sup>2)</sup>	Circuit-breaker for system protection without selectivity requirement	$\geq I_{k2}$	—	x	—	x	—	
3	Circuit-breaker for system protection with selectivity requirement	$\geq I_{k2}$	x	—	x	—	x	
<b>Load circuit-breaker</b>								
4	Circuit-breaker for motor protection	$\geq I_{k3}$	x	—	—	x	—	
5	Circuit-breaker and direct on-line starter for motor protection	$\geq I_{k3}$ $\geq I_{k3}$	—	—	—	x	—	

1)  $\updownarrow \leftrightarrow$  Adjustable release  
2) 3 Variants possible, variant 3 depicted

Tab. 7/10: Power distribution with circuit-breaker without fuse

[back to page 124](#)

## 7.4 Miniature Circuit-breaker

Miniature circuit-breakers (MCBs) are mainly designed for the protection of cables and lines against overload and short circuit, thus ensuring the protection of electrical equipment against excessively high heating in compliance with the relevant standards, for example IEC 60364-4-43 (VDE 0100-430). Under certain conditions, MCBs in a TN system also provide protection against electric shock at excessively high contact voltage due to wrong insulation, e.g. according to IEC 60364-4-41 (VDE 0100-410).

Miniature circuit-breakers are used in distribution networks, both for commercial buildings and industrial buildings. Due to a wide range of versions and accessories (for example auxiliary contacts, fault signal contacts, shunt trips etc.), they are able to meet the various requirements of the most diverse areas of application.

### Tripping characteristics

Four tripping characteristics (A, B, C, and D) are available for any kind of application; they correspond to the equipment being connected in the circuit to be protected.

- Tripping characteristic A is particularly suitable for the protection of transducers in measuring circuits, for circuits with electronic control and where disconnection within 0.4 s is required in accordance with IEC 60364-4-41 (VDE 0100-410)
- Tripping characteristic B in accordance with IEC 60898-1 (VDE 0641-11) is the standard characteristic for socket circuits in residential and commercial buildings
- Tripping characteristic C in accordance with IEC 60898-1 (VDE 0641-11) has advantages when used with equipment with higher inrush currents such as luminaires and motors
- Tripping characteristic D in accordance with IEC 60898-1 (VDE 0641-11) is adapted to intensely pulse-generating equipment such as transformers, solenoid valves or capacitors

### Operating method

Miniature circuit-breakers are manually operated protection switches providing remote overcurrent tripping (instantaneous thermal overcurrent release). Multi-phase devices are coupled mechanically at the outside through the handles and also inside through their releases.

### Standards

International basic standards are IEC 60898-1 and IEC 60898-2. In Germany, the national standards VDE 0641-11 and VDE 0641-12 are based on them. The sizes are described in DIN 43880. Regarding personal

safety, the relevant standards, for example concerning fault clearing requirements in accordance with IEC 60364-4-41 (VDE 0100-410), have to be met.

### Versions

MCBs are available in many different versions: 1-phase, 2-phase, 3-phase, and 4-phase as well as with switched neutral conductor 1-phase+N and 3-phase+N.

Depending on the device type, the following items can be retrofitted:

- Auxiliary switch (AS)
- Fault-signal contact (FC)
- Shunt trip (ST)
- Undervoltage release (UR)
- Residual current protection device (RCD)

By fitting an RCD to an MCB, an RCBO assembly is created. As a complete system, it can be used for cable and line protection as well as for protection against personal injury in the event of direct or indirect contact voltages. Special arc-fault detection units, for example from the 5SM6 series, identify operational and dangerous arc faults, which enables reliable circuit disconnection when a dangerous arc fault occurs. These arc-fault detection units are also available in versions which are combined with MCBs and RCBOs.

Auxiliary switches (AS) signal the switching state of the MCB and indicate whether it has been switched off manually or automatically. Fault-signal contacts (FC) indicate tripping of the MCB due to overload or short circuit. Open-circuit shunt releases (ST) are suitable for remote switching of MCBs. Undervoltage releases protect devices connected in the circuit against impacts of insufficiently low supply voltage.

By connecting the AS and the FC to an instabus KNX binary input, the signals may also be read into an *instabus* KNX system (for example GAMMA *instabus*). When using an *instabus* KNX binary output, the MCB, which is tripped via the shunt trip, can also be remotely tripped via *instabus* KNX.

Depending on the device type, miniature circuit-breakers by Siemens have the following features:

- Very good current-limiting performance
- Identical terminals on both sides for optional feeding from the top or bottom
- Installation and dismantling without the use of tools
- Rapid and easy removal from the system
- Terminals safe-to-touch by fingers or the back of the hand in accordance with EN 50274 (VDE 0660-514)

- Combined terminals for simultaneous connection of busbars and feeder cables
- Main switch quality in accordance with IEC 60204-1 (VDE 0113-1)
- Separate switch position indicator

Alternating-current type MCBs are suitable for all AC and 3-phase networks up to a nominal voltage of 240/415 V and all DC networks up to 60 V (1-phase) and 120 V (2-phase). The MCB voltage rating is 230/400 V AC. AC/DC current type MCBs may also be used for 220 V DC (1-phase) and 440 V DC (2-phase). In order to avoid damaging of the conductor insulation in case of faults, temperatures must not rise above certain values. For PVC insulation, these values are 70 °C permanently or 160°C for a maximum of 5 s (short circuit).

For line-overcurrent protection, the MCBs usually have two independent releases. In the event of overload, a bimetal contact opens inverse-time-delayed corresponding to the

current value. If a certain threshold is exceeded in the event of a short circuit, however, an electromagnetic overcurrent release instantaneously trips. The tripping range (time-current threshold zone) of the MCBs, following IEC 60898-1 (VDE 0641-11) is determined by the parameters  $I_1$  to  $I_5$  (see Fig. 7/13). Parameters  $I_B$  and  $I_Z$  of the line are correlated to the above.

The tripping conditions of the MCBs for characteristics B, C, and D from the IEC 60898-1 (VDE 0641-11) standard facilitate assigning them to conductor cross sections. In the relevant standards, for example IEC 60364-4-43 (VDE 0100-430), the following conditions are listed:

*Rated current rule*

$$I_B \leq I_n \leq I_Z$$

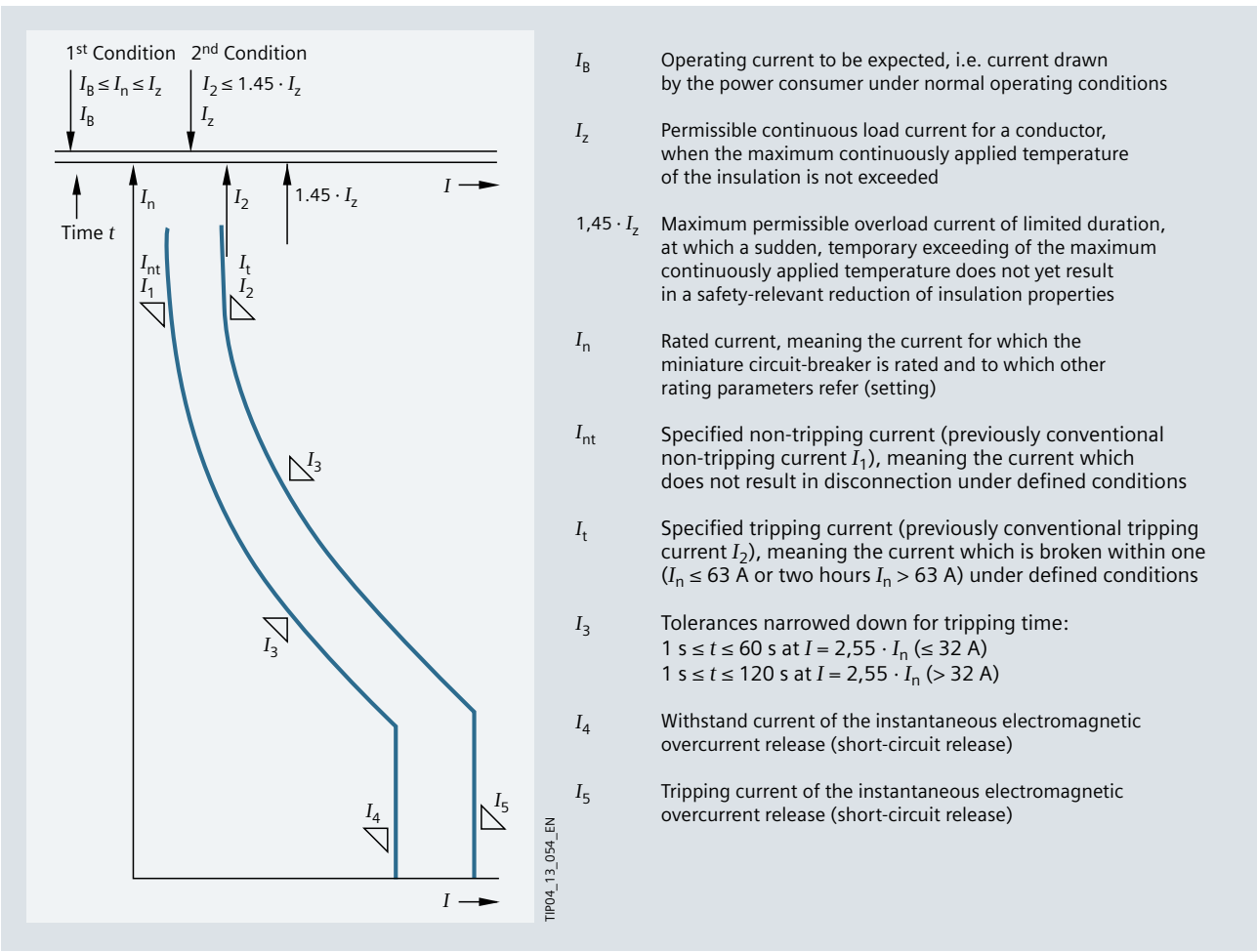

Fig. 7/13: Schematic reference value diagram of lines and their protection devices

### Tripping current rule

$$I_2 \leq 1.45 \cdot I_z$$

Since the tripping current rule is automatically fulfilled because of  $I_2 = 1.45 \cdot I_z$ , it suffices for the analysis of MCB characteristics if the rated current  $I_n$  of the MCB is less or equal to the conductor's permissible continuous load current  $I_z$ .

Resulting from this, an assignment of rated currents for MCBs to conductor cross sections can be given (Tab. 7/11), related to an ambient temperature of +30°C, as it is considered appropriate in IEC 60364-4-43 (VDE 0100-430), and in relation to the type of installation and accumulation of equipment.

*Example: flat-webbed cable, stranded cable, on or in the wall, installation type C<sup>1</sup> at +30°C ambient temperature*

Siemens MCBs are available with the tripping characteristics B, C, and D, bearing, inter alia, the VDE mark based upon the CCA procedure (CENELEC Certification Agreement).

All tripping characteristics are depicted in Fig. 7/14. Due to the position of the tripping bands, the following applies from curve A to D:

- Current pulse withstand strength rises
- Permissible line and cable length for the protection of persons decreases

<sup>1</sup> Installation type C in accordance with EC 60364-5-52 (VDE 0298-4): cables are fixed in such a way that the spacing between them and the wall surface is less than 0.3 times the outer cable diameter.

Rated cross section $q_n$ in mm <sup>2</sup>	Rated MCB current $I_n$ for protection of		$I_z$ (line) permissible continuous load current in case of	
	2 conductors under load in A	3 conductors under load in A	2 conductors under load in A	3 conductors under load in A
1.5	16	16	19.5	17.5
2.5	25	20	27	24
4	32	32	36	32
6	40	40	46	41
10	63	50	63	57
16	80	63	85	76
25	100	80	112	96
35	125	100	138	119

Tab. 7/11: MCB and conductor cross section matrix

### Temperature impact

The tripping characteristics are standard defined at an ambient temperature of +30°C. At higher temperatures, the thermal tripping curve in Fig. 7/14 shifts to the left and to the right at lower temperatures. This means that tripping becomes effective even with lower currents present (higher temperatures) or only with higher currents (lower temperatures).

This has to be taken into account in particular for an installation in hot rooms, in encapsulated distribution boards where, owing to the current-induced heat losses of the built-in devices, higher temperatures may prevail and for distribution boards installed outdoors. MCBs can be used at temperatures ranging from -25°C to +55°C. The relative humidity may be 95%.

### Resistance to climate

Siemens miniature circuit-breakers are resistant to climate in accordance with IEC 60068-2-30. They were successfully tested in six climatic cycles.

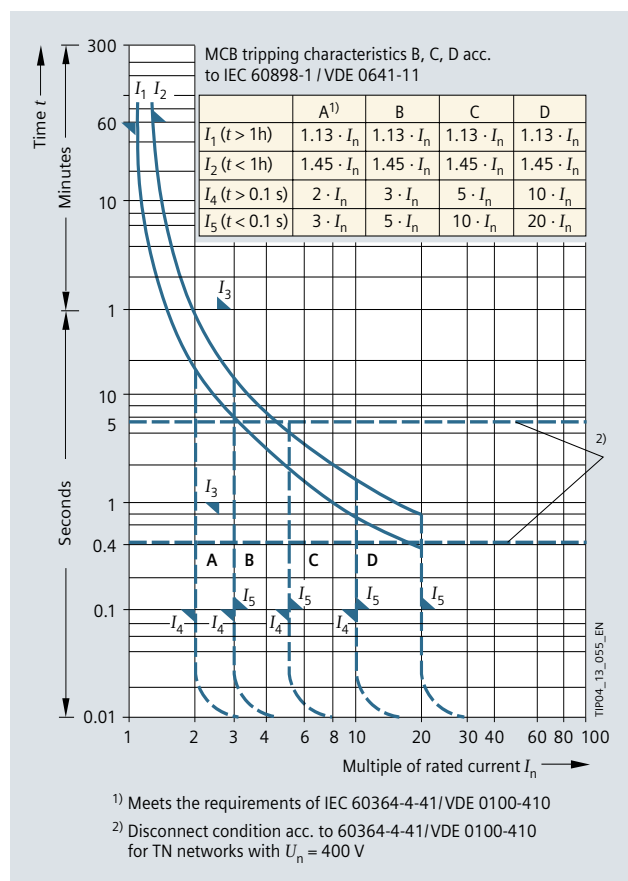

Fig. 7/14: Time-current limit ranges of MCBs

### Degree of protection

As MCBs are mainly installed in distribution boards, their degree of protection must meet the requirements of the respective type of environment. MCBs without an encapsulation can reach IP30 according to IEC 60529 (VDE 0470-1) provided that they have adequate terminal covers. MCBs can be equipped with a snap-on fixing for rapid fitting on 35-mm wide standard mounting rails. Some versions may additionally be screwed on mounting plates.

### Installation

Moreover, some type series are available with a rapid wiring system for manual handling without the use of tools, which even enables the removal of individual MCBs from the busbar system.

### Rated switching capacity $I_{cn}$

Besides a reliable adherence to characteristic curves, an important performance feature of MCBs is their rated switching capacity. On the basis of IEC 60898-1 (VDE 0641-11), it is divided into switching capacity classes and indicates up to which level short-circuit currents can be broken. Standard values for the rated short-circuit breaking capacity are 1,500 A, 3,000 A, 4,500 A, 6,000 A, 10,000 A, 15,000 A, 20,000 A, and 25,000 A. Siemens MCBs provide rated switching capacity values up to 25,000 A with VDE approval, dependent on the version.

### Current limiting classes

In order to obtain information about the selectivity of MCBs to line-side fuses, current limiting can be considered according to the  $I^2t$  characteristic. Tab. 7/12 lists the  $I^2t$  values of current limiting class 3 for type B and C miniature circuit-breakers up to a rated current of 63 A which are permitted in the European region. The basis is change A13 of the EN 60898-1 (VDE 0641-11) standard. IEC 60898-1

does not mention a current limiting class and only refers to the  $I^2t$  characteristic to describe the MCB in general terms.

In Germany, the Technical Supply Conditions (TAB) of the German distribution system operators (DSO) apply. TAB stipulates for residential and commercial buildings that only class 3 MCBs with a rated switching capacity of at least 6,000 A be used in distribution boards connected downstream of the electricity meter, since the service entrance fuse per residential unit is always  $\leq 63$  A, thus ensuring back-up protection.

Devices must be labelled 

6000
3

.

### Selectivity

Selectivity means that only that protection device will trip in the event of a fault which is closest to the fault location in the current path. This way the energy flow can be maintained in circuits which are connected in parallel. In Fig. 7/15, the current curve in a disconnection process is shown schematically with regard to current-limiting classes. Siemens MCBs of type B16 reduce the energy flow to much lower values than defined for current limiting class 3. Fig. 7/15 shows the selectivity limits of MCBs with different current limiting classes as the intersection of the MCB tripping curve with the prearcing characteristic of the fuse. The highly effective current limitation of the MCB can also be noted as a better selectivity towards the line-side fuse.

### Back-up protection

If the short-circuit current exceeds the rated MCB switching capacity at the point where the MCB is installed, another short-circuit protecting device has to be connected upstream. Without impairing the operability of the breaker in such cases, the switching capacity of such an assembly will be increased up to 50 kA.

In some countries, circuit-breakers rather than LV HRC fuses are increasingly connected upstream, which – depending

Rated short-circuit breaking capacity in A	$\leq 16$ A		20, 25, 32 A		40 A		50, 63 A	
	Type B	Type C	Type B	Type C	Type B	Type C	Type B	Type C
3,000	15,000	17,000	18,000	20,000	21,600	24,000	28,000	30,000
4,500	25,000	28,000	32,000	37,000	38,400	45,000	48,000	55,000
6,000	35,000	40,000	45,000	52,000	54,000	63,000	65,000	75,000
10,000	70,000	80,000	90,000	100,000	108,000	120,000	135,000	145,000

Tab. 7/12: According to EN 60898-1/A13 (VDE 0641-11/A13): permissible  $I^2t$ -(let-through) values of current limiting class 3 (in A<sup>2</sup>s) for MCBs type B and C up to 63 A



on the type – reduces the combined switching capacity considerably. Although circuit-breakers have a high inherent rated breaking capacity, they still do not switch sufficiently current-limiting in the range of the MCB switching capacity limit (6 kA/10 kA) so that they can provide less support in relation to a fuse.

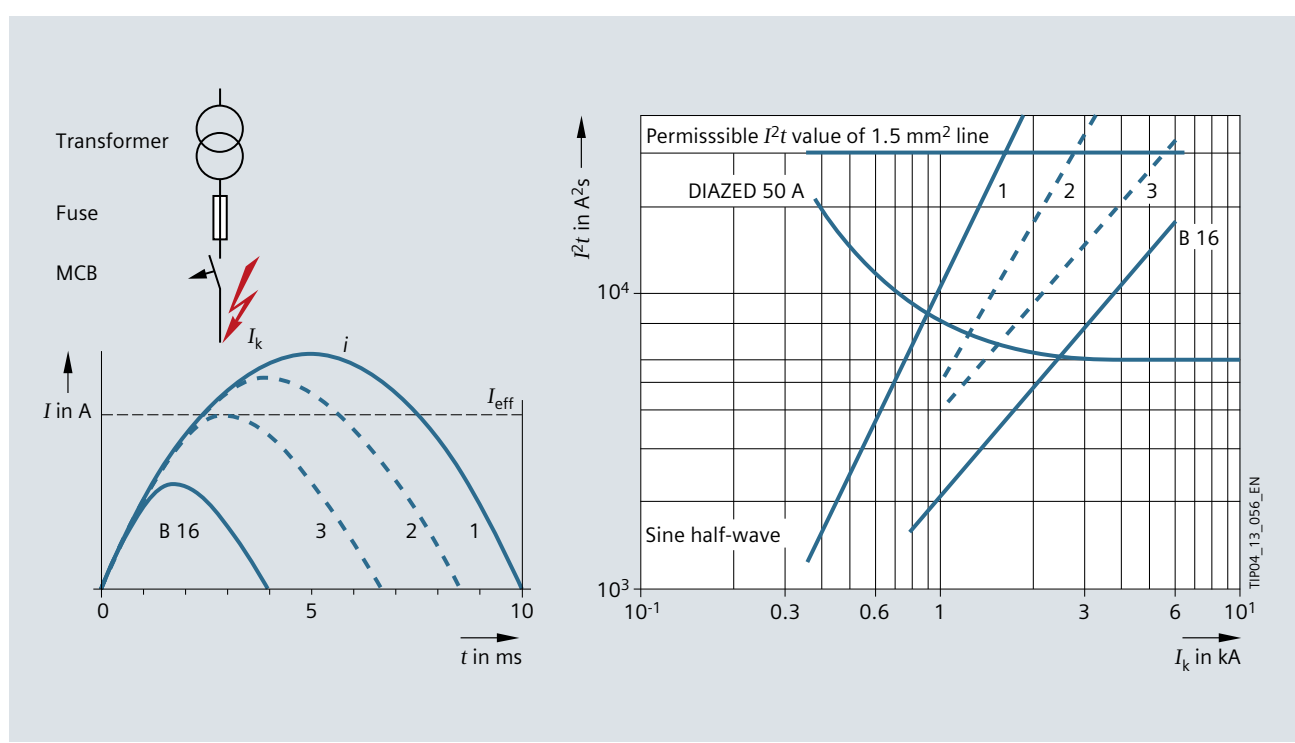

Fig. 7/15: Selectivity of MCBs in current limiting classes 1, 2, and 3 towards back-up fuses (curve B16 applies to Siemens model 16 A, tripping characteristic B) back to page 132

## 7.5 Selectivity in Low-Voltage Grids

Some descriptive standards about setting up low-voltage installations, in particular IEC 60364-7-710 (VDE 100-710) and IEC 60364-7-718 (VDE 0100-718) ask for proof of selectivity. Full selectivity is achieved with series-connected protection devices if only the device in the immediate vicinity upstream of the fault location disconnects from supply.

A distinction is made between two types of selectivity:

- Partial selectivity according to IEC 60947-2 (VDE 0660-101):  
If there are two series-connected overcurrent protection devices, the load-side protection device protects up to a given overcurrent value by overcurrent discrimination without the other protection device being active
- Full selectivity according to IEC 60947-2 (VDE 0660-101):  
Overcurrent discrimination of two series-connected overcurrent protection devices, where the load-side protection device protects up to the maximum short-circuit current present there without the other protection device being active

### Selectivity types

- Current selectivity (current discrimination):  
Selective current breaking capacity by grading the instantaneous short-circuit releases ( $I_i$  releases)
- Time selectivity:  
Grading of the adjustable tripping times ( $t_{sd}$  in the S-part) of the short-circuit releases This applies to standard as well as to current-dependent characteristics. Regarding circuit-breakers with LSI characteristic, time selectivity is frequently used in main distribution boards and at interfaces between devices of different manufacturers
- Dynamic/energy selectivity  
Selectivity based on the evaluation of the let-through energy or respectively, the cut-off current, of the downstream device and the tripping energy or tripping current of the upstream protection device.

### Determining the selectivity type

As a rule, the selective behaviour of two series-connected protection devices can be determined in one of the two ways:

- Comparing characteristic curves (with reservations, as demonstrated below)
- Experimental selectivity measurement (alternatively, a complex simulation of the selectivity conditions – a so-called "desk study" in accordance with IEC 60947-2 Edition 4.2, 2013 – can be performed)

### Comparing characteristic curves

Three diagram types can be used for comparing characteristic curves:

- Time-current diagram
- Cut-off current diagram
- Let-through energy diagram

Since these characteristic curves are compared over several orders of magnitude, they are traditionally plotted on log-log paper. In the overload range, operating and total clearance times are approximately the same and can be plotted on one time-current diagram.

Selectivity in the event of a short circuit can be evaluated for the time range  $\geq 100$  ms by comparing characteristic curves in the L or respectively the S section. Among other things, tolerances, required protection settings, and a scaled plotting of the curves must be observed.

For the time range shorter than 100 ms, selectivity must be verified by testing or by a so-called "desk study" (see IEC 60947-2 Edition 4.2, 2013). In a "desk study", a complex simulation is performed which considers the dynamic response of the switching devices with the corresponding let-through and operating energies, respectively currents. Due to the fact that the time and cost expense involved in testing or a desk study is usually very high if different devices are used in the power distribution system, selectivity limits can often be obtained from renowned equipment manufacturers only. Then, the respective cut-off currents or let-through energies can be compared to the operating currents, respectively the let-through energies, of the protection devices in practice. The prerequisite being that the relevant data is available from the equipment manufacturer and that it is analysed thoroughly. For the reasons given above, a selectivity evaluation requires the strict use of products by one manufacturer only.

All characteristic curves must – if not already specified by the manufacturer – be assigned a tolerance band to ensure dependable selectivity determination. IEC 60947-2 (VDE 0660-101) requires for switching devices that a tolerance of  $\pm 20\%$  be allowed for the instantaneous overcurrent release. The operating times, which are sometimes considerably shorter at normal operating temperatures, must be considered for electromechanical overload releases.

### Determination of the selectivity limit

As a rule, all selectivity limits between two protection devices can be determined by carrying out measurements or tests. These measurements are virtually indispensable, particularly when assessing selectivity in the event of a short circuit, owing to the extremely rapid switching operations when current-limiting protection equipment is used. The measurements can, however, be very costly and complicated, which is why many manufacturers publish selectivity tables for their switchgear. If SIMARIS design is used, the software automatically takes all these criteria for Siemens products into account.

An approximation of minimum selectivity limits for switchgear assemblies can be performed as follows:

- With supply-side circuit-breaker by comparing the cut-off current characteristic of the nearest load-side device with the operating value of the instantaneous short-circuit release for the line-side device
- With upstream fuse Selectivity prevails, as long as the let-through energy of the downstream protection device does not exceed the prearcing energy of the fuse

## 7.5.1 Selectivity in Radial Networks

### Selectivity between series-connected fuses

The feeding line and the outgoing circuits branching from the busbar of a distribution board carry different operating currents and, therefore, also have different cross sections. Consequently, they are usually protected by fuses with different rated currents, which ensure selectivity on account of their different response behaviours.

- Selectivity between series-connected fuses with identical operational class:

When fuses of the operational class gG or gL are used, selectivity is generally ensured across the entire overcurrent range up to the rated switching capacity (full selectivity) if the rated currents differ by a factor of 1.6 or higher (Fig. 7/16). When grading rating currents in the ratio 1:1.6, a comparison of characteristics in the

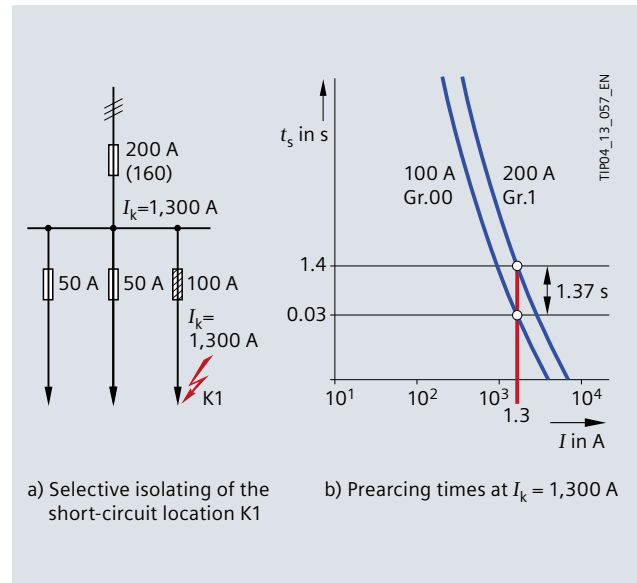

Fig. 7/16: Selectivity between series-connected LV HRC fuses with identical operational classes (example)

time-current diagram can be omitted for fuses of the same operational class

- Selectivity between series-connected fuses with different operational classes: Since the shape of the time-current characteristics differ for different operational classes (for example aM and gG) a comparison of characteristics is necessary. The associated data must be provided by the manufacturer. For LV HRC fuses by Siemens the data for computer-based selectivity determination is integrated in SIMARIS design

The Joule integral ( $I^2t$  values) should be compared in the case of high short-circuit currents. In the example shown in Fig. 7/16, an LV HRC fuse with 160 A would also be fully selective towards a fuse with 100 A.

### Selectivity between series-connected circuit-breakers

The different releases of circuit-breakers allow to attain selectivity by proceeding in different ways when grading:

- Current selectivity
- Dynamic selectivity (energy selectivity)
- Time selectivity
- Time-reduced selectivity control for zone-selective interlocking (ZSI)

The different selectivity evaluations shall be dealt with briefly below.

*Current selectivity (grading the operating currents of I-releases)*

Selectivity can be achieved by grading the operating currents of I-releases (Fig. 7/17).

Prerequisites for this are:

- Current grading with different short-circuit currents  
The short-circuit currents are sufficiently different in the event of a short circuit at the respective mounting locations of the circuit-breakers
- Current grading with differently set I-releases  
The rated currents and, therefore, the I-release values of the upstream and downstream circuit-breakers differ accordingly
- 5-second disconnect and line-protection conditions  
In consideration of the 5-second disconnect condition specified in IEC 60364-4-41 (VDE 0100-410) or the 5-second line-protection condition specified in IEC 60364-4-43 (VDE 0100-430) (if line protection cannot be provided in any other way), the I-release must gener-

ally be set to less than  $I_{kmin} - 20\%$  so that even very small short circuits are cleared at the input terminals of the downstream circuit-breaker Q1 within the required time

Only partial selectivity can be established by comparing characteristic curves for current grading, since the curve in the range  $< 100\text{ ms}$  – which is frequently, and quite rightly represented by broken lines – owing to the complicated dynamic switching and tripping operations, does not permit any conclusions with regard to selectivity.

*Selectivity through circuit-breaker coordination (dynamic selectivity)*

With high-speed processes, for example in the event of a short circuit, and the interaction of series-connected protection devices, the dynamic processes in the circuit and in the electromechanical releases have a considerable effect on selectivity behaviour, particularly if current limiters are used. Selectivity is also achieved if the downstream current-limiting protection device disconnects so quickly that, although the cut-off current does momentarily exceed the operating value of the upstream protection device, the

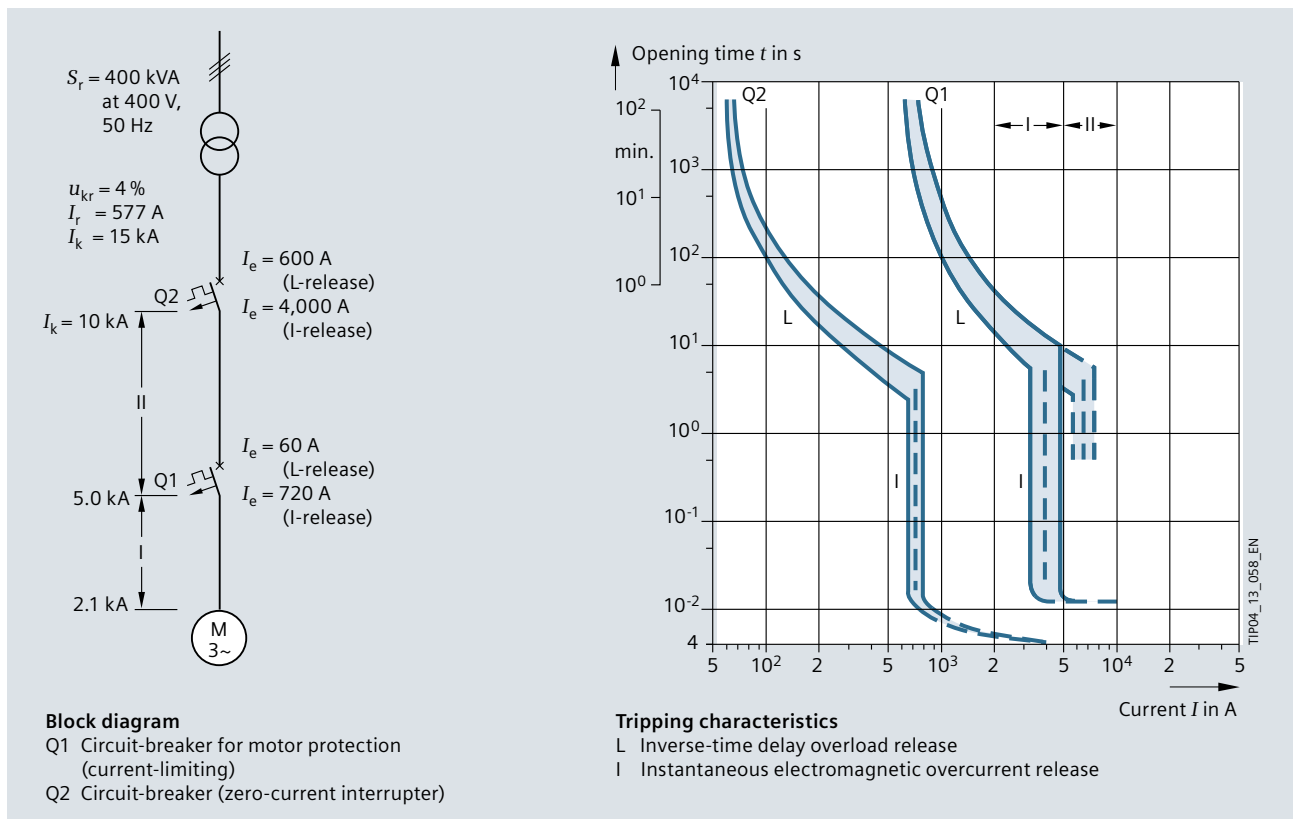

Fig. 7/17: Current selectivity for two series-connected circuit-breakers at different short-circuit current levels (example)

“mechanically slow” release does not have time to unlatch. The cut-off current is dependent on the prospective short-circuit current (maximum solid short-circuit current to be expected) and the current limiting properties.

*Selectivity limits of two series-connected circuit-breakers*

A maximum short-circuit value – the selectivity limit – up to which the downstream circuit-breaker can open more quickly and alone, i.e. selectively, can be determined for each switchgear assembly. The selectivity limit may be well above the operating value of the instantaneous overcurrent release in the upstream circuit-breaker (see Fig. 7/17). Irrespective of this, it is important to verify selectivity in the event of an overload by comparing the characteristic curves and to verify that tripping times are in accordance with the relevant regulations.

Generally speaking, dynamic selectivity in a short circuit only provides partial selectivity. This may be sufficient (full selectivity) if the prospective maximum short-circuit current at the location of the downstream protection device is lower than the established selectivity limit. In case of current grading involving partial selectivity, as it frequently results from the disconnect condition, it is often a good possibility to verify full selectivity by considering the dynamic selectivity without having to use switching devices with short-time delay overcurrent releases.

*Selectivity by means of short-time-delay overcurrent releases (time grading)*

If current grading is not possible and cannot be achieved by selecting the switchgear in accordance with selectivity tables (dynamic selectivity), selectivity can be provided by time-grading short-time-delay overcurrent releases. This requires grading of both the tripping delays and the appropriate operating currents.

*Time grading with virtually identical short-circuit currents*

The upstream circuit-breaker is equipped with short-time-delay overcurrent releases (S) so that, if a fault occurs, only the downstream circuit-breaker disconnects the affected part of the installation from the system. Time grading can be implemented to safeguard selectivity if the prospective short-circuit currents are almost identical. This requires grading of both the tripping delays and the operating currents of the overcurrent releases.

The example of Fig. 7/18 shows the block diagram with four series-connected circuit-breakers and the associated grading times for selective short-circuit protection. The necessary grading time, which allows for all tolerances, depends on the operating principle of the release and the type of circuit-breaker.

*Electronic S-releases*

With electronic short-time-delay overcurrent trip units (S-releases), a grading time of approximately 70 ms to 100 ms from circuit-breaker to circuit-breaker is sufficient to allow for all tolerances. The operating current of the short-time-delay overcurrent trip unit should be set to at least 1.45 times (twice per 20% tolerance, unless other values are specified by the manufacturer) the value of the downstream circuit-breaker.

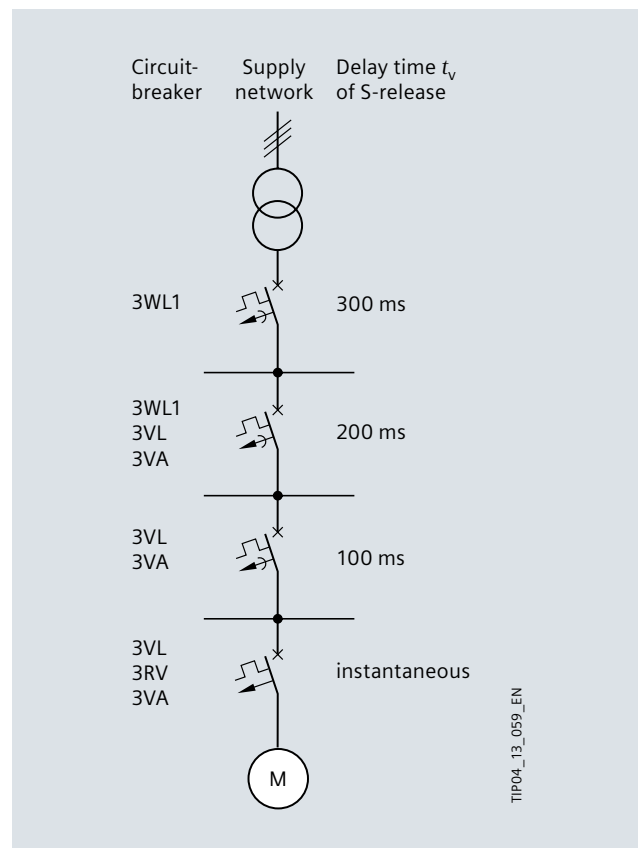

**Fig. 7/18:** Required delay time settings for electromagnetic short-time-delay S-releases for selective short-circuit protection

### Additional I-releases

In order to reduce the short-circuit stress in the event of a "dead" short circuit at the circuit-breaker, the upstream circuit-breakers can be fitted with instantaneous electromagnetic overcurrent releases in addition to the short-time delay overcurrent releases (Fig. 7/19). The value selected for the operating current of the instantaneous electromagnetic overcurrent releases must be high enough to ensure that the releases only operate in case of direct "dead" short circuits and, under normal operating conditions, do not interfere with selective grading.

### Zone-selective interlocking (ZSI)

A microprocessor-controlled short-time grading control, also called zone-selective interlocking (ZSI), has been developed for circuit-breakers to prevent excessively long tripping times when several circuit-breakers are connected in series. This control function allows the tripping delay to be reduced to 50 ms (maximum) for the circuit-breakers upstream of the short circuit location. The functioning principle of ZSI is represented in Fig. 7/20.

A short circuit at K1 is detected by Q1, Q3, and Q5. If ZSI is active, Q3 is temporarily disabled by Q1 and Q5 by Q3 by

means of appropriate communication lines. Since Q1 does not receive any disabling signal, the I-release associated with the "virtual" tripping time  $t_i$ , already trips after 10 ms.

A short circuit at K2 is only detected by Q5; since it does not receive any disabling signal, it trips after 50 ms. Without ZSI, breakers would only trip after 200 ms.

### Selectivity between circuit-breaker and fuse

When considering selectivity in conjunction with fuses, a permissible tolerance of  $\pm 10\%$  in the direction of current flow must be allowed for in the time-current characteristics.

### Circuit-breaker with downstream fuse

#### Selectivity between LI-releases and fuses with very low rated currents

In the overload range up to the operating current  $I_i$  of the instantaneous overcurrent release, partial selectivity is achieved if the upper tolerance band of the characteristic fuse curve does not touch the tripping curve of the fully preloaded, thermally delayed overload release (L).

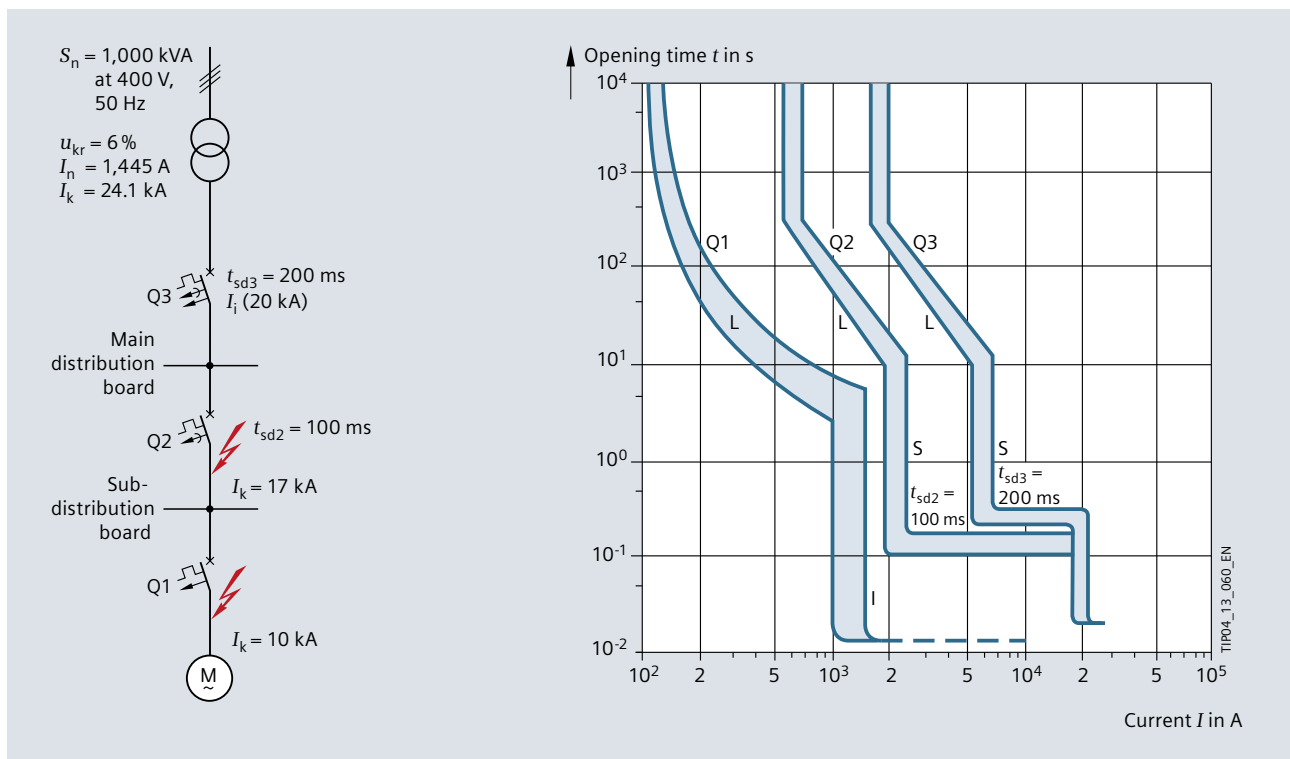

Fig. 7/19: Selectivity between three series-connected circuit-breakers with limitation of short-circuit stress by means of an additional I-release in circuit-breaker Q3

When the circuit-breakers work at "operating temperature", a reduction of the tripping time of up to 25% must be considered unless specified otherwise by the manufacturer.

Full selectivity is given using circuit-breakers without short-time-delay overcurrent releases (S-releases) if the cut-off current  $I_D$  of the fuse does not reach the operating current of the instantaneous overcurrent release. This is, however, only to be expected for a fuse, the rated current of which is very low compared to the rated continuous current of the circuit-breaker (Fig. 7/21).

*Selectivity between LS-releases and fuses with relatively high rated currents*

Due to the dynamic processes that take place in electromagnetic releases, full selectivity can also be achieved with fuses, whose  $I_D$  briefly exceeds the operating current of the release. Once again, a reliable statement about selectivity can only be made by means of measurements or complex simulations.

Full selectivity can be achieved by using circuit-breakers with short-time-delay overcurrent releases (S-releases) if

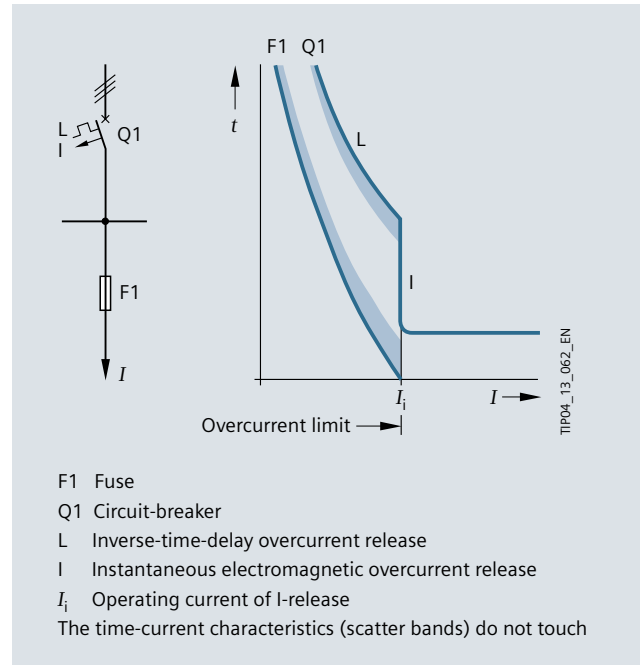

Fig. 7/21: Selectivity between circuit-breaker and downstream fuse in the overload range

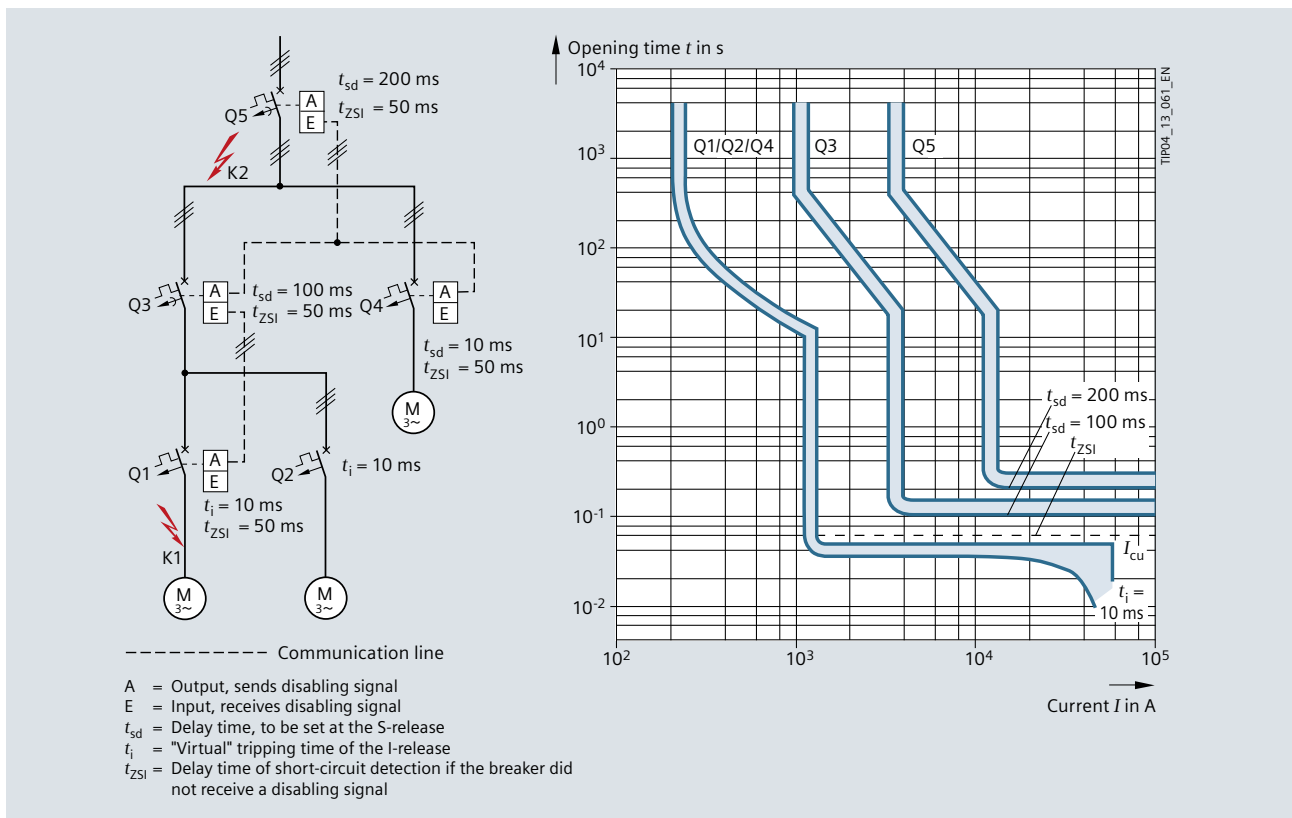

Fig. 7/20: Zone-selective interlocking (ZSI) of series- or parallel-connected circuit-breakers (block diagram)

[back to page 138](#)

their characteristic curves – including safety margins – do not touch. Generally, a safety margin of 100 ms between the reference curves is usually sufficient in practice (Fig. 7/22).

### Selectivity between fuse and downstream circuit-breaker

#### Selectivity ratios in the overload range

In order to achieve selectivity in the overload range, a safety margin of  $t_A \geq 1$  s is commonly required between the lower tolerance band of the fuse and the characteristic curve of the inverse-time-delay overload release (Fig. 7/23).

In the case of short-circuits, it is important to remember that, after the releases in the circuit-breaker have tripped, the fuse continues to be heated during the arcing time. As described before, the selectivity limit is approximately at the point where a safety margin of 100 ms between the lower tolerance band of the fuse and the operating time of the instantaneous overcurrent release, or the delay time of the short-time-delay overcurrent release is undershot.

#### Selectivity ratios in the short-circuit range

A reliable and usually relatively high selectivity limit for the short-circuit range can be determined in the  $I^2t$  diagram. Here, the maximum value of the let-through  $I^2t$  value of the circuit-breaker is compared to the minimum value of the prearcing  $I^2t$  value of the fuse (Fig. 7/24). Since these values are maximum and minimum values, tolerances are obsolete.

#### Selectivity with parallel feed-in

##### Improving selectivity with parallel feed-in units

With parallel feed-in to a busbar, the total short-circuit current  $I_{k\Sigma}$  that occurs in the faulted branch circuit comprises the partial short-circuit currents  $I_{k\text{ part}}$  in the individual feed-in units and represents the base current in the grading diagram (Fig. 7/25). This is the case for all fault types.

#### Two identical feed-in units

If a short circuit occurs in the branch circuit downstream of the circuit-breaker Q1, the total short-circuit current  $I_{k\Sigma}$  of  $\leq 20$  kA, for example, flows through this circuit, while the feeder circuit-breakers Q2 and Q3 – with the branch circuit

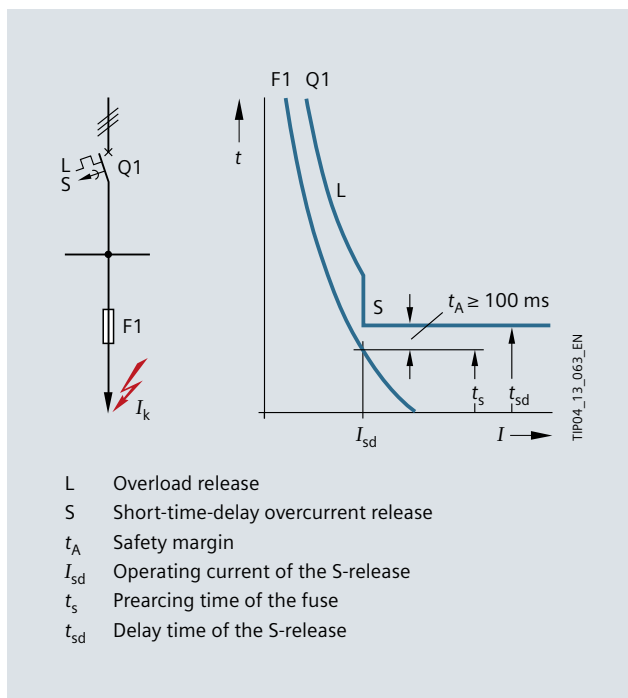

Fig. 7/22: Selectivity between circuit-breaker with LS-releases and downstream fuse for short-circuit protection

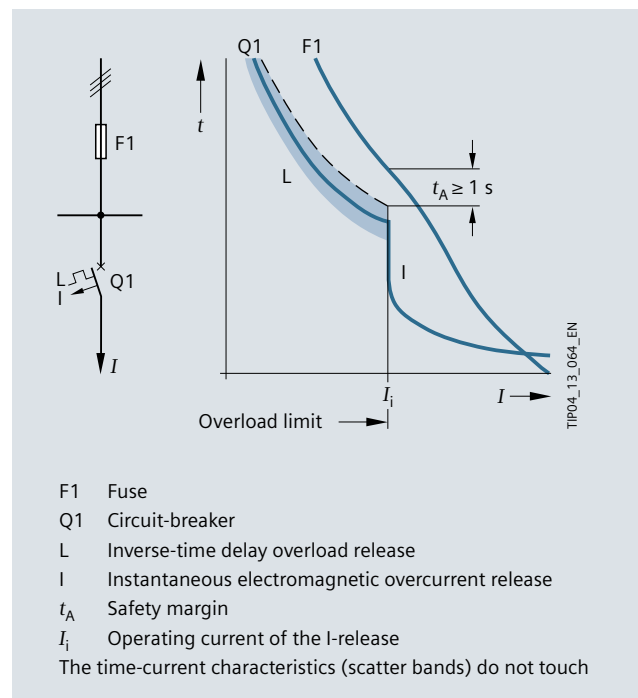

Fig. 7/23: Selectivity between fuse and downstream circuit-breaker for the overload range



at the busbar centre and feeding lines of equal length – each carry only half this current, i.e.  $\leq 10$  kA.

*Additional current selectivity with parallel transformer operation*

In the grading diagram, the tripping characteristic of circuit-breakers Q2 and Q3 must, therefore, be considered in relation to the base current of circuit-breaker Q1. Since the total short-circuit current is ideally distributed equally among the two feed-in units (ignoring the load currents in the other branch circuits) with the branch circuit located at the busbar centre, the tripping characteristic of circuit-breakers Q2 and Q3 can be shifted optimally to the right along the current scale by a characteristic displacement factor of 2 up to the line  $I_{k\Sigma}$ , which represents the base current for this fault condition. The result of this is selectivity both with regard to time and current.

If the characteristic curve of the individual circuit-breaker is used instead of the shifted characteristic, the exact short-circuit current (distribution) which flows through the circuit-breaker must be taken into consideration. With asymmetrical configurations and with incoming (feeding) and outgoing circuits located in the busbars, short-circuit current distribution will differ according to the impedance along the feeding lines. This is particularly important for fused branch circuits especially with high protection, for

example 630 A to 1,000 A. It is important to ensure that a safety margin of  $\geq 100$  ms between the tripping characteristic of the S-release and the prearcing time/current characteristic of the LV HRC fuse is provided not only during parallel operation, but also during single operation of transformers.

When setting the releases of circuit-breakers Q1, Q2, and Q3, it must be ensured that selectivity is also achieved for operation with one transformer and for all short-circuit currents (1- to 3-phase). For cost-related reasons, S-releases for the feeder circuit-breakers must also be provided for low and medium rated fuse currents, as the resulting current selectivity of I-releases is insufficient.

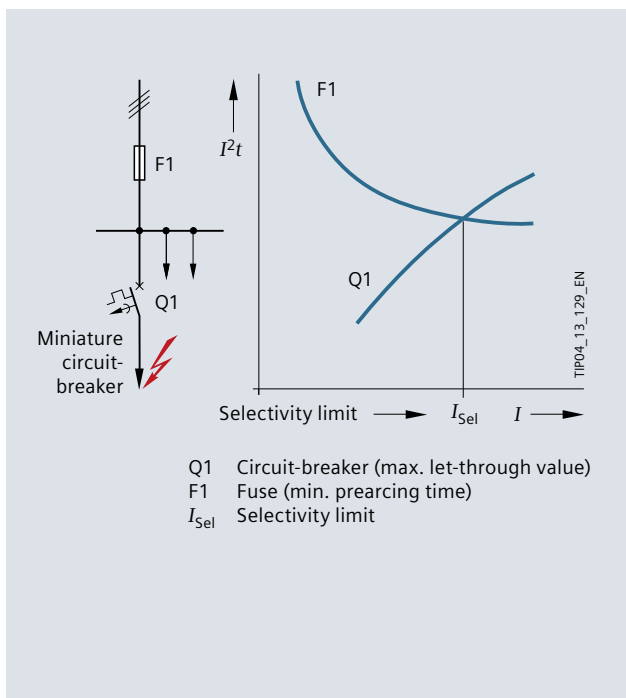

Fig. 7/24: Selectivity between fuse and downstream circuit-breaker for short-circuit protection [back to page 140](#)

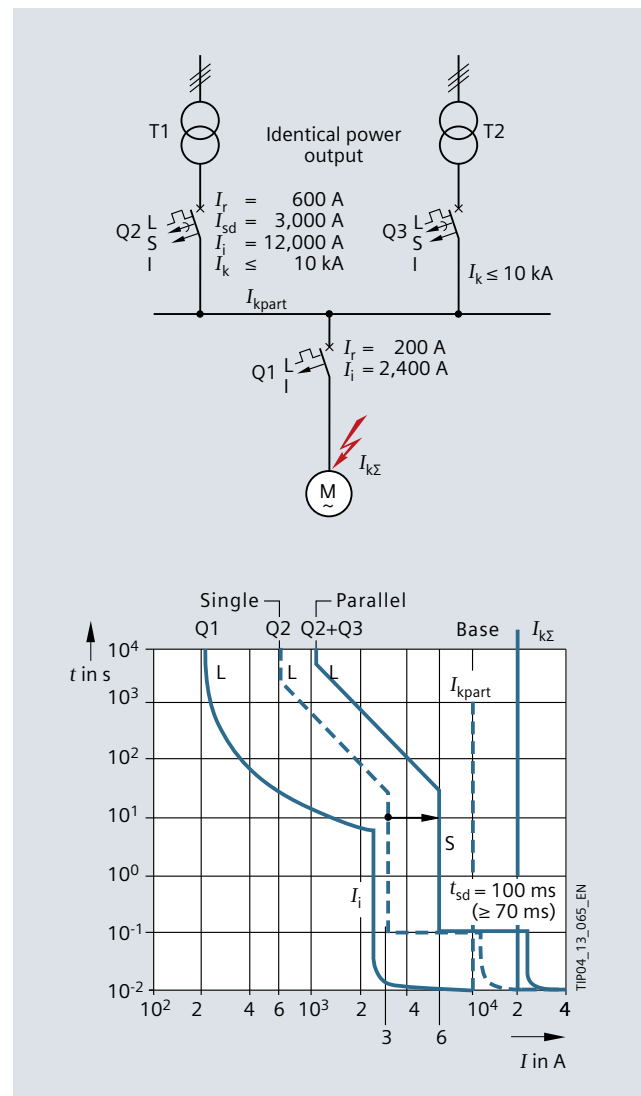

Fig. 7/25: Selectivity with two feeding transformers of the same rating and operating simultaneously; example with branch circuit in the busbar centre [back to page 140](#)

### Three identical feed-in units

During parallel operation of three transformers, the selectivity conditions are in principle improved more than with two units owing to the additionally achieved current selectivity, as the characteristic displacement factor is between 2 and 3. Here, too, LS-releases are required in the feed-in units to obtain unambiguous selectivity conditions for the circuit-breaker.

Furthermore, it is necessary to provide additional I-releases to allow a fault between the transformer and feeder circuit-breaker to be detected as shown in Fig. 7/26. To this end, the S-releases of the circuit-breakers Q1 to Q3 must be set to a value less than  $I_k$  and the I-releases greater than  $I_k$ , but less than  $I_{k\Sigma}$ . The highest and lowest fault currents are important here. The I-releases will then disconnect only the faulted transformer branch circuit at the high-voltage and low-voltage side. The circuit-breakers in the "healthy" feed-in units remain operative.

### Parallel-connected feed-in units via tie breakers

Tie breakers must perform the following protection functions in fault situations:

- Instantaneous release with faults in the vicinity of the busbar
- Relief of branch circuits of the effects of high total short-circuit currents

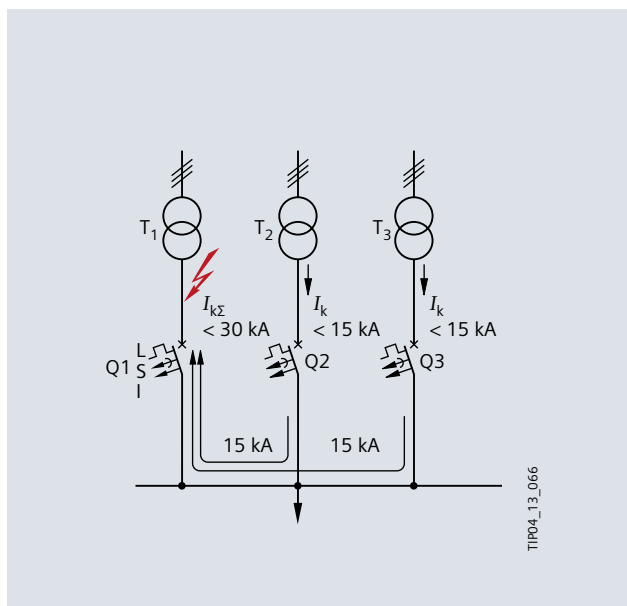

Fig. 7/26: Selectivity with three feeding transformers operating simultaneously

### Selecting the circuit-breakers

The type of device used in the branch circuits and the selectivity ratios depend primarily on the question whether circuit-breakers with current-zero cut-off, i.e. without current limiting, or with current limiting are used as tie breakers. Instantaneous, current-limiting tie breakers relieve the outgoing circuits of the effects of high unlimited total peak short-circuit currents  $I_p$  and, therefore, permit the use of less complex and less expensive circuit-breakers.

### Setting the overcurrent releases in tie breakers

In order to be able to draw unambiguous conclusions about selectivity in case of relatively low short-circuit currents, as are present in the branch circuits of sub-distribution boards, the values set for the overcurrent releases in tie breakers must be as high as possible.

### With two feed-in units

With two feed-in units and depending on the fault location (left or right busbar section or branch circuit), only the associated partial short-circuit current (for example  $I_{k\text{part}2}$ ) flows through the tie breaker Q3 as shown in Fig. 7/27.

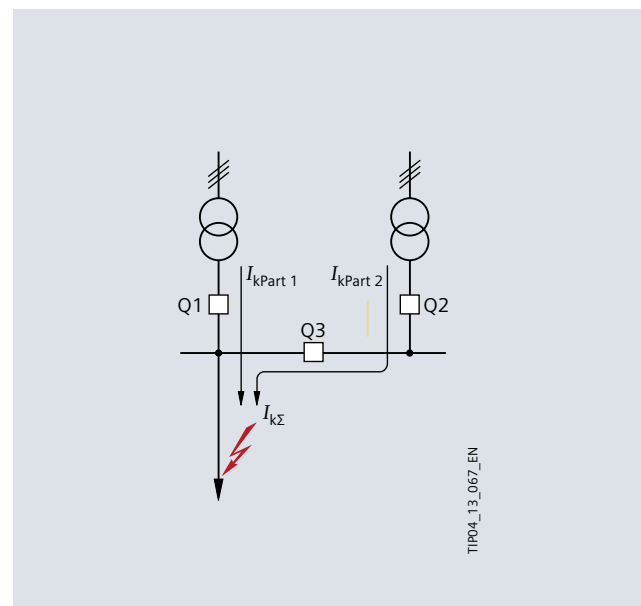

Fig. 7/27: Short-circuit splitting through the tie breaker Q3 with two feeders Q1 and Q2

### With three feed-in units and fault

With three feed-in units, the ratios are different depending on which of the branch circuits shown in Fig. 7/28 a and b is faulted.

- If a fault occurs at the outgoing circuit of the centre busbar section (Fig. 7/28a), approximately equal partial short-circuit currents flow through the tie breakers Q4 and Q5
- If a fault occurs at the branch circuit of the outer busbar section, (Fig. 7/28b), two partial short-circuit currents flow through the tie breaker Q4

#### Computer-assisted selectivity check

Precise values for the short-circuit currents flowing through the tie breakers are required to permit optimum setting of the overcurrent releases. They provide information concerning selective characteristics with a large number of different fault currents, and are determined and evaluated with the aid of a planning tool such as SIMARIS design.

### Selectivity and undervoltage protection

If a short circuit occurs, the system voltage collapses to a residual voltage at the short-circuit location. The magnitude of the residual voltage depends on the fault impedance and, therefore, the voltage at the short-circuit location drop to almost zero. Generally, however, arcs will be present during short circuits that generate arc-drop voltages between approximately 30 V and 70 V, speaking from experience. This voltage, starting at the fault location, increases proportionately to the intermediate impedance with increasing proximity to the power source.

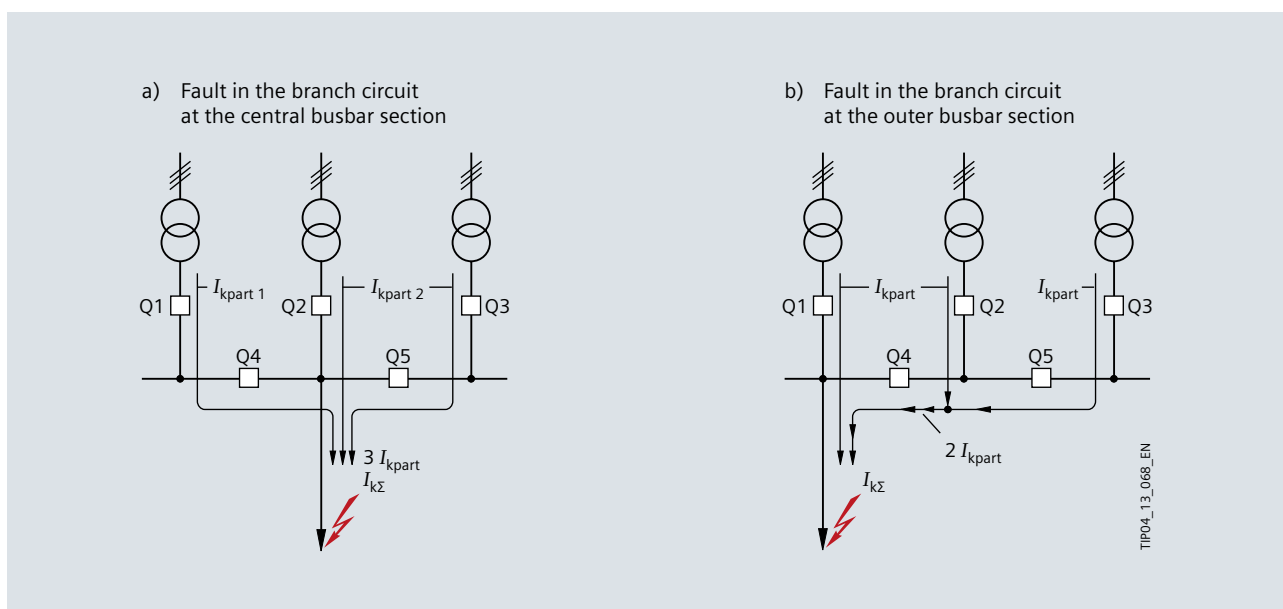

Fig. 7/28: Splitting of short-circuit currents for the purpose of setting the overcurrent releases in the tie breakers Q4 and Q5 in case of three feed-in units and faults a and b in the outgoing circuit of different busbar sections

Fig. 7/29 illustrates the voltage conditions in a low-voltage switchgear installation with a "dead" short circuit.

If a short circuit occurs at K1 (Fig. 7/29a), the rated operating voltage  $U_e$  drops to  $0.13 \cdot U_e$  at the busbar of the sub-distribution board and to  $0.5 \cdot U_e$  at the busbar of the main distribution board. The nearest upstream circuit-breaker Q1 clears the fault. Depending on the size and type of the circuit-breaker, the total breaking time is up to 30 ms for zero-current interrupters and a maximum of 10 ms for current-limiting circuit-breakers.

If a short circuit occurs at K2 (Fig. 7/29b), the circuit-breaker Q2 opens. It is equipped with a short-time-delay overcurrent release (S). The delay time is at least 100 ms. During this time, the rated operating voltage at the busbar of the main distribution board is reduced to  $0.13 \cdot U_e$ . If the rated operating voltage drops to  $0.7 - 0.35$  times this value and voltage reduction takes longer than approximately 20 ms, all of the circuit-breakers with undervoltage releases will disconnect. All contactors also open if the rated control supply voltage collapses to below 75% of its rated value for longer than 5 ms to 30 ms.

*Tripping delay for contactors and undervoltage releases*

Undervoltage releases and contactors with tripping delay are required to ensure that the selective overcurrent protection is not interrupted prematurely. They are not necessary if current-limiting circuit-breakers, which have a maximum total clearing time of 10 ms, are used.

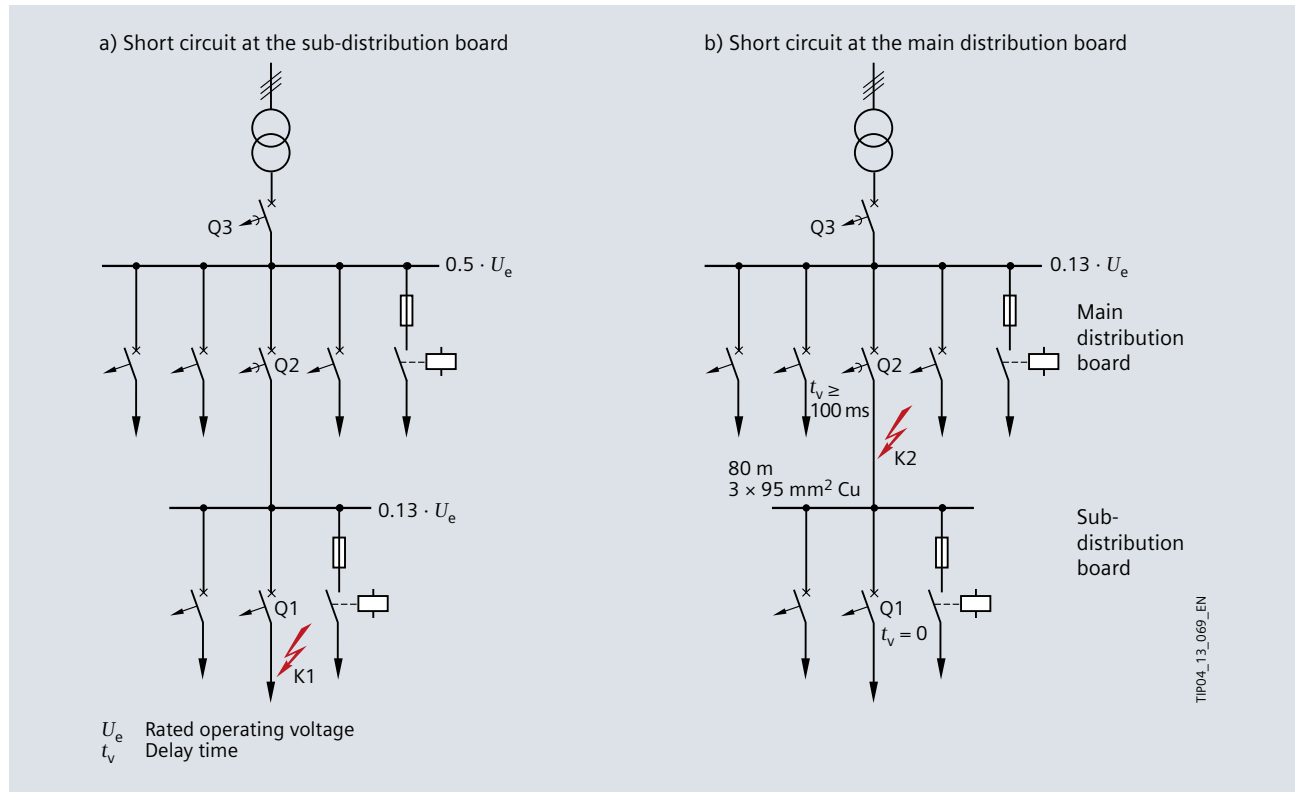

Fig. 7/29: Voltage conditions for short-circuited low-voltage switchgear installation with a main and sub-distribution board

### 7.5.2 Selectivity in Meshed Systems

Two selectivity functions must be performed in meshed systems:

- Only the short-circuited cable may be disconnected from supply
- If a short circuit occurs at the terminals of a feeding transformer, only the faulted terminal may be disconnected from supply

#### Node fuses

The nodes of a meshed low-voltage system are normally equipped with cables of the same cross section and with LV HRC fuses of operational class gG of the same type and rated current (Fig. 7/30).

If a short circuit (K1) occurs along the meshed system cable, the short-circuit currents  $I_{k3}$  and  $I_{k4}$  flow to the fault location. Short-circuit current  $I_{k3}$  from node "a" comprises the partial currents  $I_{k1}$  and  $I_{k2}$  which may differ greatly depending on the impedance ratios.

#### Permissible current ratio

Selectivity of the fuses at node "a" is achieved if fuse F3, through which the total current  $I_{k3}$  flows, melts and fuse F1 or F2, through which the partial short-circuit  $I_{k1}$  or  $I_{k2}$  flows, remains operative. The permissible current ratio  $I_{ki} / (I_{k1} + I_{k2})$  with  $i = 1$  oder 2, for high short circuits is 0.8 for Siemens LV HRC fuses (400 V, up to 400 A).

#### Feeder circuit-breaker for power transformers in the meshed network

In a multi-phase meshed system (Fig. 7/31), that means feeding several medium-voltage lines and transformers, reverse power feed from the low-voltage network to the fault location should be prevented if a fault occurs in a main substation or medium-voltage line. A network master relay (reverse power relay) used to perform this task at the low-voltage side of the transformer. Today, circuit-breakers with electronic trip units, having an S-release with an  $I^2t$  characteristic for example, are used for this task.

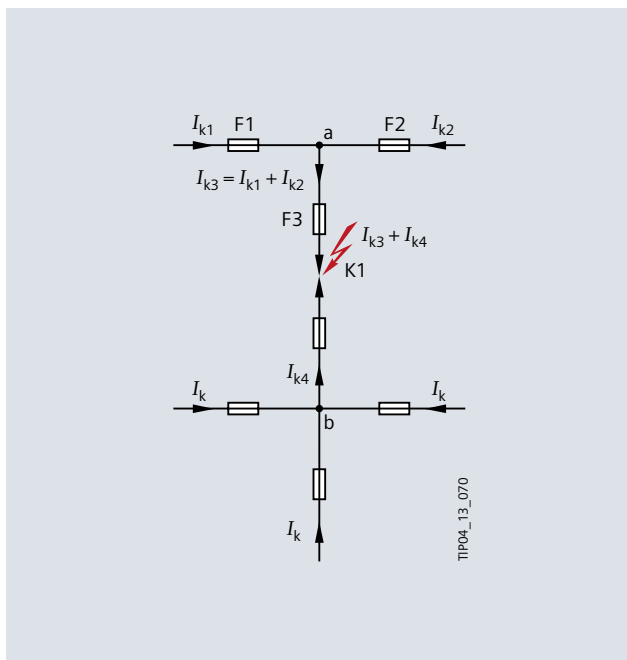

Fig. 7/30: Short-circuited cable with its two feed-in nodes a and b

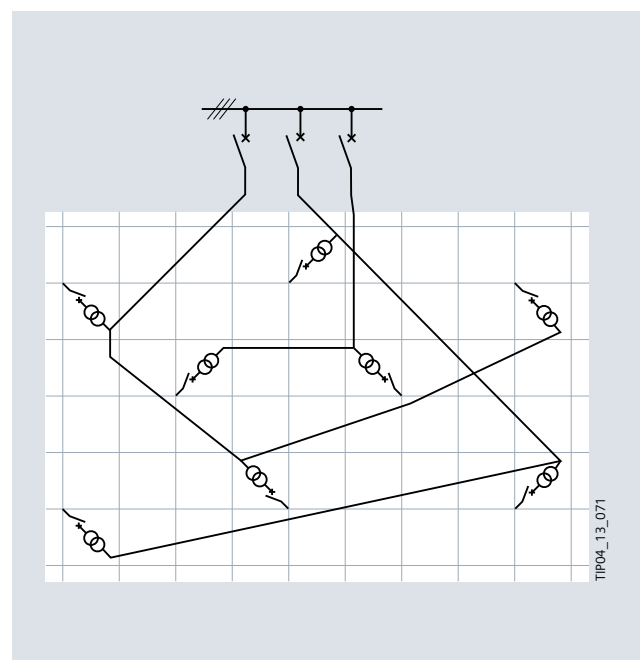

Fig. 7/31: Example of a meshed system with multi-phase feeding

1

2

3

4

5

6

7

8

9

10

11

12

13

14

15

16

17

If a short circuit occurs at the high-voltage side of the transformer (fault location K1) – see Fig. 7/32 – or between transformer and circuit-breaker for mesh-connected networks (fault location K2), or in the cable (fault location K3), then the HV HRC fuse at the high-voltage side will respond. At the low-voltage, reverse power is fed to the fault location through the low-voltage circuit-breaker with  $I^2t$  characteristic in the S-release. As the sum of all short-circuit current quantities from all the other transformers flows through this circuit-breaker, this circuit-breaker will trip fast enough and thus selectively, owing to its  $I^2t$  characteristic.

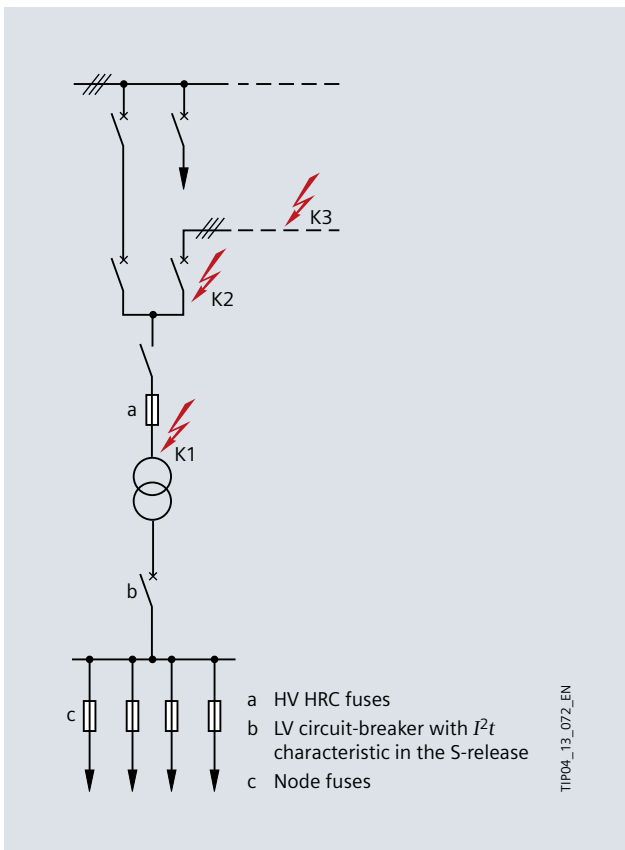

Fig. 7/32: Block diagram of feed-in at a substation in a meshed network

## 7.6 Protection of Low-Voltage Capacitors

According to IEC 60831-1 (VDE 0560-46), capacitor units must be suitable for continuous operation with a current whose r.m.s. value does not exceed 1.3 times the current which flows with a sinusoidal rated voltage and frequency. Owing to this reserve (considering capacity tolerances which amount to 1.5 times the rated capacity, the maximum permissible current can increase to 1.15 times the rated current), no overload protection is provided for capacitor units in the majority of cases.

### Capacitors in systems with harmonic components

The capacitors can only be overloaded in networks with devices which generate high harmonics (for example converter-fed drives). The capacitors, together with the series-connected transformer and short-circuit reactance of the primary system, form an anti-resonant circuit. Resonance phenomena occur if the natural frequency of the resonant circuit matches or is close to the frequency of a harmonic current generated by the power converter.

### Reactor-connected capacitors

The capacitors must be provided with reactors to prevent resonance. An LC resonant circuit, the resonance frequency of which is below the lowest harmonic component (250 Hz) in the load current, is used instead of the capacitor. The capacitor unit is thus inductive for all harmonic currents that occur in the load current and can, therefore, no longer form a resonant circuit with the system reactance.

### Settings of the overload relay

If thermal time-delay overload relays are used to provide protection against overcurrents, the tripping value can be set at 1.3 to 1.43 times the rated capacitor current, since, allowing for the permissible capacitance deviation, the capacitor current can be  $1.1 \cdot 1.3 = 1.43$  times the rated capacitor current. With transformer-heated overload relays or releases, a higher secondary current flows due to the changed transformation ratio of the current transformers caused by the harmonic components. This may result in premature tripping.

### Harmonics suppression by means of filter circuits

Another possibility how to prevent resonances is freeing the superordinate system from harmonics as much as possible by using filter circuits. The filter circuits are also series resonant circuits which, unlike the reactor-connected capacitors, are tuned precisely to the frequencies of the harmonic currents to be filtered. As a result, the impedance is almost zero.

### Short-circuit protection

LV HRC fuses in operational class gG are most frequently used in capacitor units for short-circuit protection. A rated fuse current of 1.6 to 1.7 times the rated current of the connected capacitor modules is selected to prevent the fuses from responding in the overload range and when the capacitors switch.

*Note: Fuses, fuse-switch-disconnectors, capacitors, and contactors must be matched during configuration. We recommend using tested, complete assembly kits.*

## 7.7 Protection of Distribution Transformers

The following devices are used for protection tasks in medium-voltage systems:

### HV HRC fuses

HV HRC fuses are used in the range of up to about 630 kVA and – provided that lines need to be switched rarely – in connection with switch-disconnectors for the short-circuit protection of spur lines and transformers.

### Circuit-breakers

If more frequent switching is required and for transformers rated 630 kVA and higher, we recommend protection by circuit-breakers. This is often specified by the DSO for the consumer substation as well.

### Protection relays

Protection relays connected to current transformers (protection core) can perform all protection-related tasks irrespective of the magnitude of the short-circuit currents and rated operating currents of the required circuit-breakers.

### Digital protection

Modern protection equipment is controlled by microprocessors (digital protection) and supports all of the protection functions required for a medium-voltage branch circuit.

### Protection as component of the energy automation system

In addition, digital protection provides the option to acquire operational and fault data, to store and retrieve them through the serial data interfaces. Digital protection can, therefore, be incorporated in substation control and protection systems as an autonomous component.

### Current transformer rating for protection purposes

Requirements in accordance with IEC 60044-1,-2, and -3 (VDE 0414-44-1, -2, and -3) apply to current transformers. Current transformers with cores in accuracy class 5P or 10P must be used for the connection of protection devices. The required rated output and dimensioning factor must both be determined on the basis of the information provided in the protection relay descriptions.

### Overcurrent protection

To make overcurrent protection of cables and transformer branch circuits future-proof, all phases of those circuits, usually 3 phases, shall be equipped with current transformers. The neutral-point connection of the medium-voltage network must be considered here.

### Relay operating currents with emergency generator operation

Care should be taken to ensure that the operating currents of the protection relays provided for normal system operation are also attained in the event of faults during emergency operation using generators with relatively low rated outputs.

### 7.7.1 Dimensioning of Protection

It must be noted that the best possible fault clearing time in the event of a short circuit will be from 70 to 120 ms when circuit-breakers and protection relays are used. The fault clearing time for a switch and fuse combination is about 5 ms. Owing to this short fault clearing time and the current-limiting effect of HV HRC fuses, a short circuit will hardly affect the voltage quality. These differences in the fault clearing times are also significant for the comparison of hazards for people and installations.

Public 10-kV medium-voltage grids are normally characterized by a short-circuit power between 250 and 350 MVA (20-kV grids up to 500 MVA). The corresponding energy transmitted at 70 ms (3.5 oscillation periods in the 50-Hz grid) for circuit-breakers amounts to about 650 to 900 kW in the 10-kV grid (respectively 1,300 kW in the 20-kV grid). These values are proportionally lower if the fuse clears the fault – 45 to 65 kW for the 10-kV grid, respectively 90 kW for the 20-kV grid.

These values are below the limit values [9]

- Less or equal to 250 kW for personal safety in case of an enclosed switchgear installation
- Less or equal to 100 kW for system function protection ("complete functional endurance of all system parts and equipment" [9])

The anticipated selectivity conditions must be checked before the protection concept is chosen and details determined.



## Protection by HV HRC fuses

The rated current of the HV HRC fuses specified by the manufacturers for the rated output of each transformer should be used when dimensioning the HV HRC fuses. According to VDE 0670-402, the following parameters are considered:

- Transformer inrush current  
The lowest rated current is dimensioned by the inrush currents generated when the transformers are energized and is 1.5 to 2 times the rated transformer current. In practice it is normally sufficient if the maximum energizing current of the transformer has a selective clearance of 20% from the characteristic fuse curve at 0.1 s
- Minimum breaking current  $I_{a\ min}$   
In order to determine the maximum rated current, the minimum breaking current  $I_{a\ min}$  of the fuse must be exceeded in the event of a short circuit at the secondary side of the transformer reaching as far as the busbars in the installation. Actual practice has shown that a 25% minimum safety margin of  $I_{a\ min}$  should be established in relation to the short-circuit current  $I_k$  of the transformer between the calculated maximum short-circuit current in the vicinity of the busbar at the low-voltage side (converted to the medium-voltage side) and the minimum breaking current  $I_{a\ min}$  (the circle in the prearcing time/current characteristic)

The fuse-link can be chosen between the specified limits according to the selectivity requirements (see Fig. 7/33).

## Protection by switch-disconnectors and HV HRC fuses

As a switch-disconnector is normally used for transformer protection when HV HRC fuses are used, their limited current breaking capacity must be taken into account. According to IEC 62271-105 (VDE 0671-105), the following two conditions must be met among others:

- The transient current of the HV HRC fuse/switch-disconnector combination must be lower than the breaking capacity of the switch-disconnector
- A secondary-side transformer short circuit should be cleared by the HV HRC fuse in order to relieve the switch-disconnector from high transient recovery voltages

On account of the extremely complex interaction of this combination and the data required, such as the characteristic time-current curve of the HV HRC fuse, time to contact separation, and rated transient current of the switch-disconnector, the manufacturer of the medium-voltage switchgear must provide the fuse type and rated current to be used for the specified transformer. In practice it may

happen under difficult conditions, that simultaneous compliance with both standards VDE 0670-402 and IEC 62271-105 (VDE 0671-105) is not possible. In these cases, the switchgear manufacturer should be consulted, or a circuit-breaker should be used for transformer protection.

## Grading of HV HRC with LV HRC fuses in feed-in circuits

Grading HV HRC fuses and LV HRC fuses is mainly used for transformers with rated outputs of max. 400 kVA, when LV HRC fuse-switch-disconnectors or motor fuse-disconnectors (maximum rated current is 630 A) are also applied (example: Fig. 7/34); circuit-breakers with overcurrent releases are used at the low-voltage side for rated outputs  $\geq 500$  kVA.

It is acceptable for the prearcing time/current characteristics F2 (LV HRC) and F3 (HV HRC) – referred to 0.4 kV – to touch or intersect, and the switch-disconnector to be possibly tripped on the high-voltage side by the upstream HV HRC fuse, since both fuses protect the same system element and interruption will occur in all cases (limited selectivity). HV HRC fuses with higher rated currents (for example 80 A as shown in Fig. 7/34) would not be suitable here, since their lowest breaking current  $I_{a\ min}$  does not have a safety margin of 25% at minimum below the short-circuit current  $I_k$  which the transformer lets through (maximum 10.5 kA).

A non-selective fuse response, as demonstrated in the example of the 50 A HV HRC fuse towards the 630 A low-voltage fuse (Fig. 7/34) may result in damage of unblown fuse-links in case of faults in the low-voltage busbar, so that the tripping characteristic is changed and the fuse may trip at any time under any load – even below its rated current. In the event of protection tripping by the HV HRC fuse, or the low-voltage fuse, both fuse links should always be replaced altogether. This applies to all descriptions below and the examples given for HV HRC fuses, where non-selective protection at the transformers' low-voltage side is provided (Fig. 7/35 to Fig. 7/37).

## Grading of HV HRC fuses with low-voltage circuit-breakers and downstream LV HRC fuses

### Requirements

Selectivity is to be established between the protection devices of the branch circuits and those of the feed-in, which together form a functional unit; the safety margins of the protection devices must also be considered (Fig. 7/35 and Fig. 7/36).

### Grading between LV HRC fuses and L-/S-releases

Selectivity is achieved with the 315-A fuse-link used in the example (Fig. 7/35). With L- and S-releases the excitation values  $I_R$  and  $I_{sd}$  as well as the delay times  $t_R$  and  $t_{sd}$  must be matched to the transformer output and the downstream LV HRC fuse. If a low-voltage circuit-breaker is used with an additional  $I^4t$  characteristic in the L-release, higher-rated LV HRC fuses can be used in the branch circuits owing to their characteristics, and selectivity will still be maintained (Fig. 7/36). If circuit-breakers, such as the SENTRON 3WL, are used instead of LV HRC fuses, branch circuits can be configured with higher currents while maintaining selectivity (Fig. 7/37), as the S-releases can be adapted accordingly with regard to their excitation currents  $I_{sd}$  and delay times  $t_{sd}$ .

### Grading between HV HRC fuses and L-/S-releases

Since the protection devices in the feed-in system form a functional unit, a restriction in selectivity in the upper short-circuit current range is accepted in case of faults in the vicinity of the busbars (as indicated by the circle in the diagram for the 80 A HV HRC fuse in Fig. 7/35 to Fig. 7/37), because faults inside the switchgear in this short-circuit range can virtually be ruled out for Siemens low-voltage SIVACON switchboards.

Even partial selectivity of the low-voltage circuit-breaker in the branch circuit with the HV HRC fuse (Fig. 7/35) in the upper short-circuit range is often acceptable, as dead 3-phase short-circuit currents can be ruled out in practice, and faults will be below the selectivity level just a few meters downstream of the protection device (here: the intersection of the HV HRC fuse curve and S-release curve). In these cases, the more cost-effective variant, the HV HRC fuse, is preferred to a medium-voltage circuit-breaker, and not the fulfilment of 100% selectivity.

The requirement of full selectivity and the use of HV HRC fuses can often be met by implementing zone-selective interlocking (ZSI) with low-voltage circuit-breakers. All of the downstream distribution systems and protection

devices, as well as the short-circuit currents likely to be present at the fault locations must then be taken into account.

### Tolerances of HV HRC fuses

According to EC 60282-1 (VDE 0670-4), the tolerance of HV HRC fuse-links can be  $\pm 20\%$ . Siemens HV HRC fuse-links have a tolerance of  $\pm 10\%$ .

## Protection by circuit-breakers with definite-time overcurrent protection (DMT)

### Requirements

The two feed-in circuit-breakers in Fig. 7/38 to Fig. 7/41 form a functional unit and must be selectively graded towards the protection devices at the low-voltage side.

### DMT protection

Nowadays, digital devices are used to provide DMT protection in practically all applications. They have broader setting ranges, allow a choice between definite-time and inverse-time overcurrent protection or overload protection, provide a greater and more consistent level of measuring accuracy and are self-monitoring.

### 2-zone DMT protection

If DMT protection is applied, whose protection function merely consists of the two  $I>$  and  $I>>$  (ANSI 50/51) short-circuit zones, and if no further measures are taken for transformer protection, the  $I>$  zone is normally used as standby protection for the low-voltage side. This means the  $I>$  zone is set to 1.5 up to 2.0 times the transformer's rated current. Consequently, the size of the branch circuits in the main distribution system at the low-voltage level is limited in order to ensure selectivity there. For example, with a 630 kVA transformer this means:

- A fuse of a maximum size of 160 A can be used in the main distribution (Fig. 7/38). In practice, this roughly corresponds to 20% of the rated transformer current
- With circuit-breakers, their maximum size depends on the setting ranges of the circuit-breakers' releases and their tolerances, as well as the protection devices in the branch circuits of the sub-distribution board. Selective grading using SENTRON 3WL circuit-breakers (630 A or even 800 A) is possible (Fig. 7/39). Generally speaking, circuit-breakers can be used with current ratings of 50 % up to 80% of the rated transformer current

Intersection of the characteristics Q2 and Q3 in the middle short-circuit range is permissible because

- the low-voltage circuit-breaker and the medium-voltage circuit-breaker form a functional unit
- the L-release of the low-voltage circuit-breaker Q2 protects the transformer against overloading, which practically is present in the range of 1.0 – 1.3 times the rated current of the transformer only
- a safety margin of 50 ms to 100 ms exists between the operating value of the  $I>$  tripping of the DMT protection (lower tolerance band) and the upper tolerance bands of the characteristic LV HRC fuse curve F1 and the S-release of the circuit-breaker Q1 in the branch circuits, which means that selectivity is ensured

### 2-zone DMT protection with overload protection

If advanced DMT protection equipment is applied, which provides additional overload protection  $I_{th}$  (ANSI Code 49) besides the two standard short-circuit protection zones  $I>/I>>$ , the  $I>$  zone can act as a “proper” short-circuit protection zone, and the overload protection function can be used as transformer protection and standby protection for the low-voltage side. Above all, this allows the use of larger fuses in the low-voltage branch circuits. In the context of overload protection, it must be ensured that preloading is also considered for selectivity evaluation. For example, with a 630-kVA transformer this means:

- A fuse of a maximum size of 315 A can be used in the main distribution (Fig. 7/40). In practice, this roughly corresponds to 35 % of the rated transformer current
- With circuit-breakers, their maximum size depends on the setting ranges of the circuit-breakers’ releases and their tolerances, as well as the protection devices in the branch circuits of the sub-distribution board. Selective grading using SENTRON 3WL circuit-breakers (630 A or even 800 A) is possible (Fig. 7/41). Generally speaking, circuit-breakers can be used with current ratings of 50 % up to 80 % of the rated transformer current

### Current transformer sizing for protection purposes

Dimensioning a current transformer depends on many parameters if correct functioning of the relays is to be ensured. This includes:

- maximum short-circuit currents present
- requirements set by the protection devices on the current transformers
- secondary-side rated current transformer current
- burden of the connecting cables and other connected protection devices
- power output and inherent burden of the current transformer
- rated accuracy limit factor of the current transformer

Authorized information on the precise rating of these current transformers matching the protection relays applied and the prevailing boundary conditions can only be given by the specialized technical departments of the equipment manufacturer. In practice, the rated currents of the current transformers used for DMT protection devices can be determined as follows:

- General use of 1-A current transformers (secondary side) if numerical protection technology is applied. Usually, this approach almost completely rules out possible problems regarding non-saturated transmission of short-circuit currents and the burdening of the current transformers for DMT protection in advance
- The primary rated current of the current transformer should be 1.2 to 2.0 times the transformer rated current. This protects the current transformer against damage through overload, as today – unless required otherwise – current transformers without overload capability are used for cost reasons
- The primary rated current of the current transformer should not exceed four times the transformer rated current in order to prevent significant impacts of current transformer tolerances on measurements and current evaluations

For our example this means:

To match the high-voltage-side rated transformer current of 36.4 A (630 kVA, 10 kV), a primary current transformer current between  $1.2 \cdot I_{nTr}$  and  $2 \cdot I_{nTr}$  – meaning in the range of [43.7 A ... 72.8 A] – should be selected. A 60/1-A current transformer is a good solution.

1

Setting the short-circuit current zones  $I>$ ,  $I>>$ , and time delays  $t>$ ,  $t>>$

2

• Short-circuit current zone  $I>$

3

Assuming that additional overload protection  $I_{th}$  has also been set in the DMT protection device, the short-circuit current zone  $I>$  is chosen in such a way that it will excite at a safety margin of approximately 20% towards the minimum 1-phase fault at the secondary side of the transformer. Please note that on account of the transformer's Dy vector group, this fault is shown at the primary side as follows:

4

$$I_{k \text{ min prim}} = \frac{I_{k1 \text{ min sec}}}{\ddot{u} \cdot \sqrt{3}}$$

5

$\ddot{u}$  representing the transformer's transformation ratio. In the example from Fig. 7/40 and Fig. 7/41:

6

$$\ddot{u} = 10 \text{ kV} / 0.4 \text{ kV} = 25$$

7

Assuming a minimum single-phase short-circuit current of approx. 12.5 kA (in this example: transformer with 630 kVA,  $u_{kr}$  6%), there is:

8

$$I_{k \text{ min prim}} \approx 288 \text{ A}$$

9

Consequently, when considering a safety margin of approximately 20%, there is:

10

$$I'_{k \text{ min prim}} = 0.8 \cdot I_{k \text{ min prim}} \approx 230 \text{ A}$$

11

With a selected value

12

$$I'_{k \text{ min prim}} = 210 \text{ A}$$

13

there is the setting value:

14

$$I> \geq \frac{210 \text{ A}}{60/1} = 3.5 \text{ A}$$

15

The delay of the  $I>$  zone is set to  $t \geq 0.5 \text{ s}$ .

16

17

• Short-circuit current zone  $I>>$

The short-circuit current zone  $I>>$  is set in such a way, that it will only detect primary-side faults which are then cleared as fast as possible. Usually, it is chosen with a safety margin of approximately 20% above the maximum 3-phase fault at the secondary side of the transformer.

When taking the  $c_{max}$  factor for low-voltage systems into account – as given in the standard for short-circuit current calculation, IEC 60909-0 (VDE 0102) –, the maximum secondary-side three-phase short-circuit current can initially be approximated as:

$$I_{k3 \text{ max sec}} = \frac{c_{max} \cdot I_{nTr \text{ sec}} \cdot 100}{u_{kr}}$$

$$I_{k3 \text{ max prim}} = \frac{I_{k3 \text{ max sec}}}{\ddot{u}}$$

With the 630-kVA transformer of the example and a  $c_{max}$  factor = 1.1 there is

$$I_{k \text{ min prim}} \approx 667 \text{ A}$$

Consequently, when considering a safety margin of approximately 20%, there is:

$$I'_{k \text{ min prim}} = 1.2 \cdot I_{k \text{ min prim}} \approx 800 \text{ A}$$

A selected value of  $I'_{k \text{ max prim}} = 810 \text{ A}$  results in the following setting value:

$$I>> \geq \frac{810 \text{ A}}{60/1} = 13.5 \text{ A}$$

In practice, the time delay of the  $I>>$  zone is set to 50 to 100 ms.

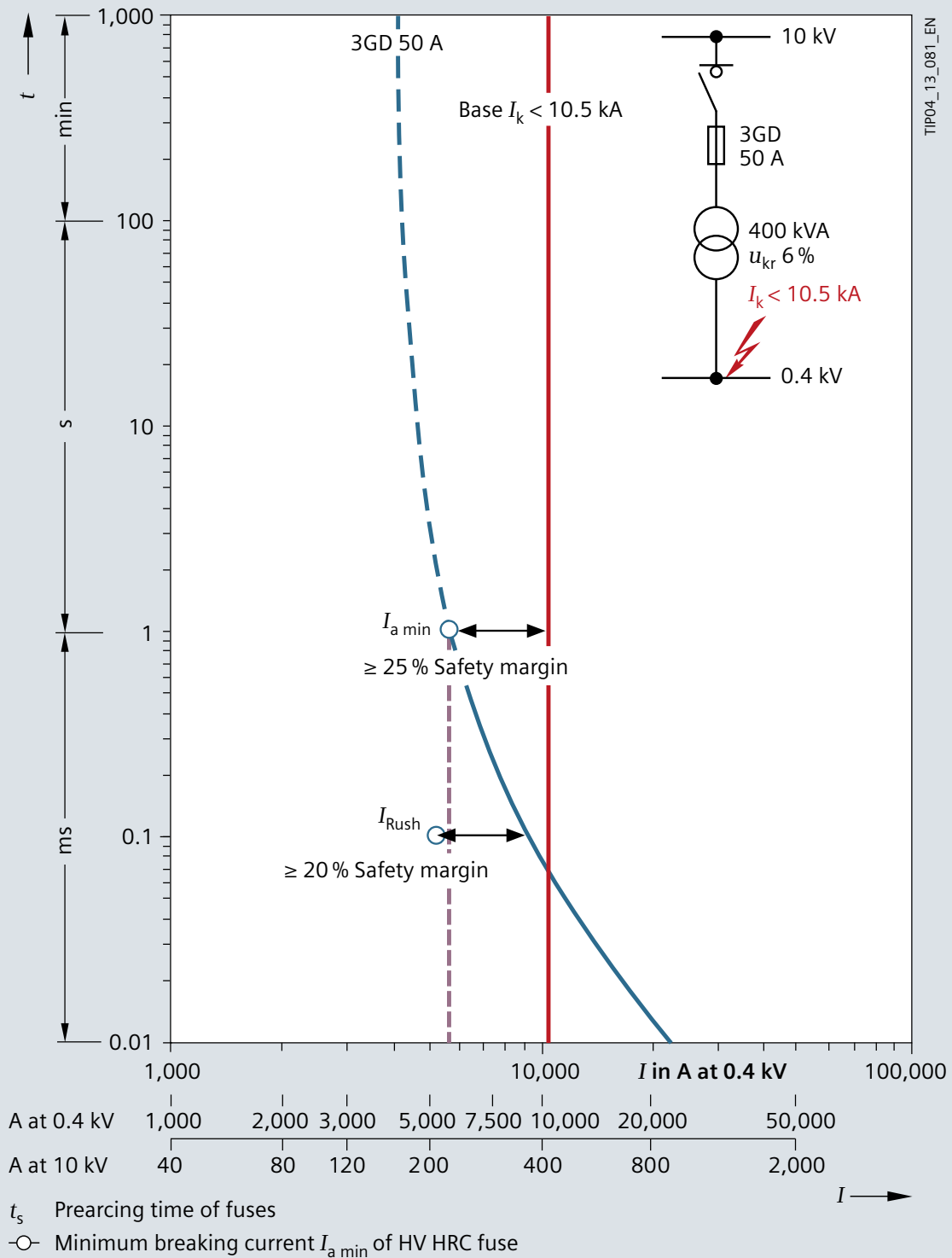

TIP04\_13\_081\_EN

Fig. 7/33: Example for dimensioning a HV HRC fuse acc. to the minimum breaking current of the HV HRC fuse and the energizing current of the transformer

[back to page 149](#)

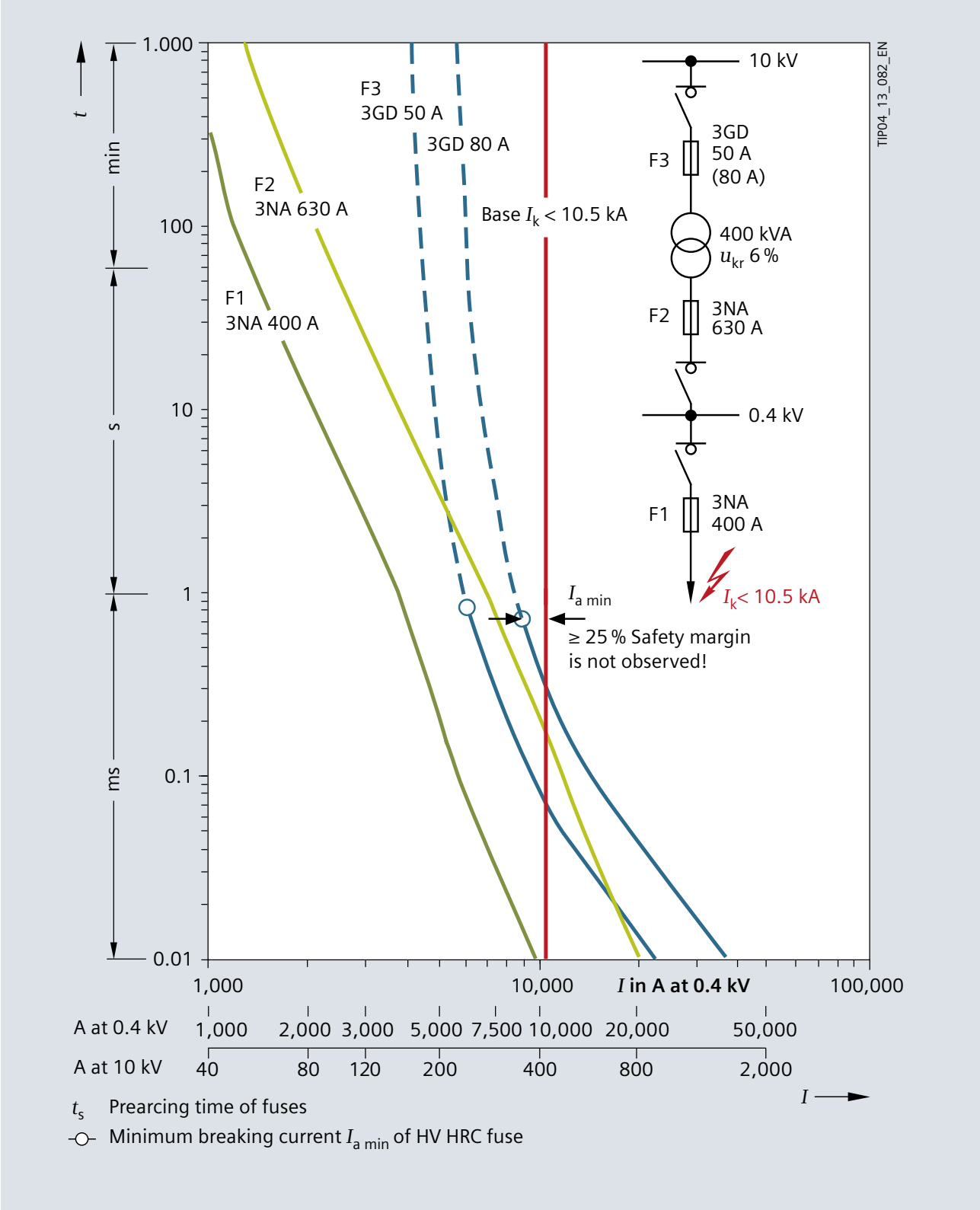

Fig. 7/34: Example of grading HV HRC fuses – LV HRC fuses in the branch circuit and a 400 kVA transformer back to page 149

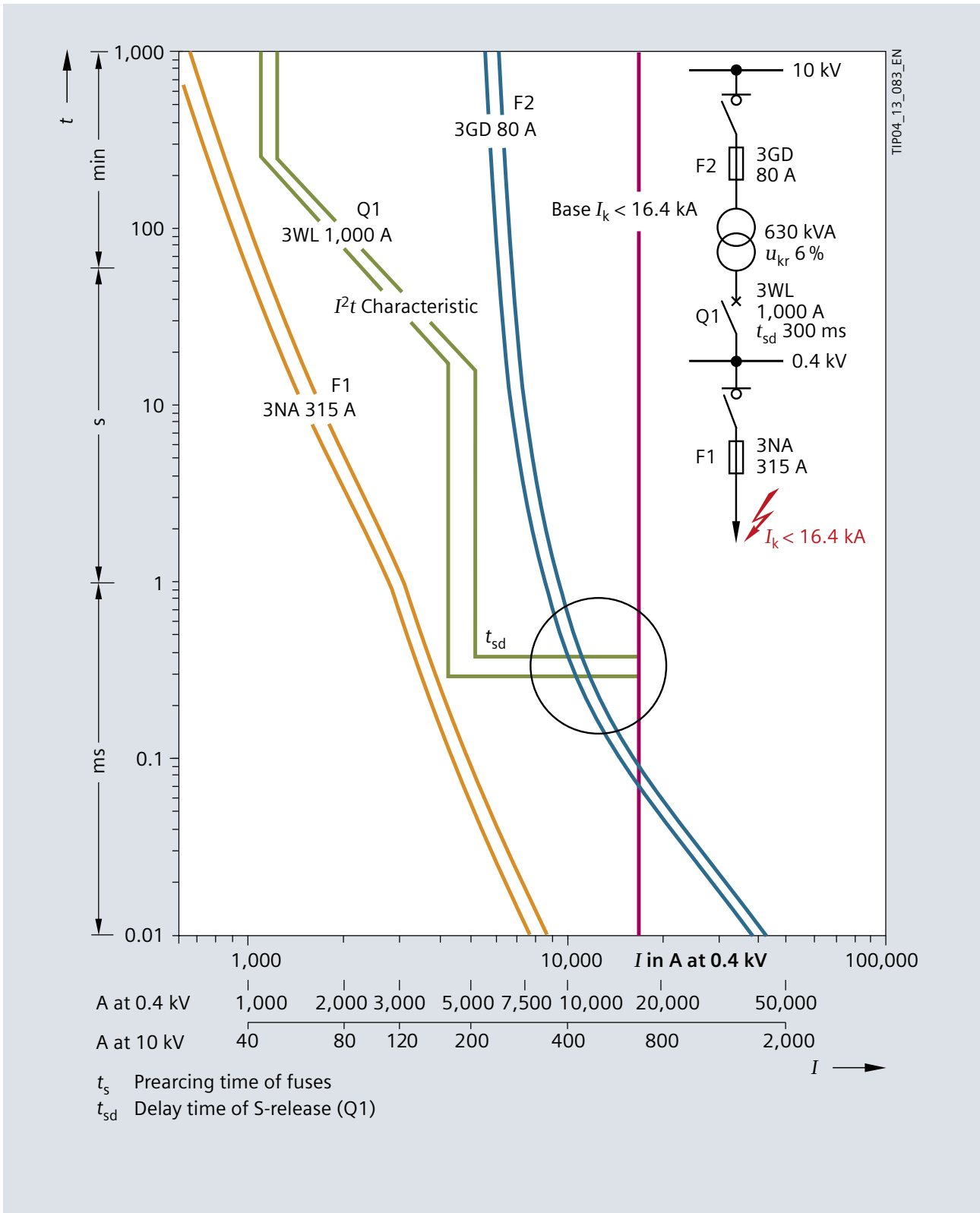
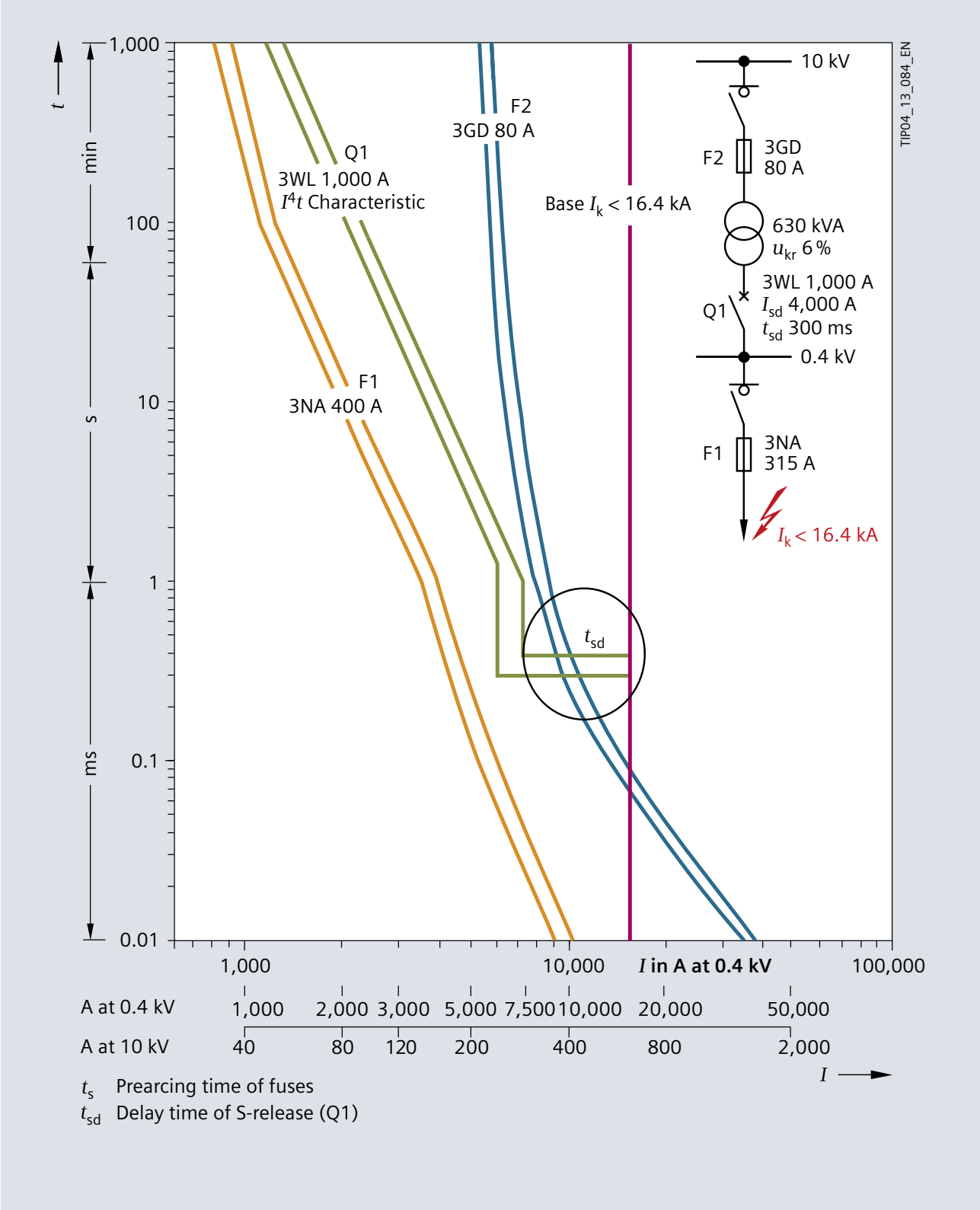

Fig. 7/35: Example of grading a HV HRC fuse F2 with circuit-breaker Q1 and downstream LV HRC fuse F1 in the branch circuit

[back to page 149](#)



TIP04\_13\_084\_EN

Fig. 7/36: Example of grading a HV HRC fuse F2 with circuit-breaker Q1 (optional  $I^4t$  characteristic of the L-release) and downstream LV HRC fuse F1 in the branch circuit [back to page 150](#)



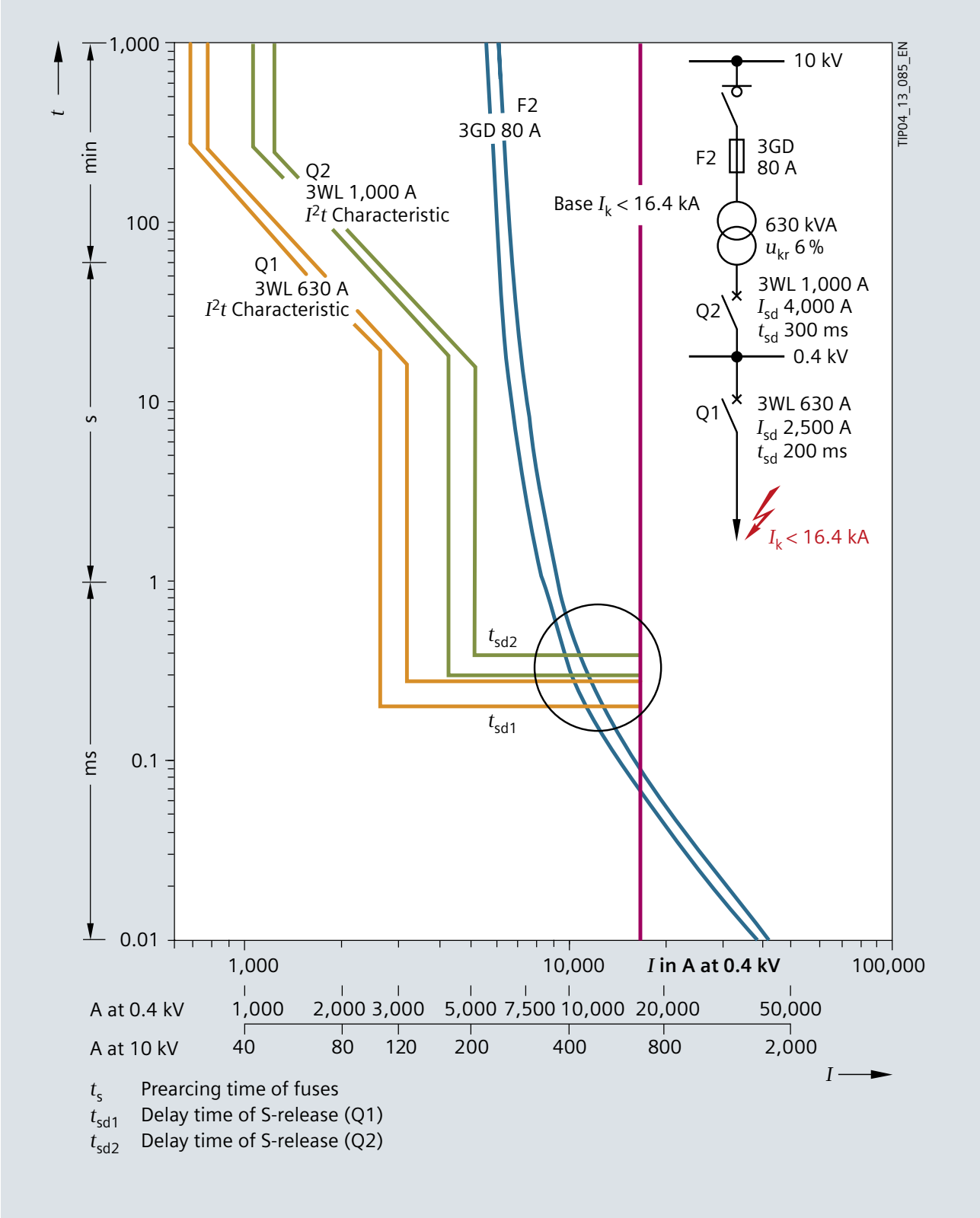

Fig. 7/37: Example of grading a HV HRC fuse F2 with circuit-breaker Q2 and downstream circuit-breaker Q1 with an LSI-release in the branch circuit back to page 149

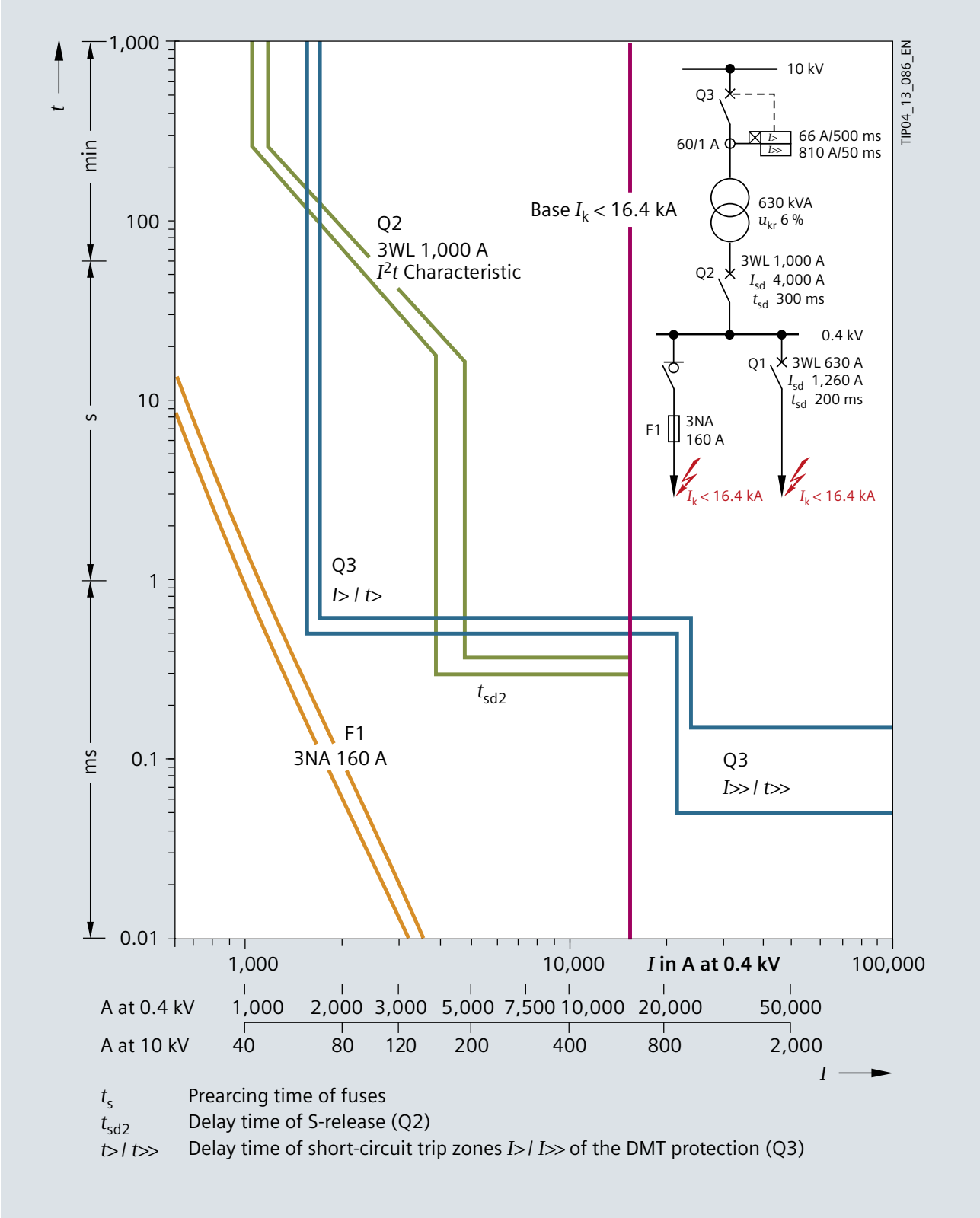

Fig. 7/38: Example of grading a circuit-breaker with DMT protection (Q3), 3WL circuit-breaker, 1,000 A with LSI-release (Q2) and downstream branch circuits, e.g. with LV HRC fuse 160 A (F1), in a transformer branch circuit supplying 630 kVA [back to page 150](#)

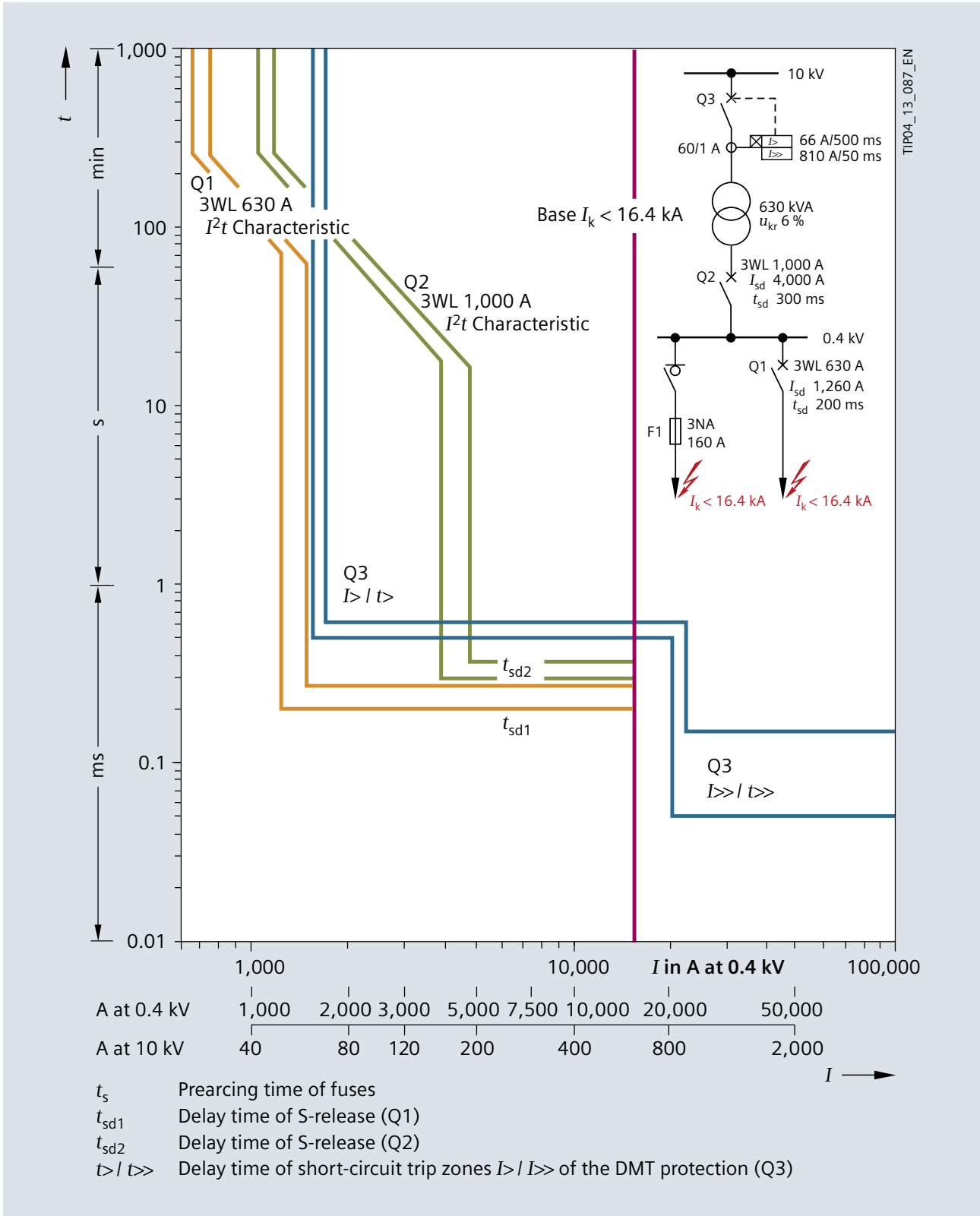

Fig. 7/39: Example of grading a circuit-breaker with DMT protection (Q3), 3WL circuit-breaker, 1,000 A with LSI-release (Q2) and downstream branch circuits with 3WL circuit-breaker, 630 A, LSI-release (Q1), in a transformer branch circuit supplying 630 kVA [back to page 150](#)

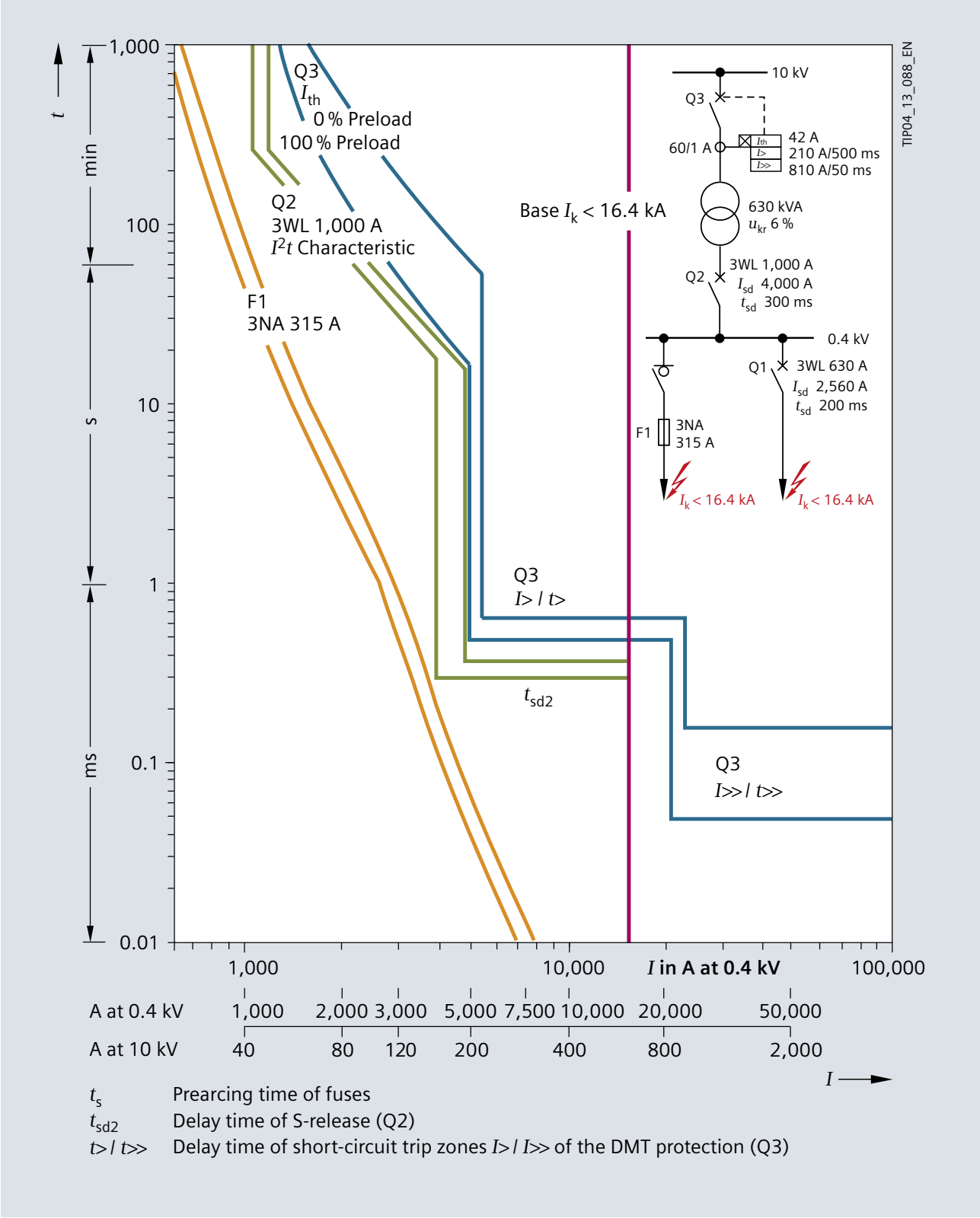

Fig. 7/40: Example of grading a circuit-breaker with DMT protection and overload protection (Q3), 3WL circuit-breaker, 1,000 A with LSI-release (Q2) and downstream branch circuits with LV HRC fuse 315 A (F1), in a transformer branch circuit supplying 630 kVA

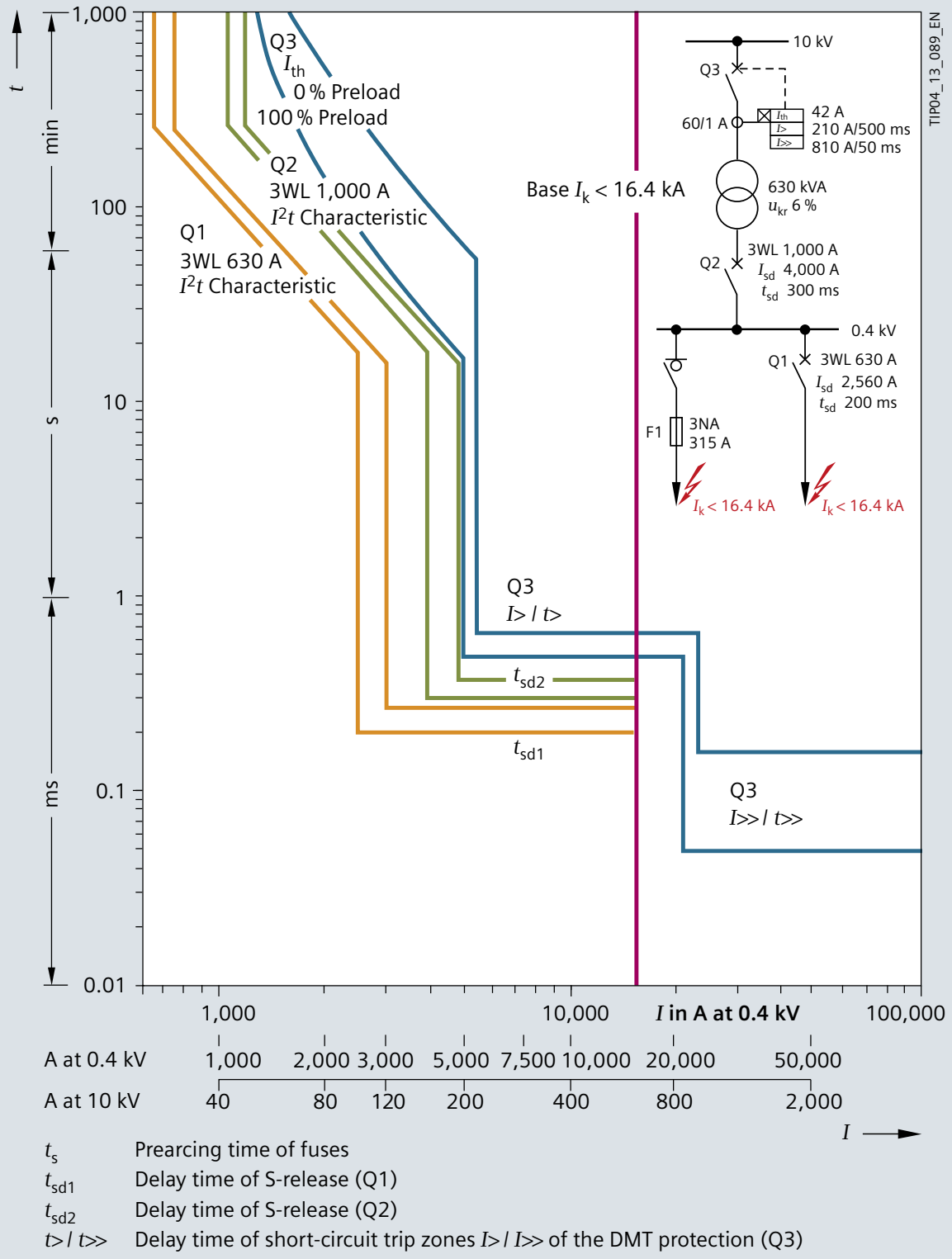

Fig. 7/41: Example of grading a circuit-breaker with DMT protection (Q3), 3WL circuit-breaker, 1,000 A with LSI-release (Q2) and downstream branch circuits with 3WL circuit-breaker, 630 A, LSI-release (Q1), in a transformer branch circuit supplying 630 kVA [back to page 150](#)

1

## 7.7.2 Equipment for Protecting Distribution Transformers against Internal Faults

2

The following signalling devices and protection equipment are used to detect internal transformer faults:

3

- Devices for monitoring and protecting liquid-cooled transformers such as Buchholz protectors, temperature detectors, contact thermometers, etc.
- Temperature monitoring systems for GEAFOL resin-encapsulated transformers comprising:
  - temperature sensors in the low-voltage winding and
  - signalling and tripping devices in the incoming-feeder switchpanel

4

5

6

The thermistor-type thermal protection protects the transformer against overheating resulting from increased ambient temperatures or overloading. Furthermore, it allows the full output of the transformer to be utilised irrespective of the number of load cycles without the risk of damage to the transformer.

7

8

These signalling and protection devices needn't be included in the grading diagram.

9

10

11

12

13

14

15

16

17



# Chapter 8

## Medium-Voltage Switching Devices and Switchgear

8.1 Medium-Voltage Switchgear	165
8.2 Medium-Voltage Switching Devices	175
8.3 Medium-Voltage Protection	185

# 8 Medium-Voltage Switching Devices and Switchgear

According to international rules, there are only two voltage levels:

- Low voltage (LV): up to and including 1 kV AC (or 1.5 kV DC)
- High voltage (HV): above 1 kV AC (or 1.5 kV DC)

Most electrical appliances used in household, commercial and industrial applications work with low voltage. High voltage is used not only to transmit electrical energy over very large distances, but also, finely branched, for regional distribution to the load centres. However, as different high voltages are used for transmission and regional distribution, and since the tasks and requirements of the switching devices and switchgear also differ greatly, the term "medium voltage" has come to be used for the voltages required for regional power distribution. Medium voltage is considered to be part of the high voltage range above 1 kV AC up to and including 52 kV AC.

Most operating voltages in medium-voltage grids are in the 3 kV AC to 40.5 kV AC range.

The electrical transmission and distribution systems not only connect power stations and electricity consumers, but also, with their "meshed systems", form a nationwide backbone with reserves for reliable supply and for the compensation of load differences. High operating voltages (and therefore low currents) are preferred for power transmission in order to minimise losses. The voltage is then transformed to the usual values of the low-voltage grid in the load centres close to the consumer.

In public power supplies, the majority of medium-voltage grids are operated in the 10 kV to 30 kV range (operating voltage). The values vary greatly from country to country, depending on the historical technological development and the local conditions. Apart from the public supply, there are other voltages in industrial plants with medium-voltage grids that depend on the consumers; in most cases, the operating voltages of the installed motors are decisive. Operating voltages between 3 kV and 15 kV are very often used in industrial supply networks.

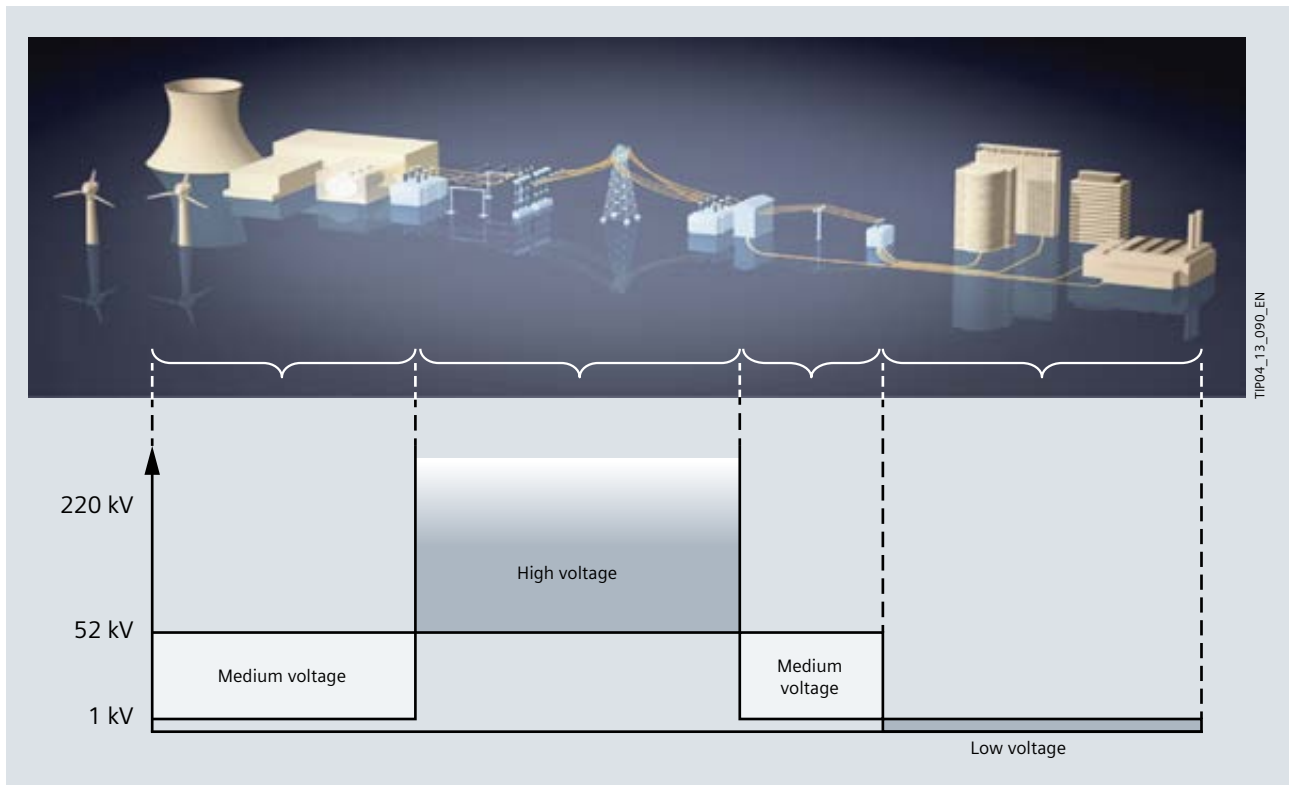

Fig. 8/1: Voltage levels between the power plant and the consumer



## 8.1 Medium-Voltage Switchgear

When planning switchgear, functions and influencing factors must be matched and an economically efficient solution must be found among the offerings of manufacturers. For this there is no simple recipe with an unambiguous solution because:

- The tasks of a switchgear substation can vary greatly
- Many influencing factors are interdependent
- The same influencing factors and requirements can be weighted differently by different manufacturers

Generally, a switchgear substation shall provide a high level of safety so that both operator protection and fault-free network operation is ensured. It must meet the requirement of touch protection and exclude the possibility of maloperation. If a fault occurs nevertheless, its impact on the fault location should be limited and not entail personal injury.

In analogy to distribution grids, switchgear can be assigned to the primary or secondary distribution level:

- What is characteristic for the primary distribution level are high load and short-circuit currents and high-end secondary features of the switchgear with regard to protection, measuring, and (remote) control. At the primary distribution level (Fig. 8/2) you will find the main substation, where energy is fed in with a higher voltage and transformed to the medium-voltage level. The switchgear is almost completely equipped with circuit-breakers. They switch large consumers, mostly in industrial plants, or cable rings which feed switchgear at the secondary distribution level
- At the secondary distribution level, the switchgear is equipped with switches or a mixture of switches and circuit-breakers, where the proportion of switches clearly dominates. The currents are lower, short-circuit

protection is often ensured by the assigned circuit-breaker at the primary distribution level. The requirements placed on secondary features are usually lower.

Typical forms are:

- The consumer substation from which the energy is distributed at the fed-in line voltage (medium voltage). A load transfer switch (coupling) in the substation can form the property border between the supply company and the customer if the customer wants to develop his switchgear part independently. In that case, measuring and metering equipment for billing will also be available
- The substation, also called secondary unit substation, where the energy is transformed from medium into low voltage and distributed as such. In industrial plants, substations are often installed in the production centres which are also load centres. Therefore, these substations are called load-centre substations. For very compact-built substations which are not accessible, the designation 'small' or 'compact substation' has become popular

### 8.1.1 Standards for the Design and Installation of Medium-Voltage Switchgear

The standards distinguish between two main groups of medium-voltage switchgear:

- Factory-assembled, type tested plants with
  - Metal enclosure in accordance with IEC 62271-200 (VDE 0671-200)
  - Moulded-plastic enclosure in accordance with IEC 62271-201 (VDE 0671-201)
- On-site or workshop-built switchgear in accordance with IEC 61936-1 (VDE 0101-1), as it is rarely built nowadays

In the following, we will describe the metal-enclosed, type tested medium-voltage switchgear in accordance with IEC 62271-200 (VDE 0671-200), since both moulded-plastic enclosed and on-site built, i.e. workshop-built plants are manufactured significantly less frequently. The high manufacturing and testing expense often amortise only if high quantities are produced and the production is standardised accordingly. The technical data must be verified by type tests. The manufacturing quality is monitored by routine tests.

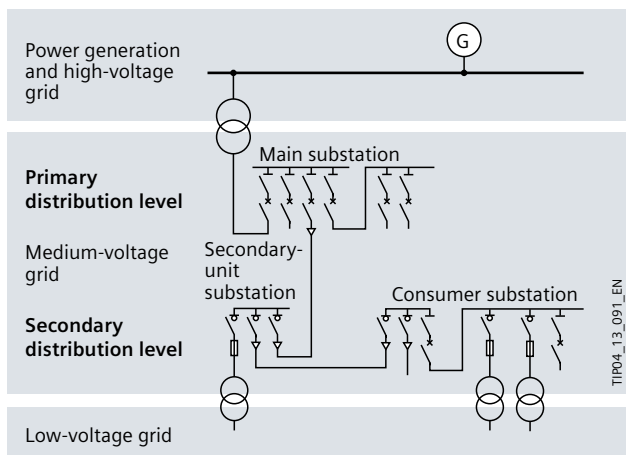

Fig. 8/2: Structure of the voltage and power distribution levels

### 8.1.2 Configuration Parameters

The selection parameters for the configuration of switchgear can be distinguished as follows:

- Pre-defined for example connection to earth, grid voltage, grid frequency, neutral-point connection, ambient conditions, peak short-circuit current
- Conditionally selectable for example insulation level, neutral-point connection, overvoltage protection, short-circuit duration, type of operating area, plant design

- Any selection for example switchgear type, switching devices and their operating mechanisms, busbar circuitry, compartments and partitions, operational availability, internal arc qualification

Tab. 8/1 gives an overview of the configuration parameters and characteristics which may play a part in the planning. The most important aspects are presented in more detail below.

Selection parameter		Determinants
Primary rated values	<ul style="list-style-type: none"> <li>• <math>U_r</math> Rated voltage</li> <li>• Rated insulation level</li> <li><math>U_d</math> Short-duration power-frequency withstand voltage</li> <li><math>U_p</math> Lightning impulse withstand voltage</li> </ul>	<ul style="list-style-type: none"> <li>• Line voltage</li> <li><i>Insulation coordination</i></li> <li>• Neutral-point connection</li> <li>• Cable / overhead line grid</li> <li>• "Critical" consumers</li> <li>• Overvoltage protection</li> <li>• Altitude</li> <li>• Environmental influences (pollution)</li> </ul>
	<ul style="list-style-type: none"> <li>• Rated withstand capacity</li> <li><math>I_p</math> Peak current</li> <li><math>I_k</math> Short-time current</li> <li><math>t_k</math> Short-circuit duration</li> <li>• Rated switching capacity</li> <li><math>I_{ma}</math> Short-circuit making current</li> <li><math>I_{sc}</math> Short-circuit breaking current</li> </ul>	<ul style="list-style-type: none"> <li>• Grid characteristics</li> <li>• Consumers and power quality</li> <li>• Grid protection, response times</li> <li>• Selectivity criteria</li> </ul>
	<ul style="list-style-type: none"> <li>• <math>I_r</math> Rated operating current</li> <li>Busbar</li> <li>Feeder circuits</li> </ul>	<ul style="list-style-type: none"> <li>• Load (feeder circuit), power to be distributed (busbar)</li> <li>• Ambient temperature</li> <li>• Reserves / service continuity</li> </ul>
Selection parameter		Determinants
Busbar circuit	<ul style="list-style-type: none"> <li>• Single / Double busbar</li> <li>• Bus sectionalizer / busbar coupler, longitudinal (BCL)</li> <li>• Switch-over (BCL) using switch or circuit-breaker</li> <li>• Busbar coupler, transversal (BCT) (double busbar)</li> </ul>	<ul style="list-style-type: none"> <li>• System configuration</li> <li>• Grid protection, response times, selectivity criteria</li> <li>• Reserves / service continuity, switch-over times</li> <li>• Operational procedures</li> <li>• Embedded or in-plant power generation, emergency power supply</li> <li>• Power quality (unsteady loads)</li> <li>• Operational procedures</li> </ul>
	<ul style="list-style-type: none"> <li>• Double busbar with common connection</li> <li>• Two single busbar systems</li> </ul>	<ul style="list-style-type: none"> <li>• Frequency of busbar switch-over</li> <li>• Interlockings, switching fault protection</li> <li>• Installation (spatial)</li> </ul>
Selection parameter		Determinants
Switching device	<ul style="list-style-type: none"> <li>• Circuit-breaker</li> <li>• Switch</li> <li>• Contactor</li> <li>• HV HRC fuse</li> </ul>	<ul style="list-style-type: none"> <li>• Operating current and switching task</li> <li>• Switching capacity (fault currents)</li> <li>• Switching frequency</li> <li>• Grid protection, selectivity requirements</li> </ul>

	Selection parameter	Determinants	
Design and panel type	<ul style="list-style-type: none"> <li>• Circuit-breaker panel</li> <li>• Switch panel</li> <li>• Type of construction                             <ul style="list-style-type: none"> <li>– Extendable panels</li> <li>– Block type</li> </ul> </li> </ul>	<ul style="list-style-type: none"> <li>• Primary rated values</li> <li>• Switching devices</li> <li>• Operating current, switching capacity</li> <li>• Grid protection</li> <li>• Numerical ratio of switch panels to circuit-breaker panels</li> <li>• Operational workflows and handling</li> <li>• Conditions of installation</li> <li>• Transportation and mounting</li> <li>• Expandability, electrical/mechanical reserves</li> </ul>	1
			2
Insulation medium	<ul style="list-style-type: none"> <li>• Air (AIS)</li> <li>• Gas (GIS)</li> </ul>	<ul style="list-style-type: none"> <li>• Room climate: temperature cycling, humidity, pollution, salt, aggressive gases</li> <li>• Type of operating site</li> <li>• Place of installation (spatial requirements)</li> <li>• Fire protection requirements (fire load)</li> <li>• Altitude</li> <li>• Switching frequency and switch lifetime</li> </ul>	3
			4
Disconnecter	<ul style="list-style-type: none"> <li>• Withdrawable unit/truck</li> <li>• Disconnecter (fixed-mounted)</li> </ul>	<ul style="list-style-type: none"> <li>• Switching frequency</li> <li>• Service life of components</li> <li>• Operational requirements (access to cable terminations, e.g. for cable test)</li> </ul>	5
			6
Encapsulation	<ul style="list-style-type: none"> <li>• Degree of protection (IP in accordance with IEC 60529, VDE 0470-1)</li> <li>• Internal arc classification (IAC)                             <ul style="list-style-type: none"> <li>– A or B (type of accessibility)</li> <li>– F/L/R (classified sides)</li> <li>– <math>I_A, t_A</math> (arc fault current and duration)</li> </ul> </li> <li>• Pressure relief duct</li> </ul>	<ul style="list-style-type: none"> <li>• Environmental conditions</li> <li>• Personal safety</li> <li>• Type of operating site</li> <li>• Building</li> </ul>	7
			8
Compartments and partitions	<ul style="list-style-type: none"> <li>• Category of service continuity (compartment partitioning LSC – loss of service continuity)                             <ul style="list-style-type: none"> <li>– LSC 1</li> <li>– LSC 2</li> <li>– LSC 2A</li> <li>– LSC 2B</li> </ul> </li> <li>• Accessibility and access control using                             <ul style="list-style-type: none"> <li>– Interlocking</li> <li>– Work instruction + locking</li> <li>– Tools</li> </ul> </li> <li>• Non-accessible switchgear compartment</li> <li>• Partition class                             <ul style="list-style-type: none"> <li>– PM (partition of metal)</li> <li>– PI (partition of insulating material)</li> </ul> </li> </ul>	<ul style="list-style-type: none"> <li>• Operational procedures                             <ul style="list-style-type: none"> <li>– Operating, working</li> <li>– Maintenance requirements</li> </ul> </li> <li>• Servicing/Maintenance (Service life of components)</li> <li>• Operating company instructions</li> <li>• Personnel qualification</li> <li>• Shock-hazard protection during work in progress</li> <li>• Switchgear space requirements</li> </ul>	9
			10

Selection parameter		Determinants
Outgoing feeder components	Cable connection <ul style="list-style-type: none"> <li>– Termination: conventional / plug</li> <li>– Number of cables</li> <li>– Conductor cross sections</li> </ul>	Operating and short-circuit current Switching task <ul style="list-style-type: none"> <li>• Cable / overhead line</li> <li>• Altitude</li> </ul>
	<ul style="list-style-type: none"> <li>• Surge arrester</li> </ul>	
	<ul style="list-style-type: none"> <li>• Voltage transformer                             <ul style="list-style-type: none"> <li>– Earth-fault winding (if required)</li> <li>– Current transformer</li> <li>– Number and data of cores</li> </ul> </li> <li>• Summation current transformer (cable-type current transformer)</li> </ul>	<ul style="list-style-type: none"> <li>• Grid protection</li> <li>• Metering, counting</li> <li>• Control</li> <li>• Neutral earthing</li> </ul>
	<ul style="list-style-type: none"> <li>• Earthing switch                             <ul style="list-style-type: none"> <li>– Class E0, E1 or E2</li> </ul> </li> </ul>	
	Operational procedures	
Selection parameter		Determinants
Busbar components	<ul style="list-style-type: none"> <li>• Measuring transducer</li> <li>• Earthing switch                             <ul style="list-style-type: none"> <li>– Class E0, E1 or E2</li> </ul> </li> <li>• Surge arrester</li> </ul>	<ul style="list-style-type: none"> <li>• Grid protection and measurement</li> <li>• Operational procedures</li> </ul>
Selection parameter		Determinants
Secondary equipment	<ul style="list-style-type: none"> <li>• Protection relays</li> <li>• Equipment for control, interlocking, and switching fault protection</li> <li>• Equipment for metering, counting, measured-value transducers</li> <li>• Equipment for monitoring and communication</li> <li>• Motorized drives</li> <li>• Voltage test system</li> <li>• Damping resistor (for voltage transformer)</li> </ul>	<ul style="list-style-type: none"> <li>• Grid parameters, protection equipment</li> <li>• Grid operation, integration into (industrial) processes and operational procedures</li> <li>• Electromagnetic compatibility</li> </ul>

Tab. 8/1: Overview of the rated values and selection parameters for the configuration of medium-voltage switchgear

### 8.1.3 Medium-Voltage Switchgear Design

Gas-insulated switchgear should be used for the medium-voltage consumer substation. The advantages of gas-insulated switchgear are:

- Lower space requirements (up to approx. 70 % savings with 30 kV) compared to air-insulated switchgear
- Smaller transportation size and consequently easier shipping
- Increased reliability of operation due to hermetically sealed primary switchgear section (adverse impact such as from contamination, small animals, contact, condensation are excluded due to the encapsulation)
- Maintenance-free primary section (no lubrication and readjustment necessary)
- Better eco balance than air-insulated switchgear referred to the entire system life cycle

#### Operator protection

- The gas-insulated switchgear is safe to touch thanks to its earthed metal enclosure
- HV HRC fuses and cable terminations are only accessible if branch circuits are earthed
- Operation is only possible if the enclosure is fully sealed (and any doors closed)
- A maintenance-free pressure absorption system, laid out as “special cooling system” reduces pressure-related and thermal impacts of an arc fault so that personnel and building will be safe (Fig. 8/3).

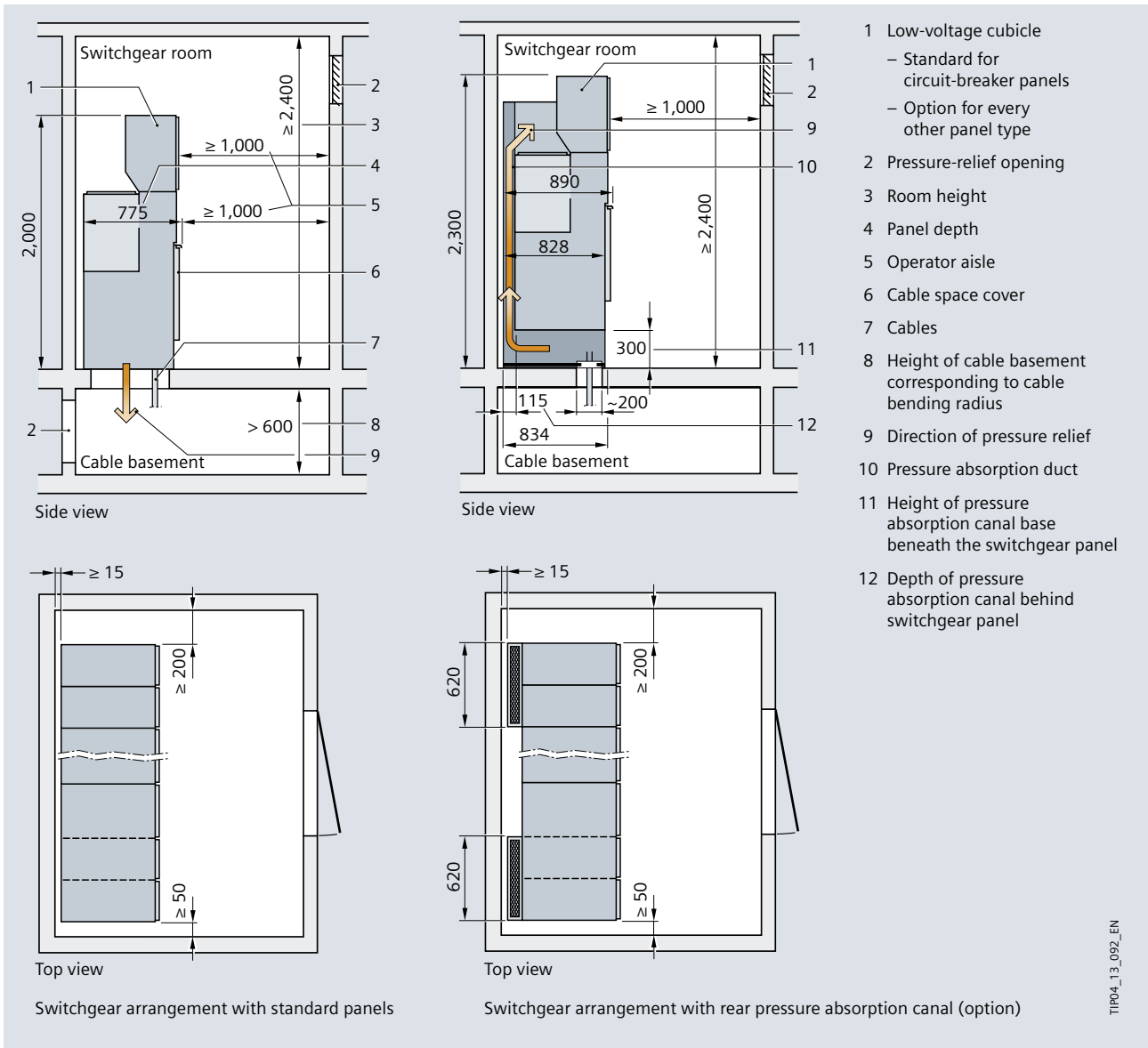

Fig. 8/3: Room layout for switchgear with pressure relief downward (left) and with pressure absorption duct

[back to page 168](#)

**Expandability**

The switchgear should be extendible with a minimum time expense. A modular system with ordering options for busbar extensions on the right, left or both sides provides the best prerequisite for this:

- Individual panels and panel blocks can be mounted side-by-side and extended as desired – no gas work required on site
- Low-voltage compartment (cubicle) is available in two heights, wired to the switchgear panel by means of plug connectors
- All panels can be replaced at any time

**Installation site**

The switchgear shall be usable as indoor installation in accordance with IEC 61936-1 (VDE 0101-1). A distinction is made between:

- Switchgear types in locations with no access from the public, outside closed off electrical operating areas. Switchgear enclosures can only be removed with the aid of tools and operation by ordinary persons must be prevented
- Closed electrical operating areas: A closed electrical operating area is a room or location used solely for the operation of electrical switchgear and is kept locked.

Access is only granted to electrically skilled persons and electrically instructed persons; for ordinary persons only when accompanied by electrically skilled or instructed persons.

**Operating and maintenance areas**

- These are corridors, connecting passages, access areas, transportation and escape routes
- Corridors and access ways must be sufficiently dimensioned for work, operation and transportation of components
- Corridors must have a minimum width of 800 mm
- Corridor width must not be obstructed by equipment protruding into the corridor, such as permanently installed drives or switchgear trucks in disconnected position
- The width of the escape route must be at least 500 mm, even if removable parts or fully open doors protrude into the escape route
- Switchgear panel or cubicle doors should close in the direction of escape
- For mounting and maintenance work behind enclosed units (stand-alone) a passage width of 500 mm is sufficient
- A minimum height of 2,000 mm below ceilings, covers or enclosures, except for cable basements is required
- Exits must be arranged in such a way that the length of the escape route inside the room does not exceed 20 m in case of rated voltages up to 52 kV. This requirement does not apply to walk-in busbar or cable conduits or ducts
- For installations with a rated voltage up to 52 kV, the length of the escape route inside the room must not exceed 20 m (40 m for installations above 52 kV)
- Fixed ladders or similar facilities are permissible as emergency exits in escape routes

**Accessibility of compartments**

The IEC 62271-200 (VDE 0671-200) standard for metal-enclosed switchgear distinguishes between accessibility level A for authorized personnel and accessibility level B for unlimited access (also for the general public). In addition to this, the opening possibilities of a compartment are distinguished, which influences the accessibility, and thus the availability, of a switchgear.

A gas-insulated switchgear is also available as a type with

- Non-accessible compartment  
It must not be opened. Opening such a compartment could destroy it and impair functioning of the switchgear

Medium-voltage switchgear are further differentiated according to three opening types:

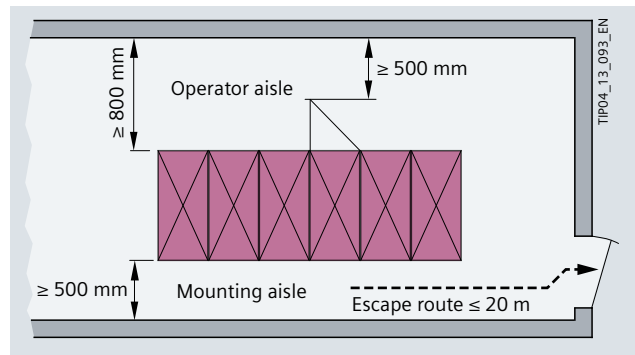

Fig. 8/4: Installation of switchgear in acc. with IEC 61936-1 (VDE 0101-1)

- Interlock-controlled accessible compartment  
an interlock in the the panel grants access when live parts are isolated and earthed. Opening the switchgear under normal operating conditions or for maintenance, for example to replace HV HRC fuses, is possible
- Process-dependent accessible compartment  
access is described through instructions of the operating company, and a lock shall ensure safety of access during normal operation and maintenance
- Tool-dependent accessible compartment  
tools and precise work instructions are needed to open the compartment, for example including a safety note. This kind of accessibility shall not be usable during normal operation or maintenance

**Service continuity during work in progress**

IEC 62271-200 (VDE 0671-200) specifies categories of operational availability (LSC, loss of service continuity) of the functional units of a switchgear. They describe which parts must be put out of operation during the opening process of an accessible switchgear compartment. Accessibility of switches and terminals is categorized according to Tab. 8/2.

Fig. 8/5 shows some examples for the different categories of service continuity.

**Busbar systems**

The following aspects play a part when choosing a single or double busbar:

- The number of outgoing and incoming feeders
- Separate operation of parts of the installation required
- Operability of certain installation parts required during maintenance work in progress
- Switch-over of consumers to different feed-in sections
- Non-interruptible switch-over required

Category of service continuity	When an accessible compartment of the switchgear is opened ...	Type of construction
LSC 1	the busbar and therefore the complete switchgear must be isolated	No partition plates within the panel, no panel partitions to the adjacent panels
LSC 2	LSC 2A only the supply cable must be isolated. The busbar and the adjacent panels can remain in operation	Panel partitions and isolating distance with compartmentalization to the busbar
	LSC 2B the supply cable, the busbar, and the adjacent panels can remain in operation	Panel partitions and isolating distance with compartmentalization to the busbar and the cable

Tab. 8/2: Categories of service continuity

[back to page 170](#)

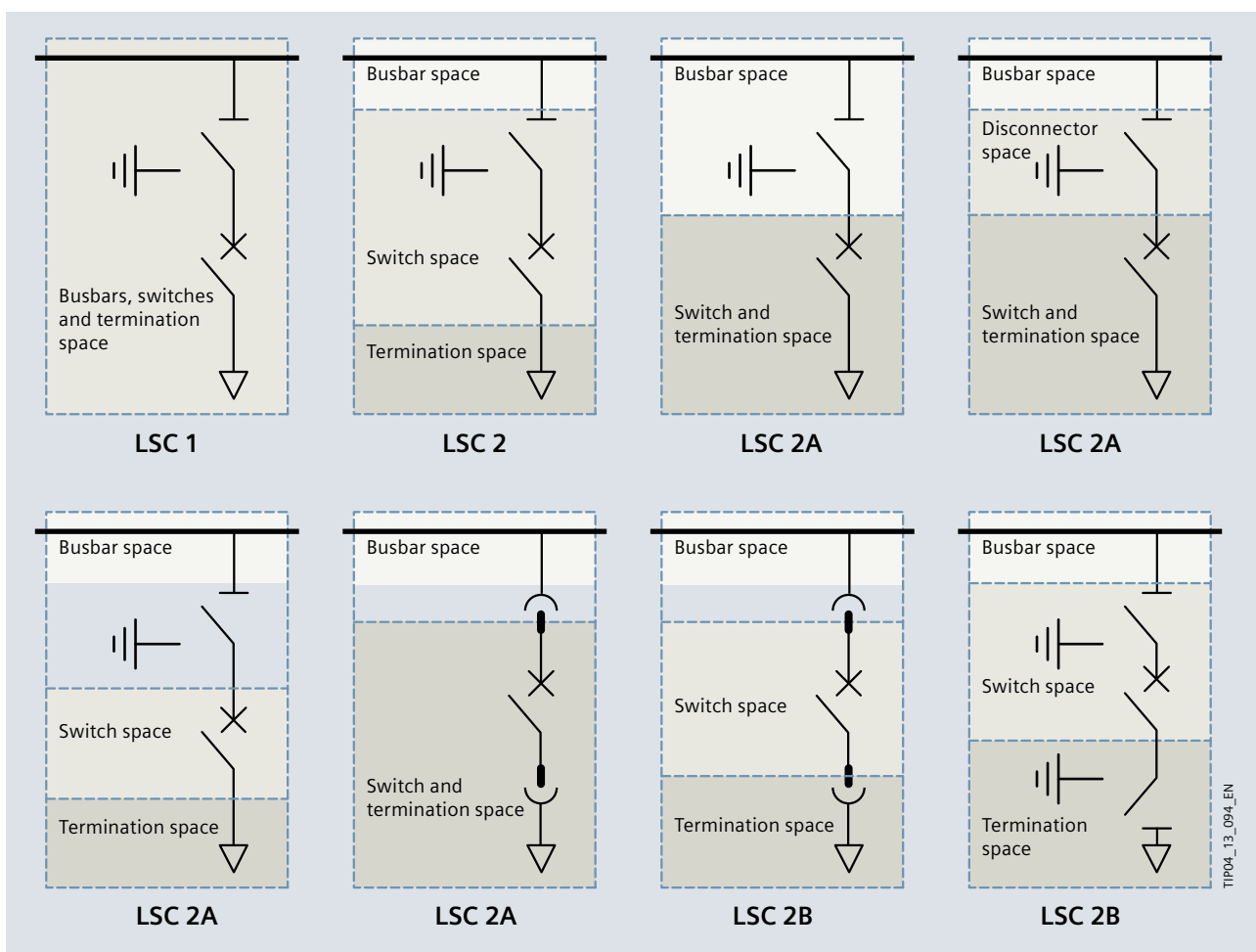

Fig. 8/5: Example for the service continuity (LSC) of switchgear

[back to page 170](#)

**Single busbar**

A single busbar is sufficient for most supply tasks, even if this supply task consists of two incoming feeders. It is straightforward and easy to handle, which reduces the likelihood of switching faults. When fault-affected switching operations happen, circuit-breakers only must be operated. If the wrong breaker should be operated inad-

vertently, this would not have any safety-relevant consequences in the switchgear, since circuit-breakers are capable of making and breaking all load and short-circuit currents, even under earth-fault and other fault conditions.

In case of more intense branching (rule of thumb: more than five feeders), the single busbar can be subdivided

once or several times, with its own feed-in in every section. Disconnectors or switch-disconnectors at the interruption points create bus sectionalizers, whereas circuit-breakers create longitudinal busbar couplers (BCL). A BCL makes sense if the busbar sections are to be operated as alternately separated or coupled.

### Double busbar

Reasons for using a double busbar can be, for example:

- Two or more feed-in points must always be operated separately (for example because there are different suppliers, or embedded power generation is used separate from the public grid)
- Consumers with disturbing perturbations on the grid are separated from consumers placing high requirements on the power supply quality
- Consumers classified according to importance and assigned to service continuity requirements placed on the grids
- Limited short-circuit strength of already installed equipment requires a subdivision into two subsystems with switch-overs for load balancing in case of varying power demand

Apart from the first example, examples two to four allow the use of a transversal busbar coupler (BCT), which permits changing busbars without interrupting the energy flow (Fig. 8/6).

### Internal arc classification

A successful type test of medium voltage switchgear also requires an internal arc fault classification IAC in accordance with IEC 62271-200 (VDE 0671-200). The classification distinguishes as follows:

- Accessibility
  - A access for qualified personnel only
  - B public access (meaning a testing under tightened conditions)
- Qualified, accessible sides of the switchgear
  - F Front
  - L Lateral
  - R Rear
- Test current and duration

*Example: Internal arc classification*

*IAC AR BFL 25 kA 1 s*

The specification means that the rear side may only be accessed by qualified personnel, whereas the front and lateral sides may be accessed by anybody. The internal arcing test was made with a test current of 25 kA for a duration of 1 s.

*Note: Medium-voltage switchgear are generally tested for accessibility of Type A. Only complete, factory-assembled stations (transformer/load-centre substations) are tested for Type B. Testing normal switchgear for conformance with Type B doesn't make sense, since they will always be built into an additional station housing in public spaces.*

Considering the hazards involved in the occurrence of an arc fault, the following aspects should be noted when configuring on the basis of the IEC 61936-1 (VDE 0101-1) standard:

1. Protection against operator faults, for instance ensured by the following measures:
  - Switch-disconnectors instead of disconnectors
  - Make-proof switches
  - Locking devices
  - Unambiguous key locks
2. Keep operating aisles as short, high and wide as possible
3. Use sealed encapsulations or covers instead of encapsulations with openings or meshed wire
4. Deploy installations which are arc-fault-tested instead of installations in open design (e.g. installations in accordance with IEC 62271-200; VDE 0671-200)
5. Bleed off arc gases into a direction away from the operator personnel, and if required, out of the building
6. Use current-limiting devices
7. Ensure very short tripping times from fast-acting relays or devices that respond to pressure, light or heat
8. Operate the installation from a safe distance
9. Prevent the re-energization by use of non-resettable devices which detect internal equipment faults, incorporate pressure relief and provide an external indication

According to this, the operating room must always be included in the protection measures to be taken against the effects of an arc fault:

- A calculation of the dynamic pressure load on the operating room, from which an architect or structural engineer may recognize the stress on building structures, is recommended
- The operating room must be equipped with pressure relief openings of sufficient cross section or with a pressure relief duct

Siemens provides two calculation methods as a service to establish rough guidance values for the calculation of the



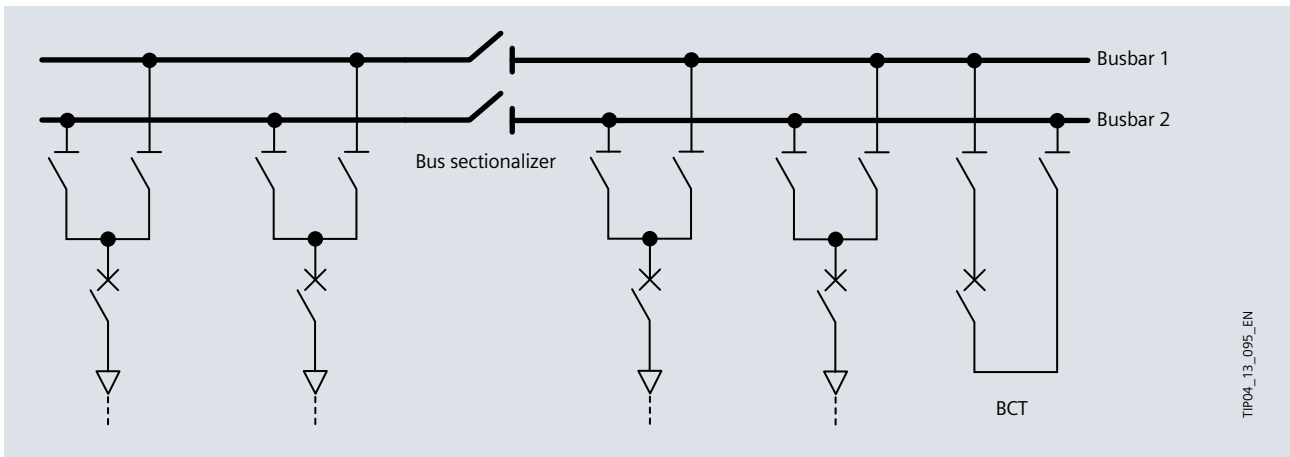

Fig. 8/6: Duplicate busbar with bus sectionalizer and busbar coupler, transversal (BCT)

[back to page 172](#)

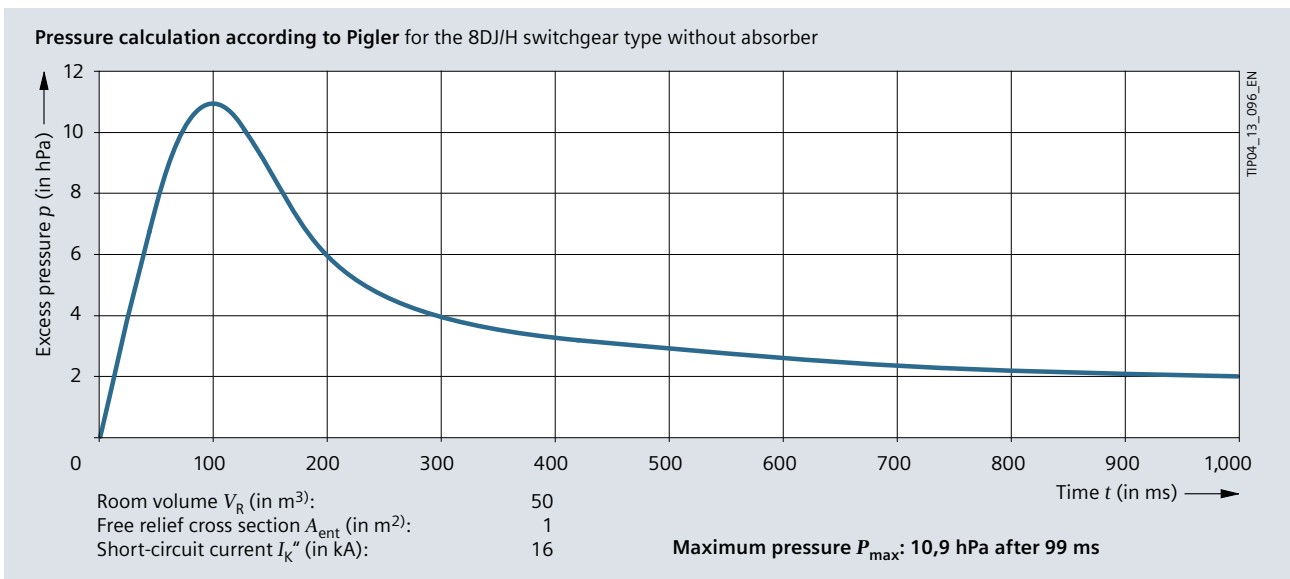

Fig. 8/7: Example of stationary excess pressures resulting from internal arc faults

room size and/or pressure relief openings during the planning phase.

### Estimation of pressure effects according to Pigler

A simple method provides the estimation according to F. Pigler [10] for rooms up to 50 m<sup>3</sup>. The calculation can be performed by a TIP contact person ([siemens.com/tip-cs/contact](https://www.siemens.com/tip-cs/contact)) when 8DJH medium switchgear is used. Data on the room volume, the area of the free relief cross section and the short-circuit current to be tested are entered into a matrix. This supplies a simple curve progression for the overload pressure (see Fig. 8/7).

- 1
- 2
- 3
- 4
- 5
- 6
- 7
- 8
- 9
- 10
- 11
- 12
- 13
- 14
- 15
- 16
- 17

### Finite-elements-simulation of pressure load under conditions of arcing

Although the incidence of an internal fault (arc fault) is very unlikely in type tested air- or gas-insulated switchgear, the consequences of such an arc fault may be severe for the operating personnel as much as for the room itself. For this reason, appropriate measures in relation to the room situation must be provided for pressure relief, such as pressure relief outlets, ducts, absorbers or coolers. Possibly this must already be considered during the installation and room planning stage.

With the aid of ultra-modern finite element methods, pressure calculations can be performed in the entire three-dimensionally mapped space over the entire burning time of the internal arc. Siemens offers the service<sup>1</sup> – at extra cost (expense-related) – of a numerical calculation on the basis of a 3D volume model, where the real installation of the switchgear, pressure development, reflection, and arrangement of the pressure relief openings is taken account of. Various pressure load scenarios can be calculated

for specific switchgear types, short-circuit currents, and installation sites. Thus the customer benefits from extended planning security and a cost-optimised solution.

The flow conditions are defined as boundary conditions. Firstly, these are the switchgear steel sheets and secondly, the absorber sheets to be penetrated. At last, the pressure relief openings in the switchgear room are defined. But the model also allows to calculate a fully enclosed room, or factor in pressure relief openings with a pre-defined response pressure. As a result, the model yields the pressure rise and the flow conditions at any point of the finite elements grid over time. Additionally, the pressure distribution on the walls can be shown as a contour plotting at a certain point in time (Fig. 8/8).

*Note: Typically, the overpressure caused by an arc fault, when assuming the same room volume, is significantly higher for air-insulated switchgear than for metal-enclosed, gas-insulated switchgear.*

<sup>1</sup> For any information or requests in this matter, please turn to your TIP contact: [siemens.com/tip-cs/contact](http://siemens.com/tip-cs/contact)

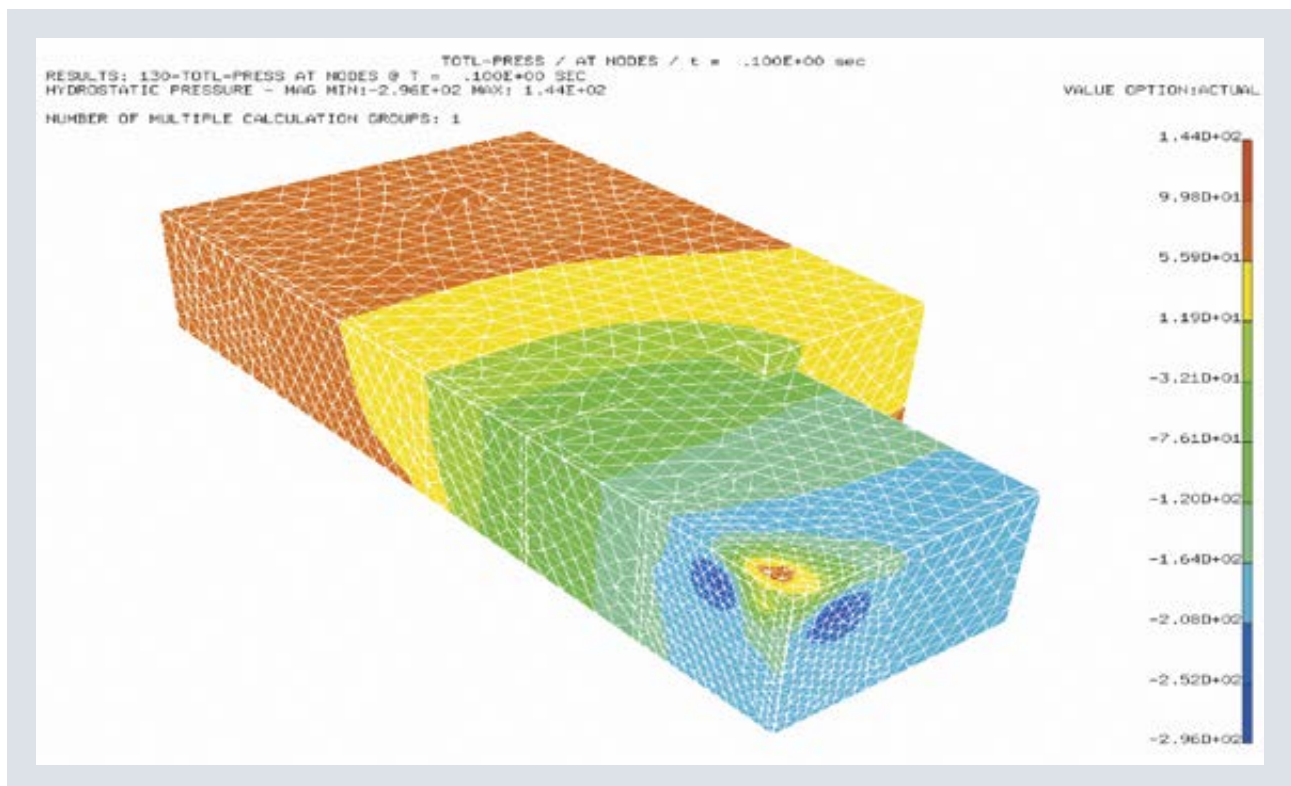

Fig. 8/8: Contour plotting of a simulation at the point 0.1 s

## 8.2 Medium-Voltage Switching Devices

Switching devices encompasses devices for closing (making) or opening (breaking) circuits. The following loads can occur during making and breaking:

- No-load switching
- Switching of operating currents
- Switching of short-circuit currents

Selection criteria can be:

- Operational switching capacity
- Fault current switching capacity
- Switching frequency

Basic switching device requirements are:

- In closed condition, the switching device shall present a resistance to the flowing of operating and short-circuit currents which is as low as possible
- In open condition, the clearance between open contacts must safely withstand all voltages applied
- All live parts must be sufficiently earthed and insulated phase to phase when the switching device is open or closed
- The switching device shall be capable of closing the circuit when a voltage is applied. For disconnectors, this condition is only required in the power-off state with the exception of minor load currents
- The switching device shall be capable of closing the circuit when current is flowing. This requirement is not made for disconnectors
- The switching device shall cause switching overvoltages as low as possible

The individual devices, which will be introduced in the following, differ in terms of their mechanical and electrical endurance, their maintenance intervals and the maintenance expense. Additional criteria may be:

- The isolating distance  
In fixed-mounted switchgear, switching devices are required for creating this isolating distance. Switch-disconnectors meet the isolating distance requirement. Switches and circuit-breakers or contactors, however, do not meet this requirement. Contactors need an additional disconnecting device or equivalent unit. This does not play a part for switchgear with withdrawable units or trucks, since the isolating distance is there created by moving out the device of the switchgear
- The motorized operating mechanism  
Tasks such as synchronisation or the creation of (multiple) short interruptions require operating mechanisms with short on/off switching times. This calls for stored energy mechanisms; snap-action drives are not suitable

### 8.2.1 Switching Device Functions

- Circuit-breakers  
can make and break all currents within their rated value range; from small inductive and capacitive load currents through to the full short-circuit current. They can perform under all fault conditions in the system, such as earth fault, phase opposition, etc.
- Switches  
can switch currents up to their rated operating current and close on short circuit (up to their rated short-circuit making current)
- Disconnectors  
are used for de-energized making and breaking. It is their job to “isolate” devices connected in series so that work can be carried out on them
- Switch-disconnectors  
are a combination of switch and disconnector, i.e. load interrupter switch with isolating distance
- Contactors  
are load switching devices with limited short-circuit making or breaking capacity. They are used with large switching frequencies
- Earthing switches  
earth disconnected circuits
- Make-proof earthing switches (fault initiating switches with making capacity)  
are used for the safe earthing of circuits even when they are energized, i.e. also for the case where the circuit to be earthed has not been disconnected inadvertently
- Fuses  
consist of a fuse base and a fuse link. When the fuse link is withdrawn at zero current, the fuse base forms an isolating distance (as with disconnectors). The fuse link is used for the one-off breaking of a short-circuit current
- Surge arresters  
earth loads caused by lightning strikes (external overvoltages) or switching operations and earth faults (internal overvoltages). They therefore protect the connected equipment against impermissibly high voltages

## 8.2.2 Switching Device Selection

Switching devices are selected not only according to their rating data, but also according to the switching duties to be performed, which also includes the switching frequency. The following tables shall help categorize switching devices according to selection criteria (Tab. 8/3) and switching tasks (Tab. 8/4 to Tab. 8/9).

### Selection according to rating data

The power supply conditions, i.e. the properties of the primary circuit determine the required parameters. The most important ones are:

- **Rated voltage**  
is the upper limit of the line voltage for which the device is rated. As all high-voltage switching devices are zero-current interrupters – with the exception of some fuses – the line voltage is the most important dimensioning criterion. It determines the dielectric stressing of the switching device through transient and recovery voltage, especially when breaking

- **Rated insulation level**  
is the insulation strength of conductor to earth, between the conductors and across the opened breaker gap or across the isolating distance. The insulation strength is the capability of a device to withstand all voltages for a specified time up to the magnitude of the respective withstand voltage. These can be operating or high-frequency overvoltages caused by switching operations, earth faults (internal overvoltages) or lightning strikes (external overvoltages). The insulation strength is verified by a lightning impulse voltage test using the standard pulse wave 1.2/50  $\mu$ s (times for building up the lightning impulse voltage and its decline) and an alternating voltage test (50 Hz, 1 min)
- **Rated operating current**  
is the current that the main conducting path of a device can conduct under defined conditions. The temperature rise of components – especially contacts – may not exceed predefined values. Permissible temperature rises are always in relation to the ambient temperature. If a device is installed in an encapsulation, it may possibly not be operated with its full rated current, depending on how well the heat loss is dissipated

Device	Withstand capability, rated ...				Switching capacity, rated ...		
	Insulation level	Voltage	Operating current	Surge current	Breaking current	Short-circuit breaking current	Short-circuit making current
Circuit-breakers	x	x	x			x	x
Switch (disconnecter)	x	x	x		x		x
Disconnecter	x		x	x			
Earthing switch	x			x			
Make-proof earthing switch	x	x					x
Contactors	x	x	x	x		x <sup>1)</sup>	x <sup>1)</sup>
Fuse link		x	x			x	
Fuse base	x		x				
Surge arrester*	x <sup>2)</sup>	x <sup>3)</sup>		x <sup>4)</sup>		x <sup>5)</sup>	
Current limiting reactor	x		x	x			
Bushing	x		x	x <sup>6)</sup>			
Post insulator (insulator)	x			x <sup>6)</sup>			

x Selection parameter  
 1) Limited short-circuit breaking capacity  
 2) Applicable as selection parameter in special cases only, e.g. for exceptional pollution layer  
 3) For surge arresters with spark gap = rated voltage  
 4) Rated discharge current for surge arresters  
 5) For surge arresters short-circuit strength when there is an overload  
 6) For bushings and insulators: minimum failing loads for tension, bending, and torsion

\* Further selection criteria for surge arresters may also be: Residual voltage, rated discharge current, energy absorption capability, short-circuit strength (general), rated and continuous voltage (metal-oxide arrester), rated and response voltage (arrester with spark gap)  
 (Parameters of the secondary equipment for drives, control and monitoring are not taken into consideration in this table.)

Tab. 8/3: Device selection according to data of the primary circuit

- **Rated peak withstand current**  
is the peak value of the first large harmonic component of the short-circuit current during an initial response after the start of current flow which the device can conduct in a closed state. It is a dimension for the electrodynamic (mechanical) loading of an item of equipment. This quantity has no significance for devices with full making capacity (see 'Rated short-circuit making current')
- **Rated short-circuit making current**  
is the peak value of the making current for a short circuit at the connections of the switching device. The stressing is greater than for the rated peak withstand current, as dynamic forces may work against the movement of the contact pieces
- **Rated breaking current**  
is the load breaking current during normal operation. This quantity has no significance for devices with full breaking capacity and no critical current range (then the 'Rated short-circuit breaking current' should be used)
- **Rated short-circuit breaking current**  
is the r.m.s. value of the breaking current for a short circuit at the connections of the switching device

### Selection according to switching tasks

For a useful selection of switching devices, the switching tasks occurring during normal operation must be known, so that the optimal device can be selected in each individual case. It must be distinguished between

- undisturbed operation (Tab. 8/4 to Tab. 8/6) and
- operation under fault conditions (Tab. 8/7 to Tab. 8/9).

The following abbreviations and identifying characters are used in the tables:

- $I_{ma}$  rated short-circuit making current
- $I_{sc}$  rated short-circuit breaking current
- $I_r$  rated operating current
- $I_k''$  initial short-circuit alternating current
- $I_{an}$  motor starting current
- × component use makes sense
- component use doesn't make sense

Switching operation	Load case	cos φ	Current	Main problem	Comments								
						Circuit-breaker	Switch	Contact	Disconnect	Switch-disconnector	Earthing switch	Make-proof earthing switches	Fuse
Transformers	Non-loaded	<0.3	$\leq 0.03 I_r$	–	–	×	×	×	–	×	–	–	–
	Loaded	0.7–1.0	$\leq I_r$	–	Normally no protection circuitry necessary	×	×	×	–	×	–	–	–
	Overloaded	0.7–1.0	$\leq 1.2 I_r$	–	Normally no protection circuitry necessary	×	×	×	–	×	–	–	–
	Inrush	0.15	$\leq 15 I_r$	Current breaking up to $15 I_r$ with $\cos \varphi \leq 0.15$ overvoltage possible	Protection relay with rush stabilisation required	×	–	×	–	–	–	–	–
Furnace transformer		0.2–0.9	$\leq 2 I_r$	High switching frequency	Circuitry for the protection against overvoltages must be individually configured	×	–	–	–	–	–	–	–
Earth-fault coils		0.15	$\leq 300 \text{ A}$	–	Surge arresters are common	×	×	–	–	×	–	–	–
Compensating coils		0.15	$\leq 2,000 \text{ A}$	Transient recovery voltage with steep edge $\leq 6 \text{ kV/ms}$	Circuitry for the protection against overvoltages must be individually configured	×	×	–	–	–	–	–	–
Motors	In operation	0.8–0.9	$\leq I_r$	–	–	×	×	×	–	–	–	–	–
	Starting	0.2–0.3	$\leq 7 I_r$	Current breaking up to $7 I_r$ with $\cos \varphi \leq 0.3$	Normally no protection circuitry necessary	×	×	×	–	–	–	–	–
Generators		0.8–1.0	$\leq I_r$	Transient recovery voltage with steep edge	Overvoltage protection is common	×	–	–	–	–	–	–	–
Power converter transformer		0.1–1.0	$\leq I_r$	–	Overvoltage protection is common	×	–	–	–	–	–	–	–

Tab. 8/4: Switching tasks in inductive circuits during undisturbed operation

[back to page 176](#)

Switching operations during undisturbed operation

The precise meaning of the columns in Tab. 8/4 to Tab. 8/6 is:

- “cos φ”  
Guide values for the power factors present in the individual switching operations
- “Main problem”  
If nothing is specified, this switching condition is non-critical for the switching devices to be used
- “Current”  
Currents to be made or broken in the worst case:
  - the overloaded or stressed transformers do not include transformers with special loads such as motors, generators, power converters, and arc furnaces
  - In case of an earth fault, earth-fault windings may be faced with the full operating voltage at the open

contact gap even when the switching device is disconnected

- With compensating coils, a steep edge of the transient recovery voltage can be expected owing to the high natural frequency
- With frequently switched motors, it is more economically efficient to use contactors instead of circuit-breakers or switches
- Generators generally behave like an inductance, independent of the fact whether they are operated in an over- or under-excited state
- Filter circuits also include capacitors with current-limiting reactors
- Please note in Tab. 8/7 to Tab. 8/9 that the specified currents must be made or broken in the worst case in the event of a transformer-fed short circuit.

Switching operation	cos φ	Current	Main problem	Comments								
					Circuit-breakers	Switch	Contactor	Disconnecter	Switch-disconnector	Earthing switch	Make-proof earthing switches	Fuse
Capacitor banks	capacitive	≤ 1.4 I <sub>r</sub>	High recovery voltage	–	x	x	x	–	x	–	–	x
Filter circuits	capacitive	≤ 1,000 A	High recovery voltage	–	x	x	–	–	–	–	–	–
Paralleling of capacitor banks	capacitive	≤ 100 I <sub>r</sub>	High amplitude and steep edge of the making current	Permissible making current: ≤ 5 kA: for NXACT vacuum circuit-breaker ≤ 10 kA: for 3AH vacuum circuit-breaker > 10 kA: Reactor required	x	x	–	–	–	–	–	–
Unloaded cables	capacitive	≤ 100 A	High recovery voltage	–	x	x	–	–	x	–	–	–
Unloaded overhead lines	capacitive	≤ 10 A	High recovery voltage	–	x	x	–	–	x	–	–	–
Ripple control systems	capacitive	≤ 20 A	High recovery voltage	–	x	x	–	–	–	–	–	–

Tab. 8/5: Switching tasks in capacitive circuits during undisturbed operation

1

2

3

4

5

6

7

8

9

10

11

12

13

14

15

16

17

Switching operation	cos φ	Current	Main problem	Comments	Circuit-breaker	Switch	Contact	Disconnector	Switch-disconnector	Earthing switch	Make-proof earthing switches	Fuse
Ring separations	0.3 inductive	$\leq I_r$	-	-	x	x	x	-	x	-	-	-
Switch-over to differently loaded busbars	0.7 – 1.0 inductive	$\leq I_r$	-	-	x	x	x	-	x	-	-	-
Unloaded cables	-	-	-	-	x	-	-	x	x	x	x	-
Unloaded overhead lines	-	-	-	-	x	-	-	-	-	-	-	-
Ripple control systems	-	-	-	-	-	-	-	x	x	-	-	-

Tab. 8/6: Switching tasks in other operational cases

[back to page 178](#)

Switching operation	cos φ	Current	Main problem	Comments	Circuit-breaker	Switch	Contact	Disconnector	Switch-disconnector	Earthing switch	Make-proof earthing switches	Fuse
Activation	0.15 inductive	$I_{ma}$	-	-	x	x	-	-	x	-	x	-
Terminal short circuit	0.15 inductive	$I_{sc}$	-	-	x	-	-	-	-	-	-	x
Generator-fed short circuit	0.15 inductive	$I_{sc}$	Transient recovery voltage with steep edge $\leq 6$ kV/ms	Overtoltage protection for generators with $I_k'' \leq 600$ A	x	-	-	-	-	-	-	-
Short interruption	0.15 inductive	$I_{sc}$	-	-	x	-	-	-	-	-	-	-
Transformer-fed short circuit	0.15 inductive	$I_{sc}$	Transient recovery voltage with steep edge $\leq 4$ kV/ms	-	x	-	-	-	-	-	-	x
Short circuit current limiting coils	0.15 inductive	$I_{sc}$	Transient recovery voltage with steep edge $\leq 10$ kV/ms	-	x	-	-	-	-	-	-	-
Double earth fault	0.15 inductive	$\leq 0.87 I_{sc}$	-	-	x	-	-	-	-	-	-	x
Stalling motors	0.2 inductive	$\leq 6 I_r$	Current breaking up to $6 I_r$ with $\cos \varphi \leq 0.3$	For motors with $I_{an} \leq 600$ A suitable as protection circuitry: 3EF overvoltage limiter. Single-compensated motors do not need protection circuitry.	x	x	-	-	-	-	-	-
Phase opposition	0.15 inductive	$0.25 I_{sc}$	-	-	x	-	-	-	-	-	-	-

Tab. 8/7: Switching tasks in case of short circuit

[back to page 178](#)



Switching operation	cos φ	Current	Main problem	Comments	Circuit-breakers	Switch	Contactor	Disconnecter	Switch-disconnector	Earthing switch	Make-proof earthing switches	Fuse
Unloaded cables /overhead lines (supply-side fault)	capacitive	≤5 A	High recovery voltage	–	x	x	x	–	–	–	–	–
Loaded cables /overhead lines (supply-side fault)	variable	≤I <sub>r</sub>	High recovery voltage	–	x	x	x	–	–	–	–	–
Switching of the earth-fault current (load-side fault)	variable	≤I <sub>r</sub>	–	–	x	x	x	–	–	–	–	–

Tab. 8/8: Switching tasks under earth-fault conditions

Switching operation	cos φ	Current	Main problem	Comments	Circuit-breaker	Switch	Contactor	Disconnecter	Switch-disconnector	Earthing switch	Make-proof earthing switches	Fuse
Protection disconnecting circuitry (disconnecting under load)	0.7 – 1.0 inductive	≤I <sub>r</sub>	High recovery voltage	–	–	–	–	–	x	–	–	–
Rapid switch-over	0.7 – 1.0 inductive	≤I <sub>r</sub>	Switch-over in < 150 ms	–	x	–	–	–	–	–	–	–

Tab. 8/9: Switching tasks in other cases

[back to page 176](#)

### Selection according to endurance and switching frequency

If several devices satisfy the electrical requirements and no further criteria are more important, the required switching frequency can be used as an additional selection criterion. The following tables show the endurance of the switchgear and therefore provide a recommendation for their appropriate use. The respective device standards distinguish between classes of mechanical (M) and electrical (E) endurance, whereby they can also be used together on a switch; for example. A switch for example can have both: mechanical class M1 and electrical class E3.

Class C describes the capacitive switching behaviour, which summarizes switch behaviour during the switching of overhead lines, cables, and capacitors (single and parallel switching). C1 is sufficient for the switching of cables and overhead lines with a low switching frequency. C2 is required if capacitor banks and filters shall be switched, and also if switching frequencies of cables and overhead lines are high. C2 also applies to other capacitive switching tasks.

Class S indicates the network type (cable or overhead line) for which a circuit-breaker is to be used. Circuit-breakers in indoor switchgear are always categorized as Class S1, this means a cable network. This is also true for overhead line branches, since they are connected to the switchgear by means of a cable.

### Circuit-breakers

IEC 62271-100 (VDE 0671-100) defines the mechanical endurance with precise switching cycle figures (M class), whereas the electrical endurance (E class) is only characterized by the verbal attributes as “basic” (Class E1) and “extended” (Class E2). For better orientation, Tab. 8/10 indicates the switching cycle figures for Classes E1 and E2, which modern vacuum circuit-breakers are usually capable of handling today.

The respective number of switching operations with the rated short-circuit breaking current  $I_{sc}$  in Tab. 8/10 corresponds to the respective number of switching sequences in accordance with the type tests. Modern vacuum circuit-breakers can usually make and break the rated operating current with the number of mechanical switching cycles.

### Switches

IEC 62271-103 (VDE 0671-103) only specifies classes for the so-called multi-purpose load interrupter switches. In addition, there are “special purpose switches” and “limited purpose switches”. General purpose switches must be able to switch different types of operating currents (load currents, ring currents, currents of unloaded transformers, charging currents of unloaded cables and overhead lines) as well as make short-circuit currents. General purpose switches intended for use in systems with isolated neutral point or with earth-fault compensation, must also be able to switch under earth-fault conditions. Their versatility is reflected in the precise specifications that are made for Class E, the electrical endurance (Tab. 8/11).

Class		Description			
M	M1	2,000 switching cycles		Normal mechanical endurance	
	M2	10,000 switching cycles		Extended mechanical endurance, low maintenance	
E	E1	2 × C and 3 × O with 10%, 30%, 60% and 100% $I_{sc}$		Normal electrical endurance (switch which is not covered by E2)	
	E2	2 × C and 3 × O with 10%, 30%, 60% and 100% $I_{sc}$		Without automatic reclosing	Extended electrical endurance without maintenance of the switching chamber
		26 × C    130 × O    10% $I_{sc}$ 26 × C    130 × O    30% $I_{sc}$ 4 × C     8 × O     60% $I_{sc}$ 4 × C     6 × O     100% $I_{sc}$		With automatic reclosing	
C	C1	24 × O	every 10 ... 40% $I_{le}, I_{ce}, I_{bc}$	Low backfiring probability	Backfiring-free off-switching in 2 out of 3 test series
	C2	24 × O 128 × O	every 10 ... 40% $I_{le}, I_{ce}, I_{bc}$ every 10 ... 40% $I_{le}, I_{ce}, I_{bc}$	Very low backfiring probability	
S	S1	Circuit-breaker for use in a cable network			
	S2	Circuit-breaker for use in overhead line networks, or in a cable network with direct overhead line connection (without a cable between overhead line and breaker)			

Tab. 8/10: Endurance classes for circuit-breakers

- SF<sub>6</sub> switches are appropriate when the switching frequency is ≤ 1 time per month. These switches are usually classified as E3 with regard to their electrical endurance
- Air or hard-gas switches are only useful with switching frequencies ≤ 1 time per year. These switches are simpler and usually belong to the E1 class. Versions belonging to Class E2 are in between in terms of their switching frequency
- Vacuum switches Their performance is significantly above that of the M2/E3 classes. They are used for special tasks – mostly in industrial supply systems – or when the switching frequency is ≥ 1 time per week

*Disconnectors*

Disconnectors do not have any switching capacity. Disconnectors up to 52 kV may only switch negligible currents up to 500 mA (for example voltage transformers) or larger currents only when there is an insignificant voltage difference (e.g. for a busbar change with activated BCT). According to IEC 62271-102 (VDE 0671-102), only the classes for the mechanical switching cycles were therefore defined (Tab. 8/12).

*Earthing switches*

With earthing switches, the E classes designate the short-circuit making capacity (earth to applied voltage Tab. 8/13). E0 corresponds to a normal earthing switch. Switches of the E1 and E2 classes are also called make-

Class		Description		
M	M1	1,000 switching cycles	Mechanical endurance	
	M2	5,000 switching cycles	Increased mechanical endurance	
E	E1	10 × I <sub>load</sub> 10 × I <sub>loop</sub> 2 × I <sub>ma</sub>	20 × 0.05 I <sub>load</sub> 10 × I <sub>cc</sub>	Test currents: I <sub>load</sub> rated network load breaking current I <sub>loop</sub> rated ring breaking current I <sub>cc</sub> rated cable breaking current I <sub>lc</sub> rated overhead line breaking current I <sub>sb</sub> rated capacitor breaking current I <sub>bb</sub> rated parallel capacitor breaking current
	E2	30 × I <sub>load</sub> 20 × I <sub>loop</sub> 5 × I <sub>ma</sub>	10 × 0.02 to 0.04 I <sub>cc</sub> 10 × I <sub>lc</sub>	
	E3	100 × I <sub>load</sub> 20 × I <sub>loop</sub> 5 × I <sub>ma</sub>	10 × I <sub>ef1</sub> 10 × I <sub>ef2</sub>	
C	C1	10 × I <sub>cc</sub> 10 × I <sub>lc</sub> 10 × I <sub>sc</sub>	Low probability of restrikes (frequency not defined)	I <sub>ef1</sub> rated earth-fault breaking current I <sub>ef2</sub> rated cable and overhead line breaking current under earth-fault conditions
	C2	10 × I <sub>bb</sub> Additionally 10 times each 0.1 ... 0.4 × I <sub>cc</sub> , I <sub>sb</sub> , I <sub>bb</sub>	Very low probability of restrikes	I <sub>ma</sub> rated short-circuit making current

Tab. 8/11: Endurance classes for multi-purpose load interrupter switches

Class		Description	
M	M0	1,000 switching cycles	Standard version for general requirements
	M1	2,000 switching cycles	Extended mechanical endurance (M1 and M2 are not intended for individual disconnectors, but for a combination with circuit-breakers belonging to the same class)
	M2	10,000 switching cycles	

Tab. 8/12: Endurance classes for disconnectors

Class		Description	
E	E0	0 × I <sub>ma</sub> no short-circuit making capacity	For general requirements
	E1	2 × I <sub>ma</sub> short-circuit making capacity	For general requirements
	E2	5 × I <sub>ma</sub> short-circuit making capacity	Reduced maintenance required

Tab. 8/13: Endurance classes for earthing switches

1

proof earthing switches or high-speed earthing switches. The IEC 62271-102 (VDE 0671-102) standard does not specify how often an earthing switch can be actuated purely mechanically; there are no M classes for these switches.

2

3

*Contactors*

4

IEC 62271-106 (VDE 0671-106) has not defined any endurance classes for contactors yet. Commonly used contactors have a mechanical and electrical endurance in the range of 250,000 to 1,000,000 switching cycles. They are used wherever switching operations are performed very frequently, for example > 1 time per hour. The standard specifies two classes, C1 and C2, for the probability of restrikes:

5

6

- Class C1 (low probability of restrikes): up to 5 cumulated restrikes are permitted during the breaking of capacitive currents
- Class C2 (very low probability of restrikes): no restrikes

7

8

Testing references to the test switching cycles BC1 and BC2 for capacitor current from the IEC 62271-100 (VDE 0671-100) standard.

9

10

11

12

13

14

15

16

17

### 8.3 Medium-Voltage Protection

Protection relays with digital circuits for medium-voltage protection have a lot of advantages over electromechanical and electronic relays:

- Many functions being integrated in one device result in a compact design and low cost
- The self-monitoring options of the devices make them highly available and cause little maintenance expense
- Digital technology completely prevents the zero drift of characteristic measurement curves (owing to ageing effects, for example)
- Digital filtering in combination with optimised measuring algorithms provides a high measuring accuracy
- Data collection and data processing form the basis for many integrated additional functions such as load monitoring and event/fault recording
- Simple and ergonomically friendly handling by means of membrane keypads, user-configurable function keys, and display
- Manifold interfaces support user-friendly communication from the PC or remote-controlled, for example
- Standardised communication protocols allow for interfacing to higher-level control systems

- Software-controlled parametrisation and functionality integration ensure maximum flexibility in use and integrated engineering

#### Method of operation of digital relays

In the process of digitalizing analogue-measured current and voltage values, measurements are first electrically isolated from the secondary circuit with the aid of an input transducer. Then, the measurement signal is analogue-filtered and amplified. The A/D signal transducers generate digital measured quantities from the analogue signal (Fig. 8/9). In dependency of the protection principles, the scan rate is between 12 and 20 signals per period. For critical devices, the scan rate is continuously adjusted as a function of the actual network frequency. The computer transmits a trigger command if applicable.

#### Modular design

A flexible system architecture, multi-functional design, and powerful as well as reliable communication options of protection devices are becoming more and more important in the face of changing network configurations and work-

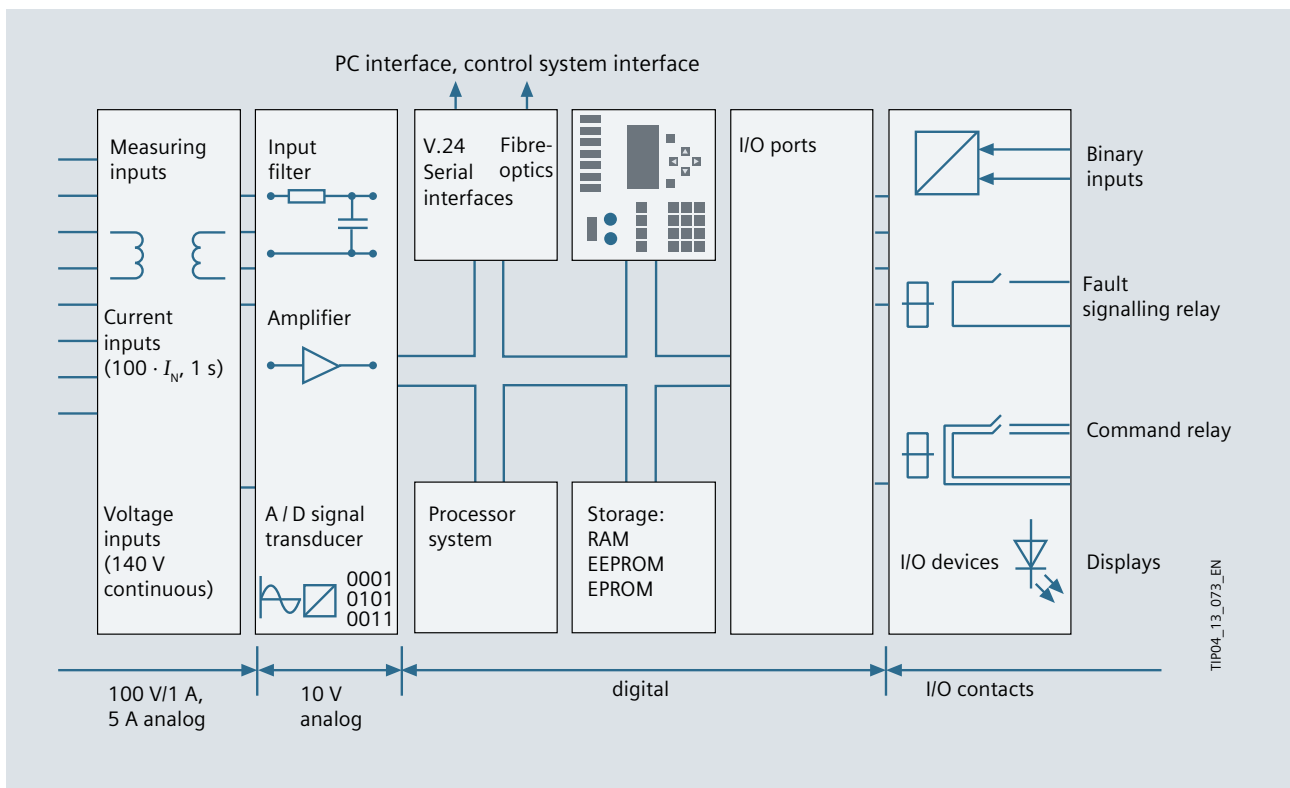

Fig. 8/9: Block diagram for a digital protection device

flows. For the new SIPROTEC 5 system (Fig. 8/10), this is subsumed under the terms of “holistic workflow”, “perfectly tailored fit”, “designed to communicate”, “safety and security inside”, and “smart automation”.

#### *Holistic workflow*

- Integrated system and device engineering – from the single line to device parameterisation
- Easy and intuitive graphical linking of primary and secondary systems
- Application templates included for frequently-used applications
- Manufacturer-independent tool for easy system engineering
- Libraries for user-created configurations and system parts
- Multi-user concept for parallel engineering
- Open interfaces for seamless integration into your process environment
- User interface developed and tested together with numerous users
- Integrated tools for testing during engineering, commissioning, and for the simulation of operating scenarios such as line faults or switching operations

#### *Perfectly tailored fit*

- Modular system design in hardware, software, and communications perfectly tailored to user needs
- Functional integration of a great variety of applications such as protection, control, measuring, power quality or fault recording
- Identical extension and communication modules for all device members in the family
- Innovative terminal technology ensures easy mounting and replaceability combined with maximum safety
- Identical functions throughout the entire system family, for example an identical automatic reclosing function of the 7SD8, 7SA8, 7SL8 line protection devices, reduce the training expense, thus enhancing the safety
- All functions can be individually edited and adapted to user requirements
- Innovations are available to all devices at the same time and can easily be retrofitted via libraries if required

#### *Designed to communicate*

- Adaptation to the topology of a given communication structure (ring, star, network, etc.) through parameters
- Scalable redundancy of hardware and software (protocols) matching application requirements
- Several communication channels to higher-level systems
- Pluggable communication modules suitable for retrofitting



Fig. 8/10: SIPROTEC 5 product family

- Hardware modules decoupled from the communication protocol applied
- Two independent protocols on one module
- Comprehensive routines for testing communication links, functions, and operational workflows

#### *Safety and security inside*

Tried and tested functions for system protection and personal safety, continuously further developed over five generations

- Long-life, robust hardware (housing, assemblies, connectors), and a sophisticated layout of the entire electronics for maximum strength in terms of voltage, EMC, climate, and mechanical load
- Sophisticated self-monitoring routines identify and report device malfunctions immediately and reliably
- Conforming to the strict cybersecurity requirements on the basis of user guidelines and standards such as the IEC/TS 62351 group of standards, the BDEW White Paper “Requirements for Secure Control and Telecommunication Systems” [11] and NERC CIP standards (North American Electric Reliability Corporation – Critical infrastructure protection)
- Encryption of the entire communication path between DIGSI 5, the device and system engineering tool by Siemens, and devices according to the recommendations of the IEC/TS 62351 group of standards

- Automatic logging of access attempts and security-critical handling performed at devices and systems

*Designed to communicate*

- Open and scalable architecture for IT integration and new functions
- Latest communication and cybersecurity standards implemented
- “Smart” functions, for example for power system operation, fault or power quality analyses (power system monitoring, power control unit, fault localisation)
- Integrated automation using optimised logic modules based on IEC 61131-3
- High-precision detection and processing of process parameters and transmission to other components in the smart grid
- Protection, automation, and monitoring in the smart grid

**Safety coordination**

The tripping characteristics and associated settings of the protection device must be carefully matched to attain selectivity. The main goal is to disconnect the faulty component as fast as possible, keeping the remaining network in operation so that interruptions of supply will be minimised and the network stability is not put at risk. Protection should be set as sensitive as possible in order to be able to detect faults even with the least possible current intensity. At the same time, it should remain stable under the permitted load, overload, and let-through conditions.

In order to attain selective short-circuit protection in the medium-voltage grid, the value for phase current excitation  $I >$  of the digital protection device should be set in such a way that the minimum short-circuit current trips a circuit-breaker, the maximum operating current, however, is carried without tripping.

$$f_B \cdot I_{B,max} \leq I > \leq \frac{I_{k,min}}{f_{LB}}$$

Where

- $I_{B,max}$  = Maximum operating current
- $f_{B,max}$  = Safety factor to allow for influences caused by operational changes and variations such as load changes, operation under faulted loads, transducer faults, relay resetting ratio; for example  $f_{B,max} = 1.7$  for cables,  $f_{B,max} = 2.0$  for transformers<sup>1)</sup>

<sup>1)</sup> When determining the safety factor, the coordination with the subordinate low-voltage grid must be kept in mind. This may result in higher  $f_{B,max}$  values (see chapter 7.7)

- $I_{k,min}$  = Minimum short-circuit current
- $f_{LB}$  = Safety factor for excitation linked to arc damping (typically between 1.25 and 2)

The type of neutral-point connection in the medium-voltage grid must be considered for earth-fault protection (see chapter 4). Furthermore, low-ohmic neutral point earthing can be distinguished according to protection function in terms of the earth current excite condition. For details please refer to [2]. For every protection disconnection, the total disconnect time  $t_{ag}$  must be less than or equal to the permissible total disconnect time  $t_{ag,perm}$ :

$$t_{ag} \leq t_{ag,perm}$$

A shorter total disconnect time limits the energy, thus permitting higher short-circuit currents. In order to keep damage and equipment load low in case of a short circuit, the total disconnect time should be restricted to the rated short time  $t_{thr}$  of equipment:

$$t_{ag} \leq t_{thr}$$

Active protection devices such as devices for overcurrent protection, busbar protection, or distance protection are called protection systems in contrast to passive protection devices (fuses, current limiters). There are special devices for transformer or generator protection. The devices common in the infrastructure sector will be described briefly below.

*Time-overcurrent protection*

Time-overcurrent protection devices detect a fault on account of its amperage and clear the fault after a certain delay time has elapsed. Time-overcurrent protection devices either work with current-independent current thresholds (DMT – definite time overcurrent protection) or with a current-dependent tripping characteristic (IDMTL – inverse definite minimum time leakage). The following should be taken into account for the selection of an appropriate protection device as main protection:

- Network configuration
- Neutral-point connection
- Type and size of the item of equipment to be protected

Normally, time-overcurrent protection devices acting as main protection should only be used for high-voltage motor ratings up to 2 MW and for transformer ratings up to 10 MVA. Above this, directional comparison protection devices should be used as main protection and time-overcurrent protection as standby protection. Both DMT (Fig. 8/11a) and IDMTL can be used for the protection of spur cables and normally open cable rings. With motors, DMT is used for short-circuit protection (Fig. 8/11b). Modern digital DMT devices provide more motor protection functions such as overload protection. So-called “thermo-boxes” can be used to sense and monitor the temperatures of critical spots in the motor (for example the bearings). This increases the sensibility of thermal overload protection. In conjunction with transformer protection (Fig. 8/11c), the high-current level  $I_{>>}$  acts as instantaneous short-circuit protection at the transformer’s high-voltage side and the overcurrent level  $I_{>}$  as standby protection for the low-voltage side. The additional function of “thermal overload protection” protects against continuous overloading of the transformer.

Time-overcurrent protection is the main protection function of the SIPROTEC 7SJ6 and 7SJ8 device series. It can be switched on and off separately for phase and earth currents. The 7SJ6 and 7SJ8 device series offer a choice between DMT and IDMTL tripping characteristics (Fig. 8/12).

Both the high-current level  $I_{>>}$  and the overcurrent level  $I_{>}$  always work with a current-independent tripping delay time (DMT). Different tripping characteristics can be set for the IDMTL function ( $I_p$  level). The characteristics (Fig. 8/13) are described by characteristic formulas (Tab. 8/14). The characteristic curve types for relay tripping times required in IEC 60255-151 (VDE 0435-3151) are identified by the letters A, B, C, D, E, and F.

Depending on the protection relay design, the directional XDMT protection function (XDMT representing IDMTL or DMT) can determine the direction of current flow from the phase displacement of current and voltage. In relation to this, it provides additional directional high-current and overcurrent levels. This allows setting different current thresholds and delay times for both directions (see chapter 4). Main applications are parallel lines as well as lines supplied from both sides.

Directional time-overcurrent protection using directional XDMT relays is applied for lines supplied from both ends, as they occur in double spur lines and in closed ring networks. For this purpose, protection is graded “device against device” beginning at the two feed-in units. At each of the outer ends, a non-directional XDMT relay is sufficient.

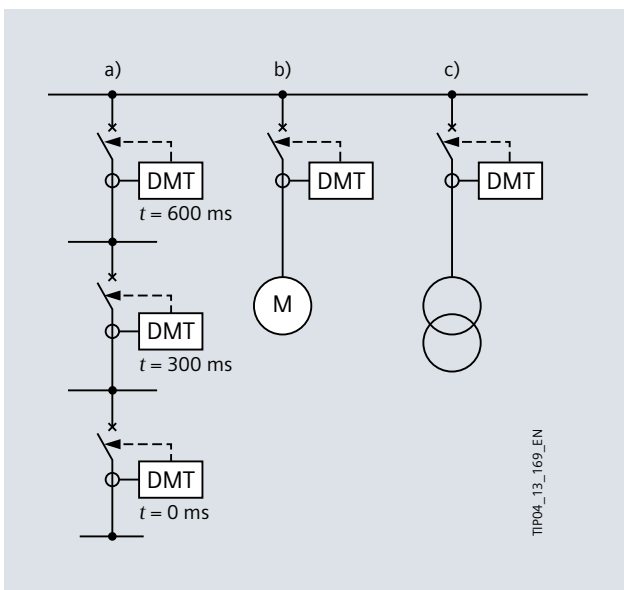

**Fig. 8/11: Main applications for DMT:**  
 a) Line protection  
 b) Motor protection  
 c) Transformer protection

Dependent time response for overcurrent relays	
A: Inverse	$t = \frac{0.14}{(I/I_p)^{0.02} - 1} \cdot T_p$
B: Greatly inverse	$t = \frac{13.5}{(I/I_p) - 1} \cdot T_p$
C: Extremely inverse	$t = \frac{80}{(I/I_p)^2 - 1} \cdot T_p$
D: IEEE moderately inverse	$t = \left[ \frac{0.0515}{(I/I_p)^{0.02} - 1} + 0.114 \right] \cdot T_p$
E: IEEE very inverse	$t = \left[ \frac{19.61}{(I/I_p)^2 - 1} + 0.491 \right] \cdot T_p$
F: IEEE extremely inverse	$t = \left[ \frac{28.2}{(I/I_p)^2 - 1} + 0.1217 \right] \cdot T_p$
$t$ tripping time $T_p$ set value of time multiplier	$I$ fault current $I_p$ current set value

**Tab. 8/14: Formulas for tripping characteristics acc. to IEC 60255-151 (VDE 0435-3151)**



In case of single-side feed-in using parallel lines, a fault in one line is also fed from the parallel line and thus per reverse power feed from the remote end. A directional XDMT protection function can quickly break the fault current flowing against the supply direction, since this cannot be an operating current.

To implement directional comparison protection, there must be a communication link between the directional XDMT relays placed at the beginning and end of a line section (see chapter 4). Should these relays receive an information from their respective "partner" relays that they recognize the fault in forward direction, the line fault located in between can be cleared instantaneously. And vice versa, if the fault is in "backward" direction and this is communicated to the partner, the partner relay can block the directional instantaneous trip level and the protection function can work with "normal" grading time.

Differential protection

If XDMT devices do not act selectively, or very short tripping times are required, differential protection is a good solution. The basis for this are the comparison and determination of differences of measured quantities at the two ends of a network section under consideration. With respect to differential protection, three different relay types will be briefly introduced below, distinguished by their protection function and area of application:

- Line differential protection 7SD
- Transformer differential protection 7UT
- Machine differential protection 7UM

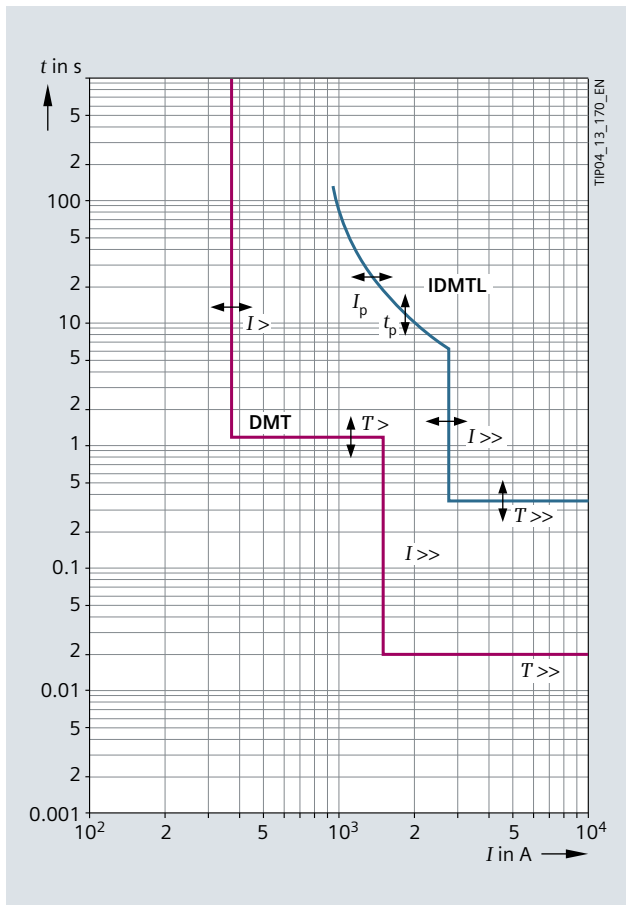

Fig. 8/12: Typical characteristics of DMT and IDMTL protection devices [back to page 188](#)

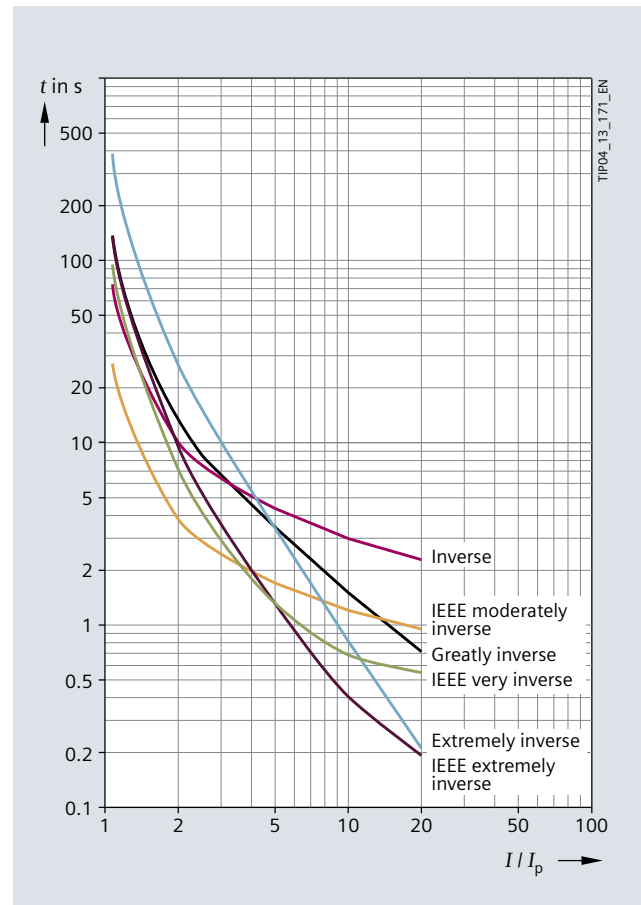

Fig. 8/13: Tripping characteristics acc. to IEC 60255-151 (VDE 0435-3151) [back to page 188](#)

1

2

3

4

5

6

7

8

9

10

11

12

13

14

15

16

17

The line differential protection function (ANSI 87L) of the 7SD6 (SIPROTEC 4) or 7SD8 relays (SIPROTEC 5 or SIPROTEC Compact) detects short circuits – even weak-current or high-ohmic ones – in the section to be protected by means of a phase-selective comparison of current values measured separately at the two ends of the line by separate devices (Fig. 8/14 a). Owing to the strictly local selectivity – the protection zone is limited by the current transformers at the two ends of the line section – network topology and voltage level have no effect in this context. Furthermore, the star-point conditioning of the current network is of no significance as current comparison takes place per phase and thus variable weightings for different faults – as they occurred in the conventional summation current transformer differential protection process – are nowadays unimportant.

Due to its strict selectivity, differential protection is generally set as instantaneous main protection, since no other protection measure can disconnect the line more quickly and selectively. Every 7SD610 compares the locally measured current values with the measured values of the opposite end and decides autonomously whether a line fault is present or not. A communication link is required to exchange measured values between the two devices.

The SIPROTEC differential protection relay of the 7UT6 and 7UT8 series can be used as an autonomous current comparison protection device for power transformers

(Fig. 8/14 b). As the feeding line lengths of the current transformers at the high- and low-voltage sides are usually not too long, the summated current can be formed in one device, and not in separate devices as in line differential protection. To this end, secondary-side adaptive circuits are no longer required to map current influences caused by the transformer, since the digital protection device does this by computation:

- Transmission ratio of transformer – by amplitude adjustment
- Phase shift of secondary currents – by vector group adjustment
- Possible misrepresentation of earth currents – by zero-current elimination, respectively zero-current correction

Additional protection by current comparison applicable for high-voltage motors in performance category  $P_{rM}$  greater than 2 MW or generators in performance category  $P_{rG}$  greater than 1 MW can be implemented by the SIPROTEC 7UM62 differential protection relay (Fig. 8/14 c and d).

#### Busbar protection

In switchgear installations, busbars are the places where the highest energy levels are concentrated. They are subject to a tremendous short-circuit load, as – for reasons of selectivity – the high short-circuit and earth-fault currents

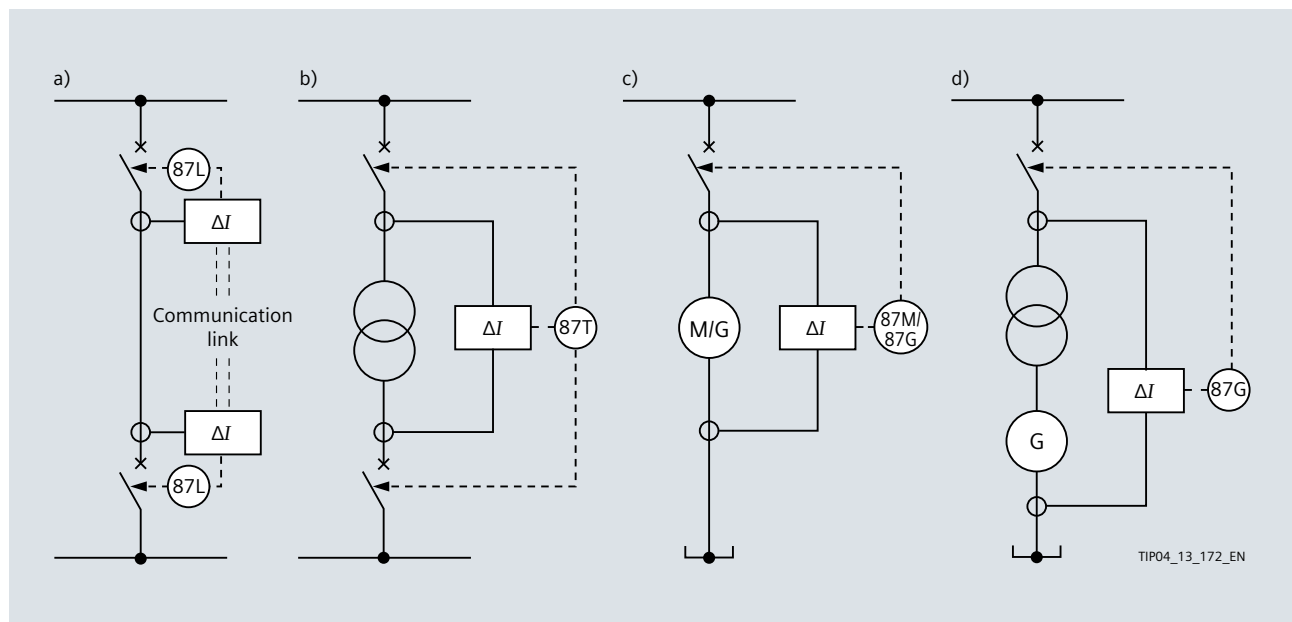

Fig. 8/14: Block diagrams for a) line differential protection  
 b) transformer differential protection ( $S_{rT} > 10$  MVA)  
 c) motor/generator differential protection ( $P_{rM} > 2$  MW/ $P_{rG} > 1$  MW)  
 d) generator blocking protection ( $P_{rG} > 1$  MW)

at the busbar result in long tripping times of the XDMT protection devices. Faults present too long can easily cause damage in the primary distribution system. For this reason must important busbars be protected quickly – independent of their voltage level.

In the face of the complexity of the busbar system (ranging from single to 5-fold busbars), busbar protection can get very complex. The principle of reverse interlocking (see chapter 4) is suitable for simpler configurations. Here, the DMT protection function of the feed-in trips quickly independent of the grading time, unless its quick-trip unit is not blocked by the short-circuit or earth-fault excitation in a feeder. In the feeder units, this excitation is parametrized to a special contact and all excitation contacts are connected in parallel.

A protection excitation in a feeder panel (fault F1 in Fig. 8/15) means that the fault present is not within the busbar area. Owing to the excitation of the feeder protection function, the (almost) instantaneous tripping  $I \gg$  of the feed-in protection ( $t \gg = 50$  ms in Fig. 8/15) can be blocked by the binary input. Here, feed-in protection acts as standby protection which trips with  $t >$ . If only the protection device for the feed-in is excited during a busbar fault (fault F2) with  $t >$  and  $t \gg$ , this blocking is suppressed and a trip is effected quickly on account of a busbar fault. This quick trip reduces the load applied by the fault.

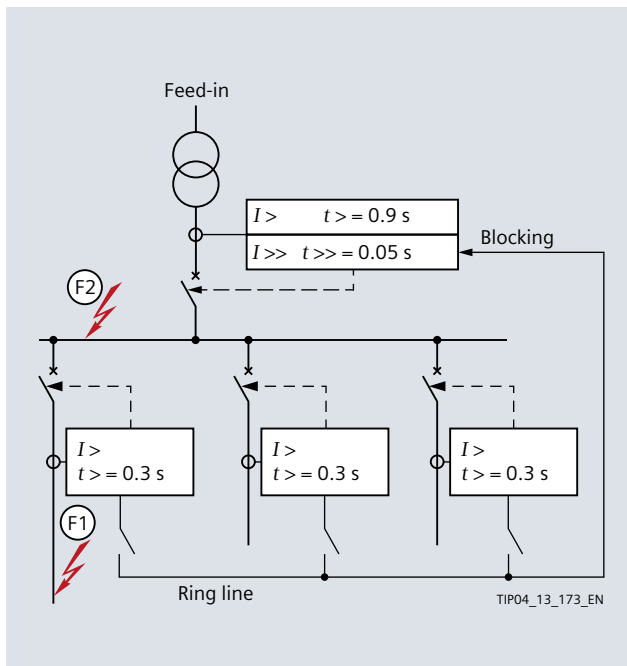

Fig. 8/15: Busbar protection by reverse interlocking for the single busbar

In case of a complex topology, the busbar protection device must also detect the disconnector situation in addition to the currents of each branch circuit and determine the selective zones from this, which makes protection very intricate.

Distance protection

The short-circuit impedance is a measured quantity which is proportional to the distance between the mounting location of the protection device and the fault location. For this reason, the impedances of the six possible fault loops established from all of the detected current and voltage values (Fig. 8/16) are compared to the line impedance in order to provide distance protection. After the delay time defined for each zone has elapsed, the distance protection function trips and clears the fault.

Distance protection is a universal short-circuit protection which is preferably used for cable and line monitoring. The distance protection function can be used in combination with various excitation methods:

- Overcurrent excitation
- Voltage- and current-dependent excitation
- Voltage, current- and phase-angle-dependent excitation
- Impedance excitation

The communication possibilities are identical for distance and line differential protection.

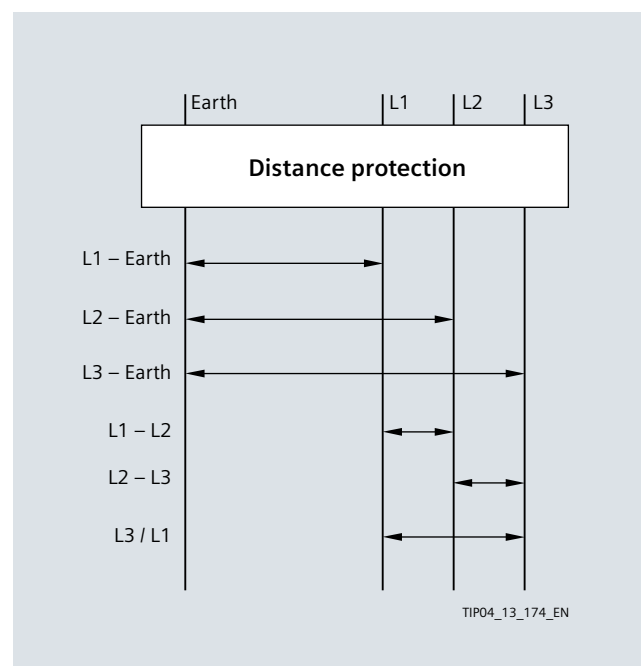

Fig. 8/16: Fault loops checked by the distance protection device

Con-  
tents

Intro-  
duction

1

2

3

4

5

6

7

**8**

9

10

11

12

13

14

15

16

17



# Chapter 9

## Transformers

9.1	Electrical Design	194
9.2	Losses and Profitability Estimates	197
9.3	Construction of Oil-immersed Transformers	199
9.4	GEAFOL Cast-resin Dry-type Transformers	201
9.5	Power Converter Transformer	203
9.6	FITformer® REG – Regulated Distribution Transformer	204
9.7	Transformer Operation	206
9.8	Transformer Room	209

**TRANSFORMATEUR**

**4**

# 9 Transformers

1  
2  
3  
4  
5  
6  
7  
8  
9  
10  
11  
12  
13  
14  
15  
16  
17

Transformers are an essential component for power transmission and distribution. Their ratings originate from their area of application, their construction, the nominal power and the transformation ratio. Transformer types range from generator transformers to distribution transformers.

The IEC 60076 (VDE 0532-76) series of standards describes power transformers with the exception of the following transformers:

- Rating < 1 kVA for single-phase transformers
- Rating < 5 kVA for three-phase transformers
- Transformer without a winding with a rated voltage > 1 kV
- Measuring transducers
- Transformers for static inverters
- Vehicle transformers
- Autotransformer starters
- Testing transformers
- Welding transformers

In addition to this, distribution transformers up to 36 kV are distinguished as follows:

- Three-phase dry-type distribution transformers (called GEAFOL transformers in the following) in accordance with EN 50541-1 (VDE 0532-241) with natural cooling and two windings ranging from 100 kVA to 3,150 kVA three-phase
- Oil-filled three-phase distribution transformers (called oil-immersed transformers in the following) with natural cooling and two windings in accordance with EN 50464-1 (VDE 0532-221) and IEC 60076-7 (VDE 0532-76-7) ranging from 50 kVA to 2,500 kVA three-phase (833 kVA single-phase)

## 9.1 Electrical Design

### Nominal power and cooling

All information about the rating of transformers in this manual results from the product of the rated voltage (no-load voltage multiplied by the phase factor  $\sqrt{3}$  for three-phase systems) and the rated current of the line-side winding (for a multi-winding transformer at the middle tap, if several taps are available).

EN 50541-1 (VDE 0532-241) specifies the following ratings in kVA for GEAFOL transformers (preferred types are underlined):

100 – 160 – 200 – 250 – 315 – 400 – 500 – 630 – 800 – 1,000 – 1,250 – 1,600 – 2,000 – 2,500 – 3,150

EN 50464-1 (VDE 0532-221) specifies the following ratings in kVA for oil-immersed transformers (preferred types are underlined):

50 – 100 – 160 – 200 – 250 – 315 – 400 – 500 – 630 – 800 – 1,000 – 1,250 – 1,600 – 2,000 – 2,500 – 3,150

Concerning the cooling type, GEAFOL transformers require the indication of the coolant flow besides the indication of air as coolant (letter A) according to IEC 60076-11 (VDE 0532-76-11):

- N Natural
- F Forced

If additional ventilation is used to attain a higher normal output (GEAFOL Standard up to 150%, GEAFOL Basic up to 130%), AN/AF must be specified. This indicates that natural air is used for cooling up to the rated output, above this limit forced air cooling is applied. The type plate would then read as follows, for example:

- Rating 1,000 kVA in cooling type AN
- Rating 1,500 kVA in cooling type AF

In compliance with IEC 60076-2, oil-immersed transformers are also distinguished according to the natural (N) and forced (F) circulation of the coolant. Normally, four letters are used to indicate the type of cooling:

1st letter – internal coolant:

- O Mineral oil or synthetic fluid with fire point  $\leq 300^\circ\text{C}$  (in accordance with ISO 2529)
- K Insulating liquid with fire point  $> 300^\circ\text{C}$
- L Insulating liquid with no measurable fire point

2nd letter – internal coolant circuit:

- N Natural heat flow through cooler and windings
- F Forced circulation through cooler and thermal convection in the windings
- D Forced circulation through cooler and directed at least to the windings

3rd letter – external coolant:

- A Air
- W Water

4th letter – external coolant circuit:

- N Natural convection
- F Forced circulation

If different cooling types are applied in an oil-immersed transformer, this must be indicated on the type plate and the technical descriptions, for example ONAN/ONAF/OFAF.

There is a load limit for natural cooling. Above this limit, the transformer utilises a cooling system with pumps and fans in both circuits.

### Connections and vector groups

The connections of three-phase transformers are the wirings of the winding strands from the input or output side to a star, delta, or zigzag connection. These circuit diagrams and the corresponding vector diagrams are shown in Fig. 9/1. The vector group indicates the connection of two transformer windings and the code number for the phase relation of the voltage vectors. Circuits are designated by the following code letters:

- Star connection Y, y
- Delta connection D, d
- Zigzag connection Z, z

Capital letters indicate the circuitry of the high-voltage winding, small letters the circuitry of the low-voltage winding. Capital letters are put first in vector groups. If the star point of a winding is connected in star or zigzag connection, it is designated as YN or ZN, respectively yn or zn.

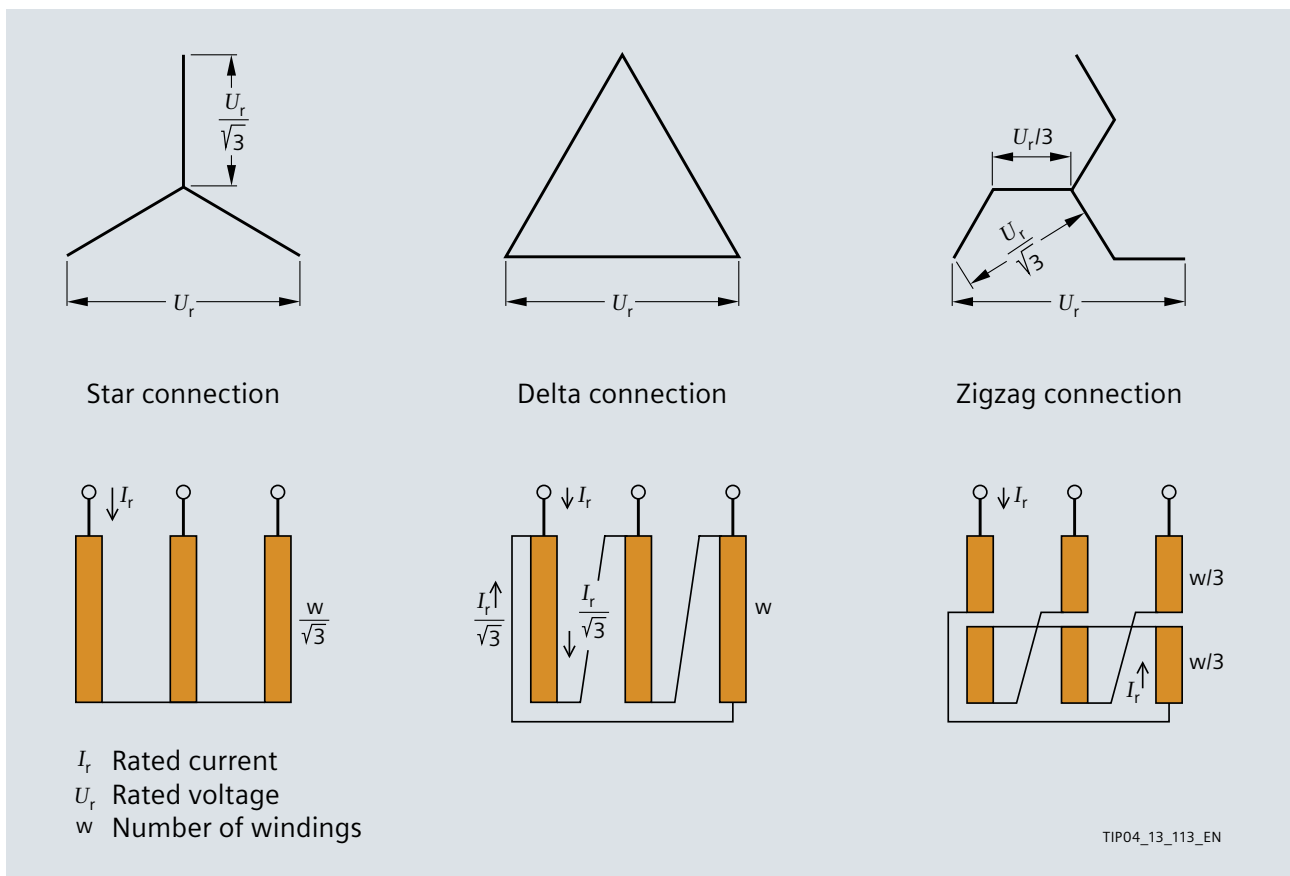

Fig. 9/1: Connections of three-phase current transformers with vector diagrams

- 1
- 2
- 3
- 4
- 5
- 6
- 7
- 8
- 9
- 10
- 11
- 12
- 13
- 14
- 15
- 16
- 17

The code number (0; 5 etc.) indicates in the vector diagram by which multiple of 30° the vector of the low voltage lags against the one of the high voltage with associated connection code. The direction of rotation of the vectors is anti-clockwise.

Typical vector groups are (see Fig. 9/2):

Yy0 (Yy6), Yz5 (Yz11), Dy5 (Dy11)

In transformers with these vector groups, a star point connected at the output side permits the connection of a neutral conductor in the three-phase distribution network. In this case, the vector group designations are as follows:

Yyn0 (Yyn6), Yzn5 (Yzn11), Dyn5 (Dyn11)

The star point of transformers with Yyn0 (Yyn6) vector groups can only be used for earthing or for a maximum load that doesn't exceed 10% of the rated current. Therefore, the Yyn connection is generally not suitable for the supply of distribution networks with a fourth, neutral conductor. One of the other vector groups listed above must then be configured. In a Yzn and Dyn connection, the star point can be loaded with 100% of the rated current.

In a zigzag connection, the current always flows through two leg windings from the conductor terminal to the star point terminal. The sub-voltages per leg always cover an angle of 120° in the three-phase system. Therefore, the voltage applied between the conductor terminals of the windings belonging to a phase is not twice the sub-voltage per leg, but only  $\sqrt{3}$  times the sub-voltage. For this reason, a zigzag connection requires more winding material (factor  $2/\sqrt{3}$ ) than a star connection.

In the delta connection, each leg requires more windings by a factor of  $\sqrt{3}$  compared to the star connection to attain the same voltage. Whereas the conductor cross section in the delta connection is smaller by a factor of  $1/\sqrt{3}$  compared to the star connection.

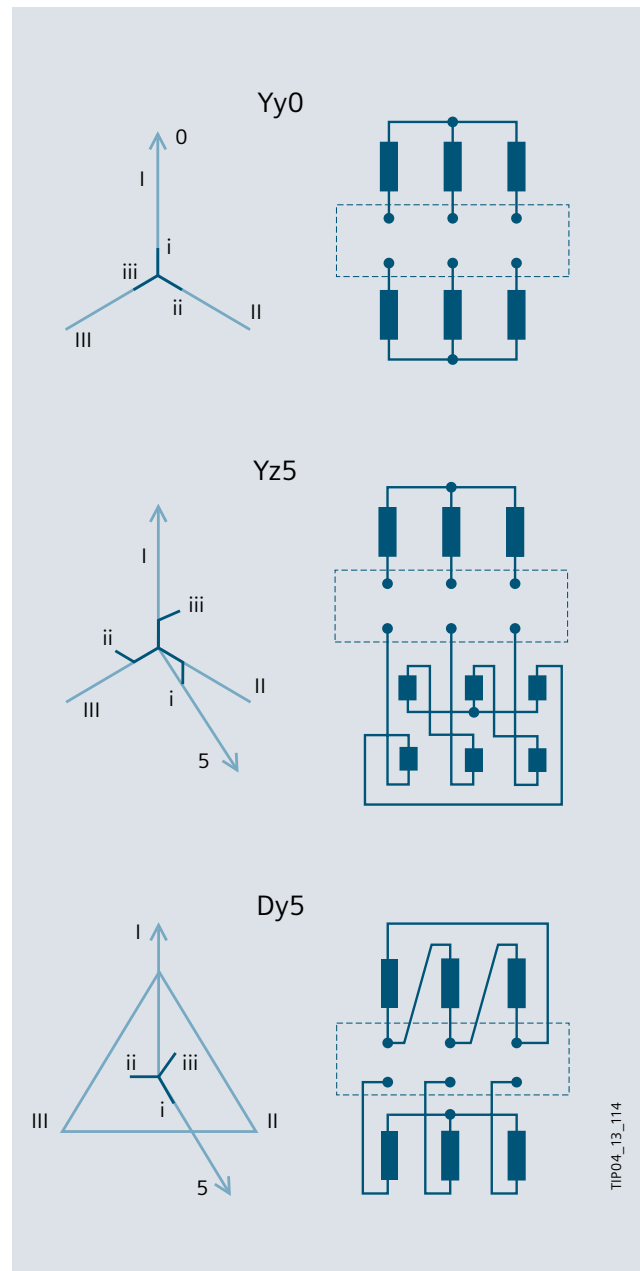

Fig. 9/2: Typical vector groups for three-phase transformers

TIP04\_13\_114



## 9.2 Losses and Profitability Estimates

The sharply risen prices for energy are increasingly forcing purchasers of electrical machines to carefully consider the system-inherent losses of these machines. This is of special importance for distribution transformers that run continuously and work under load. However, in most cases the higher cost of a loss-optimised transformer can be compensated in less than three years by energy savings.

### No-load losses ( $P_0$ )

No-load losses are the consumed active power if rated voltage is applied at rated frequency to the terminals of a winding while the other winding remains unloaded. They consist of losses in the iron core and the dielectric as well as the losses caused by the no-load current in the windings. The losses in the dielectric and the windings are generally irrelevant.

The iron core losses – i.e. the substantial part of the no-load losses – are composed of hysteresis losses and eddy current losses. Hysteresis losses are caused by flapping of the micro crystals which are elementary magnets. They respond to each turn and alignment by some resistance. Generally, the energy involved in this cannot be recovered, it is present in the form of heat loss.

The eddy currents present in the iron core in addition to the hysteresis losses are caused by the fact that the temporally variable magnetic field induces voltages in the iron core. These voltages generate currents which flow on eddy paths. Ohmic resistance of the iron and the eddy currents produce eddy current losses due to the relation  $I^2R$ . Eddy current losses can be reduced by using particularly thin, insulated iron sheets.

### Short-circuit losses ( $P_k$ )

Short-circuit loss is the consumed active power at rated frequency if the rated current flows through the conductor terminal of one of the windings while the terminals of the other winding are shorted. Short-circuit losses consist of current heat losses in the ohmic resistors ( $I^2R$ ) and the additional losses caused by eddy currents in the windings and in constructive parts.

Tab. 9/1 shows a simplified calculation method for a fast estimation of loss costs for a transformer example. The following assumptions are made:

- The transformers work continuously
- The transformers work under partial load, with constant partial load
- Additional costs and inflation factors are not taken into account
- The demand charges refer to 100% full load

#### Capital cost $C_c$

Annual capital costs  $C_c$  factor in:

- Purchase price  $C_p$  in €
- Interest rate  $p$  in %
- Depreciation period  $n$  in years

First, the interest factor  $q$  is calculated:

$$q = p / 100 + 1$$

and from this the depreciation factor  $r$ :

$$r = p \cdot q^n / (q^n - 1)$$

Capital costs  $C_c$  in € per annum are then:

$$C_c = C_p \cdot r / 100$$

#### Cost of no-load loss $C_{P0}$

No-load losses cause annual costs  $C_{P0}$

which are determined by:

- No-load losses  $P_0$  in kW
- Electricity cost  $C_e$  in € / kWh
- Number of hours per annum (8,760 h)

$$C_{P0} = C_e \cdot 8,760 \text{ h} \cdot P_0$$

#### Cost of load loss $C_{Pk}$

Load losses cause annual costs  $C_{Pk}$ ,

which are determined by:

- Winding losses  $P_k$  in kW
- Electricity cost  $C_e$  in € / kWh
- Load factor  $\alpha$  = Annual average operating output / nominal output
- Number of hours per annum (8,760 h)

$$C_{Pk} = C_e \cdot 8,760 \text{ h} \cdot \alpha^2 \cdot P_k$$

#### Cost resulting from demand charges $C_D$

The demand charge  $C_d$  (in € / kW) is fixed by the power supplier based on the demand requirements.

The costs  $C_D$  are the product of demand charge and total power loss:

$$C_D = C_d \cdot (P_k + P_0)$$

Tab. 9/1: Cost calculation for transformer selection

Tab. 9/2 shows a fictitious example. The factors used are common in Germany. The effects of inflation on the assumed demand charge are not factored in.

The short-circuit losses are converted to a reference temperature. For oil-immersed transformers this is 75°C. For cast-resin transformers these are:

- A = 80°C
- E = 95°C
- B = 100°C
- F = 120°C
- H = 145°C

Where the winding temperatures in classes A, E, B, F, and H from IEC 60076-11 (VDE 0532-76-11) are always raised by 20 °C following the description in EN 50541-1 (VDE 0532-241). EN 50541-1 (VDE 0532-241) presents a conversion formula for adapting short-circuit losses from 75°C, for example, to the temperature *T*:

For copper conductors:

$$\text{Correction factor } K_{Cu}(T) = (235 + T) / (235 + 75)$$

(for example  $K_{Cu}(120) = 1.145$ )

For aluminium conductors:

$$\text{Correction factor } K_{Al}(T) = (225 + T) / (225 + 75)$$

(for example  $K_{Al}(120) = 1.15$ )

If loads deviate from the rated duty, the short-circuit losses  $P_k$  change in the relation (load current / rated current) squared.

### Beispiel: Verteilungstransformator

Abschreibungszeitraum.....	$n = 20$ Jahre	Abschreibungs- Zinssatz $p = 12\%$ p.a. $\rightarrow$ Abschreibungs- faktor $r = 13,39$
Zinssatz .....	$p = 12\%$ p.a.	
Strompreis .....	$C_e = 0,25$ €/kWh	
Leistungspreis .....	$C_d = 350$ €/(kW × Jahr)	
entsprechender jährlicher Lastfaktor	$a = 0,8$	

#### A. Niederpreis- transformator

$P_0 = 19$ kW	Leerlaufverluste
$P_k = 167$ kW	Lastverluste
$C_p = € 521.000$	Kaufpreis

$$C_c = \frac{521.000 \times 13,39}{100} = € 69.762/\text{Jahr}$$

$$C_{p0} = 0,2 \times 8.760 \times 19 = € 33.288/\text{Jahr}$$

$$C_{pk} = 0,2 \times 8.760 \times 0,64 \times 167 = € 187.254/\text{Jahr}$$

$$C_D = 350 \times (19 + 167) = € 65.100/\text{Jahr}$$

Die Gesamterwerbs- und -betriebskosten dieses Transformators betragen daher:  
**€ 355.404/Jahr**

#### B. Verlustoptimierter Transformator

$P_0 = 16$ kW	Leerlaufverluste
$P_k = 124$ kW	Lastverluste
$C_p = € 585.000$	Kaufpreis

$$C_c = \frac{585.000 \times 13,39}{100} = € 78.332/\text{Jahr}$$

$$C_{p0} = 0,2 \times 8.760 \times 16 = € 28.032/\text{Jahr}$$

$$C_{pk} = 0,2 \times 8.760 \times 0,64 \times 124 = € 139.039/\text{Jahr}$$

$$C_D = 350 \times (16 + 124) = € 49.000/\text{Jahr}$$

Die Gesamterwerbs- und -betriebskosten dieses Transformators betragen daher:  
**€ 294.403/Jahr**

Durch die Energieeinsparung durch den optimierten Verteilungstransformator in Höhe von **€ 61.001 pro Jahr** amortisiert sich der höhere Anschaffungspreis in weniger als einem Jahr.

Tab. 9/2: Cost calculation for transformer selection

### 9.3 Construction of Oil-immersed Transformers

Essential components of oil-immersed transformers are:

- Iron core made of grain-oriented electrical sheet, insulated on both sides, core type
- Windings made of profiled copper wire, copper band, or aluminium band. The insulation has a high electric strength and is temperature-resistant. This ensures a long service life
- The rating for short-circuit strength is at least 2 s (IEC 60076-5; VDE 0532-76-5)
- Oil-filled tank, corrugated sheet wall type or as radiator tank
- Transformer truck with rollers (skids) can be supplied
- Cooling/insulation liquid: Mineral oil in accordance with IEC 60296 (VDE 0370-1); silicone oil or synthetic fluids available
- Standard varnishing for outdoor installation Varnishing types for special applications available (for example resistant against aggressive environmental impact)

#### Tank design

Completely enclosed standard distribution transformers have no oil conservator tanks and no gas buffer (Fig. 9/3). The TUMETIC transformers by Siemens are always completely filled with oil and in the event of oil expansion, the corrugated steel tank also expands (variable volume tank). Therefore, the maximum operating pressure is greatly limited.

The hermetically sealed system prevents the ingress of oxygen, nitrogen, or moisture into the cooling liquid, which improves the ageing characteristics of the oil to such an extent that the TUMETIC transformer requires no maintenance throughout its entire service life. Without an oil conservator tank, such as a TUNORMA transformer has, for example, the TUMETIC transformer is lower in height.

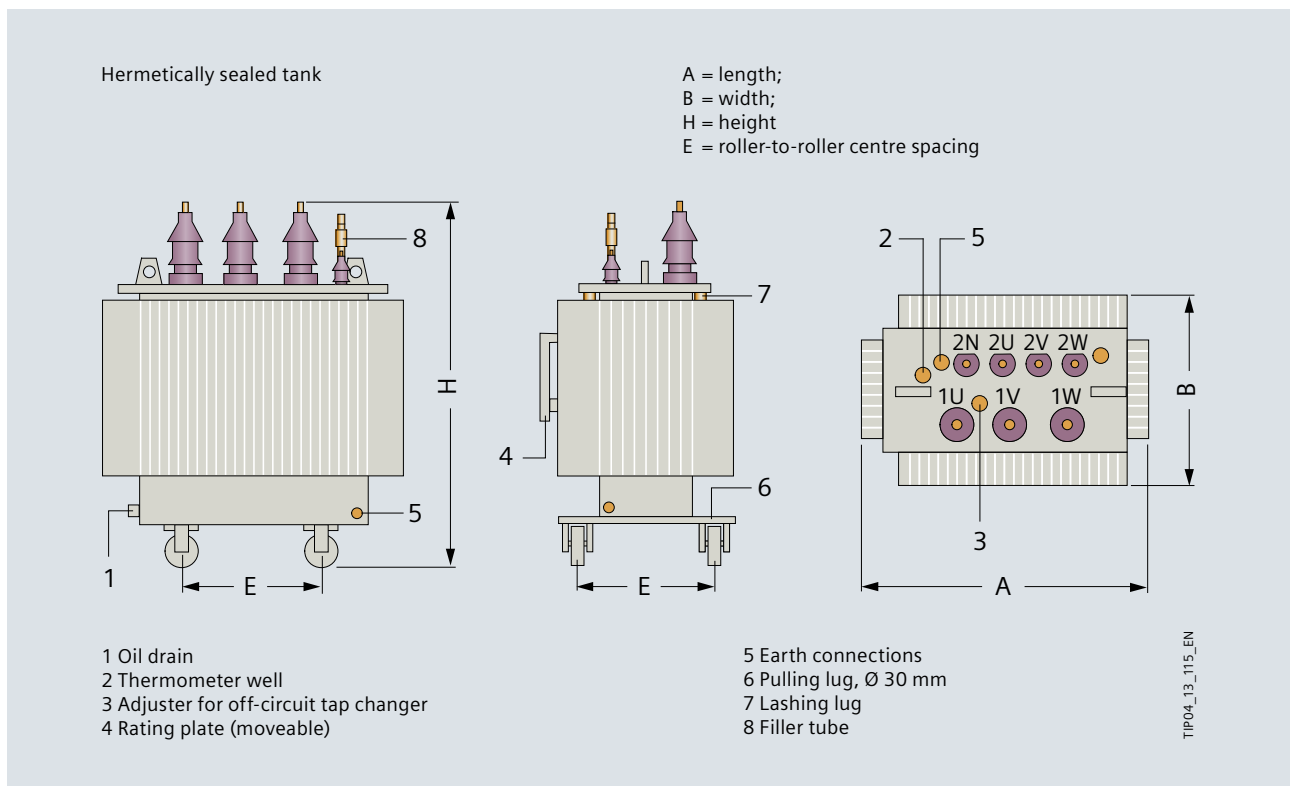

Fig. 9/3: Hermetically sealed oil-immersed distribution transformers

1

2

3

4

5

6

7

8

9

In a TUNORMA transformer (Fig. 9/4), the oil level in the tank and in the top-mounted bushing insulators is kept constant by means of an oil conservator tank, which is mounted at the highest point of the transformer. Changes in the oil level caused by varying thermal conditions only affect the oil conservator tank.

The design of the transformers depends on the requirements. For example, double-tank versions are available for special requirements in protected water catchment areas and versions with ultra-high interference reduction for use in EMC-sensitive areas.

### Cooling and insulating liquids

A distinction is also made between the cooling and the insulating liquid:

- Mineral oil that meets the requirements of the international regulations for insulating oil, IEC 60296 (VDE 0370-1), for transformers without any special requirements
- Silicone oil that is self-extinguishing when a fire occurs. Due to its high fire point of over 300°C, it is classified as a Category K liquid according to EN 61100 (VDE 0389-2)
- Diester oil, which does not pollute water and is biodegradable. Owing to a fire point of over 300°C, diester oil

also provides a high level of safety against fires and is also classified as K liquid according to EN 61100 (VDE 0389-2)

### Accessories and protection devices

For special applications and the enhancement of operational safety, oil-immersed transformers can be equipped with additional components such as:

- Protection of the cable terminals by cable boxes, flanged terminals, and/or angular plug connectors
- Buchholz relay to identify a pressure rise and detect gas (at the high- and/or low-voltage side)
- Indication of the real oil peak temperature by a pointer contact thermometer
- Warning in case of oil loss and gas accumulation in the TUMETIC transformer by a protection device
- Air dehumidifier for more reliable operation through a reduction of coolant humidity

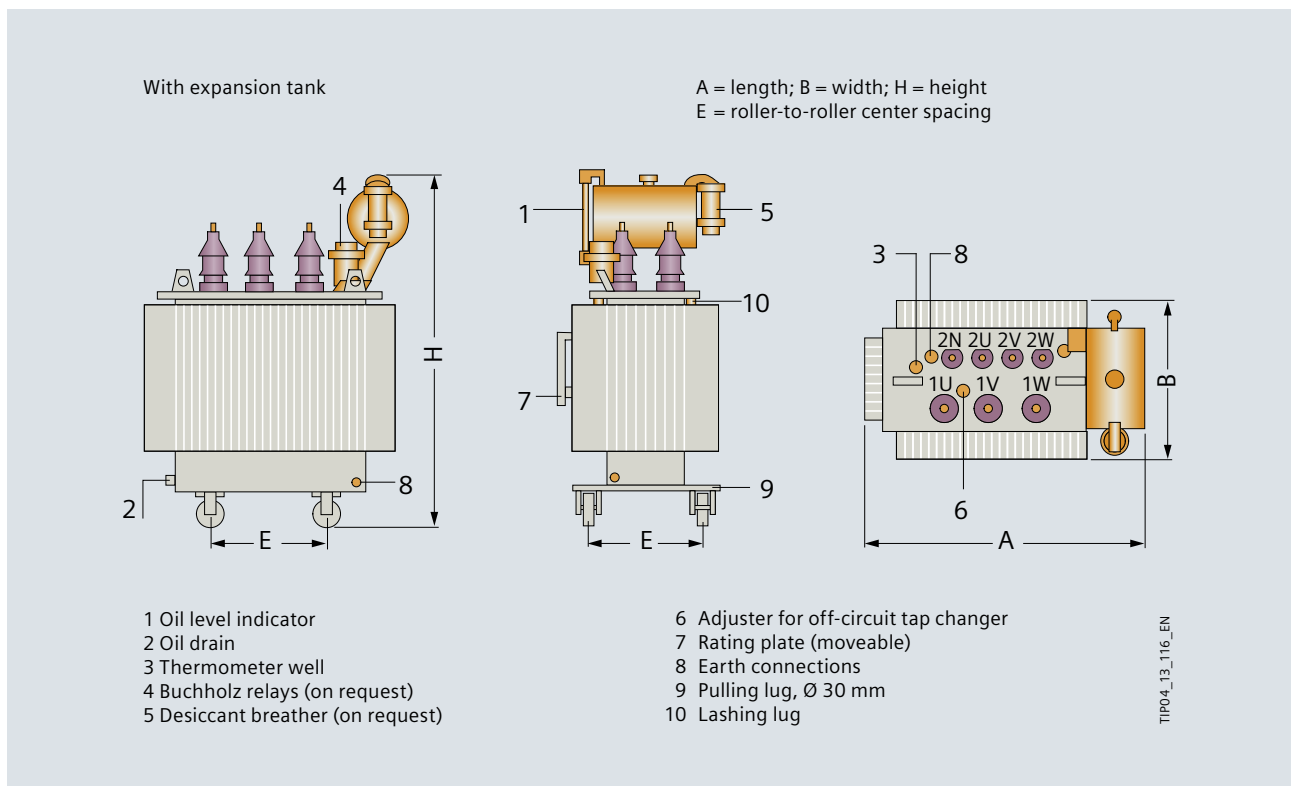

Fig. 9/4: Oil-immersed distribution transformer with conservator

## 9.4 GEAFOL Cast-resin Dry-type Transformers

Cast-resin transformers are the solution wherever distribution transformers in the immediate proximity to people must guarantee the greatest possible safety. The restrictions of liquid-filled transformers have been avoided with cast-resin transformers, but their proven characteristics such as operational safety and durability have been retained.

Requirements for the site of installation in accordance with IEC 61936-1 (VDE 0101-1) (fire protection see Tab. 9/3; for leakage no special measures are required, because there is no insulating and/or cooling liquid used) suggest the use of cast-resin dry-type transformers (for example GEAFOL). Compared to transformers using mineral oil, silicone oil or diester oil, these transformers place the lowest demands on the site of installation while fulfilling higher requirements in terms of personal safety and low fire load.

Type of transformer	Installation	Liquid volume V	Clearance <sup>2)</sup>		
			G1: to other transformers or building surface of non-combustible material	G2: to building surface of combustible material	
Oil insulated transformers (O) <sup>1)</sup>	Outdoor	1,000 l < V < 2,000 l	3 m	7.5 m	
		2,000 l ≤ V < 20,000 l	5 m	10 m	
		20,000 l ≤ V < 45,000 l	10 m	20 m	
		V ≥ 45,000 l	15 m	30 m	
		<b>Liquid volume V</b>	<b>Safety measures</b>		
	Indoor	V ≤ 1,000 l	EI 60 resp. REI 60 <sup>3)</sup>		
V > 1,000 l		EI 90 resp. REI 90 <sup>3)</sup> or EI 60 resp. REI 60 <sup>3)</sup> plus automatic fire-extinguishing appliance			
Fire resistant liquid insulated transformers (K) <sup>1)</sup>		<b>Liquid volume V</b>	<b>Clearance <sup>2)</sup></b>		
	Outdoor, without enhanced protection <sup>4)</sup>	1,000 l < V < 3,800 l	G1	G2	
		V ≥ 3,800 l	1.5 m	7.5 m	
			4.5 m	15 m	
			<b>Clearance G1 <sup>2)</sup> to building surface or adjacent transformers</b>		
	Outdoor, with enhanced protection <sup>4)</sup>	all	horizontal 0.9 m, vertical 1.5 m		
		<b>Operating data</b>	<b>Safety measures</b>		
Indoor, without enhanced protection <sup>4)</sup>		EI 60 resp. REI 60 <sup>3)</sup> or automatic fire-extinguishing appliance			
Indoor, with enhanced protection <sup>4)</sup>	for nom. power ≤ 10 MVA, max. voltage U <sub>m</sub> ≤ 38 kV	EI 60 resp. REI 60 <sup>3)</sup> or distances horizontal 1.5 m and vertical 3.0 m			
Dry-type transformers (A) <sup>1)</sup>		<b>Fire behaviour class <sup>5)</sup></b>	<b>Clearance G1 <sup>2)</sup> to building surface or adjacent transformers</b>		
	Outdoor	F0	horizontal 1.5 m, vertical 3.0 m		
		F1	No additional fire protection measures required		
		<b>Fire behaviour class <sup>5)</sup></b>	<b>Safety measures</b>		
	Indoor	F0	EI 60 resp. REI 60 <sup>3)</sup> or distance horizontal 0.9 m and vertical 1.5 m		
F1		Non combustible walls			
Note: Sufficient space should be allowed for periodic cleaning of resin-encapsulated transformer windings, in order to prevent possible electrical faults and fire hazard caused by deposited atmospheric pollution.					

<sup>1)</sup> Cooling medium identification (K, O) according to IEC 60076-2 (VDE 0532-76-2) resp. (A) according to IEC 60076-11 (VDE 053-76-11)

<sup>2)</sup> To visualise G1 and G2 see IEC 61936-1 (VDE 0101-1)

<sup>3)</sup> REI represents the bearing system (wall) whereas EI represents the non-load bearing system (wall) where R is the load bearing capacity, E is the fire integrity, I is the thermal insulation and 60/90 refers to fire resistance time (EN 13501-2) in minutes

<sup>4)</sup> Enhanced protection means: • tank rupture strength, • tank pressure relief, • low-current fault protection, • high-current fault protection

<sup>5)</sup> Fire behaviour class according to IEC 60076-11 (VDE 0532-76-11)

Tab. 9/3: Fire protection measures for transformers in accordance with IEC 61936-1 (VDE 0101-1)

Cast-resin transformers should at least meet the requirements C2 (Climate Category), E1 or E2 (Environment Category), and F1 (Fire Safety Category) as defined in IEC 60076-11 (VDE 0532-76-11) (see Tab. 9/4).

GEAFOL transformers are used wherever oil-immersed transformers must not be used: in buildings, in tunnels, on ships, on offshore cranes and oil platforms, in wind power stations, in groundwater protection areas, in the food processing industry, etc. The transformers are often combined with the low-voltage switchgear into load-centre substations. The GEAFOL transformers can be installed as power converter transformers for variable-speed drives together with the inverters at the drive location. This reduces the required building measures, cabling and installation costs as well as transmission losses.

GEAFOL transformers are designed to fully withstand voltage surges. They have similar noise levels as oil-immersed transformers. Considering the indirect cost savings mentioned above, they are also competitive in terms of price. Thanks to their design, GEAFOL transformers are largely free from maintenance during their entire service life.

Environment category limited	
Category E0	No condensation, pollution can be neglected
Category E1	Occasional condensation, limited pollution possible
Category E2	Frequent condensation or pollution, also both at the same time
Climate category	
Category C1	Indoor installation not under -5°C
Category C2	Outdoor installation down to -25°C
Fire safety category	
Category F0	There are no measures to limit the danger of fire
Category F1	The danger of fire is limited by the properties of the transformer

Tab. 9/4: Environment, climate, and fire safety categories in accordance with IEC 60076-11 (VDE 0532-76-11)

## 9.5 Power Converter Transformer

The operation of variable-speed three-phase motors using current converter connections requires the use of specially customized GEAFOLE transformers. The power converter transformer is the link between network and drive system, and shall ensure an adaptation to the network configuration on the one hand and decoupling from system perturbations of the converter connections on the other (Fig. 9/5). Particular attention must be given to the impact of harmonics produced by the converter, the surge operation and a possible DC current pre-magnetisation, and unbalanced load in the event of a fault. The 6-pulse or 12-pulse bridge connections for rectifying generate harmonics in the range of the 5th, 7th, 11th and 13th harmonic.

Common GEAFOLE transformers are designed for purely sine-shaped loads and would have to be oversized for use in combination with power converters. Whereas the GEAFOLE power converter transformer takes account of the increased electrical stress by a reinforced phase insulation compared to standard transformer versions. The following is achieved in this way:

- Higher electric strength of the insulation system
- Lower additional losses in the winding and core
- Higher impulse-load capacity

If consumers are connected which generate harmonics of a load current  $THD_i > 5\%$  – referred to the rated current – IEC 60076-1 (VDE 0532-76-1) recommends the use of a power converter transformer instead of a standard transformer.

The use of 12-pulse rectifiers with diodes and thyristors allows the low-frequency harmonic load (especially the 5th and 7th harmonic) to be reduced. Besides the use of two separate transformers for a 6-pulse rectifier bridge each, special three-windings transformers can be sized as power converter transformers. To attain the desired phase shift of  $30^\circ$  in the commutation between the two 6-pulse rectifiers, a star connection and a delta connection is connected to a 6-pulse bridge each at the low-voltage side.

If two transformers are used, they can be built up on top of each other as stacked power converter transformers. In that case, the  $30^\circ$  phase shift can either take place at the high- or the low-voltage side.

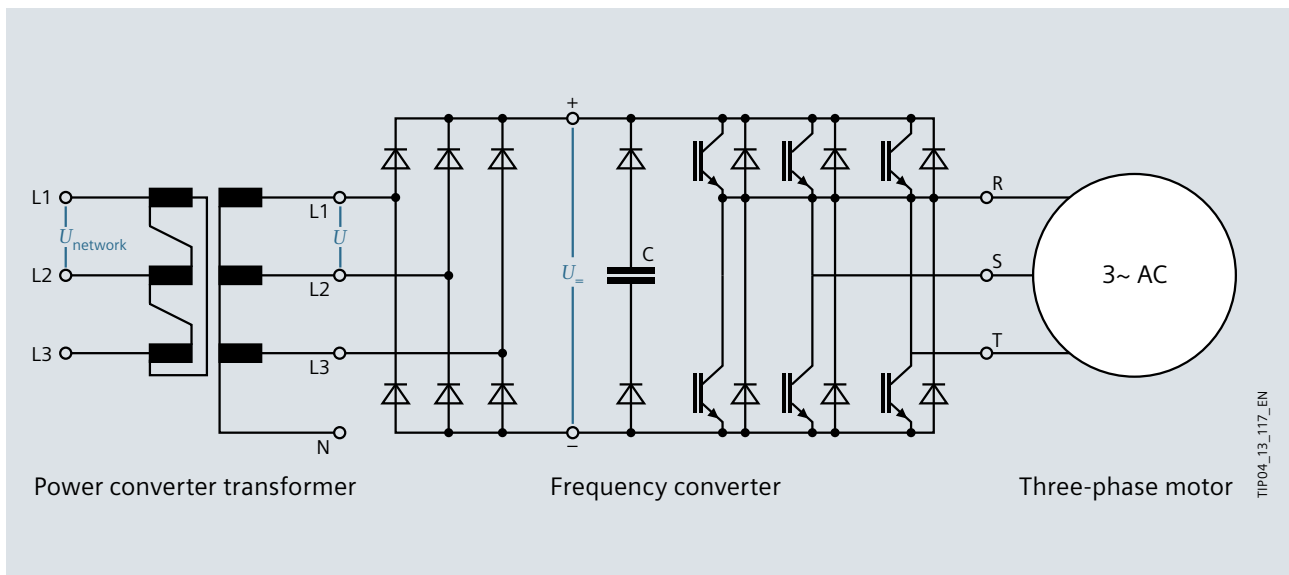

Fig. 9/5: Block diagram for a three-phase drive with power converter transformer and 6-pulse bridge connection

- 1
- 2
- 3
- 4
- 5
- 6
- 7
- 8
- 9
- 10
- 11
- 12
- 13
- 14
- 15
- 16
- 17

## 9.6 FITformer® REG – Regulated Distribution Transformer

Distributed power generation from regenerative energy sources is more than a trend of the time and results in the fact that the load flow in the power supply system is becoming increasingly complex in the future. The more profitable wind power stations and photovoltaic systems are becoming, the more attractive they will be in rural areas in particular – and the greater is the challenge for the grid operators to keep the voltage constant. The solution is the transformation of the grid infrastructure into a system which is efficient, powerful, and above all, adaptive. In its planning, customers and suppliers, as well as "prosumers" (who are electricity customers and

"producers" at the same time), play an important part, because their load purchases, their electricity feed-in, and their storage capacities vary greatly sometimes.

The regulated FITformer® REG distribution transformer (Fig. 9/6) is capable of changing its transformation ratio under load. Thus it ensures distributed feed-in of small power stations and helps the power supplier keep within the permissible voltage range and meet the requirements of EN 50160. To this end, the transformer provides three low-voltage taps in the hermetically sealed corrugated steel tank which are connected to the regulator positioned directly at the transformer.



Fig. 9/6: FITformer® REG



The connection basically consists of vacuum and air contactors, resistors, and a control unit. Its principle is that closing a contactor activates a bypass. Then the current flows through the bypass ("N") to ensure flawless switch-over of the mechanical vacuum contactors (Fig. 9/7), switch-over from "2" to "1". This prevents the occurrence of undesired voltage peaks or voltage dips during switch-over even under nominal load. When the target position has been reached, the contactor for the bypass is opened and thus deactivated. The control is event-driven and rules out internal faulty responses such as incorrect closing of a vacuum contactor.

Optionally, transformers of the FITformer® REG type can be equipped with additional current measuring instruments. They allow for a more precise evaluation of the grid condition with regard to the feed-in power of power stations and the load drawn in the low-voltage grid. An extension by these parameters increases the accuracy and reliability of transformer regulation. Additionally, the FITformer® REG model can be equipped with a communication processor for remote monitoring and control. To this end, the IEC 60870-5-101, IEC 60870-5-104, Modbus RTU and Modbus TCP/IP protocols are available for selection. This extension allows the regulated distribution transformer to be integrated into a smart grid. This enables taking distributed measurements in the low-voltage grid.

In the field of measurement techniques, Siemens provides the option of creating a superordinate control unit, relying on the SICAM product portfolio. This control unit is capable of fixing set values on the basis of measured process values both for the regulated distribution transformer and for distributed power generators. For this purpose, smart meters are directly integrated using the CX1 protocol. The existing distribution grid structure can here be optimally utilised for communication purposes by means of distribution line carriers. Alternatively, the FITformer® REG can also be controlled by external signals.

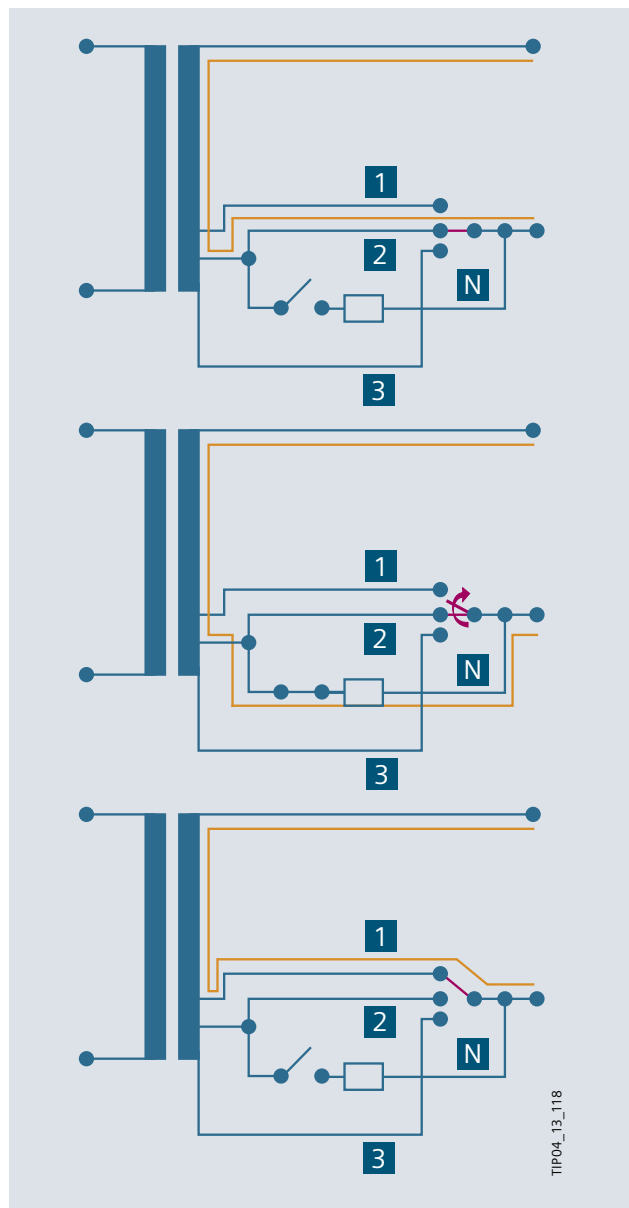

Fig. 9/7: Principle of switching under load for FITformer® REG

## 9.7 Transformer Operation

### Overtemperatures

Transformers are designed in such a manner that overtemperatures as permitted by regulations are not exceeded during rated operation. The overtemperature in the winding, and in liquid-filled transformers also the cooling and insulating liquid, is the difference between the part under consideration and the temperature of the ambient air. For ambient air, regulations specify maximum temperatures as well as mean day and annual temperatures.

The mean overtemperature applies to the winding, which is determined by the temperature dependence of its ohmic resistance. The maximum overtemperature of the cooling and insulating liquid results from temperature measurements in the thermometer pocket. For Siemens transformers, it is very often below the permissible overtemperature of the insulating liquid.

### Overload capability

In accordance with IEC 60076-1 (VDE 0532-76-1), transformer overloading is permitted if the specified values for the coolant temperature are undershot. The calculation for oil-immersed transformers is described in IEC 60076-7 (VDE 0532-76-7), respectively IEC 60076-12 (VDE 0532-76-12) for GEAFOL transformers.

A corresponding performance increase can be established for Siemens transformers according to a rule of thumb. It is:

- 1 % per 1 K<sup>1)</sup> undershooting the coolant temperature for oil-immersed transformers
- 0.6% per 1 K for GEAFOL transformers

Overloading the transformer without exceeding the permitted winding temperature is temporarily possible even if the previous continuous load was below the rated power, and provided that the permitted overtemperatures have not yet been reached despite overload.

Another transformer overloading option (performance-dependent up to about 50%) is fan blowing, this means a forced flow of the external coolant. However, it must be

<sup>1)</sup> 1 K=1 Kelvin is the SI unit for the thermodynamic temperature. It is defined as the 273.16th part of the thermodynamic temperature of 0.01 °C of the triple point of water. 0 K is the absolute point zero of the temperature, it corresponds to -273.15 °C)

kept in mind here that the short-circuit losses can also more than double compared to the short-circuit losses at nominal load. Therefore, additional ventilation is a proven means for covering peak loads as well as providing a reserve in case of a transformer failure when transformers are operated in parallel.

Notes for planning the low-voltage main distribution system (LVMD) and transformers under overload:

- Both the transformer feed-in circuit-breaker and the connection between transformer and LVMD must be sized for the increased nominal current! The short-circuit currents do not rise (for short-circuit behaviour please refer to the Appendix 17.1)
- The busbars of the low-voltage switchgear must be dimensioned for overload conditions
- Transformer losses increase in square under overload conditions (for example, 150% load results in approximately 225% transformer losses). Increased losses must be considered in the calculation of the discharge air volume for the transformer room!

### Parallel operation

Parallel operation prevails if transformers are connected to identical power supply systems both at their input and output side. As a rule, transformers characterized by vector groups with identical code numbers are suitable for parallel operation. Conductor terminals of the same name (1U-1U, 2U-2U, 1V-1V, 2V-2V, 1W-1W, 2W-2W) must then be connected to each other. But it is also possible to operate transformers in parallel with certain vector groups that have different code numbers provided that the conductor terminals are swapped accordingly. This is shown in Fig. 9/8 for transformers with vector groups in the common code numbers 5 and 11.

In case of an identical transformation ratio, the total load is distributed to the transformers connected in parallel proportional to the transformer outputs and inversely proportional to the short-circuit voltages. In case of identical input voltages and different output voltages of two transformers connected in parallel, a compensating current flows through both transformers which is approximated as follows:

$$I_{\text{comp. tr. 1}} = \frac{|\Delta_u|}{u_{\text{kr1}} + u_{\text{kr2}} \cdot \frac{S_{r1}}{S_{r2}}} \cdot 100$$

- $I_{\text{comp. tr. 1}}$  Compensating current of rated current for transformer 1 in percent
- $|\Delta_u|$  Absolute value of the input voltage difference of transformer 1 idling in percent
- $u_{\text{kr1}}, u_{\text{kr2}}$  Rated short-circuit voltages respectively short-circuit voltages at certain taps and/or deviations of the rated induction of transformers 1 and 2
- $S_{r1}/S_{r2}$  Ratio of rated outputs

The compensating current is independent of the load and its distribution. It also flows under no load. Under load, load current and compensating current are added as vectors. With an inductive power factor of the load current in the transformer with the higher secondary voltage, this always results in an increase of the total current, while the total current in the transformer with the lower secondary voltage decreases.

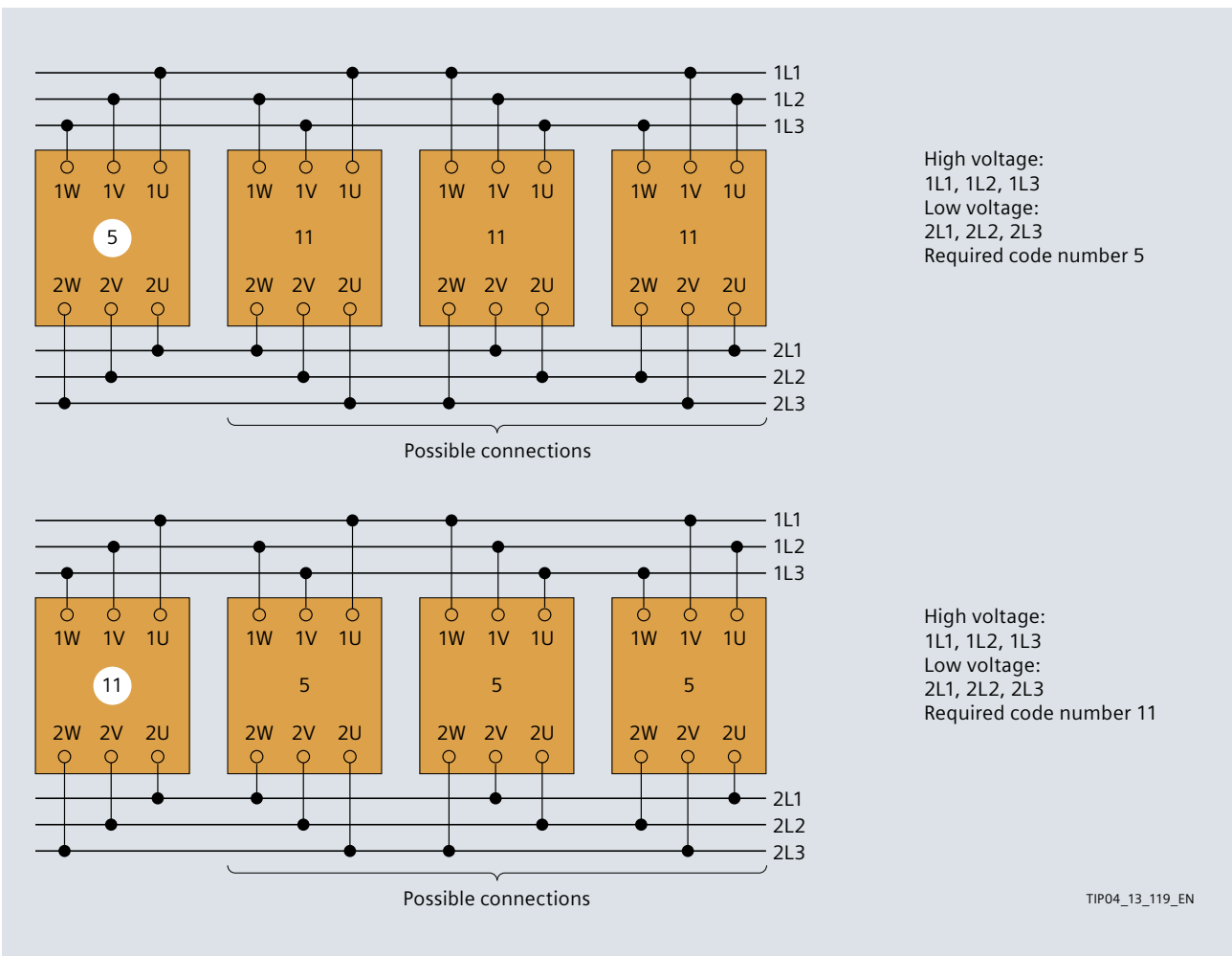

Fig. 9/8: Possible connections for transformers operated in parallel with vector groups of code numbers 5 and 11

In Example 1 (Tab. 9/5), the smaller transformer unfortunately happens to carry the higher secondary voltage and must therefore carry the higher total current. This means for this example that with a compensating current of 25.6% only a load current of 74.4% is permitted in order not to exceed the rated current of the smaller transformer 1 (corresponding to 100%). Consequently, the whole set of transformers can only be operated at 74.4% of its cumulated power of  $630 + 1,000 = 1,630$  kVA, which is about 1,213 kVA.

With a power factor for the load below 0.9, this estimate suggests a sufficiently precise guide value. With a power factor greater than 0.9, the permissible cumulated power rises due to the then growing vectorial difference value.

An adjustment of the regulator at a transformer may in certain circumstances improve the loading options. If it was possible to set a higher tapping at the high-voltage side in the 630-kVA transformer in our example (for instance 5% more windings), this would result in a reduction at the low voltage side by a factor of  $1/1.05$  for the smaller transformer 2 due to the induction decrease, when connected to the same high voltage, meaning 381 V instead of 400 V. Thus, the larger transformer with the higher voltage (390 V) would be leading.

If the low voltage of 381 V gained by this measure was too low, a lower tapping could be set at the high-voltage side in the 1,000-kVA transformer instead, if possible, and as demonstrated in Example 2 in Tab. 9/5 (for instance 5% fewer windings). As a result of the induction increase (check if permitted! More noise, core heating, no-load current) this would produce a higher low voltage by a factor of  $1/0.95$ , approximately 411 V instead of 390 V, for the larger transformer 2. Since transformer 2 now has the higher secondary no-load voltage, it carries the cumulated current from load and compensating current and hence determines the permitted total load of the two parallel transformers.

When changing the voltage setting, it must be kept in mind that the short-circuit voltage also changes. In transformers, the indirect voltage setting involved in an induction change leads to a change in the short-circuit voltage which is approximately proportional to the percentage of windings connected into or disconnected from supply.

**Example 1: Transformers with different secondary no-load voltages**

	Output voltage at no load in V	Rated power in kVA	Rated short-circuit voltage in %
Transformer 1	400	630	6
Transformer 2	390	1,000	6

$$|\Delta_u| = \left| \frac{400 - 390}{400} \cdot 100 \right| = 2.5 \%$$

$$\frac{S_{r1}}{S_{r2}} = \frac{630}{1,000} = 0.63$$

$$I_{\text{comp.tr.1}} \approx \frac{2.5}{6 + 6 \cdot 0.63} \approx 25.6 \%$$

$$S_r = (S_{r1} + S_{r2}) \cdot (100\% - I_{\text{comp.tr.1}}) = 1,213 \text{ kVA}$$

**Example 2: Transformer 2 with a 5% lower transformation and correspondingly higher secondary no-load voltage**

	Output voltage at no load in V	Rated power in kVA	Rated short-circuit voltage in %
Transformer 1	400	630	6
Transformer 2	411	1,000	5.7 ( $\approx 95\%$ of 6)

$$|\Delta_u| = \left| \frac{400 - 411}{400} \cdot 100 \right| = 2.75 \%$$

$$\frac{S_{r1}}{S_{r2}} = \frac{630}{1,000} = 0.63$$

$$I_{\text{comp.tr.1}} \approx \frac{2.75}{6 + 5.7 \cdot 0.63} \approx 28.7 \%$$

$$I_{\text{comp.tr.2}} \approx I_{\text{comp.tr.1}} \cdot \frac{S_{r1}}{S_{r2}} \approx 18.1 \%$$

$$S_r = (S_{r1} + S_{r2}) \cdot (100\% - I_{\text{comp.tr.2}}) = 1,335 \text{ kVA}$$

Tab. 9/5: Exemplary calculations for the cumulated power of transformers operated in parallel with varying outputs and voltages

Example 2 (Tab. 9/5) calculates with a 5% lower tap setting of the 1,000-kVA transformer. Since transformer 2 now has the higher secondary no-load voltage, it carries the cumulated current from load and compensating current and hence determines the permitted total load of the two parallel transformers. Assuming a power factor of the load below 0.9, the whole set of transformers can now be operated at approximately 81.9% of the cumulated power (81.9% of 1,630 kVA is 1,335 kVA).

In case of equal transformer ratings, the partial loads are inversely proportional to the short-circuit voltages. The transformer with the lower short-circuit voltage is loaded more than the one with the higher short-circuit voltage.

In case of a transformer load varying over time for a group of several transformers connected in parallel considering a defined period of time, a minimum of total losses can be attained by connecting individual transformers into or disconnecting them from supply. Short-circuit losses are a square function of the load. This means, the sum of short-circuit losses plus no-load losses may in certain circumstances be lower when the load is split between several transformers than if fewer transformers are used. To avoid a cumbersome loss comparison of the transformers operated in parallel, the partial load where a connection of an additional, identical transformer (the k-th transformer) is economically efficient can be determined as follows using a partial load factor n:

$$n = \frac{\text{Partial load}}{\text{Rated power}}$$

$$S_{\text{Group}} = n \cdot S_r$$

$S_{\text{group}}$  Output of the group

$S_r$  Rating of an individual transformer

n Partial load factor

The partial load factor n for efficient connection of a further identical transformer into supply (the k-th transformer) can be determined according to the following formula:

$$n = \sqrt{\frac{k \cdot (k - 1) \cdot P_0}{P_k}}$$

k Number of transformers to be connected in parallel

This means, the ratio of no-load to short-circuit losses  $P_0/P_k$  plays an important part for the group output in the parallel connection of transformers.

## 9.8 Transformer Room

Essential spatial requirements are described in IEC 61936-1 (VDE 0101-1). The propagation of fires, the noise level, ventilation, water pollution, and protection against indirect contact must be taken into account. Furthermore, the standard refers to the relevant national, regional, and local provisions and regulations. In addition, product-specific characteristics as described in the IEC 60076 (VDE 0532-76) series of standards play a role for room planning.

### Conditions for installation and room layout

Extreme local conditions must be taken into account when planning the system:

- The paint finish and prevailing temperatures are relevant for use in tropical climates
- For use in altitudes of more than 1,000 m above sea level a special configuration with regard to heating and insulation level is required, see IEC 60076-11 (VDE 0532-76-11)
- With increased mechanical demands being made – use in a ship, excavator, earthquake region, etc. – additional constructive measures may be required, e.g. supporting the upper yoke

GEAFOL cast-resin transformers can be installed in the same room as medium- and low-voltage switchgear without any extra precautions (Fig. 9/9). This helps save considerable costs for transformer cells. In contrast to a room for oil-immersed transformers, this room can be provided at or below ground surface or at the top floor of buildings.

With regard to fire protection of facilities, national or local regulations must usually be observed. For example, in Germany the *EltBauVO* (Ordinance on the construction of electrical operating areas) governs that doors in fire resistance class F30-A separate the electrical operating room (in accordance with DIN 4102-2) and walls in fire resistance class F90-A. However, firewalls (24 cm wall thickness) as for oil-immersed transformers, are not required for GEAFOL transformers.

The *EltBauVO* also governs that the spatial separation towards other rooms must not be endangered as a result of a pressure surge due to an arc fault. In terms of ventilation, it must also be observed that electrical operating areas must be directly vented into open air or by using separate intake / discharge air pipes. Air pipes leading through other rooms must be designed in a fire-resistant manner and the openings into open air must have protection grilles. Oil-immersed transformers (using mineral oil or synthetic fluids with a fire point  $\leq 300^\circ\text{C}$ ) require at least one exit leading directly outdoors into open air, or through an ante-room (without any connection to other rooms, except for the switchgear room if applicable).

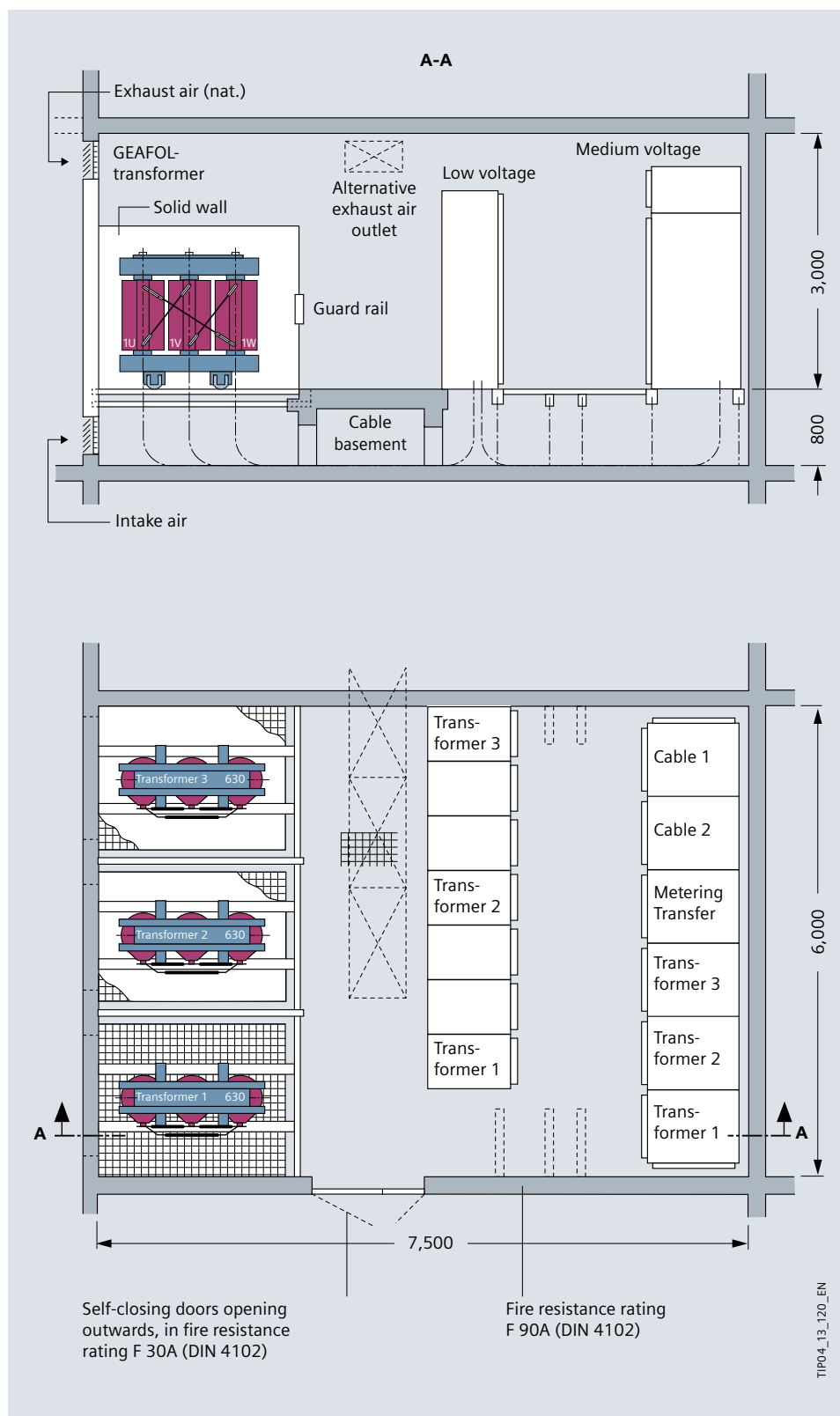

Fig. 9/9: Example of how to arrange GEAFOLE transformers and switchgear in an electrical operating area

[back to page 209](#)

The transformers are suitable for operation up to an altitude of 1,000 m above sea level. When installed in altitudes higher than 1,000 m, special versions are required. For every 100 metres that the permitted altitude of installation is exceeded, the nominal power must be reduced by approximately 0.4% for liquid-filled transformers, and by approximately 0.5% for cast-resin transformers.

### Transformer room ventilation and pressure estimate in case of an arc fault

Heat loss generated during any kind of transformer operation must be dissipated from the transformer room (Fig. 9/10). The possibility of natural ventilation should be checked first. If this is not sufficient, a mechanical ventilation system must be installed.

The heat loss results from the power loss of the transformer. The power loss of a transformer is:

$$P_v = P_0 + 1.1 \cdot P_{K120} \cdot (S_{AF}/S_{AN})^2 \text{ kW}$$

- $P_0$ : No-load losses (kW)
- $1.1 \cdot P_{K120}$ : Short-circuit losses at 120°C (according to the list or, if already available, the test certificate specifications), multiplied by a factor of 1.1 for the working temperature of the insulation categories HV/LV = F/F for GEAFOL transformers.
- $S_{AF}$ : Power (kVA) for forced ventilation AF (air forced)
- $S_{AN}$ : Apparent power (kVA) for natural ventilation AN (natural air flow)

The total heat loss in the room ( $Q_v$ ) is the sum of the heat losses of all transformers in the room:

$$Q_v = \sum P_v$$

*Note: Our TIP contact person can support the electrical designer with complex calculations of the heat dissipation for arbitrary parameters and when combining ventilation measures (refer to the Contact pages in this manual or the web page: [siemens.com/tip-cs/contact](http://siemens.com/tip-cs/contact)).*

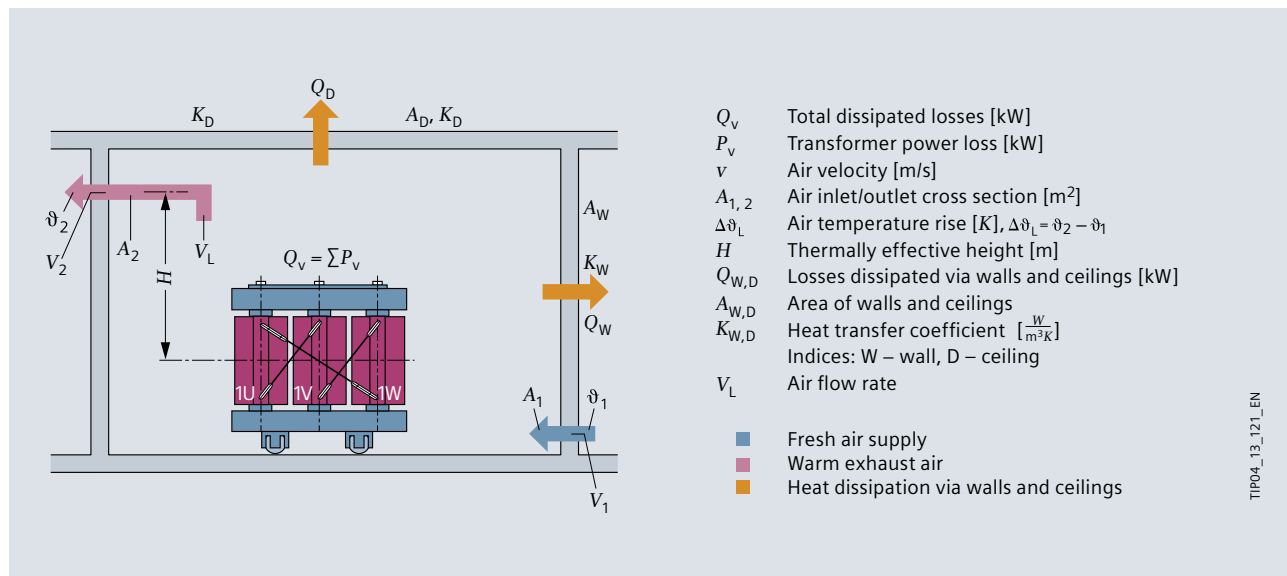

Fig. 9/10: Specifications for the ventilation calculation

### Calculation of the heat dissipation

The following methods are available for the dissipation of the entire power loss  $Q_V$  in the room:

- $Q_{V1}$  dissipation with the natural air flow
- $Q_{V2}$  dissipation via walls and ceilings
- $Q_{V3}$  dissipation with the forced air flow

$$Q_V = P_V = Q_{V1} + Q_{V2} + Q_{V3}$$

To illustrate the size of the variables for the different ventilation methods, linear dependencies can be derived by specifying realistic values. For a thermally effective height of 5 m, an air temperature rise of 15 °C between the inside and outside area, a uniform heat transfer coefficient of 3.4 W/m<sup>2</sup> for 20 cm thick concrete and an air flow rate of 10,000 m<sup>3</sup>/h for forced ventilation, which is led through an air duct with an inlet/outlet cross section that is approximately four times as large.

$Q_{V1} = \text{approx. } 13 \text{ kW/m}^2 \cdot A_{1,2} \text{ m}^2$   
 (Example:  $Q_{V1} = 8 \text{ kW}$  for a cross section of approx. 0.62 m<sup>2</sup>)

$Q_{V2} = \text{approx. } 0.122 \text{ kW/m}^2 \cdot A_D \text{ m}^2$   
 (Example:  $Q_{V2} = 8 \text{ kW}$  for a surface area of approx. 66 m<sup>2</sup>)

$Q_{V3} = \text{approx. } 44 \text{ kW/m}^2 \cdot A_{1,2} \text{ m}^2$   
 (Example:  $Q_{V3} = 8 \text{ kW}$  for a cross section of approx. 0.18 m<sup>2</sup>)

These simple examples show that the heat dissipation through walls and ceilings quickly reaches the limits of the room and that for large transformer outputs, a detailed configuration of the forced ventilation may be necessary (also refer to the Siemens publication "GEAFOL Cast-Resin Transformers"; Planning Guidelines, order no. E50001-G640-A109-V3-7600). Our Siemens TIP contact persons can support electrical designers in estimating ventilation conditions in a defined room size and help adjust ventilation measures accordingly (see [siemens.com/tip-cs/contact](http://siemens.com/tip-cs/contact)).

Further support that can be offered to electrical designers by our TIP contacts as a free of charge service for GEAFOL transformers is estimating the pressure rise under arc fault conditions. Besides a graphical evaluation of the pressure development (Fig. 9/11), the data on ventilation and pressure rise in the transformer room is output.

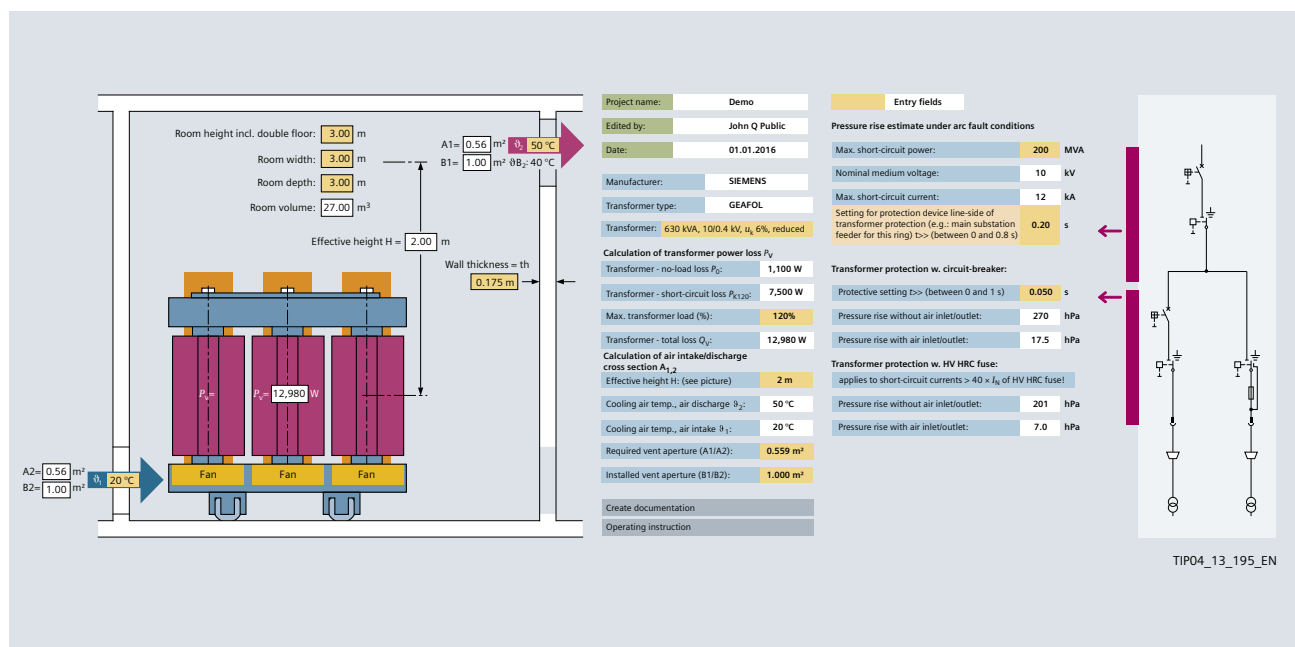
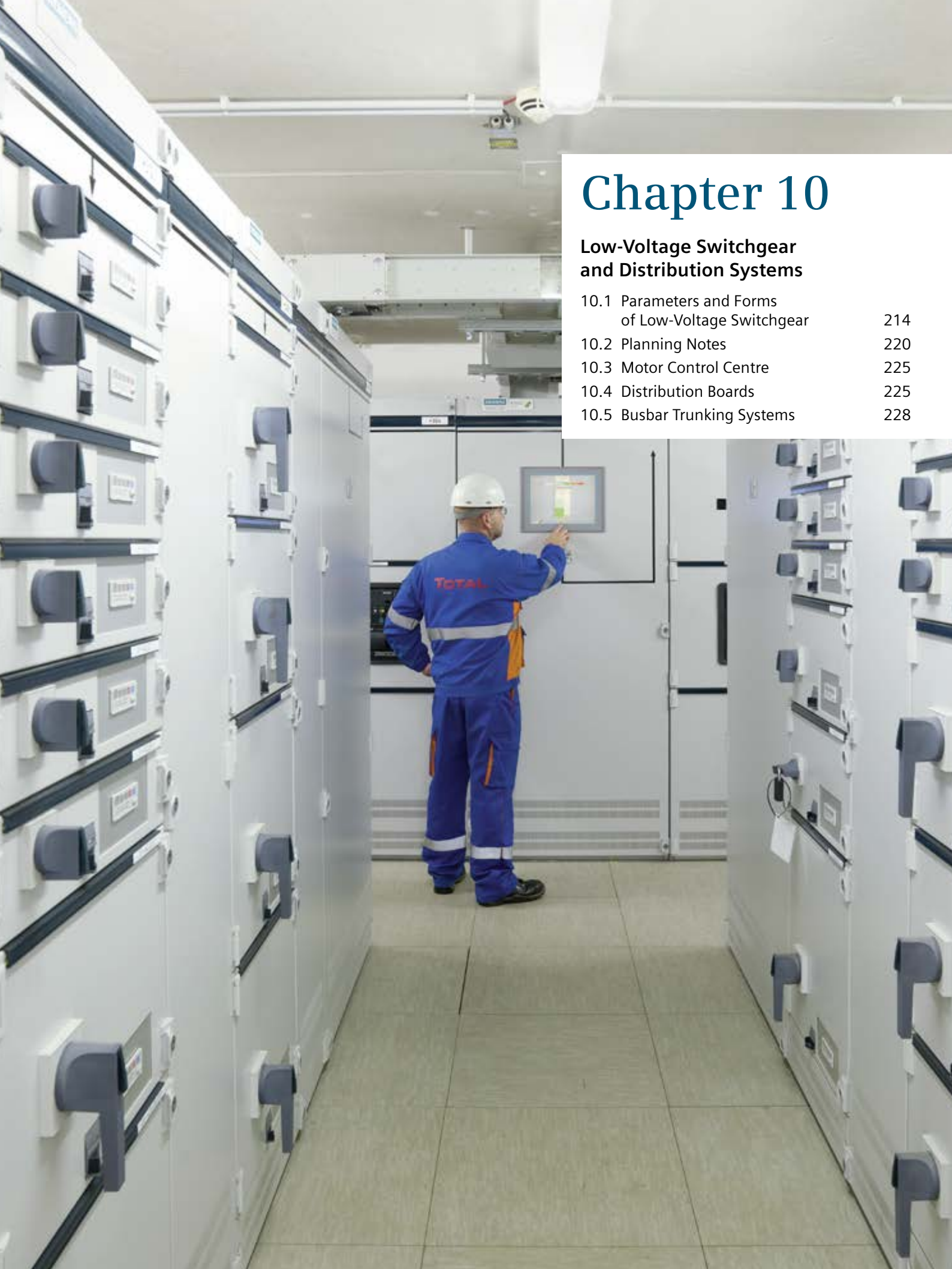

Fig. 9/11: Ventilation of transformer room and approximated pressure rise under arc fault conditions





# Chapter 10

## Low-Voltage Switchgear and Distribution Systems

10.1 Parameters and Forms of Low-Voltage Switchgear	214
10.2 Planning Notes	220
10.3 Motor Control Centre	225
10.4 Distribution Boards	225
10.5 Busbar Trunking Systems	228

# 10 Low-Voltage Switchgear and Distribution Systems

## 10.1 Parameters and Forms of Low-Voltage Switchgear

Low-voltage switchgear<sup>1)</sup> and distribution boards form the link between the equipment for the generation (generators), transmission (cables, overhead lines) and transformation (transformers) of electrical energy on the one hand and the consumers, e.g. motors, solenoid valves, devices for heating, lighting, air conditioning, and the information technology on the other hand. For alternating voltage, the rated voltage is 1,000 V max., for direct voltage it is 1,500 V max.

Like medium-voltage switchgear, low-voltage switchgear is also less often installed with individual cubicle design on site, but delivered as factory-assembled, design verified switchgear. For design verification, testing is to be accomplished successfully in compliance with IEC 61439-1 (VDE 0660-600-1) and IEC 61439-2 (VDE 0660-600-2).

Test verification under arc fault conditions in accordance with IEC/TR 61641 (VDE 0660-500, Addendum 2) ensures maximum safety of persons. Protection measures such as high-quality insulation of live parts (for example busbars), uniform and easy handling, integrated operator fault protection, and reliable switchgear dimensioning prevent arc faults and hence personal injuries. The main components of the switchgear are busbars, switching devices, secondary structures, protection equipment, measuring and counting instruments. The essential selection criteria according to which low-voltage switchgear and distribution boards are designed are the following:

### Rated currents

- Rated current  $I_r$  of the busbars
- Rated current  $I_r$  of the feed-in
- Rated current  $I_r$  of the branch circuits
- Rated short-time current  $I_{cw}$  of the busbars
- Rated peak short-circuit current  $I_{pk}$  of the busbars

### Degree of protection and type of installation

- Degree of protection in acc. with IEC 60529 (VDE 470-1)
- Protection against electric shock (safety class) in acc. with IEC 60364-4-41 (DIN VDE 0100-410)
- Enclosure material
- Type of installation (on the wall, stand-alone)
- Number of front operating cubicles

### Type of device installation

- Fixed installation
- Plug-in design
- Withdrawable-unit design
- Snap-on fixing on mounting rail

### Usage

- Main switchgear or main distribution board
- Sub-distribution board
- Line distribution board
- Motor, installation, industry distributor
- Light or power distributor
- Reactive power compensation unit
- Control unit

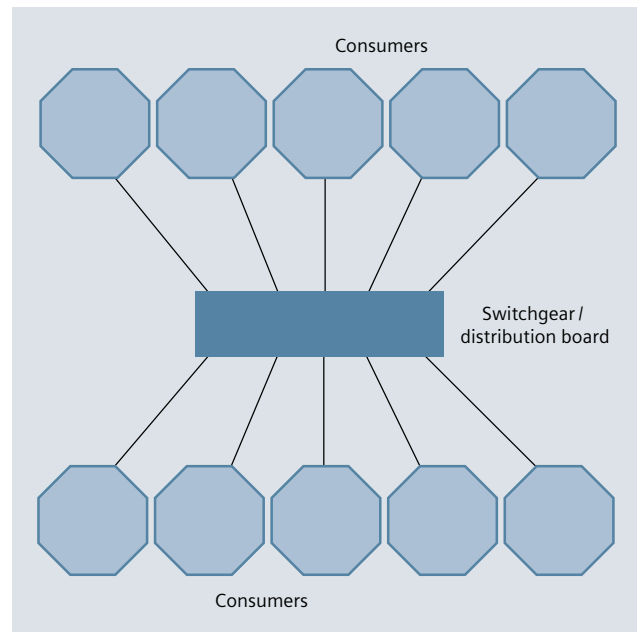

Fig. 10/1: Schematic diagram of a point-to-point distribution board

<sup>1</sup> In the associated standards, the term 'power switchgear and controlgear, PSC assembly' is used

Depending on the type of power distribution, a differentiation is made between point-to-point distribution boards and line distribution boards. In point-to-point distribution boards, the electric power is distributed radially from a spatially limited system (see Fig. 10/1). Whereas in line distribution boards – today mostly busbar trunking systems – the individual power tapplings take place via spatially separated equipment and the power is transmitted to these tap-off units by means of encapsulated busbars (see Fig. 10/2).

In point-to-point distribution boards, one transformer per busbar section supplies the main switchgear. The downstream motor distributors, control units, distributors for lighting, heating, air conditioning, workshops, etc. – that is, those fed by the main switchgear in turn – are referred to as sub-distribution boards. The combination of a main switchgear with feed-in transformer is referred to as transformer load-centre substation and provides – due to its compactness – a secure and economic option of distributed power supply in compliance with the factory-assembled stations described in IEC 62271-202 (VDE 0671-202).

When planning low-voltage switchgear, the prerequisite for efficient dimensioning is the knowledge of the local conditions, the switching duty, and the demands on availability. For power distribution systems in functional buildings, no large switching frequencies have to be considered and no major extensions are to be expected. Therefore, performance-optimised technology with high component

density can be used. In these cases, mainly fuse-protected equipment in fixed-mounted design is used.

In a power distribution system or motor control centre for a production plant, however, replaceability and reliability of supply are the most important criteria in order to keep downtimes as short as possible. A vital basis here is deploying withdrawable-unit systems both in circuit-breaker-protected and in fuse-protected design.

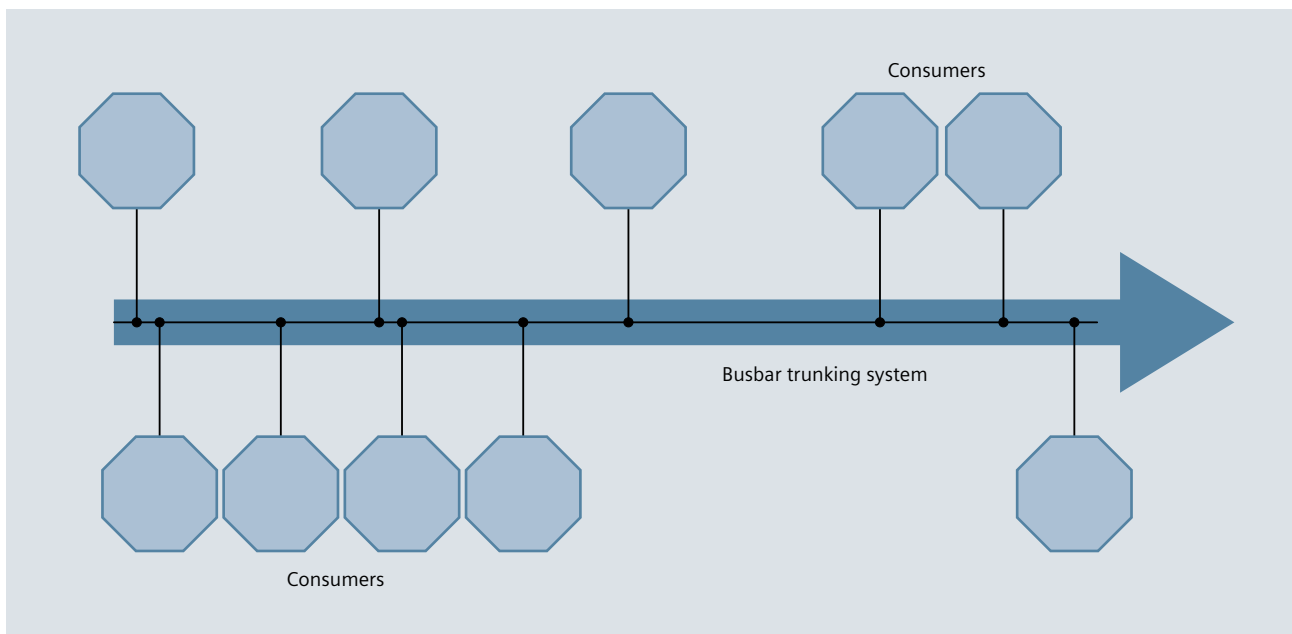

Fig. 10/2: Schematic diagram of a line distribution board

1

2

3

4

5

6

7

8

9

10

11

12

13

14

15

16

17

A multi-purpose low-voltage switchgear installation is characterized by numerous combination possibilities of different mounting designs within one cubicle and variable forms of internal separation. The forms described in IEC 61439-2 (VDE 0660-600-2) are listed in Tab. 10/1.

The mounting designs for switchgear equipment can be selected dependent on the usage:

- Circuit-breaker design
- Universal mounting design
- In-line switch-disconnector design
- Fixed-mounted design
- Reactive power compensation

(See Fig. 10/3 and Tab. 10/2 and Tab. 10/3)

Form	Block diagram	Explanations
1		No internal separation
2a		Separation between busbars and functional units
2b		Separations between terminals and busbars
3a		Separation between busbars and functional units
3b		+ Separation between functional units
4a		+ Separation between terminals and functional units
4b		Terminals in the same compartment as the connected functional unit
		Terminals not in the same compartment as the connected functional unit
<p>Legend:</p>		

Tab. 10/1: Forms of internal compartmentalisation of power switchgear assemblies

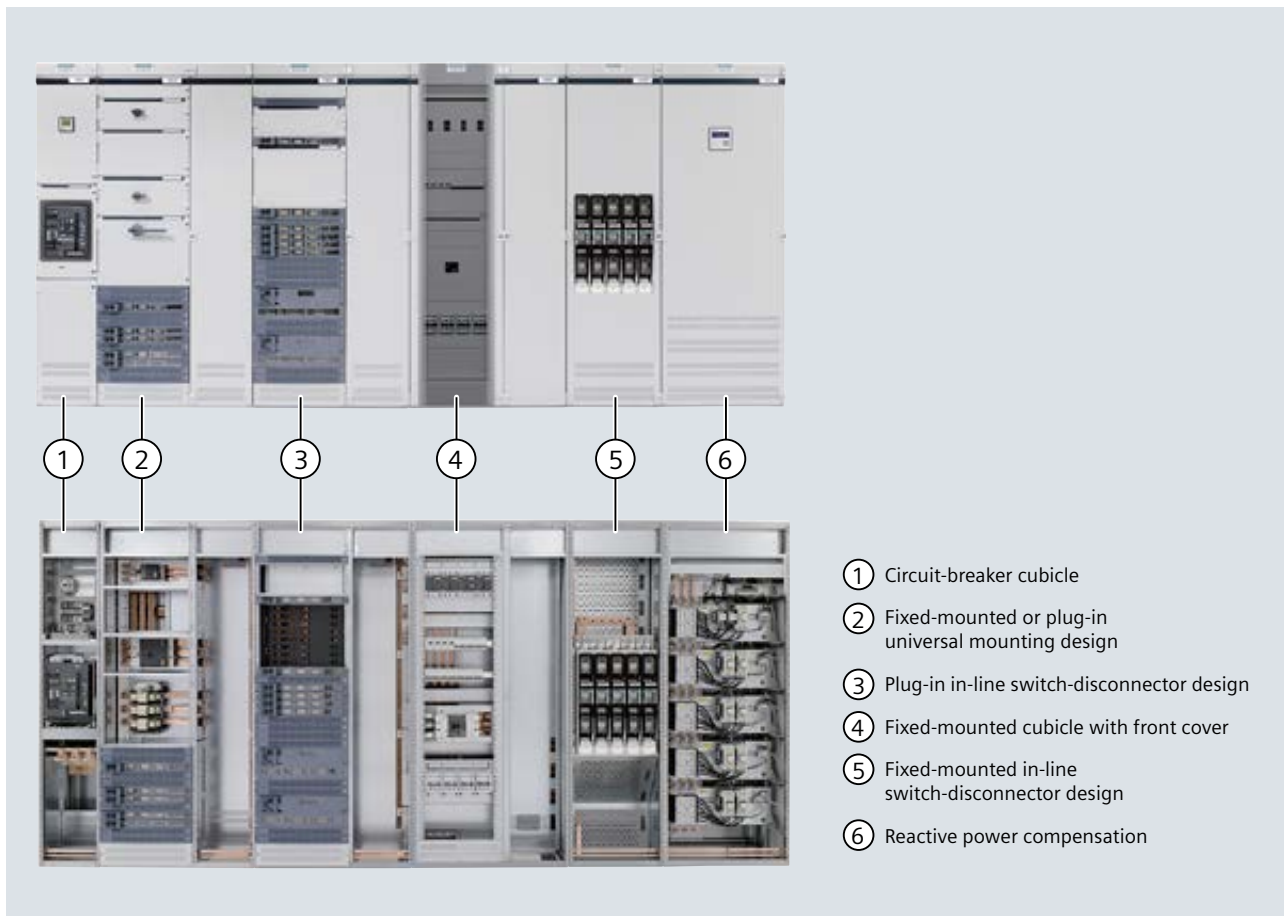

- ① Circuit-breaker cubicle
- ② Fixed-mounted or plug-in universal mounting design
- ③ Plug-in in-line switch-disconnector design
- ④ Fixed-mounted cubicle with front cover
- ⑤ Fixed-mounted in-line switch-disconnector design
- ⑥ Reactive power compensation

Fig. 10/3: Mounting designs for SIVACON S8 low-voltage switchgear

[back to page 216](#)

Cubicle type	Circuit-breaker design	Universal mounting design	3NJ6 in-line switch-disconnector design	Fixed-mounted design	3NJ4 in-line switch-disconnector design	Reactive power compensation
Mounting design	Fixed-mounted Withdrawable unit	Fixed-mounted Plug-in Withdrawable unit	Plug-in	Fixed-mounted with front covers	Fixed-mounted	Fixed-mounted
Function	Feed-in Outgoing feeder Coupling	Cable outlets Motor feeder (MCC)	Cable feeder	Cable feeder	Cable feeder	Central compensation of the reactive power
Current $I_n$	6,300 A max.	630 A max.	630 A max.	630 A max.	630 A max.	unchoked up to 600 kvar choked up to 500 kvar
Connection	Front and rear side	Front and rear side	Front side	Front side	Front side	Front side
Cubicle width in mm	400/600/800/ 1,000/1,400	600/1,000/1,200	1,000/1,200	1,000/1,200	600/800/1,000	800
Internal separation	Form 1, 2b, 3a, 4b, 4 type 7 (BS)	Form 3b, 4a, 4b, 4 type 7 (BS)	Form 3b, 4b	Form 1, 2b, 3b, 4a, 4b	Form 1, 2b	Form 1, 2b
Busbars	Rear/top	Rear/top	Rear/top	Rear/top	Rear	Rear/top/without

Tab. 10/2: Various mounting designs according to cubicle types

[back to page 216](#)

Busbar position at the top			
Installation	Busbar system		Cubicle design
Single front  Installation on the wall, stand-alone in the room, back-to-back	Busbar position	at the top	
	Rated current	3,270 A max.	
	Cable/busbar entry	from the bottom	
	Connection in the cubicle	Front	
Single front  Installation on the wall, stand-alone in the room, back-to-back	Busbar position	at the top	
	Rated current	3,270 A max.	
	Cable/busbar entry or terminal compartment	from the top on the back	
	Connection in the cubicle	Front or rear	
Single front  Installation on the wall, stand-alone in the room, back-to-back	Busbar position	at the top	
	Rated current	6,300 A max.	
	Cable/busbar entry	from the bottom	
	Connection in the cubicle	Front	
Single front  Installation on the wall, stand-alone in the room, back-to-back	Busbar position	at the top	
	Rated current	6,300 A max.	
	Cable/busbar entry or terminal compartment	from the top at the back	
	Connection in the cubicle	Front or rear	

Device/functional compartment
  Busbar compartment
  Cable/busbar connection compartment
  Cross-wiring compartment
  Operating cubicles

Tab. 10/3: Cubicle types and arrangement of the busbars on the cubicles

[back to page 216](#)

Busbar position at the rear			
Installation	Busbar system		Cubicle design
Single front Installation on the wall, stand-alone in the room, back-to-back	Busbar position	rear-top or -bottom, top, and bottom	
	Rated current	4,000 A max.	
	Cable /busbar entry	from the bottom, from the top	
	Connection in the cubicle	Front	
Single front Installation on the wall, stand-alone in the room, back-to-back	Busbar position	rear-top or -bottom	
	Rated current	7,010 A max.	
	Cable /busbar entry	from the bottom, from the top	
	Connection in the cubicle	Front	
Double front Stand-alone in the room	Busbar position	top- or bottom-centre, top, and bottom	
	Rated current	4,000 A max.	
	Cable /busbar entry	from the top, from the bottom	
	Connection in the cubicle	Front	
Double front Stand-alone in the room	Busbar position	top- or bottom-centre	
	Rated current	7,010 A max.	
	Cable /busbar entry	from the bottom, from the top	
	Connection in the cubicle	Front	

Device/functional compartment
  Busbar compartment
  Cable/busbar connection compartment
  Cross-wiring compartment
 ▶ Operating cubicles

Tab. 10/3: Cubicle types and arrangement of the busbars on the cubicles

[back to page 216](#)

## 10.2 Planning Notes

The following aspects should be kept in mind when planning a switchgear:

- Maximally permitted equipment of a cubicle (for example, number of in-line switch-disconnectors considering size and load; manufacturer specifications must be observed!).
- Minimum cubicle width, considering component density, conductor cross sections and number of cables (a wider terminal compartment may have to be selected or an additional cubicle may have to be configured)
- Device reduction factors must be observed according to manufacturer specifications! Mounting location, ambient temperature and nominal current play an important part (particular attention in case of currents greater than 2,000 A!).
- The dimensioning of compensation systems is very much governed by the location of use (office, production) and the power supply conditions (harmonic content, DSO specifications, audio frequency etc.). Up to about 30 % of the transformer output can be expected as a rough estimate (in industrial environments) in the absence of concrete criteria for planning. If switched-mode power supply units are increasingly used, for example in ICT equipment in office rooms, the power factor may even turn capacitive. In this context, it must be observed that these power supply units frequently cause system perturbations in the form of harmonics, which can be reduced by passive or active filters.
- The decision in favour of central or distributed implementation of compensation is governed by the network configuration (load center of reactive current sources). In case of distributed arrangement of the compensation systems, appropriate outgoing feeders (in-line switch-disconnectors, circuit-breakers etc.) shall be provided in the switchboard.

- Generator-supplied power systems must not be compensated if problems may arise in generator control as a result of compensation control (disconnecting the compensation system during switch-over to generator mode or static, generator-tuned compensation is possible)
- Choking of a compensation system depends on the power system requirements as well those of the client and the DSO.
- Generator-fed networks must not be compensated if a regulated compensation could lead to problems in the generator control (deactivate compensation upon switching to generator mode or use fixed compensation matched to the generator is possible)
- Choking of a compensation system depends on the requirements of the network, the customer, and also the DSO.

### Installation – clearances and corridor widths

When low-voltage switchboards are installed, the minimum clearances between switchboards and obstacle as specified by the manufacturer must be observed (Fig. 10/4). The minimum dimensions for operating and maintenance gangways according to IEC 60364-7-729 must be taken into account when planning the space required (Fig. 10/5). When using a lift truck for the insertion of circuit-breakers, the minimum gangway widths must be matched to the dimensions of the lift truck! Reduced gangway width within the range of open doors must be paid attention to (Fig. 10/6). With opposing switchboard fronts, constriction by open doors is only accounted for on one side. SIVACON S8 doors can be fitted so that they close in escape direction. The door stop can easily be changed later. Moreover, the standard requires a minimum door opening angle of 90°.

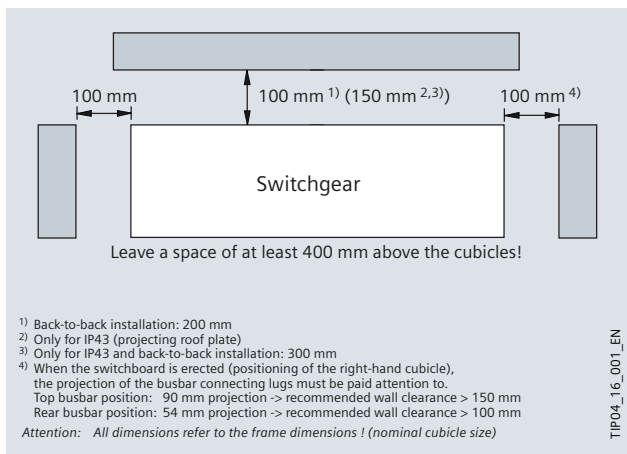

Fig. 10/4: Clearances to obstacles

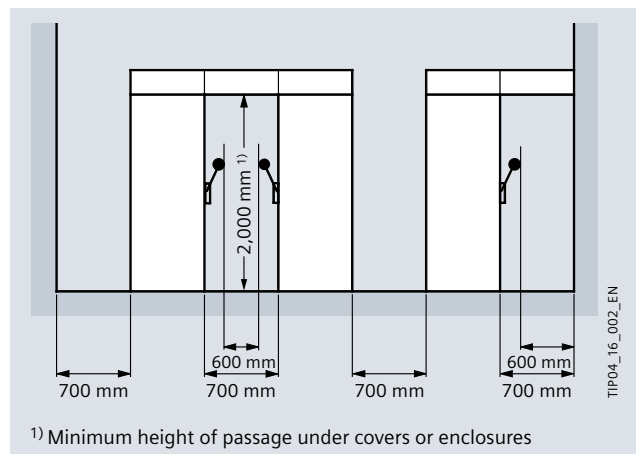

Fig. 10/5: Maintenance gangway widths and passage heights



### Altitude

The altitude of installation must not be above 2,000 m above sea level.

Switchgears and equipment which are to be used in higher altitudes require that the reduction of dielectric strength, the equipment switching capacity and the cooling effect of the ambient air be considered. Further information is available from your Siemens contact.

### Environmental conditions for switchgear

The climate and other external conditions (natural foreign substances, chemically active pollutants, small animals) may affect the switchboard to a varying extent. The influence depends on the air-conditioning equipment of the switchgear room.

According to IEC 61439-1 (VDE 0100-729), environmental conditions for low-voltage switchgears are classified as:

- Normal service conditions (IEC 61439-1, section 7.1)
- Special service conditions (IEC 61439-1, section 7.2)

SIVACON S8 switchgears are intended for use in the normal environmental conditions. If special service conditions prevail, special agreements between the switchgear manufacturer and the user must be reached. The user must inform the switchgear manufacturer about such extraordinary service conditions.

Special service conditions relate to the following, for example:

- Data about ambient temperature, relative humidity and/or altitude if this data deviates from the normal service conditions
- The occurrence of fast temperature and/or air pressure changes, so that extraordinary condensation must be expected inside the switchboard
- An atmosphere which may contain a substantial proportion of dust, smoke, corrosive or radioactive components, vapours or salt (e.g. H<sub>2</sub>S, NO<sub>x</sub>, SO<sub>2</sub>, chlorine)

In case of higher concentrations of pollutants (Class > 3C2) pollutant reducing measures are required, for example:

- Air-intake for service room from a less contaminated point
- Expose the service room to slight excess pressure (e.g. injecting clean air into the switchboard)
- Air conditioning of switchboard rooms (temperature reduction, relative humidity < 60%, if necessary, use pollutant filters)
- Reduction of temperature rise (oversizing of switching devices or components such as busbars and distribution bars).

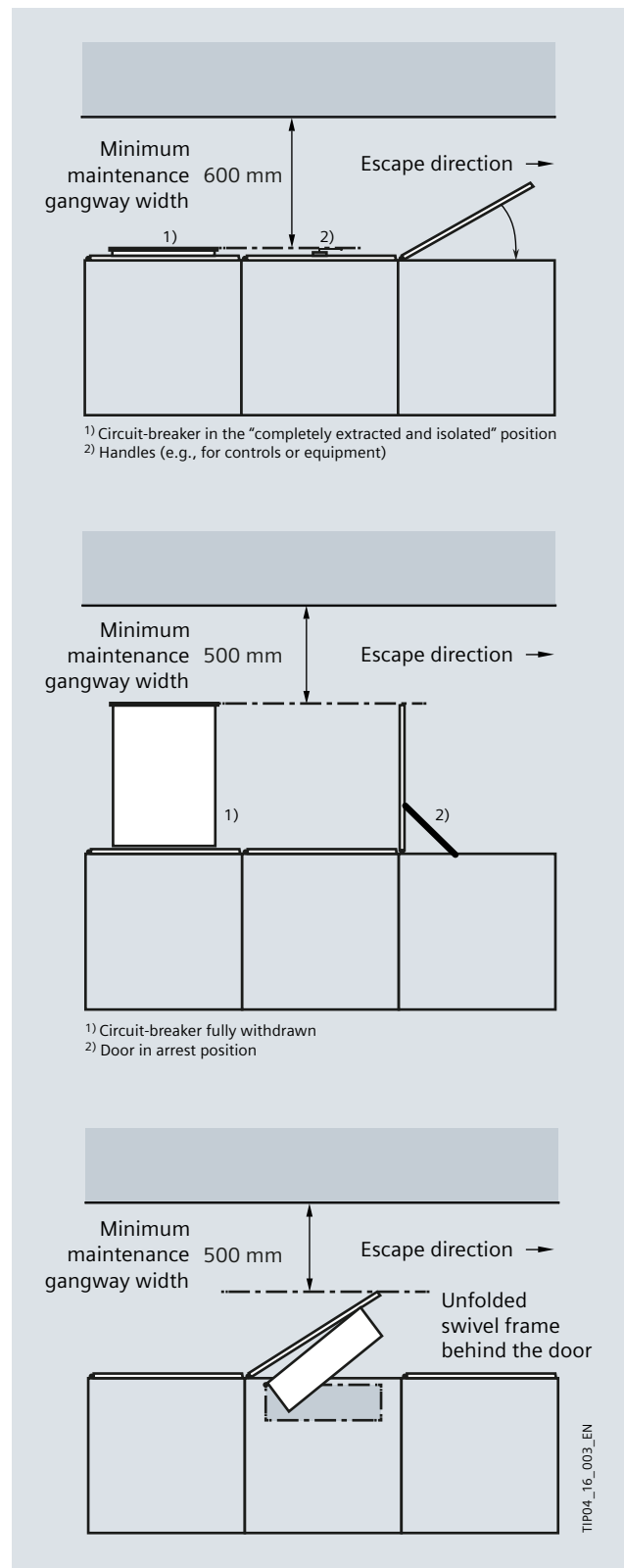

Fig. 10/6: Minimum widths of maintenance gangways in accordance with IEC 60364-7-729 (VDE 0100-729)

### Single-front and double-front systems

In the single-front system, the switchboard cubicles stand next to each other in a row (Fig. 10/7 top). One or more cubicles can be combined into a transport unit. Cubicles within a transport unit have a horizontal through-busbar. Cubicles cannot be separated.

In the double-front system, the cubicles stand in a row next to and behind one another (Fig. 10/7). Double-front systems are only feasible with a rear busbar position. The main feature of a double-front installation is its extremely economical design: the branch circuits on both operating cubicles are supplied by one main busbar system only.

A double-front unit consists of a minimum of two and a maximum of four cubicles. The width of the double-front unit is determined by the widest cubicle (1) within the double-front unit. This cubicle can be placed at the front or rear side of the double-front unit. Up to three more cubicles (2), (3), (4) can be placed at the opposite side. The sum of the cubicle widths (2) to (4) must be equal to the width of the widest cubicle (1).

One or more double-front units can be combined into a transport unit. Cubicles within a transport unit have a horizontal through-busbar. Cubicles cannot be separated.

Apart from the following exceptions, a cubicle composition within a double-front unit is possible for all designs. The following cubicles determine the width of the double-front unit as cubicle (1) and should only be combined with a cubicle for customized solutions without cubicle busbar system:

- Circuit-breaker design – longitudinal coupler
- Circuit-breaker design – incoming/outgoing feeder 4,000 A, cubicle width 800 mm
- Circuit-breaker design – incoming/outgoing feeder 5,000 A
- Circuit-breaker design – incoming/outgoing feeder 6,300 A

Cubicles with a width of 350 mm or 850 mm are not provided for within double-front systems.

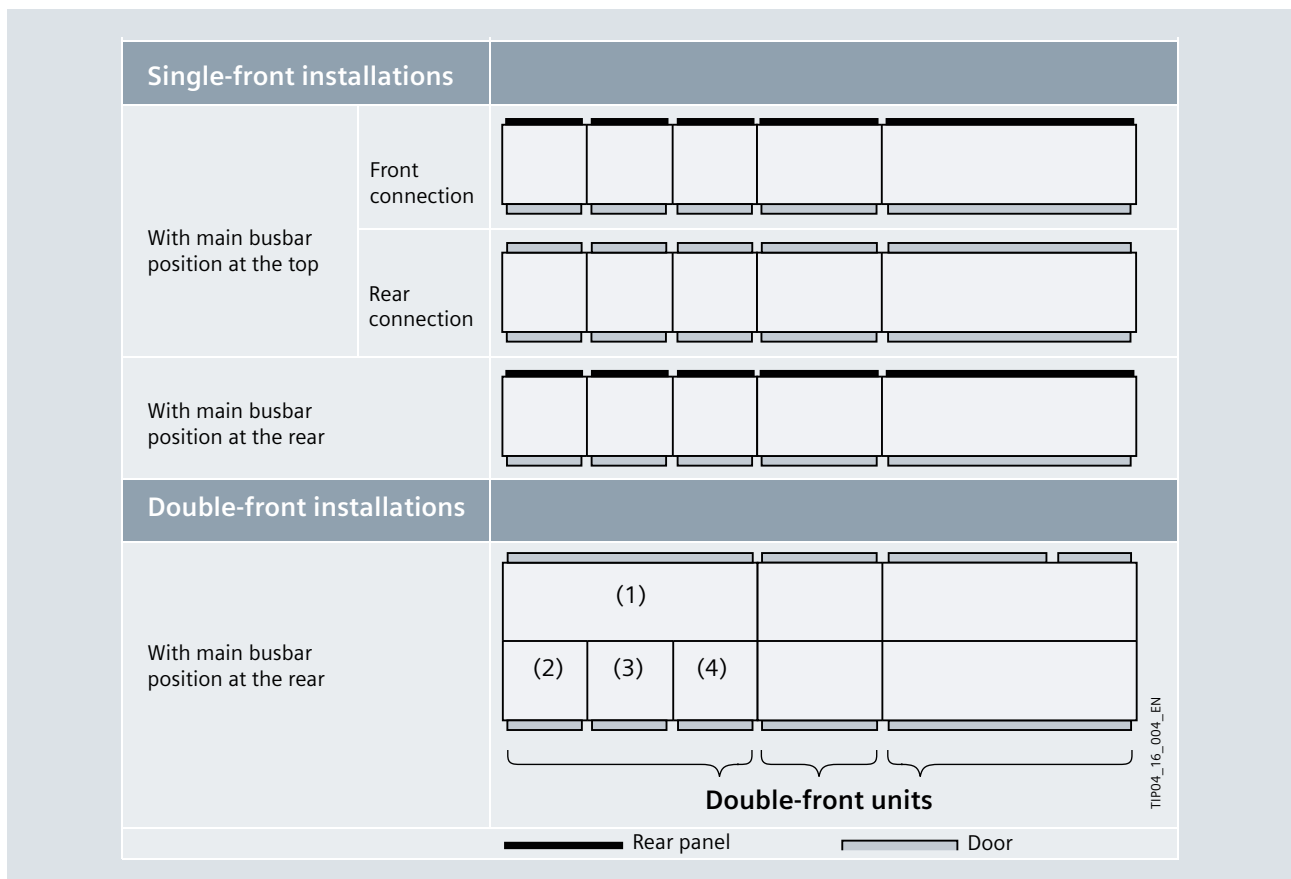

Fig. 10/7: Cubicle arrangement for double-front installations

### Safety against arc faults

As for transformers and medium-voltage switchgear, an arc fault occurring in the low-voltage switchgear can lead to dangerous interferences with serious consequences and damage neighbouring outgoing feeders, cubicles or even the entire installation. Arc faults may arise from wrong dimensioning, insulation deterioration such as pollution, but also from handling faults. High pressure and extremely high temperatures can have fatal consequences for the operator and installation, these consequences may even extend to the entire building.

The testing of low-voltage switchgear under arc fault conditions is a special test in compliance with IEC/TR 61641 (VDE 0660-500, Addendum 2). For the Siemens SIVACON S8 switchgear, the proof of safety of persons was furnished by the test under arc fault conditions.

Active protection measures such as high-quality insulation of live parts (for example, busbars), uniform and easy handling, integrated operator fault protection, and correct switchgear dimensioning prevent arc faults and hence personal injuries. Passive protection measures increase operator and installation safety many times over. They include arc-fault-proof hinge and lock systems, safe handling of withdrawable units or circuit-breakers only when the door is closed, and flap traps (SIVACON switchgear uses a patented system that is highly reliable) behind front air vents, arc barriers or an arc fault detection system in combination with a fast interruption of arc faults. The effectiveness of these measures is proven by numerous elaborate arc fault tests under worst case conditions on various cubicle types and functional units.

The arc fault levels (Fig. 10/8) describe the classification according to the properties under arc fault conditions and the limitation of the effects of an arc fault on the installation or parts thereof.

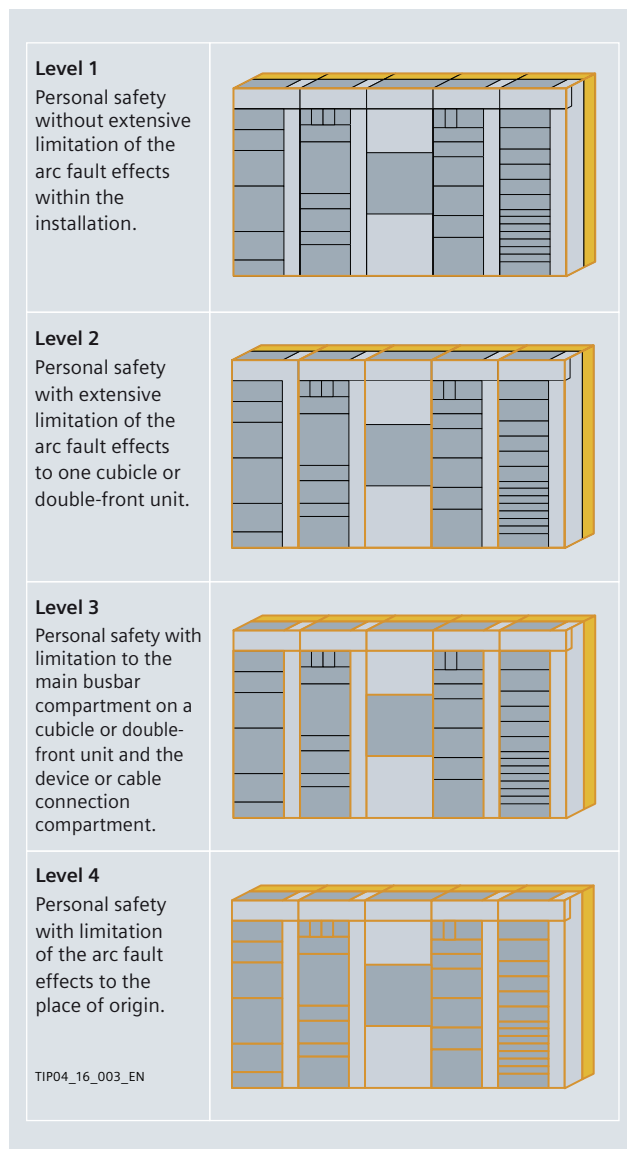

Fig. 10/8: Arc fault levels (installation segments to which the arcing fault is limited are shown orange)

**Reducing the occurrence probability of an arc fault**

In the intensive discussion about arc fault detection or interruption, technically elaborate and expensive solutions are readily propagated. Siemens, however, has for a long time preferred the prevention of arc faults by means of complete insulation (see Fig. 10/9) of all conductive parts inside the installation (busbars, connections, transfers, etc.). Such passive precautions ensure that no arc is generated that would have to be detected and quenched.

Active systems for the detection and interruption of an internal arc as a consequence of a fault need maintenance and do not provide any advantages with regard to the installation availability. The impacts of an arc fault (pollution, metal splashes, etc.) might be minor, but they usually have to be cleared nevertheless. Moreover, the interruption device of the active system has to be replaced. This work can be laborious and time-consuming. In 80 % of the cases, switchgear is installed at the wall. With a corresponding form of internal separation, the busbars are compartmentalized separately, which boosts the downtime and the effort for simple cleaning or for replacement (dismounting of the affected cubicle, possibly dismounting of the installation, to get to the main busbars).

Monitoring of the outgoing feeder areas of the switchgear is not recommended for active systems for reasons of reliability of supply, as arc faults in these areas should be interrupted by the upstream protection device. Otherwise, such a fault would lead to a complete shutdown of the installation.

For feed-in monitoring (terminal compartment), the system must act on the upstream protection device. Thus, the advantage of a fast interruption by the active system is lost in the case of such a fault. Although Siemens offers an active system for arc fault detection and interruption, it favours the passive system (complete insulation of busbars and connections) which is more advantageous for the customer for the following reasons:

- Economic aspects such as investment and service costs; they are much more favourable
- Increased installation availability; downtimes next to zero
- Improved safety of persons
- Operational reliability higher than that of a function-controlled, active system
- Incoming and outgoing feeder areas (inclusive of the compartments in the case of a withdrawable-unit design) and busbar compartments can be insulated
- Many years of positive experience with the passive protection system

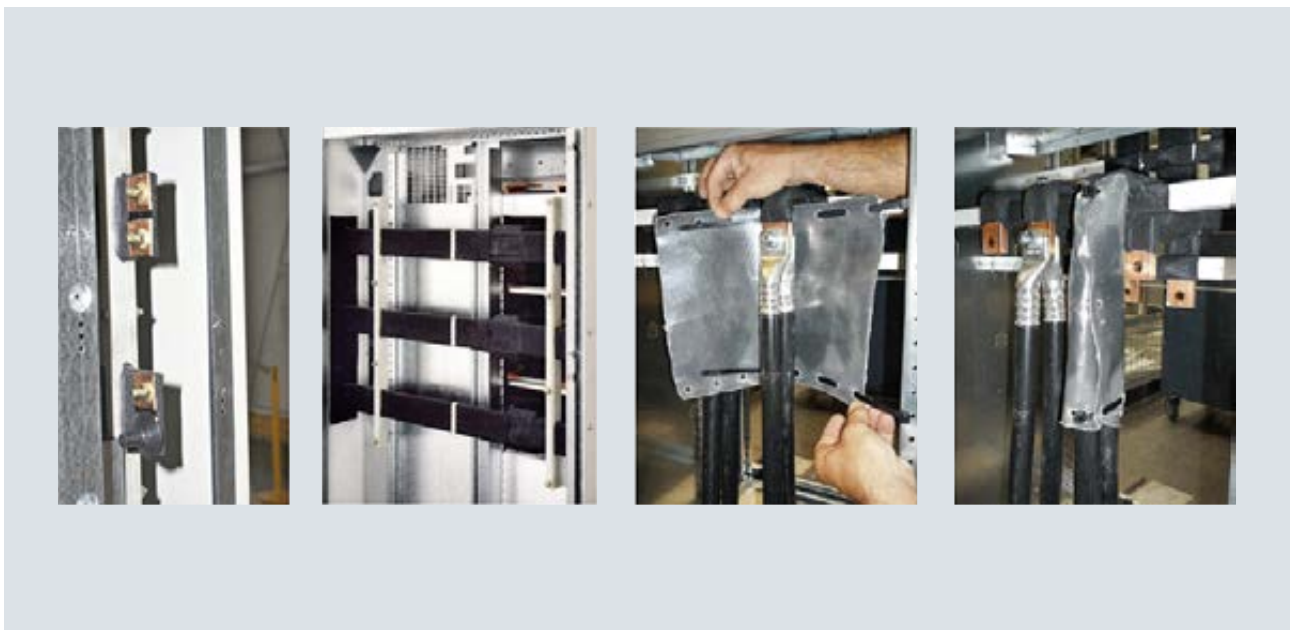

Fig. 10/9: Passive system to prevent arcing faults with insulated busbar, panel connector, incoming and outgoing feeder

### 10.3 Motor Control Centre

If motor drives are available, low-voltage switchgear installations are used as motor control centres (MCC). The MCC panels are available in fixed-mounted or withdrawable-unit design and equipped with a door-locking main switch and motor starter combination. Each main switch has motor switching capacity (6 to 8 times the rated current  $I_r$  of the motor) and disconnecting capacity so that opening the panel door in front of the withdrawable unit is only possible after switch-off.

Power contactors are used for operational motor switch-on and -off because of the high switching frequency of motor branch circuits. The following is used:

- Direct contactors for normal start-up
- Contactor combinations for reversal circuits
- Contactor combinations for star-delta start-up circuits

Overload and short-circuit protection of the motor branch circuits can be implemented in circuit-breaker-protected as well as in fuse-protected design.

- Circuit-breaker-protected design
  - with circuit-breaker for short-circuit and overload protection
  - with circuit-breaker (for short-circuit protection) and overload relay (thermal or electronic for overload protection)
- Fuse-protected design with fuse-switch-disconnectors (the fuses take on the short-circuit protection) and overload relay (thermal and electronic for overload protection)

### 10.4 Distribution Boards

In compliance with IEC 61439-3 (VDE 0660-600-3), distribution boards are defined as switchgear assemblies in electric power distribution intended to be operated by ordinary persons (DBO). They are to meet the following criteria:

- Operation by ordinary persons is possible, for example, in home use
- The outgoing circuits contain short-circuit protection equipment
- The rated voltage  $U_n$  to earth is 300 V AC max.
- The rated current  $I_n$  of the outgoing feeders is 125 A max. and  $I_n$  of the switchgear assemblies is 250 A max.
- A closed, stationary enclosure is intended for use in electric power distribution
- Indoor and outdoor installation is possible
- They must comply with overvoltage category III minimum (see IEC 60439-1; VDE 0660-600-1)

A differentiation is made between

- DBO type A with a busbar arrangement to hold 1-pole equipment
- DBO type B with a busbar arrangement to hold 1-pole and/or multi-pole equipment

#### Rated diversity factor

For DBO, the manufacturer of switchgear assemblies is to specify rated diversity factors (RDF). In IEC 61439-1 (VDE 0660-600-1), the RDF is defined as “rated current, assigned by the assembly manufacturer, to which outgoing circuits of an assembly can be continuously and simultaneously loaded taking into account the mutual thermal influences”. Thus, it is to be considered that multiple functional units of the DBO are loaded alternately or not concurrently.

If no RDF is specified by the manufacturer, it can be assumed dependent on the number of outgoing circuits in compliance with IEC 61439-3 (VDE 0660-600-3) (Tab. 10/4).

Number of outgoing circuits	Rated diversity factor (RDF)
2 and 3	0.8
4 and 5	0.7
6 to 9 includingly	0.6
10 and more	0.5

Tab. 10/4: Rated diversity factors (RDF) for DBO in acc. with IEC 61439-3 (VDE 0660-600-3)

The following aspects are particularly important for the configuration:

**Environmental and installation conditions, mechanical stress**

- Degree of protection in acc. with EN 60529 (VDE 0470-1) protection against contact, dust and water protection
- Ambient temperature and climatic conditions
- Corrosion
- Type of installation and fastening (for example, stand-alone, on the wall)
- Cover or doors (as appropriate transparent or non-transparent)
- Dimensions, weight
  - Maximum permissible outer dimensions of the switchgear
  - Maximum permissible dimensions and weight of the switchgear for transport and erection at the site of installation
- Cable duct (base panelling, if required)
- Cable glands
- Type of cable laying (cable duct, cable racks, etc.)
- Device installation (fixed or plug-in / withdrawable units for quick replacement)
- Accessibility of devices:
 

Parts that can be operated during operation (such as fuses or miniature circuit-breakers) are to be combined and arranged within the switchgear assembly in such a way that they are separately accessible (via a quick-release cover, for example). Contactors and fuses are to be placed in separate boxes

**Type of installation, accessibility**

To ensure that the most economical design can always be selected, the main features of the switchgear and distribution boards should be weighed against each other and a decision be made before defining the structural measures. Such features are:

- Open or closed design (kind of operating site)
- Self-supporting installation:
  - stand-alone in the room, at a wall or in a wall recess
- Not self-supporting installation:
  - for mounting to the wall, to a supporting frame or in a wall recess
- Kind of accessibility for installation, maintenance, and operation
- Dimensions (installation height, depth, width)
- Notes regarding structural measures

**Selection of the electrical equipment**

The following has to be considered for the equipment to be installed in switchgear assemblies:

- The applicable device specifications
- The suitability with regard to nominal data, in particular short-circuit strength and breaking capacity
- The installation of current-limiting protection equipment might be necessary

**Protection measures**

- Protection against direct contact in the distribution board when the door is open by means of contact protection covers, degree of protection IP30
- Protection against indirect contact at all frame and cladding parts by means of
  - Safety class I (protection conductor connection)
 

Encapsulations and parts of the supporting structure made of metal are protected against corrosion by means of an high-quality surface protection. Metal parts of switchgear and distribution boards are to be included in the protection measure by means of a protection conductor
  - Safety class II (protection insulation)
 

If switchgear or distribution boards of safety class II are used, it has to be ensured that the factory-provided protection insulation is by no means punctuated by conductive metal parts such as switch axes, metal line adapters, screws, etc. The inactive metal parts within the protection insulation such as base plates and device enclosures must never be connected with the PE or PEN conductor, even if they provide a PE terminal screw. If covers or doors can be opened without any tool or key, all internal accessible conductive parts must be arranged behind a cover made of insulating material in degree of protection IP2X. These covers must only be removable with the help of a tool. Looping in PE conductors is permitted

### Space requirements for built-in units, busbars and terminals

When configuring built-in components in encapsulated switchgear and distribution boards, in particular in box-type distributors, sufficient space must be provided beyond the pure space requirements of the units for:

- The electrical clearance (clearance in air) to the encapsulation
- The heat dissipation of the individual units
- A possibly required blow-out room in switching devices
- The wiring
- The connection of external incoming and outgoing feeder cables (terminal compartment)
- The device identification

In the project documentation as well as in the completed switchgear assembly, the devices belonging together have to be designated clearly. This also applies to the assignment of fuses to circuits.

Meters and measuring instruments should be located at eye level. All devices that are to be operated manually should be within reach (approximately at a height between 0.6 and 1.8 m). Restrictions resulting from the use of a device in an encapsulation might have to be observed, for example, with regard to the rated current and the switching capacity.

Distribution boards are available in flush-mounted or surface-mounted design and as floor-mounted cabinets (see Fig. 10/10). Sub-distribution boards are often installed in confined spaces, recesses or narrow corridors. This often results in a high device packing density. In order to prevent device failures or even fire caused by excess temperatures, special attention must be paid to the permissible power loss referred to the distribution board size, its degree of protection and the ambient temperature.

### Connection compartments

After the installation of the switchgear and distribution boards, the space available in the internal or external connection compartment for outgoing cables and wires is decisive for the efficient workflow of connection work. At first, a particularly small encapsulation appears to be very economical because of the low purchase price. However, due to the confined space, the installation expenses can be so high when connecting cables and wires the first time and later that this cost advantage is lost. For cables with a large cross section, make sure that there is enough space to spread the wires and for routing the cable.

Important factors for the selection and arrangement of the sub-distribution boards are the number and position resulting from the planning modules (refer to chapter 3), as the costs for the cabling also play a role. It is also possible to use busbars as an alternative to cable laying and subdivision into sub-distribution boards.

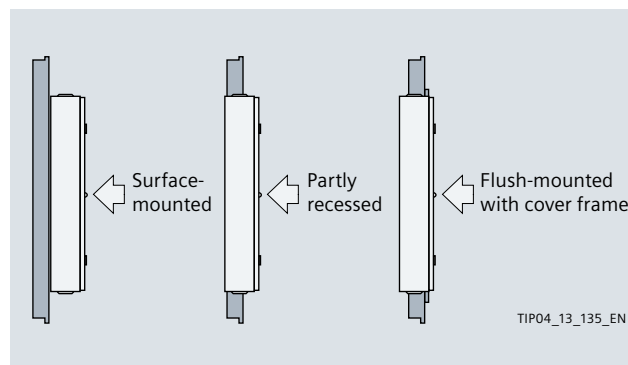

Fig. 10/10: Mounting options for wall-mounted distribution boards

## 10.5 Busbar Trunking Systems

As line distribution boards (see Fig. 10/11), busbar trunking systems (BTS) also belong to the group of switchgear assemblies documented in IEC 61439 (VDE 0660-600). Apart from the general requirements of IEC 61439-1 (VDE 0660-600-1), the required product features of BTS are described in IEC 61439-6 (VDE 0660-600-6) in particular. The rated voltage must not exceed 1,000 V for alternating voltage and 1,500 V for direct voltage. BTS can not only be operated in combination with the other components of the electric power distribution system, but they can also be linked with the generation, transmission and conversion of electric power and with the control of power consumers. Excluded from IEC 61439-6 (VDE 0660-600-6) are, among others, electrical busbar systems for luminaires (in accordance with IEC 60570; VDE 0711-300). However, lighting systems can be connected to BTS and communication-capable tap-off units can be used to control consumers and to switch luminaires (see Fig. 10/11).

Planning is based on the incoming power (for example, rated and short-circuit currents of the feeding transformers) and connection values of the BTS and additionally on the following data:

- Permissible voltage drop
- Required degree of protection
- Power system configuration
- Weighing of the supply concepts as cable system or busbar trunking system
- Short-circuit strength
- Overload and short-circuit protection

### Configuration

Depending on the project conditions, different busbar trunking systems can be selected:

- Sandwich design for compact dimensions
- Ventilated busbar design for excellent heat dissipation (Attention: In the case of rising mains, the stack-effect of a closed box-type system may provide advantages)
- Moulded busbar trunking system if highest demands are made on the degree of protection in critical environments

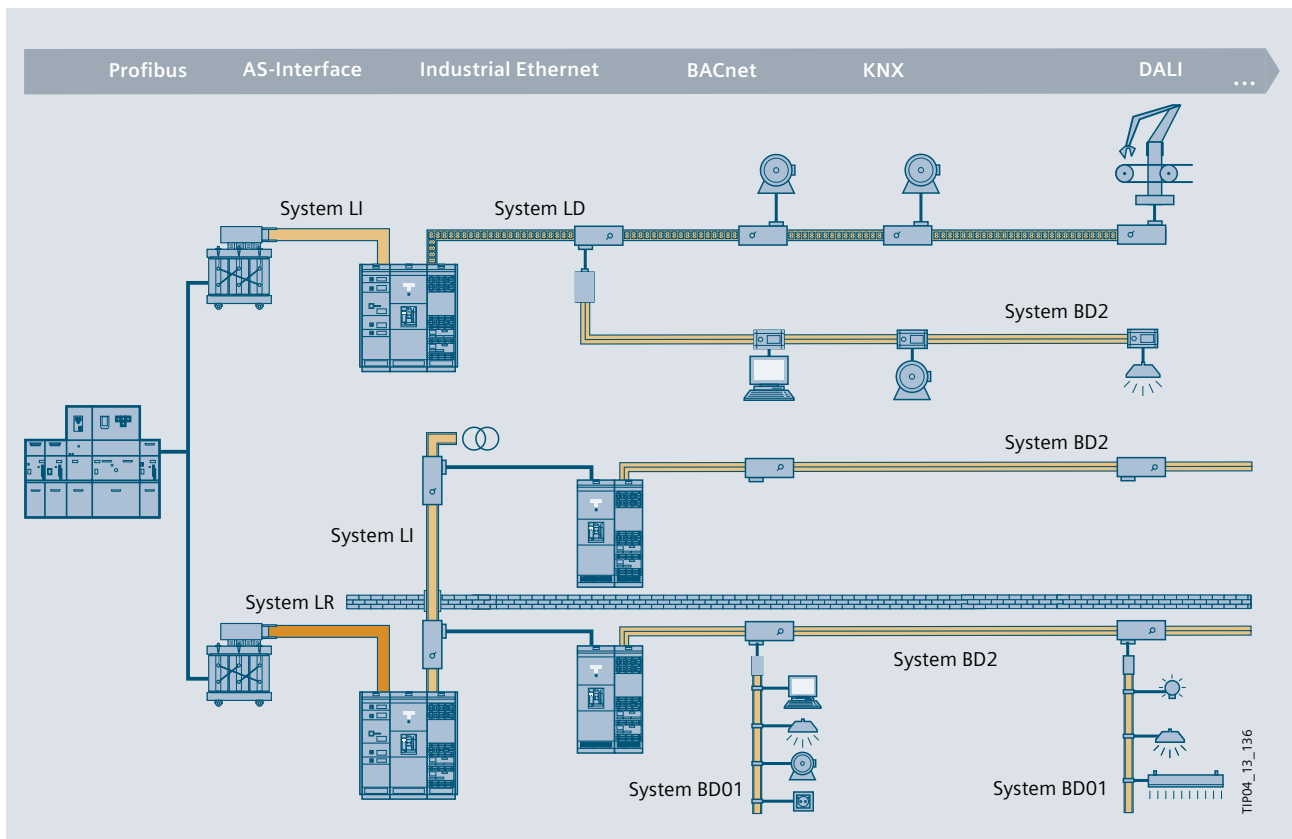

Fig. 10/11: SIVACON 8PS busbar trunking systems for different requirements and loads



The various systems may include different numbers of conductors. The PE conductor can be implemented as a separate busbar or as an enclosure. The N conductor can be a single conductor or it can be duplicated. As shown in chapter 5, the conductors can be routed doubly in an enclosure to improve EMC.

### Conductor material

Aluminium and copper are possible conductor materials. In the three years from 2010 to 2012, the copper price rose from about 4,000 to 6,000 euros per ton, the price for aluminium from about 1,300 to 1,600 € per ton<sup>1)</sup>. However, if aluminium is to be used as conductor material, the approximately 60 % larger conductor cross sections make a significant difference, which are required due to the lower electrical conductivity compared to copper. On the other hand, aluminium is about 35 % lighter than copper.

If aluminium is used, the necessary larger cross sections require more space. While this is immaterial in HV power lines, it might be the knock-out criterion in a densely equipped switchgear cabinet or if routing busbar trunking systems in buildings. No criterion, however, is the oxidation capability of aluminium, as the aluminium buses from Siemens are tin-plated so that there is no air-aluminium contact and the infamous disposition to flowing of aluminium cannot loosen the screw connections.

A rough clue for the use of the two materials is provided by the estimations of the material-specific relations as ratio:

- Market price for raw material Cu to Al is as 3 : 1
- Weight of Cu to Al is as 3 : 1
- Volumetric specific resistance (1 / electrical conductivity) is as 3 : 5
- Mass-related specific resistance (1 / electrical conductivity) is as 2 : 1
- Output-related costs per ampere (transmitted power) is as 5 : 1

### Power transmission

Busbar trunking units without tap-off points are used for power transmission. They are available in standard lengths and custom lengths. Besides the standard lengths, the customer can also choose a specific length from various length ranges to suit individual constructive requirements.

Upwards of a rated current of approximately 1,600 A, busbars have a significant advantage over cables and wires in the material and installation prices as well as in the costs for additional material such as cable terminations or for wall bushings. Both these costs and the time benefits during installation increase with the rated current rising. [Tab. 10/6](#) summarizes the major differences between cable installations and busbar trunking systems.

### Variable power distribution

In busbar trunking systems, electricity cannot just be tapped from a permanently fixed point as with a cable installation. Tapping points can be varied and changed as desired within the entire power distribution system. In order to tap electricity, you just have to connect a tap-off unit to the busbar system at the tapping point. This way, a variable distribution system is created for linear and/or area-wide, decentralised power distribution. Tap-off points are provided on just one or either side of the straight busbar trunking units. For each busbar trunking system, a wide range of tap-off units is available for the connection of consumers and electricity supply.

### Fire protection

The following must be taken into account as to fire protection:

- Reduction of the fire load
- Prevention of fire spreading

The entire length has to be considered because the electrical routing may run through the whole building and is used to supply special installations and systems as for instance:

- Lifts with evacuation system
- Fire alarm systems
- Emergency power supply systems
- Ventilation systems for safety stairways, lift wells, and machine rooms of fire brigade lifts
- Systems to increase the pressure of the water supply for fire fighting
- Emergency lighting

"In order to prevent the development and spreading of fire and smoke, and to be able to effectively extinguish fires and save people and animals in the event of a fire" (state building regulations in Germany), neither fire nor flue gas

<sup>1)</sup> E-Installation, 2<sup>nd</sup> Edition 2012; Siemens AG

may spread from one floor or fire section to another. For busbar trunking systems, the fire walls between the various fire areas in the building complying with fire resistance classes S60, S90, and S120 in accordance with DIN 4102-9 can be ordered together with the busbar trunking system, depending on the design and type. The fire walls must have at least the same fire resistance class as the relevant wall or ceiling.

It may be necessary to provide additional protection housing for the trunk line in the room for reasons of functional endurance. Depending on the required functional endurance class and the planned carrier/support system, different design variants are offered with Promatect boards (encapsulation on 2, 3 or 4 sides, refer to Fig. 10/12). Because of the poorer ventilation and heat dissipation through the protection housing, the reduction factors specified by the manufacturers must be taken into account in later planning steps in order to determine the maximum permissible currents. A reduction factor of 0.5 can be assumed for an initial estimation.

Contrary to inexpensive cables and wires, the insulation used in BTS does not contain any materials that produce corrosive or poisonous gases in the event of a fire. There is also no burning of material in BTS so that the rooms remain clean and the escape routes are not impeded.

As for low-voltage switchgear, a design verification can be accomplished for BTS. The design verification is accomplished dependent on the examined characteristic by way of testing, calculation, and construction verification (see Tab. 10/5).

Compared to the conventional cable installation, BTS provide many advantages with regard to network and installation technology, as depicted in Tab. 10/6.

For demonstration purposes, Fig. 10/13 shows wirings for simple electric power distribution systems. Modification and retrofitting of an electric power distribution system usually mean significantly higher expenditures of time and money for cable installations than for BTS.

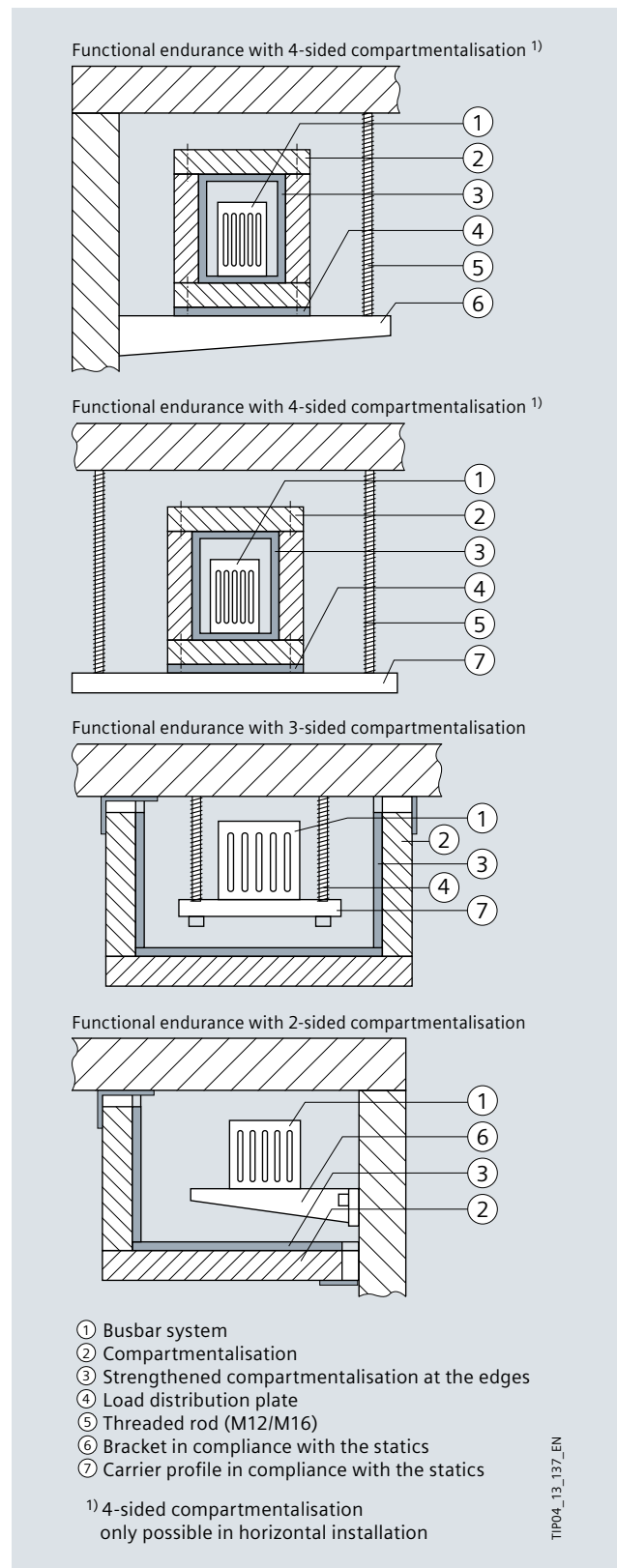

Fig. 10/12: Functional endurance through compartmentalisation

Characteristics to be verified	Verification by ...		
	Testing	Calculation	Construction rules
<b>Strength of materials and parts:</b>			
Corrosion resistance	Yes	No	No
<b>Insulation material properties:</b>			
Resistance of insulation material to heat	No	No	Yes
Heat resistance	Yes	No	No
Resistance to extraordinary heat and fire due to internal electrical effects	Yes	No	Yes
Resistance to UV radiation	Yes	No	Yes
Impact test	Yes	No	No
Labels	Yes	No	No
Resistance to mechanical load	Yes	No	No
Tests with thermal cycles	Yes	No	No
Degree of protection of enclosures	Yes	No	Yes
Clearances in air	Yes	No	Yes
Creepage distances	No	No	Yes
<b>Protection against electric shock and continuity of protection circuits:</b>			
Continuity of the connection between bodies of the BTS and the protection circuit	Yes	No	No
Short-circuit strength of the protection circuit	Yes	No	No
Installation of equipment	No	No	Yes
Internal electric circuits and connections	No	No	Yes
Connections for conductors entered from the outside	No	No	Yes
<b>Insulation properties:</b>			
Operating frequency withstand voltage	Yes	No	No
Impulse withstand voltage	Yes	No	Yes
Heating limits	Yes	Yes	No
Short-circuit strength	Yes	Yes	No
Electromagnetic compatibility (EMC)	Yes	No	Yes
Mechanical function	Yes	No	No
Resistance to fire spreading	Yes	No	No
Fire resistance time of busbar trunking units with fire walls	Yes	No	No

Tab. 10/5: Design verification for BTS in acc. with IEC 61439-6 (VDE 0660-6)

[back to page 230](#)

1

2

3

4

5

6

7

8

9

10

11

12

13

14

15

16

17

Characteristic	Busbar trunking system	Cable installation
Network configuration	Linear configuration with serially arranged consumer outlets via tap-off units	High accumulation of cables at the feed-in point due to the radial supply to the consumers
Operational safety	Design verified in accordance with IEC 61439-6 (VDE 0660-6)	Dependent on the respective design quality
Flexibility	Variably usable tap-off units which can be retrofitted and replaced; also live assembly work possible	Great effort due to splices, clamping points, sleeves, parallel lines, etc.; assembly work only possible in the de-energized state
Fire load	Very low fire load	PVC cable: fire load up to 10 times greater than in BTS PE cable: fire load up to 30 times greater than in BTS
Electromagnetic interference	Sheet steel encapsulation	Strong interference with standard cables; strongly dependent on the kind of bundling with single-conductor cables
Current carrying capacity	High current carrying capacity	Type of installation, accumulation, and operating conditions determine limit values
Freedom from halogen/PVC	Busbar trunking units are always halogen-free	Standard cables are not halogen/PVC-free; halogen-free cables are expensive
Space requirements	Compact design due to high current carrying capacity; standard angle and offset elements	Large space requirements due to bending radii, type of installation, accumulation, and current carrying capacity
Weight	Compared to cable, weight reduction to the half or even one third	Weight up to 3 times higher than that of a comparable BTS
Installation	Uncomplicated installation possible with simple auxiliary tools and short installation times	Laborious installation only possible with numerous auxiliary tools; considerably longer installation times

Tab. 10/6: Comparison of characteristics of BTS and conventional cable installation

[back to page 229](#)

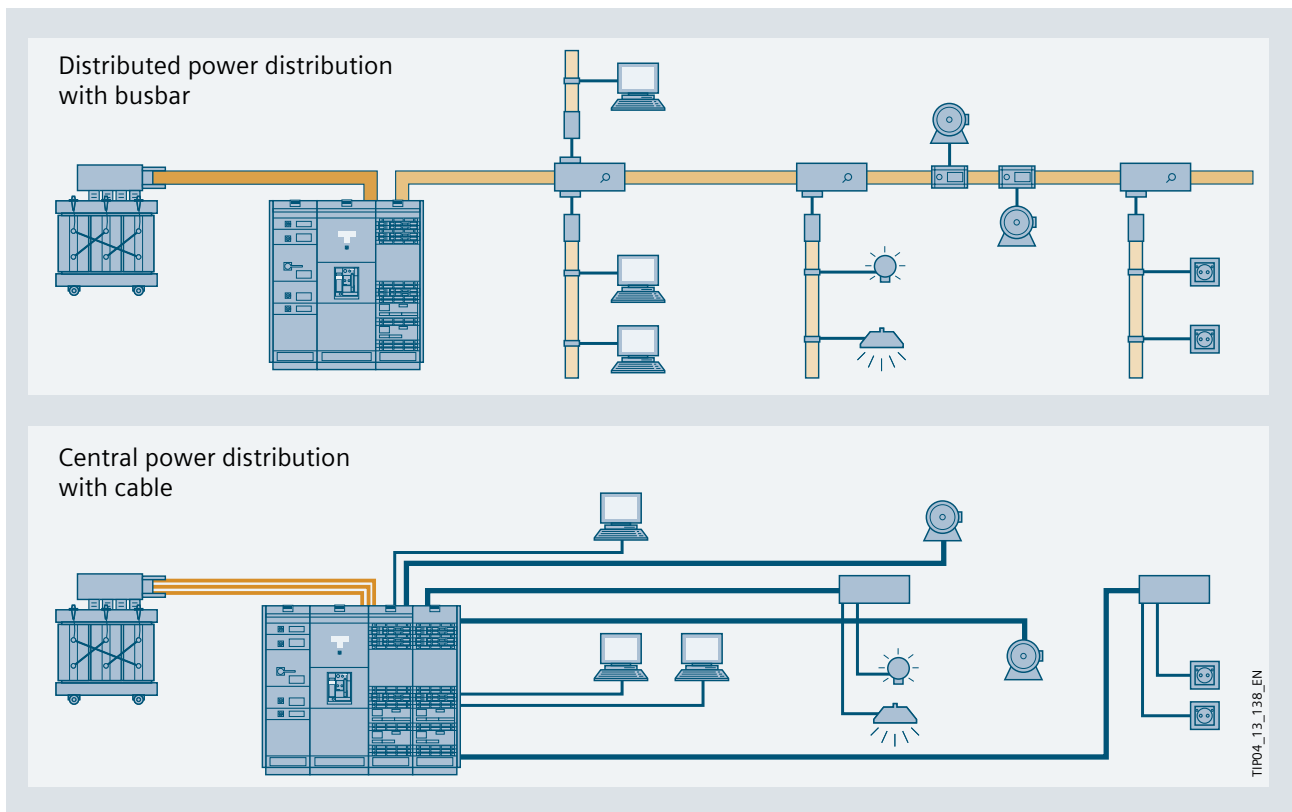

Fig. 10/13: Comparison of wirings for cable installation and BTS

[back to page 230](#)



# Chapter 11

## Low-voltage Protection and Switching Devices

11.1	Circuits and Device Assignment	236
11.2	Requirements on the Protection Devices in the Three Circuit Types	237
11.3	Residual Current and Arc Fault Detection Devices	240

# 11 Low-voltage Protection and Switching Devices

1  
2  
3  
4  
5  
6  
7  
8  
9  
10  
11  
12  
13  
14  
15  
16  
17

When low-voltage power system protection is parametrised and coordinated, the fast and reliable detection of fault types and fault locations as well as a selective isolation of the faulted grid sections and installation parts from the interconnected grid are predominant aspects. For this reason, low-voltage protection and switching devices must fulfil the following functions:

- Overcurrent protection
  - Short-circuit protection
  - Overload protection
- Overtemperature protection

Device selection must correspond to the widely varying protection tasks the devices have to fulfil, such as cable and line protection, personal safety, fire protection, lightning current and overvoltage protection, as well as equipment and system protection (Fig. 11/1):

- Circuit-breakers protect systems, motors, generators, and transformers against overload and short circuit in the event of a fault. They are also used as incoming and outgoing feeders in distribution boards as well as main switch and EMERGENCY OFF switch in combination with lockable rotary operating mechanisms
- Residual current devices and arc-fault detection units are used for personal safety and fire protection:
  - Personal safety
 

Damage in the insulation may result in fault conditions which require additional measures in compliance with IEC 60364-1 (VDE 0100-100) against excessive shock currents. The optimal protection against hazardous shock currents in case of indirect or – to the greatest possible extent also in case of direct – contact with live parts (rated fault currents  $\leq 30$  mA) is attained with residual current devices
  - Fire protection
 

A fire risk prevails in the event of a short circuit or earth fault in particular if relatively high resistances are present at the arc-fault location in the faulted circuit. Fault clearing by means of upstream overcurrent protection devices such as a fuse or circuit-breaker is not always ensured in case of relatively low currents. A heat output of only 60 W might lead to the situation, if oxygen or air is present, that the ignition point is reached. In such a situation, too, a residual current device with a rated fault current  $\leq 300$  mA, or even better an arc-fault detection unit provides all-embracing safety

- Miniature circuit-breakers and fuses are mainly used as cable and line protection. Operator safety and mounting safety are the fundamental prerequisites for their use. Fitting a residual current unit additionally allows the fault-current protection function to be integrated
- Disconnectors permit the safe isolation of downstream installation parts and equipment. They are used as EMERGENCY OFF and repair switches in distribution boards, for example. Therefore, personal safety is the predominant aspect. In the 'open' position, they meet the requirements defined for the disconnect function
- Well-matched combinations of circuit-breakers, fuses, miniature circuit-breakers, and residual current devices ensure comprehensive system protection in terms of short-circuit, overload, and fire protection. Above that, the electrical installation can be protected against overvoltages as a result of electrostatic discharges, switching overvoltages, and strikes of lightning by the coordinated use of lightning current and surge arresters. Optimal system protection in one of these areas of application is ensured by matching the individual components. Damage to increasingly expensive and sensitive equipment is thus reliably prevented

Siemens switching and protection devices (portfolio excerpt)

Circuit-breakers



3WL air circuit-breakers

3VL, 3VA moulded-case circuit-breakers

3RV circuit-breaker for motor protection

Miniature circuit-breaker, contactor, and surge arrester



5SL miniature circuit-breaker

5TT5 Insta contactor

5SD7 surge arrester

Fault current and fire protection devices



5SM3 residual current operated circuit-breaker

5SM6 arc-fault detection unit

Fuse systems



NEOZED fuse system

DIAZED fuse system

LV HRC fuse system

SITOR semiconductor fuses

Switch-disconnector with and without fuses



3LD EMERGENCY STOP switch

3KA, 3KD switch-disconnector without LV HRC fuses

3NJ6 switch-disconnector with LV HRC fuses, in-line type

3NP LV HRC fuse-switch-disconnector

3NJ4 LV HRC fuse-switch-disconnector, in-line type

TIP04\_13\_173\_EN

Fig. 11/1: Overview of switching devices and protection devices

[back to page 234](#)

## 11.1 Circuits and Device Assignment

Switching and protection devices can be assigned to the low-voltage power distribution circuits described in chapter 6 according to their core functions and technical features. This is summarized in Tab. 11/1. Personal safety must be ensured for all circuits. Fig. 11/2 demonstrates the circuit assignment of switching and protection devices with pictograms.

The most important criteria for switching and protection device selection are:

- Type of application for example system, motor, disconnecter
- 3- or 4-phase design
- Mounting, for example fixed mounting, plug-in or withdrawable-unit design
- Nominal current  $I_n$  for example ACB: 6,300 A; MCCB: 1,600 A; fuse: 630 A
- Rated ultimate short-circuit breaking capacity  $I_{cu}$

Circuit	Task	Protection device
Supply circuit	System protection	Air circuit-breaker (ACB)
Distribution circuit	System protection	Air circuit-breaker (ACB) Moulded-case circuit-breaker (MCCB) Fuse-switch-disconnector (Si-LT) Switch-disconnector with fuse (LT-Si)
Final circuit	Motor protection, equipment protection	Circuit-breaker for motor protection (MCCB) Fuse-switch-disconnector (Si-LT) Switch-disconnector with fuse (LT-Si) Motor starter protection (MSP)

Tab. 11/1: Circuit matrix for protection and switching devices in the low-voltage power distribution system

- Type of trip unit for example L, S or I (see chapter 6); electronic or thermo-magnetic; this influences selectivity and protection setting
- Communication options and data transfer

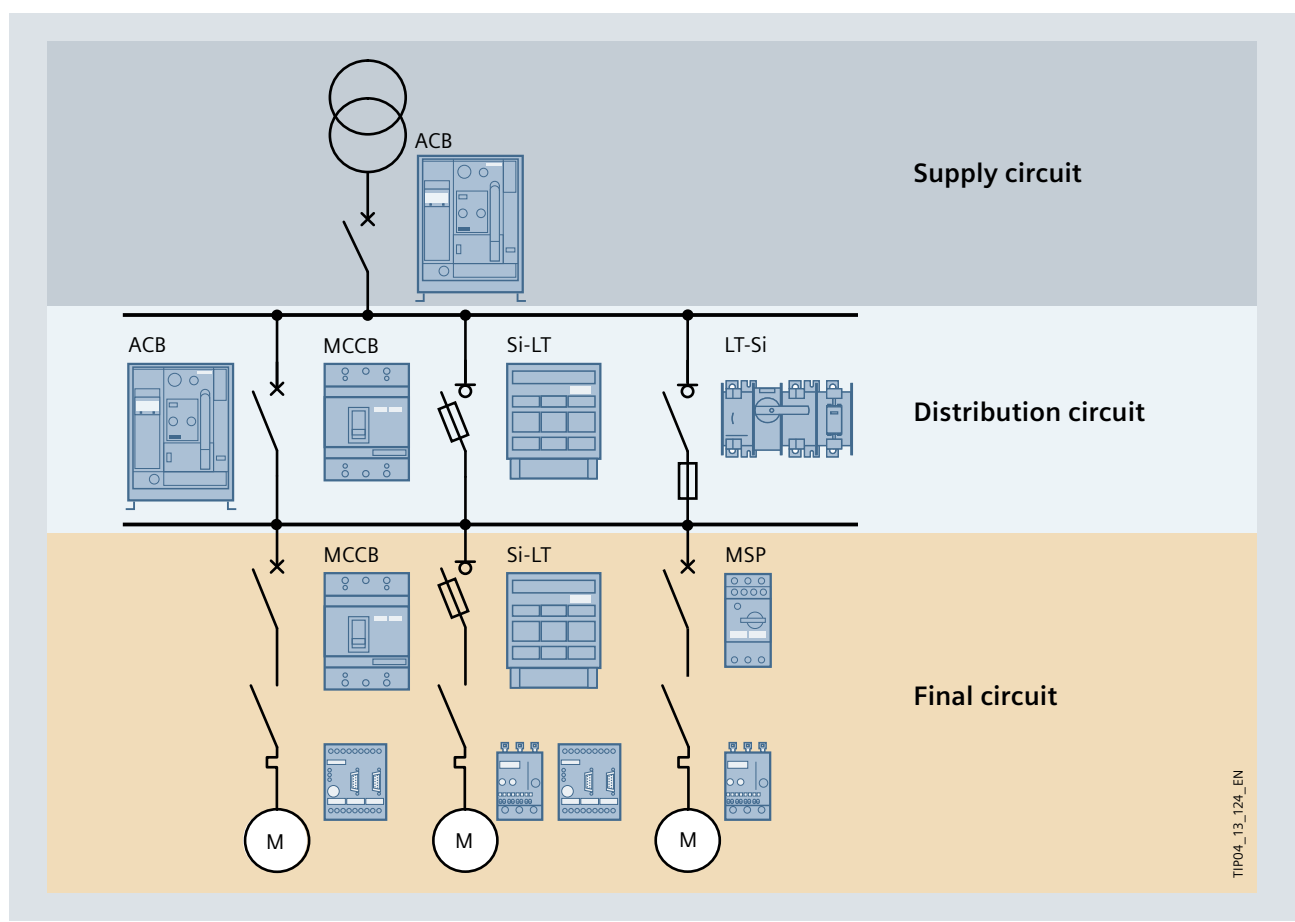

Fig. 11/2: Protection device matrix according to circuit type



## 11.2 Requirements on the Protection Devices in the Three Circuit Types

### 11.2.1 Use in the Supply Circuit

The system feed-in or supply circuit is the most “sensitive” circuit in the entire power distribution. A failure here would result in the entire network and therefore the building or production being without power. This worst-case scenario must be considered during the planning. Redundant system supplies and selective protection setting are important preconditions for a safe network configuration. Some important cornerstones for dimensioning and proper device selection are discussed in the following sections.

#### Rated current

The supply circuit-breaker in the low-voltage main distribution system (LVMD) must be dimensioned for the maximum load of the transformer/generator. When using ventilated transformers, the higher operating current of up to  $1.5 \cdot I_r$  of the transformer must be taken into account.

#### Short-circuit strength

The short-circuit strength of the supply circuit-breaker is determined as follows for transformers with identical electrical characteristics:

$$(n-1) \cdot I_{k \max} \text{ of transformer(s) (n = number of transformers)}$$

This means, the maximum short-circuit current that occurs at the installation position must be known in order to specify the appropriate short-circuit strength of the protection device ( $I_{cu}$ ). Exact short-circuit current calculations including attenuations of the medium-voltage levels or the laid cables can be made, for example, with the aid of the SIMARIS design dimensioning software (see chapter 15). SIMARIS design determines the maximum and minimum short-circuit currents and automatically dimension the correct protection devices.

#### Utilisation category

When dimensioning a selective network, time grading of the protection devices is often essential. When using time grading up to 500 ms, the selected circuit-breaker must be able to carry the short-circuit current that occurs for the set time. Close to the transformer, the currents are very high. This current carrying capacity is specified by the  $I_{cw}$  value (rated short-time withstand current) of the circuit-breaker; this means the contact system must be able to carry the maximum short-circuit current, meaning the energy con-

tained therein, until the circuit-breaker is tripped. This requirement is met by circuit-breakers of utilisation category B according to IEC 60947-2 (VDE 0660-101) (for example air circuit-breakers, ACB). Current-limiting circuit breakers (moulded-case circuit breakers, MCCB) trip during the current rise. They can therefore be constructed more compactly.

#### Trip units

If the network is designed to be selective, the trip unit of the supply circuit-breaker must show an LSI characteristic. It must be possible to deactivate the instantaneous release (I). Depending on the curve characteristic of the upstream and downstream protection devices, the characteristics of the supply circuit-breaker in the overload range (L) and also in the time-lag short-circuit range (S) should be optionally switchable ( $I^4t$  or  $I^2t$  characteristic curve). This facilitates the adaptation of upstream and downstream devices.

#### Internal accessories

Depending on the respective control, not only shunt trips but also undervoltage releases are required.

#### Communication

Very critical supply circuits, in particular, increasingly require the transmission of data concerning current operating states, maintenance information, fault indication, and analyses, etc. Flexibility may also be required with regard to subsequent expansion or modification to the desired type of data transmission.

### 11.2.2 Use in Couplings of a Switchgear Substation

If a coupling (connection of busbar sections) is operated in open state, the circuit-breaker merely functions as disconnect or main switch. A protection function (trip unit) is not necessarily required. The following considerations apply to closed operation.

#### Rated current

Must be dimensioned for the maximum possible operating current (load compensation).

#### Short-circuit strength

The short-circuit strength of the coupling switch is determined by the sum of the short-circuit components that flow through the coupling. This depends on the configuration of the component busbars and their supply.

## Utilisation category

As for the system supply, utilisation category B is also required for the current carrying capacity ( $I_{cw}$  value).

## Trip units

Partial shutdown with the couplings must be taken into consideration for the supply reliability. As the coupling and the supply circuit-breakers have the same current components when a fault occurs, similar to the parallel operation of two transformers, the LSI characteristic is required. The special zone-selective interlocking (ZSI) function should be used for larger networks and / or protection settings that are difficult to determine.

### 11.2.3 Use in the Distribution Circuit

The distribution circuit receives power from the higher level (supply circuit) and feeds it to the next distribution level (final circuit). Depending on the country, local practices, etc., circuit-breakers and fuses can be used for system protection; in principle, all protection devices described in this chapter. The specifications for the circuit dimensioning must be fulfilled. If full selectivity is required, air circuit-breakers (ACB) are advantageous. However for cost reasons, the ACB is only frequently used in the distribution circuit as of a rated current of 630 A or 800 A. Since the ACB is not a current-limiting device, it significantly differs from all of the other protection devices such as moulded-case circuit-breakers (MCCB), miniature circuit-breakers (MCB), and fuses. [Tab. 11/2](#) shows the most important differences and limitations of the respective protection devices.

### 11.2.4 Use in the Final Circuit

The final circuit receives power from the distribution circuit and supplies it to the consumer (for example a motor, lamp, non-stationary load through a power outlet, etc.). The protection device must satisfy the requirements of the consumer to be protected by it.

*Note: All protection settings, comparison of characteristic curves, etc. always start with the load. This means that no protection devices are required with adjustable time grading in the final circuit.*

		ACB Air circuit- breaker	MCCB Moulded-case circuit-breaker	Fuse-switch- disconnecter	Switch- disconnectors with fuses	MCB Miniature circuit-breaker	Reference value, specifications
Standards	IEC	Yes	Yes	Yes	Yes	Yes	Region
Application	System protection	Yes	Yes	Yes	Yes	Yes	Power supply system
Mounting	Fixed mounting	Yes	Yes	Yes	Yes	Yes	Availability
	Plug-in	–	Max. 800 A	–	Partly	–	
	Withdrawable unit	Yes	Yes	–	–	–	
Nominal current	$I_n$	Max. 6,300 A	Max. 1,600 A	Max. 630 A	Max. 630 A	Max. 125 A	Operating current $I_B$
Short-circuit breaking capacity	$I_{cu}$	Max. 150 kA	Max. 150 kA	Max. 120 kA	Max. 120 kA	Max. 25 kA	Max. short-circuit current $I_{kmax}$
No. of phases	3-phase	Yes	Yes	Yes	Yes	Yes	Power supply system
	4-phase	Yes	Yes	–	Partly	–	
Tripping characteristics	ETU <sup>1)</sup>	Yes	Yes	–	–	–	Power supply system
	TMTU <sup>2)</sup>	–	Partly	Yes	Yes	Yes	
Tripping function	LI	Yes	Yes	Yes	Yes	Yes	Power supply system
	LSI	Yes	Yes	–	–	–	
	N	Yes	Yes	–	–	Yes (2-/4-phase)	
	G	Yes	Yes	–	–	–	
Characteristics	Fixed	–	Yes	Yes	Yes	Yes	Power supply system
	Adjustable	Yes	Yes	–	–	–	
	Optional	Yes	Yes	–	–	–	
Communication (data transmission)	High	Yes	–	–	–	–	Customer specification
	Medium	Yes	Yes	–	–	–	
	Low	Yes	Yes	Yes	Yes	Yes	
Activation	Local	Yes	Yes	Yes	Yes	Yes	Customer specification
	Remote (motor)	Yes	Yes	–	Partly	–	
Derating	Full rated current up to	60 °C	50 °C	30 °C	30 °C	30 °C	Switchgear
System synchronisation		Yes	Max. 800 A	–	–	–	Power supply system
Selectivity		Yes	Conditional (dependent on network topology and the short-circuit currents present)	Yes (limited use owing to limited rated current and convenience)	Yes (limited use owing to limited rated current and convenience)	Conditional (dependent on network topology and the short-circuit currents present; in addition the rated current is limited)	Customer specification, power supply system

<sup>1)</sup> ETU: electronic trip unit <sup>2)</sup> TMTU: thermo-magnetic trip unit

Tab. 11/2: Selection criteria for switching and protection devices

[back to page 238](#)

## 11.3 Residual Current and Arc-fault Detection Devices

Protection systems for the electrical installations of building must also provide for fault and fire protection to ensure personal safety and system protection. Protection against electric shock under single-fault conditions is referred to as fault protection (previously: protection against indirect contact). To protect a person who is in contact with a live part which is not live under normal operating conditions, it is required that the power supply is disconnected automatically if a hazard arises owing to a fault and as a result of the magnitude and duration of the contact voltage present.

Residual current devices (RCDs) detect a leakage current which is caused by insulation faults or inadvertent contact with live parts. Thus they contribute to personal safety and fire protection. A summation current transformer is used to compare the currents in the active conductor or the difference between the phase current and the neutral conductor with a release threshold.

The majority of electrical accidents are caused by faults in the final circuit. The reasons are both a high stress on the cabling to the consumer equipment (missing strain relief, cable bending radii, etc.) and improper handling and lack of maintenance. The use of residual current devices and the recently developed arc-fault detection units by Siemens considerably increase personal as well as building safety.

### 11.3.1 Residual Current Devices

Protection measures against electric shock are described in IEC 60364-4-41 (VDE 0100-410). Residual current devices (RCD) can be used in all power supply systems (TN, TT, IT system) of an alternating current or three-phase network. In such networks, residual current devices are superior to other permitted protection devices in their protection effect, since they provide additional protection (protection against direct contact) besides mere fault protection (protection against indirect contact) if they are used with a characteristic of  $I_{\Delta n} \leq 30 \text{ mA}$ , and they also effectively prevent electrically ignited fires caused by earth-fault currents through  $I_{\Delta n} \leq 300 \text{ mA}$ .

Fig. 11/3 demonstrates the physiological reactions of the human body to current flow subsumed in amperage levels according to IEC/TS 60479-1 (VDE V 0140-479-1). Dangerous are current-time values in the range of level 4, as they can cause ventricular fibrillation which may be lethal for the affected person. The tripping range of the RCD with a rated fault current of 30 mA is marked.

In the IT system, a disconnection upon the first fault is not required. But precautions have to be made that prevent the

risk of hazardous physiological effects on the human body. In dependency of the different requirements of IEC 60364 4-41 (VDE 0100-410) for TN and TT systems, appropriate protection devices must be selected (see Tab. 11/3).

In everyday practice, residual current protection devices of type A (alternating current and pulsating direct currents) are mainly used. Owing to the increased use of equipment accommodating power semiconductors (for example computer power supply units, chargers, frequency converters), this type, however, does not provide sufficient protection. Depending on requirements, a type as listed in Tab. 11/4 must be selected, since otherwise there is the risk that the fault is not disconnected, or at least not within the specified thresholds. Besides type B, a type F (Fig. 11/4) is also supplied by Siemens, which reliably detects and disconnects additional mixed frequencies, as they are common in frequency converters in the single-phase AC network. A type classification according to the different forms of fault currents is presented in Tab. 11/5.

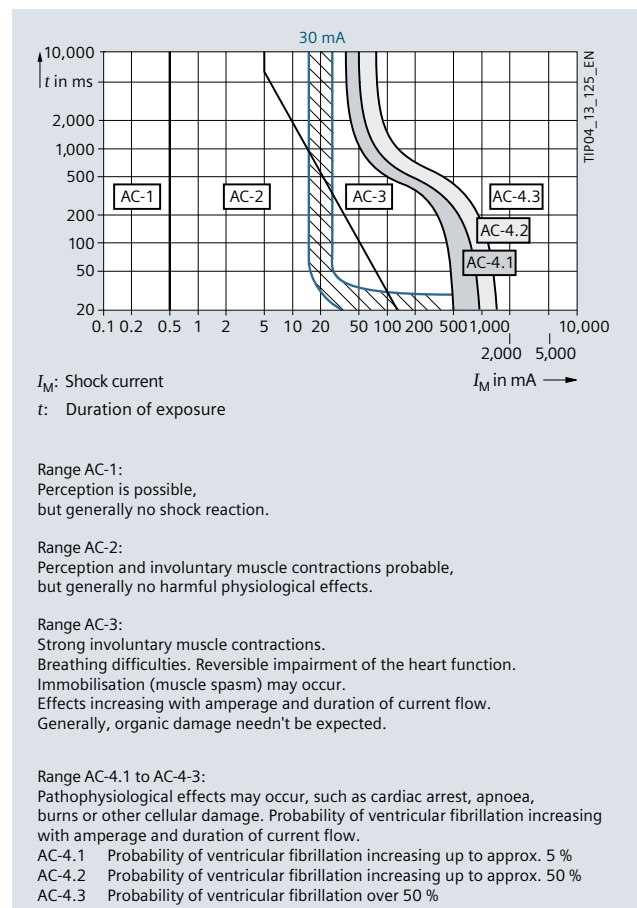

Fig. 11/3: Scope of effects of alternating current (50/60 Hz) on the human body

	TN system	TT system
Max. permissible disconnect time acc. to IEC 60364-4-41 (VDE 0100-410)	0.4 s (120 V < $U_0 \leq 230$ V)	0.2 s (120 V < $U_0 \leq 230$ V)
Disconnect currents $I_a$ of overcurrent protection devices for ensuring the required disconnect time $t_a$	$I_a \leq U_0 / Z_s$	
	Protection device	$I_a$ $t_a^{1)}$
	MCB type B	$\geq 5 I_n$ <0.1 s
	MCB type C	$\geq 10 I_n$ <0.1 s
	Fuse gG	approx. $\geq 14 I_n$ <0.4 s
Disconnect conditions of residual current devices for ensuring the required disconnect time $t_a$	$I_a \leq U_0 / Z_s$	
	Fault currents $I_F$ are substantially higher than 5 $I_{\Delta n}$ in the TN system	
	$I_{\Delta n} \leq 50 \text{ V} / R_A$	
	With $U_0 = 230$ V, the following applies to the tripping current $I_a$ in case of fault: $I_a = (230 \text{ V} / 50 \text{ V}) \cdot I_{\Delta n} = 4.6 I_{\Delta n}$	
	Type	$I_a$ $t_a^{1)}$
RCD general	$> 5 I_{\Delta n}$ $\leq 0.04$ s	
RCD selective	$> 5 I_{\Delta n}$ $\leq 0.15$ s	
	Type	$I_a$ $t_a^{1)}$
	RCD general	$> 2 I_{\Delta n}$ $\leq 0.15$ s
	RCD selective	$> 2 I_{\Delta n}$ $\leq 0.2$ s

1) The values for  $t_a$  refer to the specifications in the relevant product standards.  
 $I_{\Delta n}$  Rated residual current of residual current device in A  
 $R_A$  Sum of resistances of the earth electrode and the protection conductor of the exposed conductive parts  
 $U_0$  Nominal AC voltage of phase to earth  
 $Z_s$  Fault loop impedance

Tab. 11/3: Protection device selection in the TN and TT system with rated voltages of 230/400 V AC

















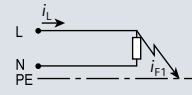

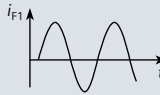
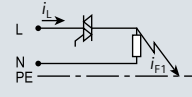
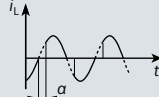

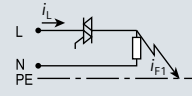

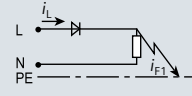
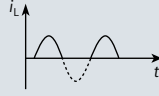
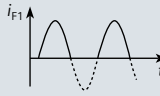
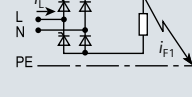
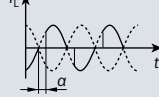
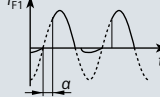
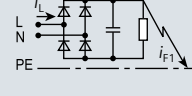
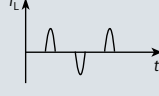
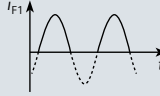
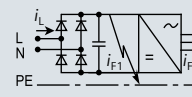
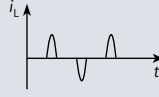
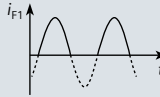
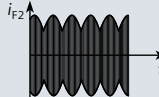
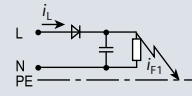
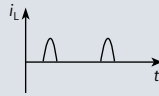
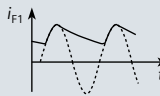
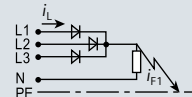
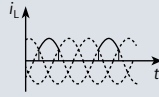
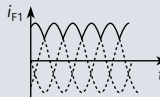
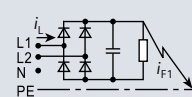

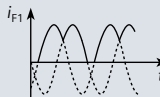
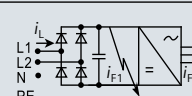
[back to page 240](#)

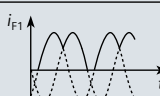
Current type	Current form	Type					Type	Tripping current
		AC	A	F	B	B+		
Alternating current		■	■	■	■	■	0.5 ... 1.0 $I_{\Delta n}$	
Pulsating direct fault currents (positive or negative half-waves)			■	■	■	■	0.35 ... 1.4 $I_{\Delta n}$	
Cut half-wave currents			■	■	■	■	Phase angle 90°: 0.25 ... 1.4 $I_{\Delta n}$	
			■	■	■	■	Phase angle 135°: 0.11 ... 1.4 $I_{\Delta n}$	
Half-wave current overlaid with smooth direct current			■	■	■	■	max. 1.4 $I_{\Delta n}$ + DC	
Fault current resulting from mixed frequency				■	■	■	0.5 ... 1.4 $I_{\Delta n}$	
Smooth direct current					■	■	0.5 ... 2.0 $I_{\Delta n}$	

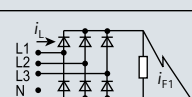
TIPO4\_13\_126\_EN

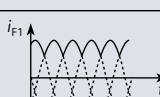
Tab. 11/4: Types of residual current devices and their tripping ranges

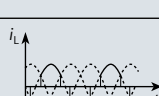
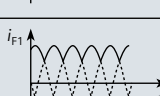
[back to page 240](#)

Suitable RCD type	Circuit	Load current	Fault current
<div style="display: flex; justify-content: space-around;"> <div style="text-align: center;"> <b>B</b>      <b>B+</b> </div> <div style="text-align: center;"> <b>F</b>     </div> <div style="text-align: center;"> <b>A</b>   </div> <div style="text-align: center;"> <b>AC</b>   </div> </div>			
			
			
			
			
			
			 
			
			
			
			 
			
			 

TIP04\_13\_127\_EN

Tab. 11/5: Residual current device types and possible forms of fault currents

[back to page 240](#)

Residual current devices are distinguished according to their different designs (see Fig. 11/5):

- **RCD** is the generic term for all kinds of residual current devices
- **RCCB** refers to devices without integrated overcurrent protection which are known in Germany as residual current operated circuit-breakers
- **An RCBO** is a device which combines protection against fault currents with an integrated overcurrent protector for overload and short-circuit protection in one device, referred to as residual current operated circuit-breaker with overcurrent protector. Another variant in this device group is the residual current unit (RCU). These residual current units allow the customer to mount the miniature circuit-breakers versions (characteristic, rated current, switching capacity) desired for the specific application. After assembly these devices provide the same functions as RCBOs. The RCU does not have contacts of its own for fault current detection, but trips the miniature circuit-breaker in the event of a fault by being coupled to it. The MCB opens the contacts and interrupts the circuit. In terms of the tripping conditions for alternating and pulsating fault currents RCCBs and RCBOs (type A) are only permitted for the protection measure of disconnection



Fig. 11/4: Residual current operated circuit-breaker type F

[back to page 240](#)

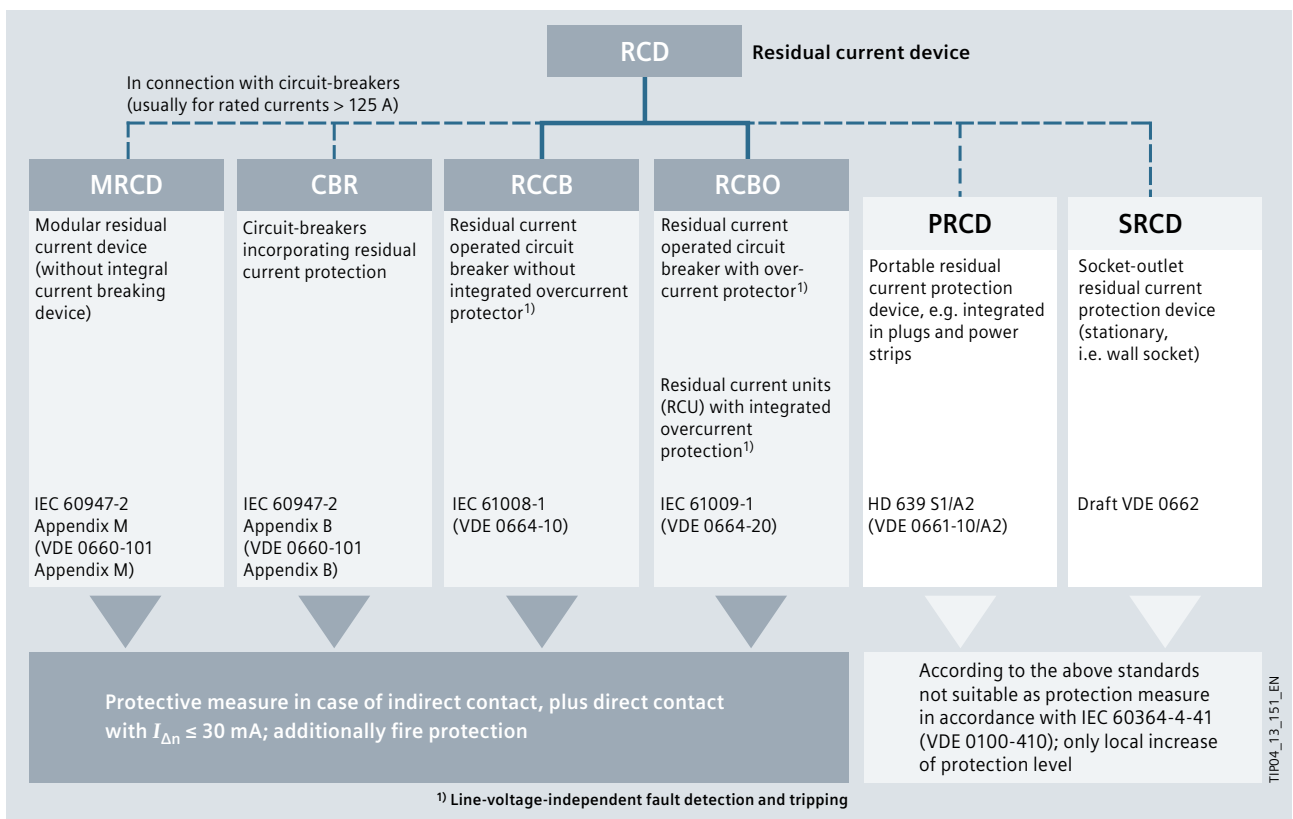

Fig. 11/5: Classification of residual current devices (RCDs)

1

as line-voltage-independent versions in most European countries

2

- **CBRs** are circuit-breakers with fault current protection in accordance with IEC 60947-2 (VDE 0660-101) Appendix B. Here, the residual current detection unit is fixed-mounted to a circuit-breaker, thus ensuring fault current protection

3

- **MRCDs** are devices in modular design, which means fault current detection (using current transformers), evaluation, and tripping (through circuit-breakers) is performed in separate modules (in accordance with IEC 60947-2, VDE 0660-101 Appendix M)

4

5

CBRs and MRCDs are intended for applications with high rated currents (> 125 A) in particular.

6

- **PRCDs** in accordance with HD 639 S1/A2 (VDE 0661-10/A2) are portable residual current devices which are integrated in plugs or in power strips for example

7

- **SRCDs** in accordance with VDE 0662 (draft) are stationary residual current devices integrated in a socket-outlet (wall socket) or form a unit with a socket-outlet

8

PRCDs and SRCDs can be used to increase the protection level in applications where the required protection measure is ensured by other means. They are not permitted to implement a protection measure of disconnection.

9

### 11.3.2 Arc-Fault Detection Units

Over a hundred thousand fires are detected every year in Europe. The shocking outcome: many casualties and injured and material damage amounting to billions of euros. More than one fourth of these fires can be attributed to arc faults – frequently caused by defects in the electrical installation. An arc fault can, among other things, be caused by damaged cable insulation, squeezed leads, kinked plugs or loose contact points in the electrical installation. The result is heavy heating which may eventually result in a cable fire and finally a fire of the whole building.

10

11

12

13

14

15

16

17

Glowing connections or arc faults cannot be detected by conventional protection devices, as they have little influence on the load current. In order to detect such faults, the arc-fault detection device permanently measures the high-frequency noise (Fig. 11/6) of voltage and current as well as their intensity, duration, and the gaps in between. Integrated filters with intelligent software analyse these signals and initiate the disconnection of the connected circuit within fractions of a second in case of abnormal conditions.

Harmless sources of interference, such as drills or hoovers which are operated at the moment can be distinguished from dangerous arcs by the arc-fault detection unit. As a

complement to residual current operated circuit-breakers and miniature circuit-breakers, the 5SM6 arc-fault detection unit (Fig. 11/7) increases personal safety, protects material assets, and closes a gap in the protection against electrically ignited fires. The general requirements for arc-fault detection devices (AFDD) are specified in IEC 62606 (VDE 0665-10).

The arc-fault detection unit responds to the following faults:

- Serial fault with arc fault
- Parallel fault with arc fault
- Overvoltage (however self-protection in the event of a voltage higher than 275 V)

If such a fault is detected, the arc-fault detection unit trips a mounted miniature circuit-breaker, respectively a combined residual current protection device plus miniature circuit-breaker. The status LED of the arc-fault detection unit indicates the detected fault. The fault display can be reset by switching the device on-off-on.

In IEC 60364-4-42 the application of AFDD's is recommended in:

- Premises with sleeping accommodation
- Locations with risk of fire (due to the nature of processed or stored materials)
- Locations with combustible constructional material
- Fire propagating structures
- Locations with endangering of irreplaceable goods.

According to the German implementation VDE 0100-420 of the international standard IEC 60364-4-42, the usage of AFDD must be provided for such applications.

More information: [siemens.com/sentron](http://siemens.com/sentron)



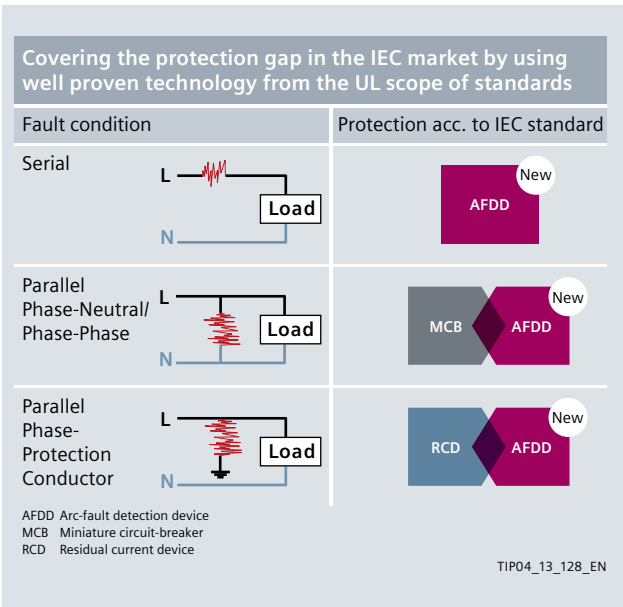

Fig. 11/6: Protection concept with arc-fault detection device [back to page 244](#)



Fig. 11/7: 5SM6 arc-fault detection unit [back to page 244](#)

Con-  
tents

Intro-  
duction

1

2

3

4

5

6

7

8

9

10

**11**

12

13

14

15

16

17



# Chapter 12

## Starting, Switching, and Protecting Motors

12.1	Protecting Electric Motors	248
12.2	Switching Electric Motors	249
12.3	Comparison of Connections for Motor Start-up	256
12.4	Safety of Machines	258

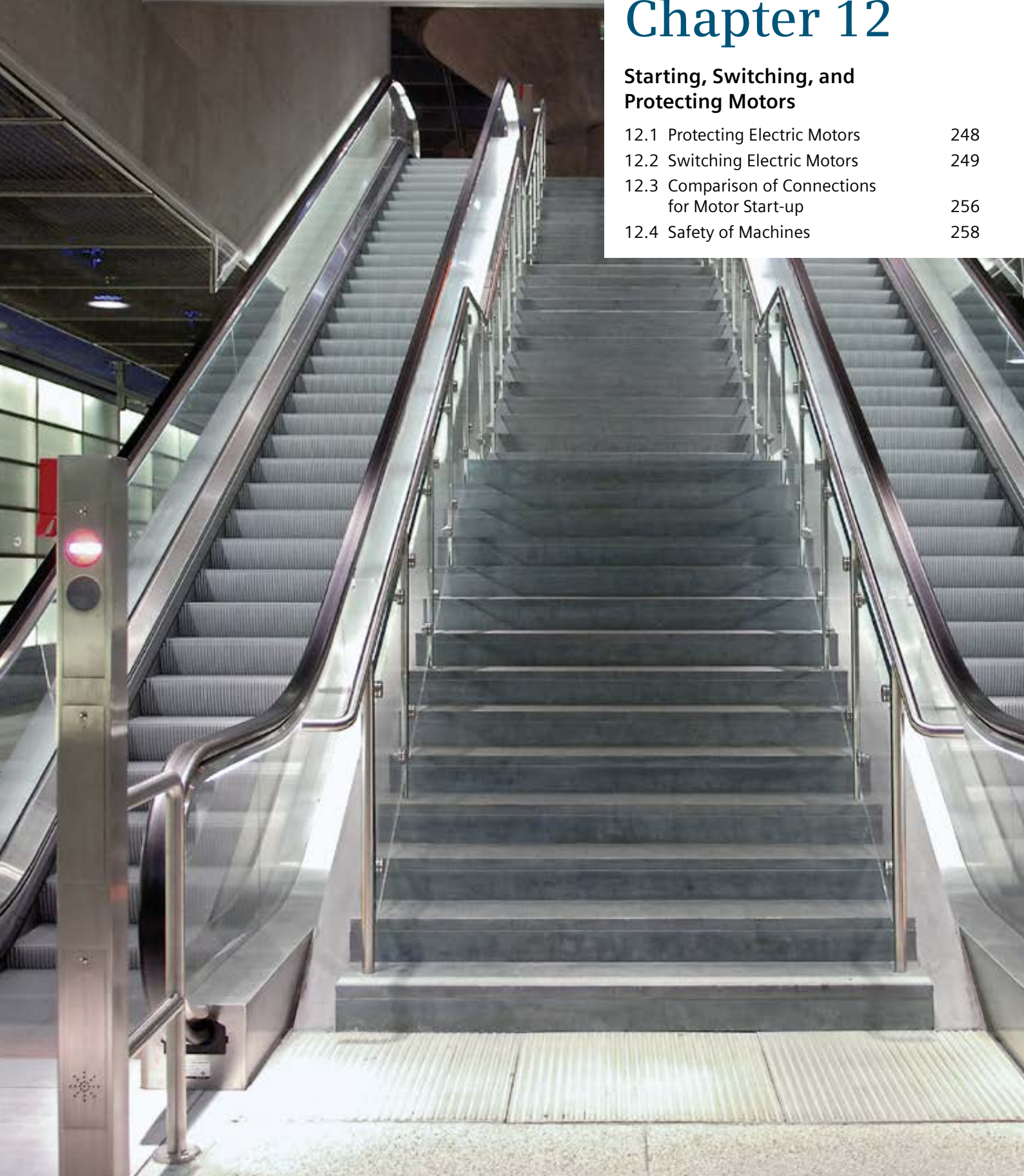

# 12 Starting, Switching, and Protecting Motors

When planning and selecting the control and protection of motors, the relevant standards and regulations must be taken into account. Essentially, these are the standards IEC 60947-4-1 (VDE 0660-102) and IEC 60947-4-2 (VDE 0660-117) as well as the IEC 60364 (VDE 0100) series of standards and the EMC-relevant IEC 61000 (VDE 0839) series of standards. The protection devices must ensure the protection of the cable and the motor in a motor feeder. This can be achieved with separate devices or through a combination with both functions (see chapter 7).

## 12.1 Protecting Electric Motors

Motor protection can be performed with

- Overcurrent releases (motor protection according to IEC 60947-4-1; VDE 0660-102)
- Temperature sensors (always in the motor winding)
- Electronic motor protection devices (SIMOCODE)

When configuring the motor protection, a combination of central and distributed components makes sense. A central configuration has benefits when the motors to be switched are arranged close to each other. When wiring protection devices and motors, devices with standardised connection methods as described in ISO 23570-2 and -3, are a maintenance-friendly solution. The individual components can be quickly installed and replaced. Standardised interfaces significantly reduce the number of faults during installation. The downtimes are reduced during operation.

The motor output is mainly influenced by the current, and therefore by the maximum winding temperature. The main task of the motor protection is therefore to prevent heating above the temperature limit in the stator and rotor windings. When rating the motor protection, a distinction must be made between motors with thermally critical rotors and motors with thermally critical stators.

- Thermally critical rotors:  
the temperature limit is reached in the rotor first
- Thermally critical stators:  
the temperature limit is reached in the stator first

*Note: Rule of thumb – small and medium-sized motors usually have thermally critical stators. The larger the motor and the higher the speed, the higher the starting current and the more thermally critical the rotor.*

The trip classes of the motor protection (IEC 60947-4-1; VDE 0660-102) are based on the tripping times at 7.2 times the current setting  $I_e$  in the cold state. The tripping times are:

- CLASS 5 between 0.5 and 5 s
- CLASS 10A between 2 and 10 s
- CLASS 10 between 4 and 10 s
- CLASS 20 between 6 and 20 s
- CLASS 30 between 9 and 30 s

In practice, mostly devices of the CLASS 5, 10, and 10A trip classes are used for standard applications. They are also called the classes for normal start-up. The combinations for CLASS 20 and CLASS 30 are available for applications in which a higher starting current is required over a longer time. Standard devices of CLASS 5 and CLASS 10 would result in unwanted tripping at start-up here. CLASS 20 is called heavy starting and CLASS 30 very heavy starting. Examples of such applications are large fan motors.

In addition to the overload protection devices, the contactors and the short-circuit fuses must be dimensioned accordingly. The combinations according to CLASS 5 and CLASS 10 are therefore usually somewhat more economic. In the majority of cases, CLASS 20 and CLASS 30 are only used when they are really required by the application.

There are different types of protection:

- Fuse-protected with fuses:  
Fuse – contactor – overload relay
- Circuit-breaker-protected with circuit-breaker for the starter protection:  
Circuit-breaker – contactor – overload relay
- Circuit-breaker-protected with circuit-breaker for the motor protection:  
Circuit-breaker – contactor

With regard to the switching devices, there are electronic, current-dependent protection devices; also as a combination of fuses and contactor, circuit-breaker with contactor as well as part of circuit-breakers. There are also temperature-dependent protection devices, such as thermistor motor protection.

## 12.2 Switching Electric Motors

The start-up and operating behaviour of the three-phase induction motor is determined by two physical variables, the torque and the consumed current. To switch electric motors, there are electromechanical solutions (direct start, star-delta) and electronic solutions (soft starter, frequency converter, semiconductor switching devices).

Ten operating modes according to IEC 60034-1 (VDE 0530-1) determine the main uses of the respective electric motors (see Tab. 12/1). They can be divided into three groups:

- Continuous duty S1 and duty with separate constant loads S10
- S2, S3, S6 are operating modes that permit an increase in output compared to continuous duty S1; the result is that the motor is not overloaded
- S4, S5, S7, S8, S9 are operating modes that require a decrease in output compared to continuous duty S1; the result is that the motor will probably be overloaded and therefore, a more powerful motor must be configured

<p><b>S1 – continuous duty</b></p> <ul style="list-style-type: none"> <li>• Constant load state with rated power</li> <li>• Thermal steady state is reached</li> </ul>	
<p><b>S2 – short-time duty</b></p> <ul style="list-style-type: none"> <li>• Constant load state</li> <li>• Thermal steady state is not reached</li> <li>• Pause long enough for the system cooling until <math>(\Theta - \Theta_0) &lt; 2K</math></li> <li>• Temperature limit of the components is not reached <math>\rightarrow t_B</math>, is selected accordingly for only a short time</li> <li>• (Load current <math>\uparrow \geq</math> load time <math>\downarrow</math>)</li> </ul>	
<p><b>S3 – intermittent periodic duty</b></p> <ul style="list-style-type: none"> <li>• Constant load state</li> <li>• Sequence of identical switching cycles (load and pause times can vary)</li> <li>• Thermal steady state is not reached</li> <li>• Thermal balance of the plant components is not achieved during heating or cooling</li> </ul>	
<p><b>S4 – like S3 with an effect on the start-up process</b></p> <ul style="list-style-type: none"> <li>• Sequence of identical switching cycles with long start-up time <math>t_A</math>, constant load and pause</li> </ul>	

$P$  load  $P_v$  electrical losses  $\Theta$  temperature  $t$  time  $T_c$  cycle time

Tab. 12/1: Operating modes according to IEC 60034-1 (VDE0530-1)

<p><b>S5 – like S4 with electrical braking</b></p> <ul style="list-style-type: none"> <li>• Sequence of identical switching cycles with long start-up time <math>t_A</math>, constant load and pause</li> <li>• Operating cycle includes electrical braking</li> </ul>	
<p><b>S6 – continuous periodic duty</b></p> <ul style="list-style-type: none"> <li>• Sequence of identical switching cycles</li> <li>• Constant load</li> <li>• Idle time <math>t_L</math></li> <li>• No pause</li> <li>• Thermal steady state is not reached</li> </ul>	
<p><b>S7 – like S6 with electrical braking</b></p> <ul style="list-style-type: none"> <li>• Sequence of identical switching cycles</li> <li>• Start-up time <math>t_A</math> and electrical braking <math>t_{Br}</math></li> <li>• No pause</li> </ul>	
<p><b>S8 – like S6 with load/speed change</b></p> <ul style="list-style-type: none"> <li>• Constant load state</li> <li>• Sequence of identical switching cycles (load and pause times can vary)</li> <li>• Thermal steady state is not reached</li> <li>• Thermal balance of the plant components is not achieved during heating or cooling</li> </ul>	
<p><b>S9 – duty with non-periodic load/speed change</b></p> <ul style="list-style-type: none"> <li>• Non-periodic load/speed change in the permissible operating range</li> <li>• Frequent load peaks above the rated power</li> <li>• Suitably selected continuous load required as reference for the load cycle</li> <li>• Mixture of short-time duty, intermittent periodic duty and continuous duty</li> </ul>	
<p><b>S10 – duty with separate constant loads and speeds</b></p> <ul style="list-style-type: none"> <li>• Thermal load state is reached</li> <li>• Reference value for a constant load must have been specified</li> </ul>	

$P$  load  $P_v$  electrical losses  $\theta$  temperature  $t$  time  $T_c$  cycle time

## Direct and reversing starters

These devices are a cost-effective solution for switching motors. They ensure a short acceleration time and a high start-up torque.

There are two variants:

- Electromechanical switching devices (IEC 60947-4-1; VDE 0660-102)
- Electronic (semiconductor) switching devices (IEC 60947-4-2; VDE 0660-117)

With electromechanical switches, the operating mode (see Tab. 12/1) must be taken into account during the selection because loads vary dependent on the type and operating mode. If the ON time of the motor is short compared to the start-up time, there is a higher load and the switching device must be dimensioned larger. Since the service life depends on the number of switching cycles for electromechanical switching devices, it is recommended that electronic switching devices be used for a large number of switching cycles (constant switching frequency > 200 switching cycles per hour). Since the inrush currents are high for these devices (electromechanical as well as electronic switches) at the start-up of larger motors, star-delta start-ups are also used for three-phase motors. The motor is first operated in star connection during start-up and then switched to delta connection. The start-up current is limited to 1/3 compared to a direct switch-on. It is important that the motor has the required electric strength for the delta connection.

### Direct start with contactor

In contrast to the motor, rather than the total energy (heating) it is the inrush and the breaking currents that must be considered for the contactor. The different switching cycles for each utilisation category are usually specified in the catalogues. The dimensioning of the contactors in the main circuit or the utilisation category can be determined from IEC 60947-1 (VDE 0660-100). The associated device standards are also listed there.

*Note: With regard to the dimensioning in the control circuit, attention should be paid to the overvoltage damping when shutting down the contactor coils. Voltage peaks with large steep edge up to 4 kV for approximately 250 µs (shower discharges) occur particularly during shut-down. This may result in signal errors in the electronic control units or a defect, or a strong erosion of the contacts that switch the coil.*

Long control cables also influence the switching behaviour of contactors when switching on. If long control cables are required for the control circuits of contactors or relays,

malfunctions may occur during switching in certain circumstances. In this case, contactors may not make or break.

#### Switching on:

Because of the large voltage drop in long control cables, the control voltage applied at the contactor may fall below the threshold value required to switch on the contactor. This affects both DC- and AC-actuated contactors. The following countermeasures can be implemented here:

- Change the switching topology so that shorter control cables can be used
- Increase the cable cross section
- Increase the control voltage
- Use a contactor with less closing power for the solenoid

#### Switching off:

When switching off AC-actuated contactors, the contactor may no longer switch off when the control circuit is interrupted because of a control cable capacitance that is too large. The following countermeasures can be implemented here:

- Change the switching topology so that shorter control cables can be used
- Use DC-actuated contactors
- Reduce the control voltage
- Use a contactor with greater holding power for the solenoid
- Connect an ohmic resistance in parallel to increase the holding power (additional load unit)

### Star-delta start

The star-delta start-up is still used to switch on three-phase induction motors particularly in order to limit system perturbations through current surges that suddenly occur. In this connection method, the start-up current is reduced to a 1/3 of the current for the direct switch-on, which also results in a corresponding reduction of the start-up torque. Because of this reduction in torque during a star-delta start, usually only one start-up operation is possible with constantly low load torque (for example, when starting machine tools under no load). The motor overload protection must be effective in both the star and the delta connection.

*Note: Due to an unfavourable constellation of system frequency and rotor field, compensation processes may occur increasingly in the motor when switching from star to delta (rotor field induces a residual voltage), which results in higher current peaks than during the direct connection of the motor in standstill in star connection.*

In the worst case, this results in the following problems:

- Short-circuit devices trip
- The delta contactor is welded or is subject to high contact erosion
- The motor is subject to a high dynamic stress

Current peaks can be minimised through a preferred connection during the switchover.

*Tip: An optimised wiring of the delta contactor produces a favourable vector position of the residual voltage with regard to the line voltage and consequently the differential voltage is reduced.*

**Semiconductor connection**

Semiconductor switching devices are designed for high switching frequencies. They do not have any mechanical, moving parts and therefore have an almost endless service life. Further advantages are:

- Noiseless switching
- They are impervious to shock, strong vibrations, and electromagnetic fields
- They can be used in damp and polluted environments
- They switch without an arc fault and therefore have low interference emission

**Soft starter**

Another way to limit the start-up current is to use soft starters. The soft start-up has the following advantages compared to a load feeder / motor starter:

- Current peaks are cleared during start-up
- Smooth start-up
- Lower mechanical stressing for the load

The motor feeder between the soft starter and the motor must not contain any capacitive elements (e.g. no reactive power compensation unit). In order to avoid faults in the compensation unit and/or soft starter, neither static systems for reactive power compensation nor a dynamic power factor correction (PFC) may be operated during the starting and stopping of the soft starter.

When selecting a soft starter, it is important that the application and the start-up time of the motor are considered closely. Long start-up times mean a thermal load on the soft starter. The software "STS" (Simulation Tool for Soft Starters) can be used to simulate and select Siemens soft starters taking into account various parameters such as the power system conditions, motor data, load data, and special application requirements.

Tab. 12/2 lists typical settings and device dimensions; they are for information purposes only and are not binding. The settings are application-dependent and must be optimised during commissioning. The load torque (the curve could be constant, linear, square or inversely proportional like for mills) and the motor torque curve influences selection and parameterisation of the soft starter. These tasks are simplified by the software "STS".

For better control, soft starters such as the Siemens SIRIUS 3RW devices have the patented "Polarity Balancing" activation method. This eliminates DC components produced by the phase angle and the superimposition of the phase currents during a 2-phase activation in the start-up procedure. These DC components would cause more noise on the motor. It enables a motor start-up with a uniform speed, torque, and current rise. The acoustic quality of the start-up therefore nearly reaches the same level as a 3-phase controlled start-up procedure. This is made possible through the continuous, dynamic adjustment or balancing of current half-waves with different polarity during the motor start-up. "Polarity balancing" however does not prevent the entire unbalance. But DC components in phase currents which can cause audible noise and additional heating are eliminated.



**Normal starting CLASS 10 (up to 20 s with 350%  $I_{nMotor}$ )**  
 The performance of the soft starter can be selected the same size as the performance of the motor

Application	Conveyor belt	Roller conveyor	Compressor	Small ventilator	Pump	Hydraulic pump
Start-up parameters						
• Voltage ramp and current limiting						
– Starting voltage	% 70	60	50	30	30	30
– Start-up time	s 10	10	10	10	10	10
– Current limiting value	Deactivated	Deactivated	$4 \cdot I_M$	$4 \cdot I_M$	Deactivated	Deactivated
• Torque ramp						
– Starting torque	% 60	50	40	20	10	10
– Final torque	% 150	150	150	150	150	150
– Start-up time	s 10	10	10	10	10	10
• Break-away pulse	Deactivated (0 ms)	Deactivated (0 ms)	Deactivated (0 ms)	Deactivated (0 ms)	Deactivated (0 ms)	Deactivated (0 ms)
Stopping method	Soft stopping	Soft stopping	Free stopping	Free stopping	Free stopping	Free stopping

**Heavy starting CLASS 20 (up to 40 s with 350%  $I_{nMotor}$ )**  
 The soft starter should be selected one performance class higher than the motor

Application	Agitator	Centrifuge	Milling machine
Start-up parameters			
• Voltage ramp and current limiting			
– Start voltage	% 30	30	30
– Start-up time	s 30	30	10
– Current limiting value	$4 \cdot I_M$	$4 \cdot I_M$	$4 \cdot I_M$
• Torque ramp			
– Starting torque	% 30	30	30
– Final torque	% 150	150	150
– Start-up time	s 30	30	30
• Break-away pulse	Deactivated (0 ms)	Deactivated (0 ms)	Deactivated (0 ms)
Stopping method	Free stopping	Free stopping	Free stopping of DC braking

**Heavy starting CLASS 30 (up to 60 s with 350%  $I_{nMotor}$ )**  
 The soft starter should be selected two performance classes higher than the motor

Application	Large ventilator	Mill	Crusher	Circular saw / belt saw
Start-up parameters				
• Voltage ramp and current limiting				
– Start voltage	% 30	50	50	30
– Start-up time	s 60	60	60	60
– Current limiting value	$4 \cdot I_M$	$4 \cdot I_M$	$4 \cdot I_M$	$4 \cdot I_M$
• Torque ramp				
– Starting torque	% 20	50	50	20
– Final torque	% 150	150	150	150
– Start-up time	s 60	60	60	60
• Break-away pulse	Deactivated (0 ms)	80%, 300 ms	80%, 300 ms	Deactivated (0 ms)
Stopping method	Free stopping	Free stopping	Free stopping	Free stopping

Tab. 12/2: Examples of starting methods and settings for different applications

[back to page 252](#)

As the soft starter has a reduced starting torque, it is not suitable for all applications. The starting torque of the load must be less than or at the most equal to the starting torque of the motor. Typical applications are:

- Conveyor belts, transport systems:
  - Jerk-free starting
  - Jerk-free braking
- Rotary pumps, piston pumps
  - Avoidance of pressure surges
  - Extension of the service life of the pipe system
- Agitators and mixers:
  - Reduction of the starting current
- Large fans:
  - Protection of the gearbox and the V-belts

For this reason, different starting and stopping methods must be selected for the soft starter (see [Tab. 12/3](#) and [Tab. 12/4](#)).

Semiconductor fuses should be used as upstream protection devices to fulfill requirements of coordination type 2 according IEC 60947-4-2 (VDE 0660-117). With an increased switching frequency, the technical data of the manufacturer must be considered in any case. The average switching frequency is approximately 20 switching cycles per hour. During planning, the special regulations of the device manufacturer must be observed. These refer to the installation instructions and the selection of the switching and protection devices.

### Frequency converter

Frequency converters are used to adapt the speed in order to protect the mechanical system or reduce current peaks, as with the soft starter. Frequency converters are better than soft starters for dynamic processes. The speed of the connected motor can be changed continuously, and without almost any losses, by varying the voltage and the frequency. A motor can also be operated above the rated speed with a frequency converter, without the torque dropping off. A further advantage of frequency converters is the power feedback to the supply system.

*Note: Frequency converters are also available for 1- and 2-phase alternating current motors.*

Particularities of frequency converters are system perturbations and the effect on the EMC. As described in chapter 5, converters produce harmonic currents and voltages. As the other equipment in the supply system is designed for sinusoidal voltages, a distortion of the voltage can have negative effects or even destroy the equipment and electrical utilities.

Because of the increasing use of variable-speed drives, the assessment of system perturbations is also increasingly important. Not only the operators of supply networks, but also the operators of variable-speed drives are demanding more information from the manufacturers about the response of the drives to harmonic effects so that they can already check during the planning and configuration phases, whether the limit values of the standards will be adhered to. Line reactors or active filters must be provided to limit the system perturbations. Line reactors are generally required for:

- Networks with high short-circuit power (small impedance)
- Several converters on a common network connection point
- Converters in parallel operation
- Converters with line filters for RF interference suppression

Frequency converters with AFE feed-in / feedback unit (AFE = active front end, as available, for example, with SIMOVERT and DYNAVERT converters from Siemens) produce almost no system perturbations. They are an ideal solution for electrical utility companies and operators with high supply system demands. Four-quadrant operation (drives and regenerative braking in both directions of rotation) is possible with AFE. With the active input converter, not only a power factor of  $\cos \varphi = 1$  can be implemented, but the reactive power of other loads in the network can also be compensated as part of the power reserves. If the AFE is equipped with an input filter, operation on the supply system is possible with almost no harmonics.

According to the definition of the German EMC regulation (EMCR from 2008 based on the EMC Directive 2004 / 108 / EC) the electromagnetic compatibility of a device describes the "ability of equipment to function satisfactorily in its electromagnetic environment without introducing intolerable electromagnetic disturbances to other equipment in that environment". In order to comply with the relevant EMC regulations, the devices must have a sufficiently high interference immunity and the interference emission must be limited to acceptable values.

The IEC 61800-3 (VDE 0160-103) standard "Adjustable speed electrical power drive systems – Part 3: EMC requirements and specific test methods" defines the EMC requirements for variable-speed electric drives. A variable-speed electric drive system (PDS, power drive system) as defined in this standard comprises a drive converter and the electric motor including the connection cables. The driven machine is not part of the drive system.

Starting method	Meaning
Direct	If the "Direct" starting method is set, the voltage at the motor is increased to nearly the line voltage when the start command is issued. This corresponds approximately to the starting behaviour with a contactor.
Voltage ramp	The terminal voltage of the motor is increased within a settable start-up time from a parametrisable starting voltage to the line voltage.
Torque control	With the torque control, the torque generated in the motor is increased linearly from a parametrisable starting torque to parametrisable final torque within a settable torque starting time.
Voltage ramp + current limiting	In combination with the "Voltage ramp" starting method, the starter constantly measures the phase current during the current limiting via an integrated current transformer. A current limiting value ( $I_b$ ) can be set on the soft starter during the motor start-up. When this value is reached, the soft starter regulates the motor voltage so that the current does not exceed the set value. The current limiting is superimposed on the "Voltage ramp" starting method.
Torque ramp + current limiting	In combination with the "Torque control" starting method, the starter constantly measures the phase current during the current limiting via an integrated current transformer. A current limiting value can be set on the soft starter during the motor start-up. When this value is reached, the soft starter regulates the motor voltage so that the current does not exceed the set value. The current limiting is superimposed on the "Torque control" starting method.
Motor heating (supporting function)	If IP54 motors are used outdoors, condensation can form when the motor cools down (for example, over night or in winter). This can cause leakage currents or short circuits when the motor is switched on. A "pulsing" direct current is fed in to heat up the motor winding, which does not turn the motor.

Tab. 12/3: Starting methods for soft starters and their meaning

[back to page 254](#)

Stopping method	Meaning
Free stopping	In "Free stopping", the energy supply to the motor is interrupted when the ON command is cancelled on the soft starter. The motor runs down freely, only driven by the moment of inertia (rotating mass) of the rotor and the load.
Torque ramp	The free stopping is extended by the torque ramp. This function is used to prevent the load stopping suddenly. This is typical of applications with a small moment of inertia or high counter torque (for example, conveyor belts).
Pump stop	Pump stop is used to prevent water hammer when the pump is switched off. This reduces noise and the stressing of the pipes and any flaps contained therein.
DC braking	Free stopping is shortened by DC braking. DC braking should be used for applications with large moments of inertia. The moments of inertia of the load shouldn't be more than 5 times the moments of inertia of the motor: $J_{Load} \leq 5 \cdot J_{Motor}$
Dynamic DC braking / Compound braking	Free stopping is shortened by DC braking. Compound braking could be used for applications with small moments of inertia. The moments of inertia of the load shouldn't be more than the moments of inertia of the motor: $J_{Load} \leq J_{Motor}$

Tab. 12/4: Stopping methods for soft starters and their meaning

[back to page 254](#)

Line filters are used to reduce the radiation. These also limit the system perturbations. An electromagnetic-compatible installation is required so that the line filters can achieve their maximum effect. A shielded cable is required between the converter and the motor so that the parasitic currents can flow back to the converter along a low-inductance path. The motor cables should have a symmetric conductor structure.

The most important factors with regard to high-frequency leakage currents are:

- Size of the DC-link voltage
- DC-link voltage  $U_{ZK}$  of the converter
- Rate of voltage rise  $du/dt$  when switching

- Pulse frequency  $f_p$  of the inverter
- Converter output with or without motor reactor or motor filter
- Impedance  $Z_W$  (cable impedance) or capacitance  $C$  of the motor cable
- Inductance of the earthing system and all earthing and shield connections

The length of the motor cable must also be taken into account. Particularly with shielded cables, the cable capacitance increases with the cable length and causes additional current peaks. This current must also be supplied by the frequency converter which may result in overload and therefore the shutdown of the converter.

The following rules must be observed for an electromagnetic-compatible installation:

- Spatially separate sources of interference and susceptible equipment in the control cabinet (zone concept)

- Route signal leads and power cables separately; minimum clearance 20 cm

- If possible, lead the signal leads and power cables only from one side into the cabinet

- Lay the cables close to the earthed plates and not freely in the cabinet

- Always install RFI suppression filters close to the sources of interference

- Connect the shields of the digital signal leads at both ends and with good conductivity over a large area to earth (if required, several times)

- Connect the shields of the analogue signal leads with good equal potential bonding at both ends to earth. If low-frequency interference occurs, connect the shield at one end to the converter. The other end of the shield should be earthed via a capacitor

- Shields must not have any interruptions (through intermediate terminals, fuses, filters, contactors)

- Connect all variable-speed motors with shielded cables

- Connect all metal parts of the control cabinet of a large area with good conductivity

- Execute equipotential bonding with cables as short and thick as possible (10 mm<sup>2</sup>)

- Earth reserve conductors at both ends Avoid unnecessary cable lengths

- Twist the unshielded signal leads of the same circuit (phase and return conductors)

- Connect contactors, relays, etc. in the control cabinet with RC elements, diodes, and varistors

## 12.3 Comparison of Connections for Motor Start-up

The previously described starting connections result in different behaviours during motor start-up, which are illustrated graphically in Fig. 12/1 through a comparison of the voltage, current, and torque curves.

With a direct starter, the motors are stressed thermally and mechanically by the high current that is applied immediately. Voltage changes are also induced in the supply network. In order to limit these disturbances in the supply network, apparent power limit values are specified for the direct start in the technical supply conditions [14] of the German distribution system operators. The following are permitted for motors that start occasionally (twice a day):

- Alternating current motors with an apparent power of not more than 1.7 kVA or
- Three-phase motors with an apparent power of not more than 5.2 kVA or
- For higher apparent powers, motors with a starting current (r.m.s. value of current half periods) of not more than 60 A

With the star-delta starter in the star connection the voltage over the motor-winding is limited to  $1/\sqrt{3} = 0.58$  times the phase-to-phase voltage, which also reduces the starting current.

The soft starter increases the motor voltage within a specified start-up time. The starting voltage should be selected according to the break-away torque for the motor start-up. For example, the break-away pulse can be set for the SIRIUS 3RW44 soft starter. With the "root 3 connection" (Fig. 12/2) for soft starters, the rated current can be limited to  $1/\sqrt{3} = 0.58$  times the value of the rated motor current.

With the frequency converter, the drive can be ramped in a controlled manner with the rated current, because the start-up characteristic can be set. During operation, the control enables smooth changes in speed via variations in the frequency, whereby the drive can be operated with the rated torque even at low speeds. The speed control can be used to improve the efficiency during operation. The SIZER for Siemens configuration software supports the selection and dimensioning of the motor and frequency converter (further information on the Internet at [siemens.com/sizer](http://siemens.com/sizer)).

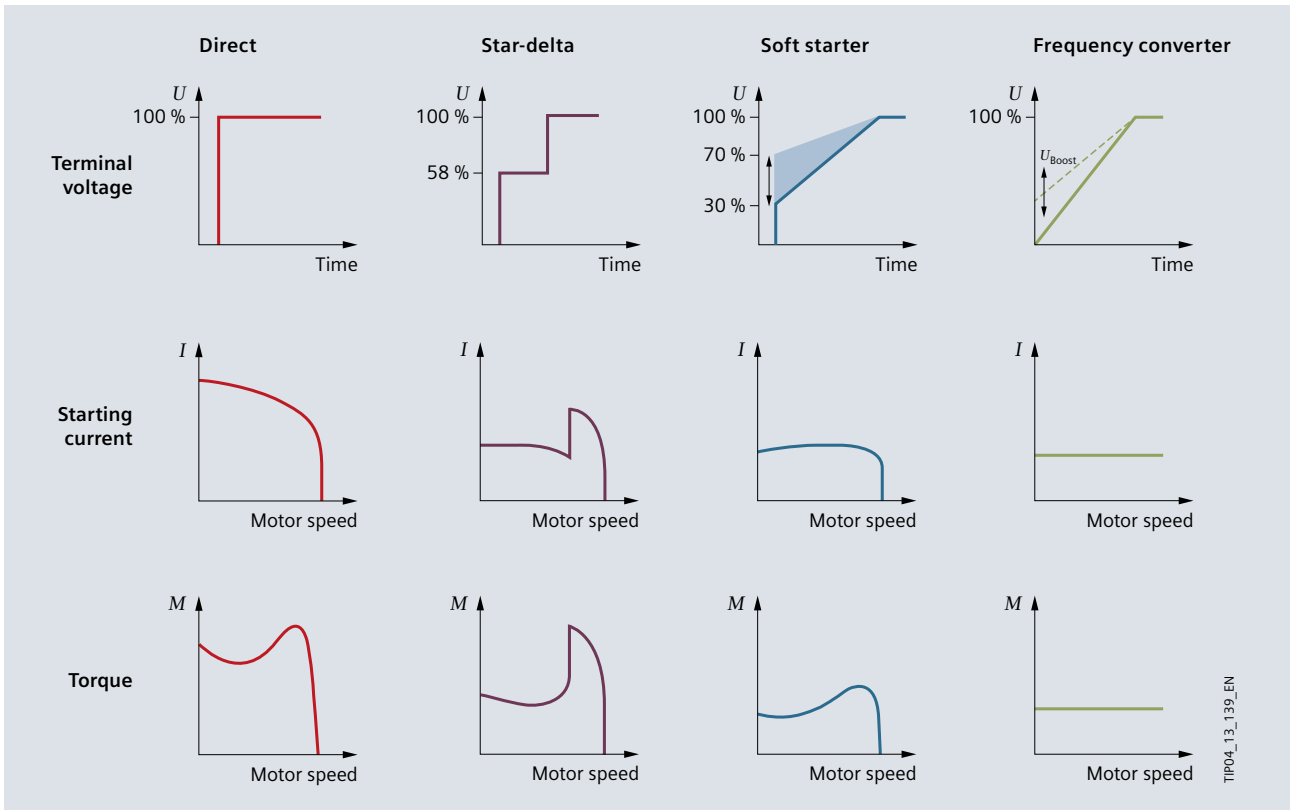

Fig. 12/1: Characteristic behaviour of the various connections during motor start-up

[back to page 256](#)

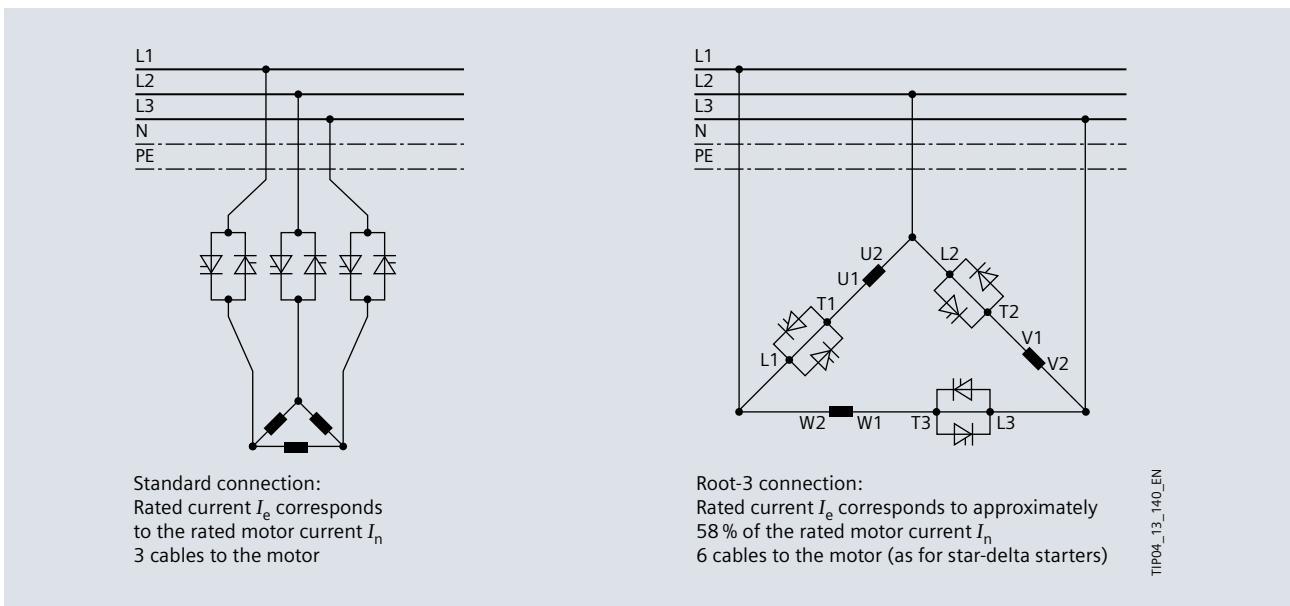

Fig. 12/2: Comparison of connections for soft starters between standard connection and root-3 connection

[back to page 256](#)

## 12.4 Safety of Machines

Manufacturers and operators of machines are legally obligated to guarantee the safety of personnel and the environment. In other words: machines that are manufactured or operated in Europe must be safe – irrespective of whether they are new or used. Also for economic reasons, any risk that may emanate from a machine, should be avoided from the start. The safety of machines and plants can already be integrated during the planning. With “Safety Integrated”, Siemens provides a complete product and service portfolio for functional safety for automation and drives, which is described in more detail on the Internet at [siemens.com/safety-integrated](http://siemens.com/safety-integrated).

“Safety Integrated” offers seamless integration of safety technology in standard automation. This also applies to installed components such as switchgear, protection devices, control units, sensors, communication equipment, etc. and not only brings advantages in the functional safety, but also:

### Greater economy

- Minimisation of the number of types
- Minimisation of the costs due to only one bus and one engineering system
- More easily reproducible series machines through intelligent software solutions

### Greater standardisation

- Easier to operate through uniform user interfaces
- Can be increasingly reused thanks to the use of libraries
- Fewer control cabinet versions on the machines
- Simplified installation through bus systems

### Greater productivity

- Quick commissioning thanks to pre-wired and certified components
- Shorter downtimes thanks to fast fault localisation and comprehensive diagnostic functions
- Quicker restart after plant modifications
- Production without standstill through additionally available safe, fault-tolerant systems
- Space-, time-, and cost-saving installation

### Greater flexibility

- Tailor-made solutions from a modular system
- Easy expansion and integration in the world of Totally Integrated Automation

- Better chances in the worldwide market through compliance with the required approvals and conformance with the EU directives
- Simplified maintenance and plant expansion thanks to long-term product and system availability

In Europe, machine manufacturers (product safety) and machine operators are legally obligated to guarantee the safety of personnel and the environment. Lots of other countries, in which there are no such legal requirements, are also becoming increasingly aware of this subject. In Europe, “provided” machines must be safe – irrespective of whether they are new or used. For this reason, “provision” has the following meaning: the machine is manufactured or has a major refit in Europe – or it is imported into Europe and operated there.

European directives – such as the Low-voltage Directive, Machinery Directive, EMC Directive, etc. (see Fig. 12/3) – describe the basic requirements for machine manufacturers or plant operators, who modernise and modify their own machines to a large extent.

Compliance with the Machinery Directive can be guaranteed in different ways:

- In the form of a machine acceptance through a certification office
- By satisfying the harmonised standards
- Through a separate safety certificate with increased test and documentation work

The CE marking with the appropriate safety certificate is always the visible proof of compliance with the Machinery Directive. According to the EU Occupational Safety and Health Framework Directive, this is mandatory.

To ensure conformance with a directive, it is recommended that you use the appropriate harmonised European standards. The “presumption of conformity” is then assumed (see Fig. 12/3) and provides manufacturers and operators with legal certainty with regard to the fulfilment of national regulations and also EC (or EU) directives. With the CE marking, the manufacturer of a machine documents the compliance with all relevant directives and regulations in the free movement of goods. Since the European directives are accepted worldwide, their use is helpful, for example, when exporting to countries of the European Economic Area (EEA). The most important standards for functional safety are also listed in Fig. 12/3. Further information is available on the Internet at [siemens.com/safety-infomaterial](http://siemens.com/safety-infomaterial)

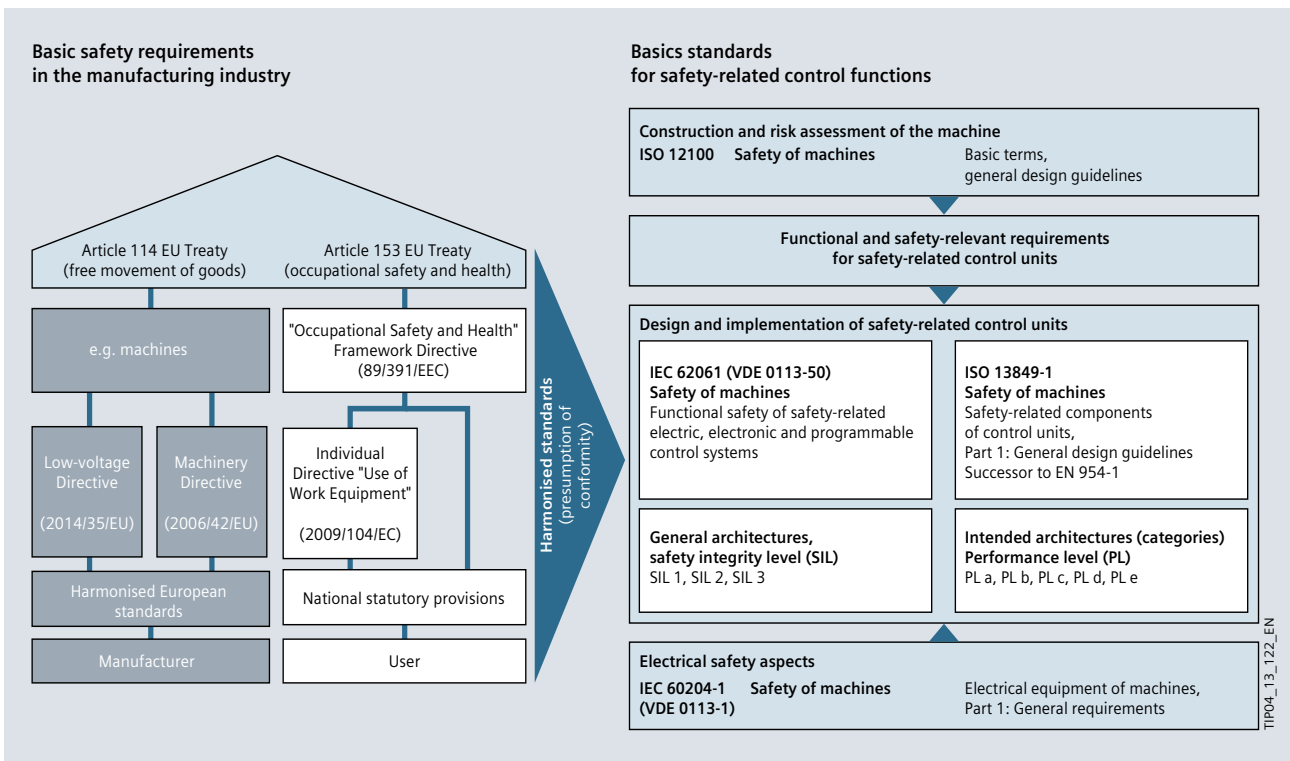

Fig. 12/3: Directives and standards for the functional safety of machines

[back to page 258](#)

Con-  
tents

Intro-  
duction

1

2

3

4

5

6

7

8

9

10

11

**12**

13

14

15

16

17



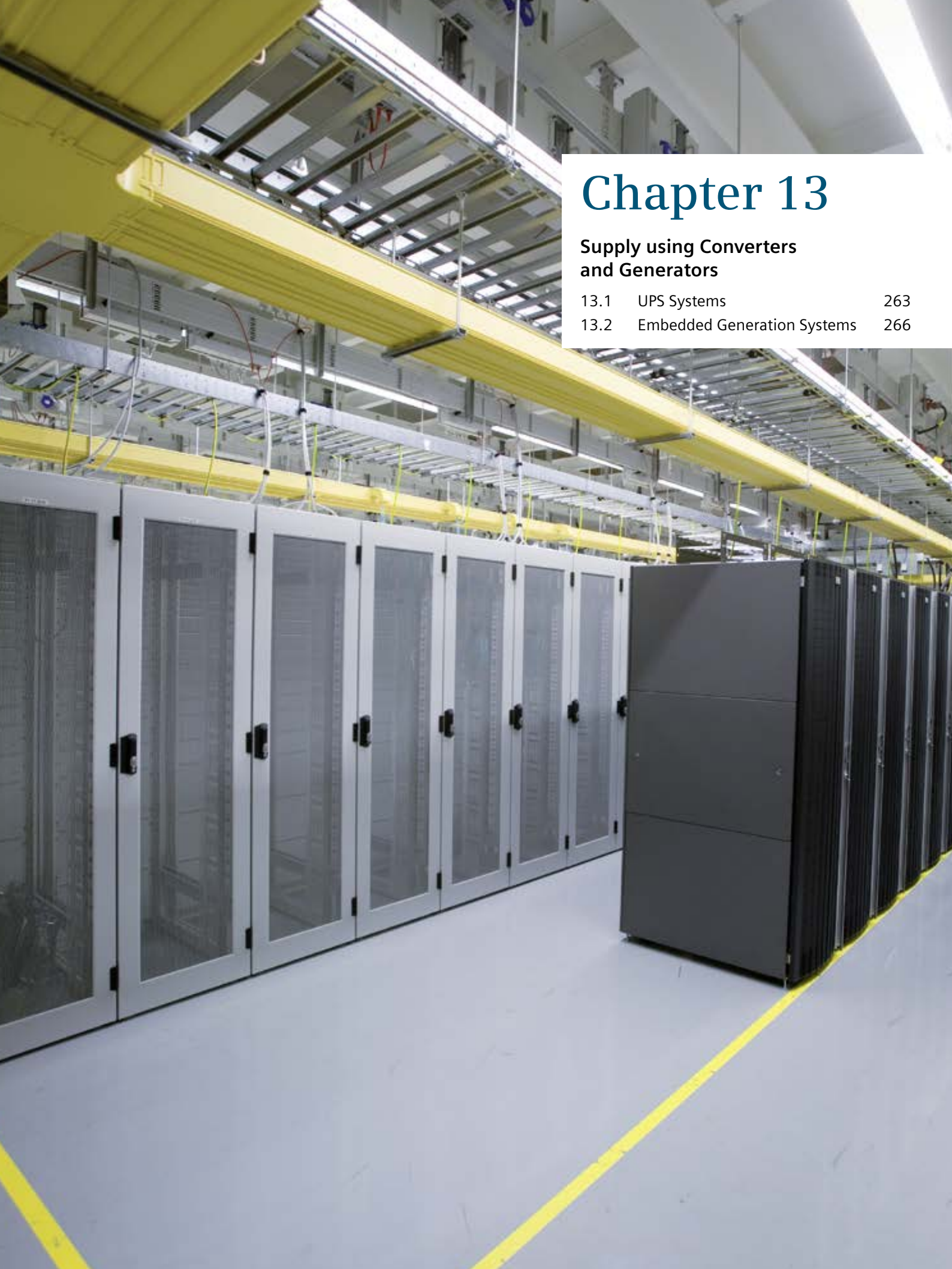

# Chapter 13

## Supply using Converters and Generators

13.1	UPS Systems	263
13.2	Embedded Generation Systems	266

# 13 Supply using Converters and Generators

In the guidelines for the connection of embedded or distributed generation systems, emergency generators are considered as such and a distinction is made according to the connection to the power supply system. The following are defined as power sources for safety purposes according to IEC 60364-5-56 (VDE 0100-560):

- Rechargeable batteries
- Primary cells
- Generators whose drive machine functions independently of the normal power supply
- A separate system feed-in (for Germany, supplemented by a "dual system") from the supply network that is really independent of the normal supply

The VDEW guideline "Emergency generators – Guideline for the planning, installation and operation of systems with emergency generators" (2004 edition) describes the connection conditions for UPS installations and explains the methods of operation of emergency generators in different system configurations (for further information on standby generating sets and uninterruptible power systems, refer to section 13.1 and 13.2).

Electronic components do not only play a part as power consumers (soft starters and frequency converters, see chapter 14) but also as a source of energy. In wind turbines and photovoltaic systems, the generated power is fed in using grid-conforming converters whose perturbations can affect the grid.



## 13.1 UPS Systems

The use of a UPS system is for the protection of sensitive consumers in the normal power supply system (NPS) and to ensure their safe, continual operation during power failures (see Fig. 2/6). The proper integration of the UPS system into the power supply concept is of vital importance for the availability of the entire power supply system. The following general aspects concerning UPS should be considered in the planning:

- Selectivity for the switching and protection function in conjunction with the UPS system
- Disconnect conditions (personal safety in accordance with IEC 60364-4-41, VDE 0100-410) in conjunction with the UPS system
- Factoring in the short-circuit energy  $I^2t$  as well as the short-circuit current  $I_k$  for the static bypass
- Simple, clearly structured network topology (short-circuit behaviour see Appendix 17.1)
- Protection of the UPS main distribution (possible single point of failure SPOF) at the UPS output; in particular in case of a UPS being connected in parallel

Basically, we distinguish between dynamic and static UPS systems.

*Note: If a flywheel is used to supply critical loads via the electronic inverter in case of voltage problems, this is also a static UPS system.*

### 13.1.1 Dynamic UPS Systems

DIN 6280-12 describes the different types of dynamic UPS systems (Fig. 13/1). The two main components of a dynamic UPS system are the electric motor and the generator, synchronised as a machine unit. Following the standard, the critical consumers are supplied by the generator.

However, the machine unit has a low kinetic energy for bridging voltage failures in the millisecond range. This very short period can be extended to a limited time, mostly in the range of seconds or minutes, by using flywheel energy storage and/or battery systems. The bridging time can be extended by connecting a diesel engine. Then, the intermediate storage systems must supply the generator with energy for so long until the diesel engine has run up to speed (Fig. 13/2).

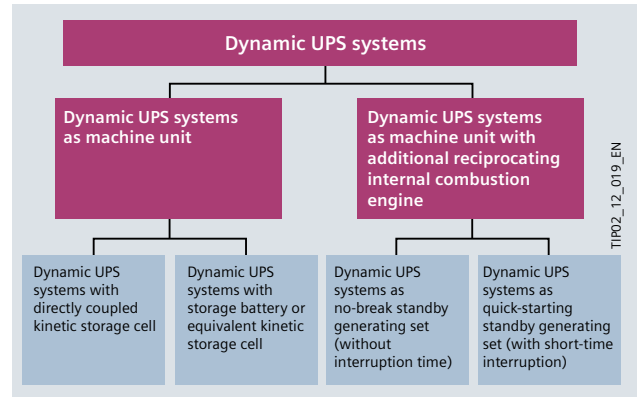

Fig. 13/1: Overview of possible dynamic UPS systems in accordance with DIN 6280-12

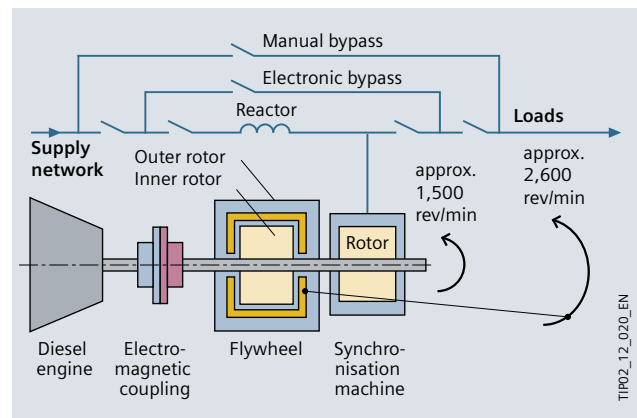

Fig. 13/2: Schematic view of a dynamic UPS system using a combination of diesel engine, flywheel, and generator power

The operating modes of dynamic UPS systems in accordance with DIN 6280-12 permit further distinctions to be made:

- Stand-by active mode (quick-starting – short break: 2 to 500 ms interruption time)
- Continuous operation mode (electrically isolated load supply through UPS: no break readiness)
- Active following mode (uninterruptible transfers between load supply from the normal network and load supply from the synchronised UPS: no break readiness)

Please note that this classification does not correlate with the classification of static UPS systems (see Fig. 13/3). Even in the continuous mode, the dynamic UPS may be frequency-dependent if the line voltage is not transformed into a so-to-speak independent supply voltage for the motor using a converter.

An active stand-by mode, for example, is not feasible for the IT components in the data centre, since manufacturers of power supply units established the ITIC curve described in chapter 5 [4], in which the permissible voltage conditions (see Fig. 5/2) for the power supply of ICT components are described. According to the ITIC curve, a voltage interruption is only permitted for a maximum of 20 ms. The curve was introduced for single-phase 120-V equipment with an AC frequency of 60 Hz. However, it is nowadays used in similar form for many other product series.

### 13.1.2 Static UPS Systems

To influence the supply voltage, power electronic components such as diodes, thyristors, and transistors are used in static UPS systems. Dependent on the influence exercised, IEC 62040-3 (VDE 0558-530) classifies static UPS systems according to the quality of the UPS output voltage and the behaviour in case of line faults (see Tab. 13/1).

The simplified schematic diagrams Fig. 13/3 illustrate that the double conversion principle (VFI, voltage and frequency

independent) provides an independent supply quality for the consumers. In the voltage independent (VI)-UPS, the voltage is set independent of the UPS input voltage, whereas in an off-line circuit (VFD, voltage and frequency dependent) both the voltage and the frequency at the UPS output depend on the conditions at the input. In any case, planning must take into account that grid perturbations and the consumers' load requirements have an influence on the supply at the UPS input.

If a spatial separation of electricity consumers from power supply components is desired, larger, better performing UPS units with a 3-phase connection and double-converter system (on-line UPS system) are usually used. The systems comprising UPS and battery should be accommodated in separate operating rooms for reasons that include ventilation, EMC, noise, maintenance, fire protection, etc.

To increase their performance and improve availability, parallel-connected UPS systems may be used. Do note that with an increasing number of components, the servicing outlay will also increase and that the higher system complexity may cause new kinds of faults. For reasons of usage efficiency, the load-dependent UPS efficiency rate should also be considered in the redundancy concept. Therefore, a (2+1) redundancy may create a somewhat higher availability, leaner maintenance costs, and lower losses in operation, than for instance, a (6+1) redundancy.

Line faults	Time	For example	IEC 62040-3	UPS solution	Supplier solution
1. Power failures	> 10 ms		<b>VFD</b> Voltage + Frequency Dependent	<b>Classification 3</b> Passive standby mode (off-line)	–
2. Voltage fluctuations	> 16 ms				–
3. Voltage peaks	4 ... 16 ms				–
4. Undervoltages	continuous		<b>VI</b> Voltage Independent	<b>Classification 2</b> Line-interactive mode	–
5. Overvoltages	continuous				–
6. Surge	> 4 ms		<b>VFI</b> Voltage + Frequency Independent	<b>Classification 1</b> Double-conversion mode (on-line)	–
7. Lightning strikes	sporadic				Lightning and overvoltage protection (IEC 60364-5-53)
8. Voltage distortion (burst)	periodic				–
9. Voltage harmonics	continuous				–
10. Frequency variations	sporadic				–

Tab. 13/1: Types of line faults and matching UPS solutions based on IEC 62040-3 (VDE 0558-530) [12]

A current trend which may be important for the planning of reliable power supply is the extendibility and redesign capability gained from modular UPS systems. A modular UPS system allows the integration of extension modules into an existing system when performance demands are rising. To this end, a possible final brown field scenario should already be on hand when operation starts. It is frequently argued that although the initial cost of investment is somewhat higher, the investment total can be reduced by the lower cost for the extension modules. Moreover, easy extendibility and fast swapping of modules shall reduce the UPS failure period in case of a fault – thus increasing availability as against a conventional UPS solution.

In this context, it must be kept in mind that initially an investment must be made in oversizing parts of the modular system, which is often worthwhile only if the factual extension corresponds to the planned scope of extension. Above that, the plant operator binds himself to a specific UPS model so that the framework parameters for subsequent purchases of modules may best be considered prior to the first purchase. Model changes make subsequent purchases much more difficult and expensive in most cases.

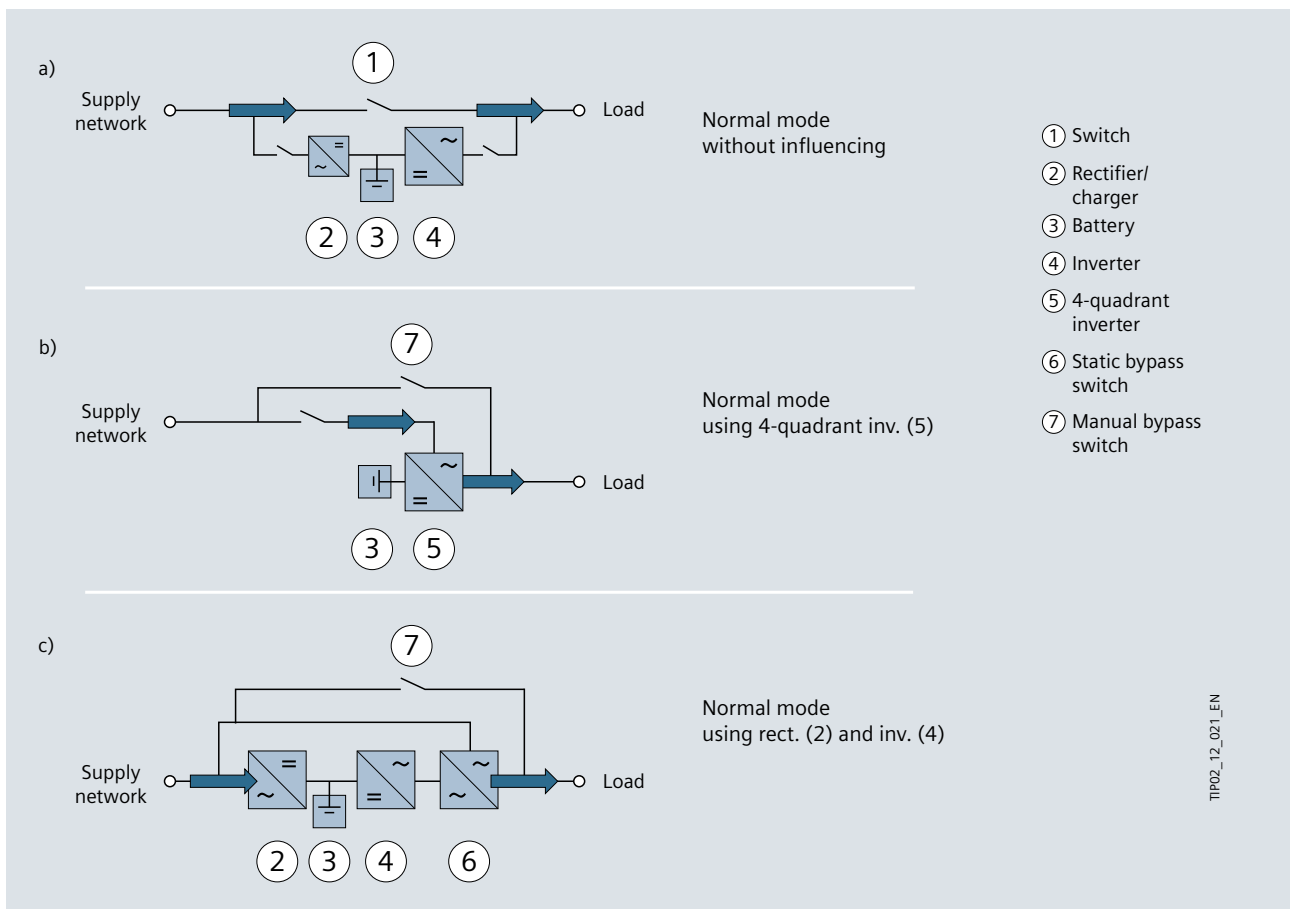

Fig. 13/3: UPS systems with energy flow during normal operation:  
 a) Off-line UPS system (VFD)  
 b) Line-interactive UPS system (VI)  
 c) On-line UPS system (VFI)

[back to page 264](#)

## 13.2 Embedded Generation Systems

When an embedded electric power generation system is connected to the low-voltage grid of the distribution system operator (DSO), German regulations require that the VDE application rule VDE-AR-N 4105 [13] is applied. The "Technical supply conditions for connection to the low-voltage power system" (TAB 2007; [14]) must also be taken into account.

1-phase connections can be used for embedded generation systems with a rated apparent power of less than 4.6 kVA (for photovoltaic systems below 5 kWp), 3-phase connections for systems greater than this. a control point with disconnect function that can be accessed by DSO personnel at all times must be provided. Alternatively, an "Installation for monitoring the power supply with assigned switching devices in series" with test certificate based on DIN V VDE V 0126-1-1 can be used. a tie breaker must ensure an all-phase, electrical isolation. The requirements of IEC 61000-3-2 (VDE 0838-2) or IEC 61000-3-12 (VDE 0838-12) must be fulfilled for operating an embedded power generation system.

If a standby power supply system is planned anyway, it must always be verified whether a combined heat and power station (CHP) can be operated cost-effectively with regard to the overall energy concept. As a rule, an investment is justified when the payback period does not exceed seven years, or in certain cases, ten years. Whereby, in the long term, it should be possible to obtain substantial revenues from the surplus power and / or heat.

An additional improvement in the utilisation can be achieved by combining a combined CHP with an absorption refrigeration unit. As no chlorofluorohydrocarbons (CFHC) are used, this is an environmentally friendly alternative to conventional refrigeration units.

In addition to the capital costs, the following points should be clarified for estimating the profitability of CHP operation:

- The location of the combined heat and power station
- The requirements for the simultaneous use of heat / refrigeration and power
- The control of the fuel supply
- The heat / refrigeration management to cover reserve and peak loads
- The power management to cover reserve and peak loads
- Service and maintenance
- Dedicated qualified personnel

### 13.2.1 Standby Power Generating Set

An emergency standby power system (ESPS) supplies electricity in case of an outage of the public supply. It may be required in order to

- Fulfil statutory regulations for installations for gatherings of people, hospitals, or similar buildings
- Fulfil official or statutory regulations for the operation of high-rise buildings, offices, workplaces, large garages or similar buildings
- Ensure operation of safety-relevant systems such as sprinkler systems, smoke evacuation systems, control and monitoring systems, or similar systems
- Ensure continuous operation of IT systems
- Safeguard production processes in industry
- Cover peak loads or to complement the power supply from the normal grid

#### Dimensioning of the generator units

DIN 6280-13 and the ISO 8528 series of standards apply for the dimensioning and manufacturing of standby generator units. The design class of the generator unit results from the load requirements. The following factors, among others, are relevant for the power rating of the generator units:

- Sum of connected consumers = consumer power (about 80% of the nominal output of the generator unit, keep an eye on critical consumers such as pumps)
- Operating behaviour of the consumers (e.g. switched-mode power supply units, frequency converters, and static UPS units with high power distortions, observe harmonic content  $\leq 10\%$  for standard generator units)
- Simultaneity factor  $g = 1$
- Turn-on behaviour of the consumers
- Dynamic response and load connection response of the generator unit (the standard value for the first load injection step is about 60% of the generator unit output)
- Ambient conditions at the installation site of the generator unit
- Reserves for expansions
- Short-circuit behaviour (see Appendix 17.1)

#### General

First a distinction is made between a power generating unit and a power generating station. The power generating unit is the actual machine unit comprising drive motor, generator, power transmission elements and storage elements. The power generating station also includes the auxiliary equipment such as exhaust system, fuel system, switchgear and the installation room (Fig. 13/4). This then constitutes

a complete standby power supply system. The purpose of use and the design have not been taken into account yet.

### Integration into the power supply concept

The following selection criteria for the standby generating set must be taken into account because of the consumer-dependent boundary conditions of the SPS such as power requirements, power distribution concept, simultaneity factor, and reserves for expansions:

- Supply at the medium-voltage or low-voltage level
- Distribution of the SPS load over several standby power generating sets connected in parallel or supply via one large standby generating set
- Central installation or distribution of the individual power supplies close to the SPS consumers

The differences in the cabling of the safety power supply, the breakdown susceptibility of the control system, the expense for switching and protection measures as well as the supply of the consumers "privileged" to receive emergency power during maintenance and repairs must be taken into account in the selection and concept finding process. Some of the decisive criteria for making a choice between the medium-voltage and the low-voltage level are listed as seen from the medium-voltage viewpoint.

Medium voltage has the following advantages:

- Larger loads can be transmitted more easily over longer distances

- Better power quality in extensive networks (voltage drop)
- More favourable energy purchase price for power consumption (clue: approx. 20% advantage over low voltage)
- The required short-circuit current is attained much easier in the TN-S system for the "Protection through disconnection" measure.

Medium voltage has the following disadvantages:

- Cost effectiveness should be checked when the power requirement is less than approximately 400 kVA
- Expenses for the protection concept rise with the size of the networks
- (Additional) transformers with the associated switchgear and appropriate protection are also required in the network for the safety power supply
- More devices and material are required
- A higher qualification of the operating personnel is required

Generally, a medium-voltage supply is only cost-effective if high power quantities must be transmitted over large distances.

### Turn-on and operating behaviour of consumers

The start-up or turn-on behaviour of electric motors, transformers, large lighting systems with incandescent or similar lamps has a major effect on the generator unit output.

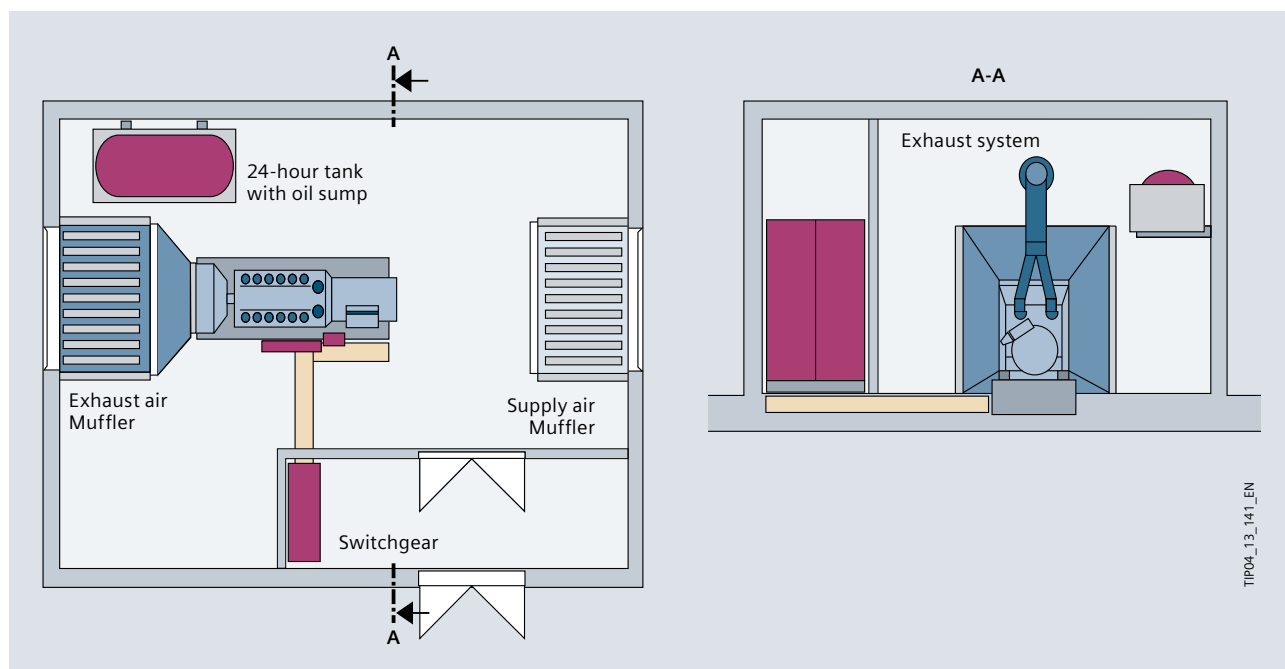

Fig. 13/4: Typical arrangement of a stationary standby power generating set

Especially when there is a large proportion of critical consumers in relation to the generator unit output, an individual test must be performed. The possibility of staggering the connection of loads or load groups significantly reduces the required generator unit output. If turbocharger motors are used, the load must be connected in steps.

All the available possibilities of reducing the start-up loads of installed consumers should be fully exploited. The operation of some consumer types can also have a major effect on the generator unit output and generator design. a special test must be performed when supplying consumers by power electronic components (frequency converters, power converters, UPS).

**Dynamic response**

The dynamic response of the generator unit at full-load connection and for the load changes to be expected must be adapted to the permissible values of the consumers. The design class of the generator unit in accordance with ISO 8528-5 is determined by the consumer type or the relevant regulations concerning voltage and frequency conditions. Fulfilling the required values can result in an oversizing of the engine, generator or both components.

As a rule, modern diesel engines with turbochargers – and possibly charge air cooling – are usually not suitable for load connections greater than approximately 60% in one load impulse. If no particular consumer-related requirements are set as regards the generator unit, the load connection must be performed in several steps.

**Short-circuit behaviour**

If no particular measures are taken, the unit generators supply a 3-phase sustained short-circuit current of approx.  $3 \text{ to } 3.5 \cdot I_n$  at the generator terminals. Because of these small short-circuit currents, special attention must be paid to the shutdown behaviour (personal safety IEC 60364-4-41; VDE 0100-410). An oversizing of the generator may be required in such cases. As the active power may exceed the value of the rated generator unit power when a short circuit occurs, the diesel engine may also have to be oversized in this case.

**Room layout and system components**

When planning the generator unit room, the local building regulations must be taken into account. The planning of the generator unit room can also have a significant influence on the acquisition costs of a standby power supply system. The installation room should be selected according to the following criteria:

- Short cable routes to the supply point (low-voltage main distribution board)
- The room should be located as far away as possible from residential rooms, offices, or similar (offending noise)
- Problem-free intake and discharge routing of the required air flow rates
- Arrangement of the air inlets/outlets taking into account the main wind direction
- Problem-free routing of the required exhaust pipe
- Easy access for moving in the components

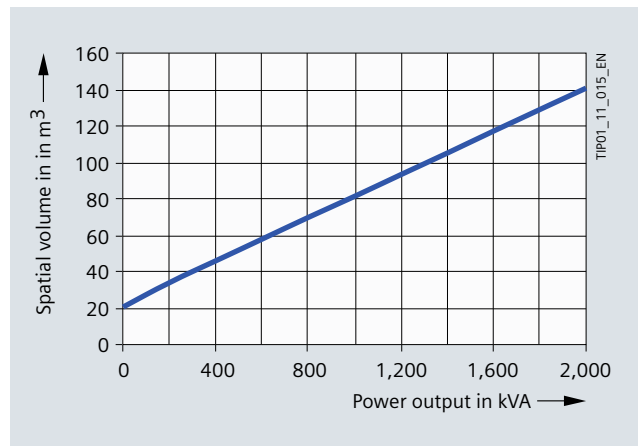

Fig. 13/5: Space requirements of a complete standby power generating set including soundproofing [back to page 269](#)

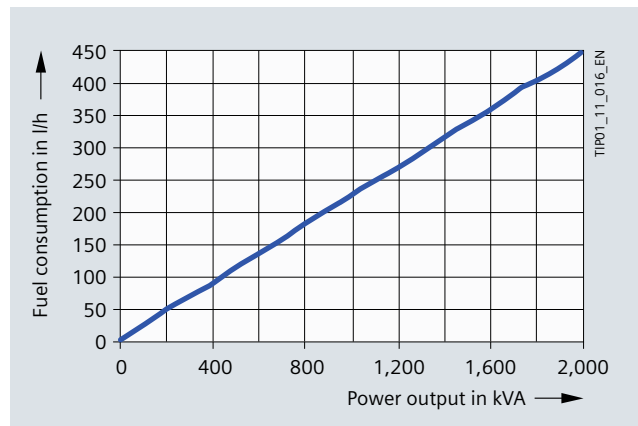

Fig. 13/6: Hourly fuel consumption in relation to the rated power [back to page 269](#)



The intended generator unit room must be selected so that is it large enough to easily accommodate all the system components. Depending on the installation size, there should be 1 to 2 m of access space around the generator unit. The generator unit room should always have a temperature of at least + 10°C in order to prevent condensation and corrosion forming and to reduce the engine preheating (Fig. 13/5).

### Tank facilities

Diesel fuel or fuel oil can be used for diesel generator units. Each generator unit tank facility should have enough fuel for 8 hours of operation at full load (Fig. 13/6). Facilities that are subject to IEC 60364-7-710 (VDE 0100-710) must be dimensioned for at least 24 hours of operation at full load. In tank facilities for emergency power supply, the fuel level must be at least 0.5 m above the injection pump of the diesel engine. In many cases, in particular for systems in continuous operation, it may be better to divide the tank facilities into a 24-hour tank and a storage tank. The 24-hour tank then remains in the generator unit room with capacity to suit the available space. The storage tank can then be installed in another room, or designed as an over-ground tank for outdoor installation or as an underground tank. The 24-hour tank is refuelled by means of an automatic filling device.

### 13.2.2 Wind Turbine

A wind turbine basically consists of the rotor system, the nacelle with the generator (directly driven or geared), the frequency converter, and the tower. A certified monitoring and control system is crucial for the continuous adjustment of operating parameters to the actual wind conditions. Every wind turbine requires reliable auxiliary power supply in order to supply the many auxiliary circuits (for example for the electric control system, air conditioning, navigation lights, hoisting gear, lighting, and the lift) (Fig. 13/7).

In just 20 years, the revenue from wind turbines was raised by a factor of 50. While capacities of about 3 MW are being installed onshore today, turbines in the windier offshore sector are now sized with about 6 MW. Manufacturer development centres are already working on 10 to 15-MW turbines, which will lead to further multiplication of revenues (Fig. 13/8).

The electrical grid conditions for operating wind turbines are specified in the IEC 61400 (VDE 0127) series of standards. These parameters are relevant among others:

- The voltage corresponds to the nominal value in accordance with IEC 60038 (VDE 0175-1)  $\pm 10\%$  (for small wind turbines with a rotor area  $\leq 200 \text{ m}^2$ , the tolerance is  $\pm 20\%$  in extreme conditions)
- The frequency corresponds to the nominal value  $\pm 2\%$  ( $\pm 10\%$  for small wind turbines in extreme conditions)

- The phase asymmetry (ratio of the voltage's negative-sequence component to the positive-sequence component) shall not exceed 2% (15% for small wind turbines in extreme conditions)
- Automatic reconnection period(s) must be within 0.1 s and 0.5 s for the first reconnection (between 0.2 s and 0.5 s for small wind turbines) and for a second reconnection between 10 s and 90 s

The design of the electrical installation of a wind turbine must meet the requirements on machine safety in accordance with IEC 60204-1 (VDE 0113-1). Stationary equipment, not the machine installations, must meet the requirements of the IEC 60364 (VDE 0100) series of standards. The manufacturer must specify which standards were applied. The rating of the electrical installation must take account of the varying power output of the wind turbine.

It must be possible to disconnect the electrical installation of the wind turbine from all power sources in such a way that maintenance work or inspection can be performed without any hazard. Semiconductor devices must not be employed as disconnecting devices on their own. For example, an air circuit-breaker can protect the main circuit against overload and short circuit. It is also used for safe disconnection from supply during maintenance work. Locking devices preventing unauthorized reconnection ensure optimum safety for the maintenance personnel. Equipped with communication options, the air circuit-breaker can be optimally integrated into the electronic systems of the wind turbine. Lightning protection for a wind turbine must be designed in accordance with IEC 62305-3 (VDE 0185-305-3). Overvoltage protection for a wind turbine must be built up according to the requirements of IEC 62305-4 (VDE 0185-305-4). The selection and installation of the earthing system (earth electrode, earth conductor, main terminals, and busbars for earthing) must be designed in compliance with IEC 60364-5-54 (VDE 0100-540).

Important components for connecting the wind turbine to the electric power supply grids of the DSO are: transformers (for transforming the low voltage into medium voltage), medium-voltage switchgear, control systems, meters, and main substations, as shown in Fig. 13/9. To complement regulations, local grid connection requirements of the grid operators must often be fulfilled, as described in the technical guidelines of the BDEW [15, 16] and the wind energy promoting association Fördergesellschaft Windenergie (FGW) [17]. The requirements of Germanischer Lloyd [18, 19] are of international importance in the certification of onshore and offshore wind turbines.

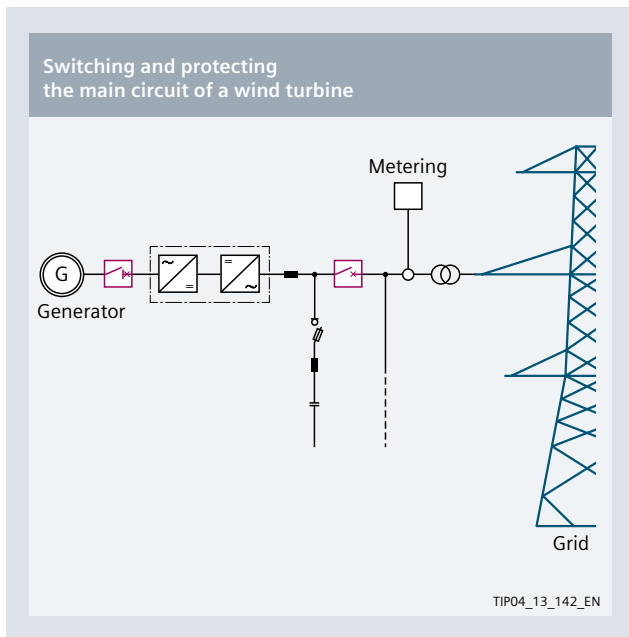

Fig. 13/7: Circuit diagram for connecting the wind turbine into the supply grid

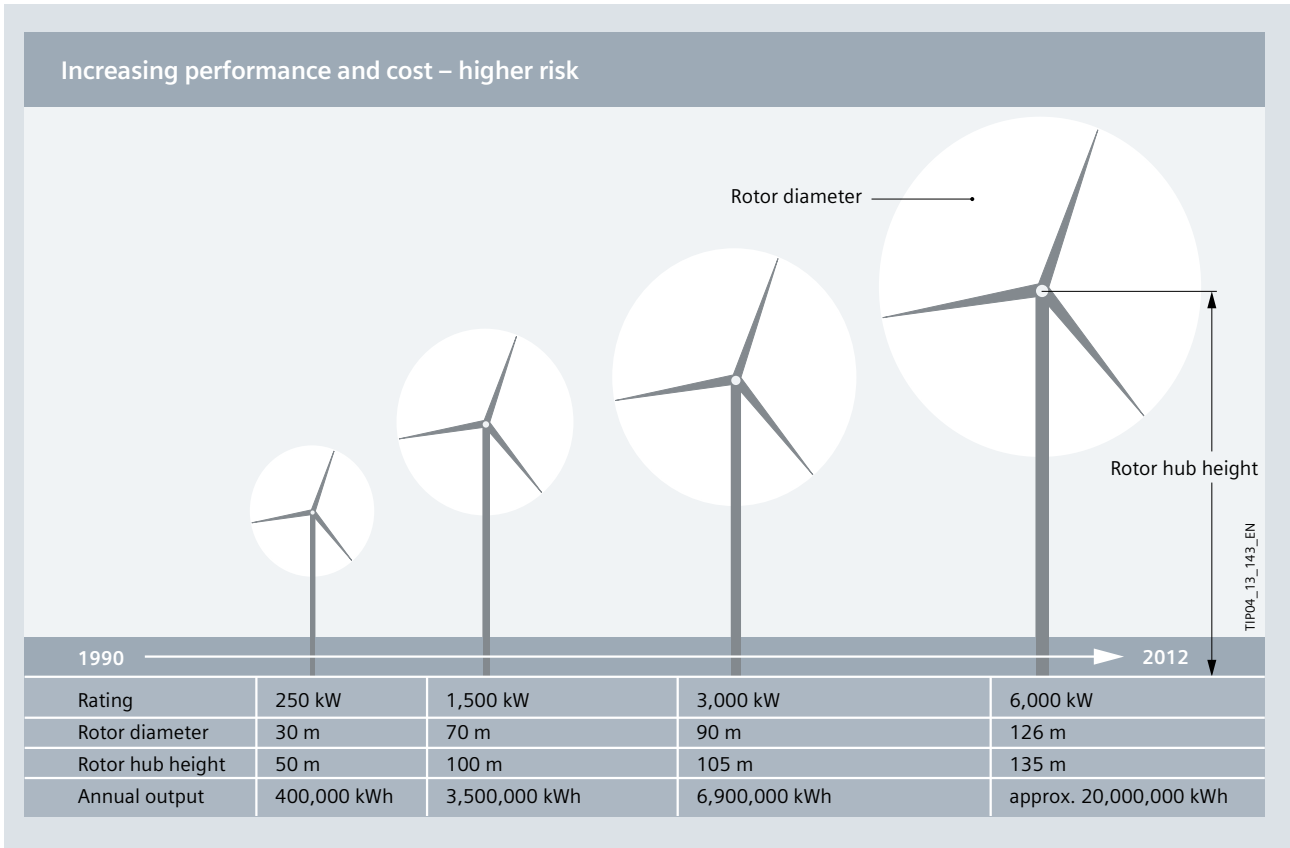

Fig. 13/8: Technical development of wind turbines from 1990 until 2012

[back to page 270](#)

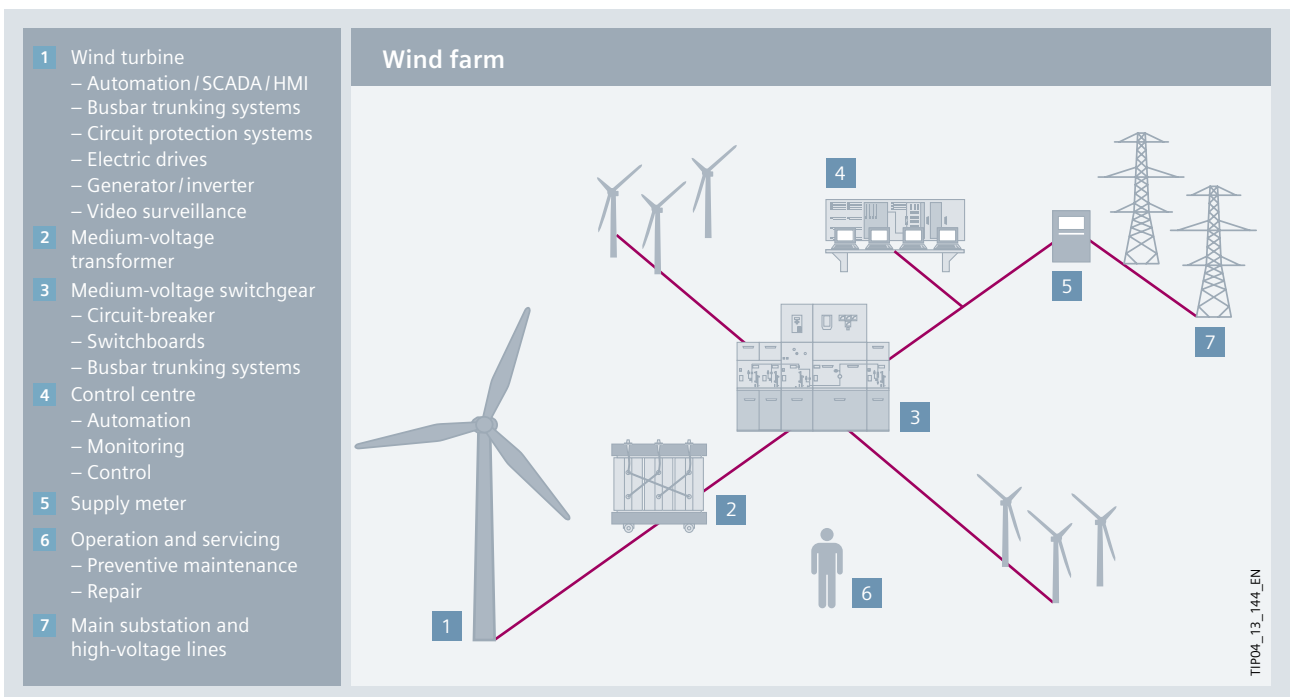

Fig. 13/9: Embedding wind turbines into the electric power distribution grid

[back to page 270](#)

### 13.2.3 SIESTORAGE Energy Storage System

Electric power generation based on renewable energies is a key element for restructuring a strongly fuel-oriented energy business towards more sustainability. Besides water power, wind and solar energy play the crucial part in this context. The use of renewables on a large scale, however, leads to new challenges for grid stability: Producers of wind and solar energy are usually not capable of providing short-circuit power, which is a measure for grid stability. When energy generated from distributed sources is fed into the grid, the energy flow may sometimes be reversed. This can result in damage on equipment and power outages in distribution grids not designed for this situation. Power generation from renewable sources naturally varies to a great extent. This quite often causes imbalances between generation and load, which impairs the stability of the grid. Operators of distribution grids are increasingly faced with the question, how a sufficient amount of control power can be provided to ensure a constantly high quality of power supply.

Energy-efficient business activity is of great importance for industrial firms and facility management companies as well as for enterprises in the infrastructure sector in order to keep their energy costs as low as possible. Even exceeding the maximum power demand agreed with the power supplier once may incur high costs. Moreover, even the shortest interruption of power supply can lead to a com-

plete failure of production plants. Such a failure means an enormous loss of quality and time, along with noticeable financial damage.

#### Storage characteristics

Traditional energy storage systems (Fig. 13/10) cannot necessarily ensure stable grid operation in the lower distribution grid levels today. a storage solution is called for which above all provides control power for primary control almost instantaneously, from distributed sources and with sufficient capacity, until the power stations have run up. Important characteristics of the supply grid which are positively influenced by energy storage systems are:

- Increased power quality
- Integration of distributed renewable energy sources into the grid
- Deployment of control power reserves
- Improved voltage and supply quality
- Flexibility in peak load management

Another important field of application for energy storage systems is the emergency power supply of sensitive industrial production processes, data centres, and hospitals. Furthermore, there are energy storage solutions for energy-efficient buildings, isolated networks, and smaller independent grids for in-plant demand, for public transport, and for electro-mobility applications.

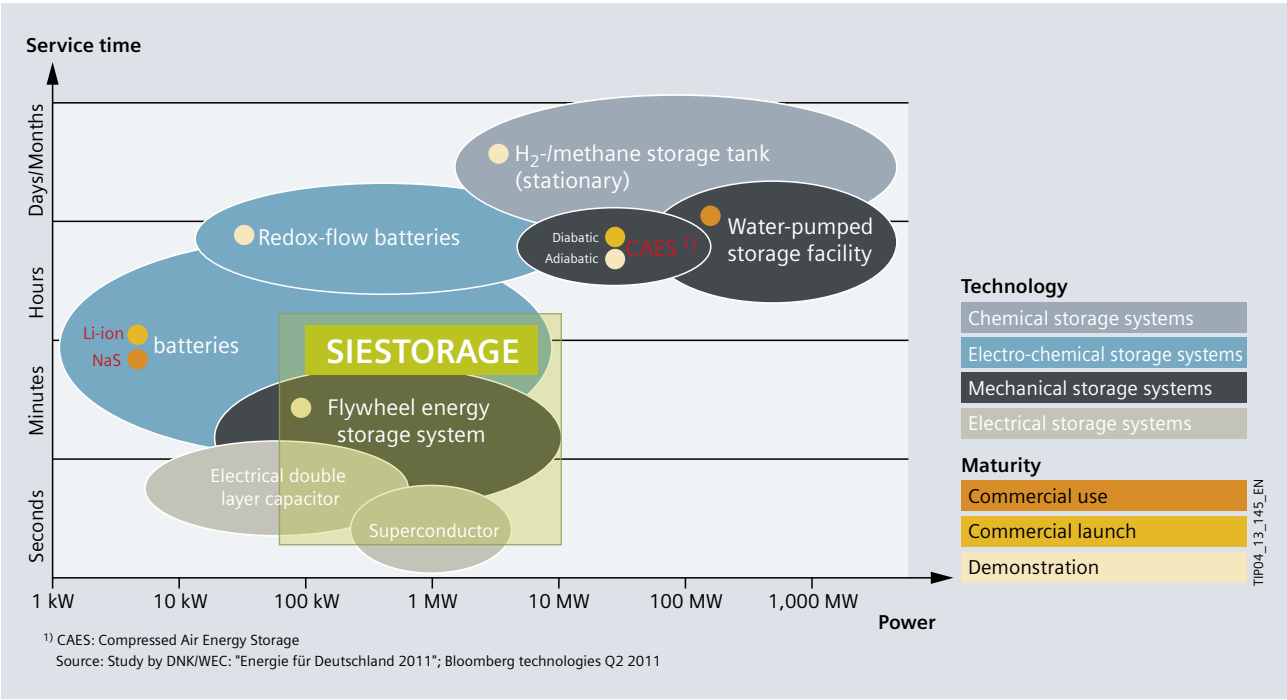

Fig. 13/10: Comparison of the service times of energy storage technologies

SIESTORAGE is an advanced energy storage system. The modular "Siemens Energy Storage" (SIESTORAGE) system combines ultra-modern power electronics for grid applications with high-capacity Li-ion batteries. With a capacity of approximately 2 MWh, it can supply up to 8 MW power. Due to its modular design, SIESTORAGE is suitable for many applications. SIESTORAGE balances variations in the generated power within milliseconds, thus ensuring stable grid operation (Fig. 13/11). This energy storage solution enables an increasing amount of solar power plants and wind turbines to be integrated into distribution grids without that these grids need to be immediately extended themselves. Furthermore, SIESTORAGE makes for a self-contained, reliable power supply for isolated networks with renewable energy sources. In addition, the Siemens solution safeguards fault-free power supply in industrial plants and building facilities and helps avoid expensive load peaks.

Operator benefits from using SIESTORAGE:

- High availability and reliability owing to a modular system
- A great variety of applications owing to proven experience in power electronics for grid applications
- Complete integration from a single source throughout the entire life cycle
- High man and machine safety through safe handling of the battery modules (safe extra-low voltage)
- Self-contained power supply, reliable owing to black-start capability
- Environmentally friendly solution: No emissions

### Load variations

It is imperative that power generation follows such load variations. If this is not the case, deviations from normal voltage are the consequence. The permissible voltage deviation as part of the power quality is specified in the EN 50160 standard. Observance of this standard is up to the grid operators. They must ensure that 95% of the 10-minute means of the r.m.s. supply voltage value for every weekly interval are within the range of  $U_n \pm 10\%$  under normal operating conditions without failures or supply interruptions. As a result of the liberalisation of the energy market, the roles of grid operators, electricity suppliers, and power generators are now separated by jurisdiction as well as by business administration, which aggravates this task. Owing to the legal framework, more and more distributed power generators are integrated into the grids. To let renewables play a more prominent part, the obligation to purchase such energy quantities was introduced for grid operators on the one hand, and power generation for one's own use was subsidized on the other. But at the same time, the grid operators bear the risk for the consequences of load variations on the electricity grid. Therefore, grid operators draw up forecasts, for example for large-scale consumers and in a summarized form even for entire cities. Besides such already common forecasts, the forecastability of feed-in from renewables is playing an increasingly important role. But with every forecast, grid operators run the risk of misinterpretation of actual consumption.

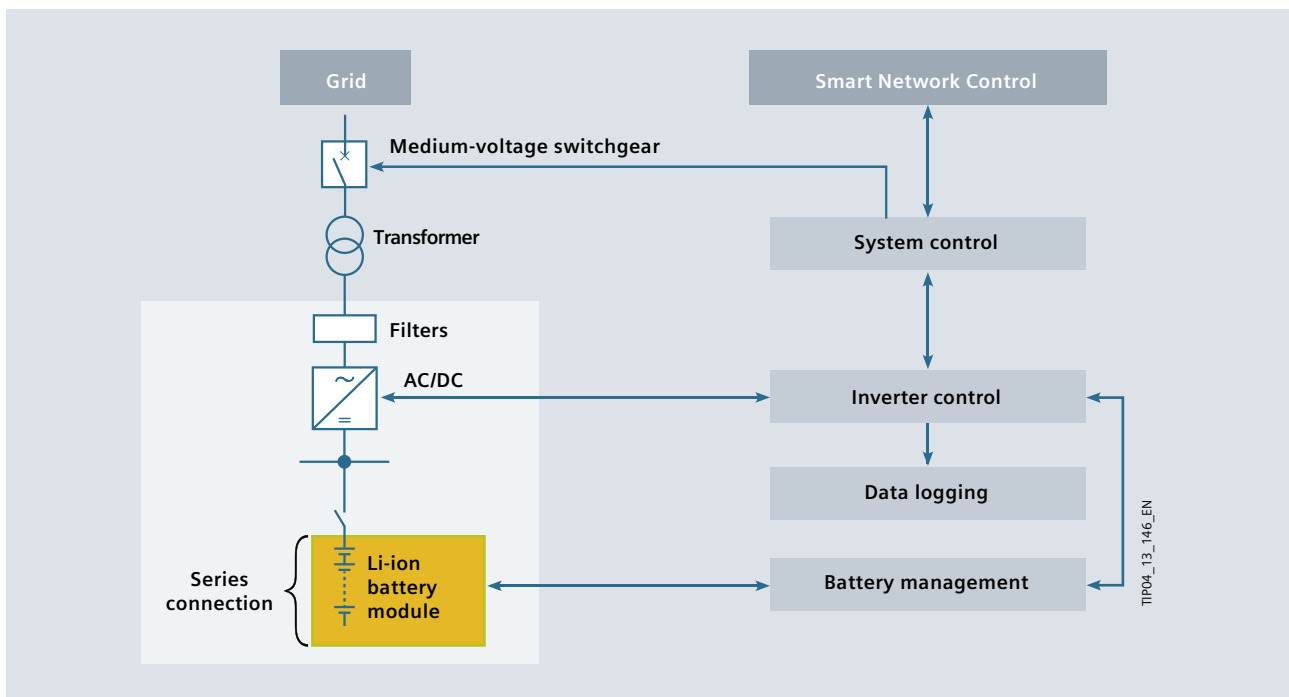

Fig. 13/11: Schematic design of SIESTORAGE

If the customer takes over the risk of such fluctuations, this will become noticeable in a better pricing. This energy demand forecast, known as schedule clause in 1/4-h electricity supply contracts, is gaining increasingly more importance in this context (Fig. 13/12). The customer submits to his distribution system operator (DSO) a forecast of his energy demand (EU-wide always on Thursdays), in which optimisations at 24-h notice are permitted. The procurement of these forecast energy quantities is up to the electricity supplier. Depending on what was contractually agreed, the customer is permitted deviations in the range of  $\pm 5\%$  or  $\pm 10\%$ , for example. So far, forecasts are optional for the customer and result in more favourable price conditions. But in the long run, they will become mandatory with smart grids paving their way.

**Example for the interaction of power generation from a photovoltaic system and energy storage**

In the future, the profitability of a photovoltaic (PV) system will rise with the share of self-consumed solar electricity. Therefore, the goal of a combined PV and energy storage system will be to completely consume the self-generated power and simultaneously achieve a good forecastability of the power drawn from the distribution grid operator (Fig. 13/13).

Two vital factors which are to be observed when planning a combined system are the size relations between power generation and storage plus the so-called C factor for the charging / discharging characteristic of the storage system. The C factor is defined as the quotient from the current and capacity of an accumulator.

$$C \text{ factor} = \text{current} / \text{charge} = 1 / \text{time (output / accumulator capacity in h}^{-1}\text{)}$$

*Example: When a storage system with a capacity of 400 Ah is discharged, a C factor of 2 C means that a current of 800 A can be output. Vice versa, with a C factor of 6 C, a continuous charging current of about 2,400 A can be assumed for recharging. To establish the charging duration, a charge efficiency (also called charge factor) must be considered which is to integrate the charge-current-dependent heat developed during the charging process.*

In our example, we assume a sunny load curve for power deployment by a PV system with a power peak of 1,000 kWp (index p for peak) as shown in Fig. 13/14. a possibly feasible scenario assumes feed-in with an ideal PV curve whose output peak is adapted daily to the forecast noon peak for

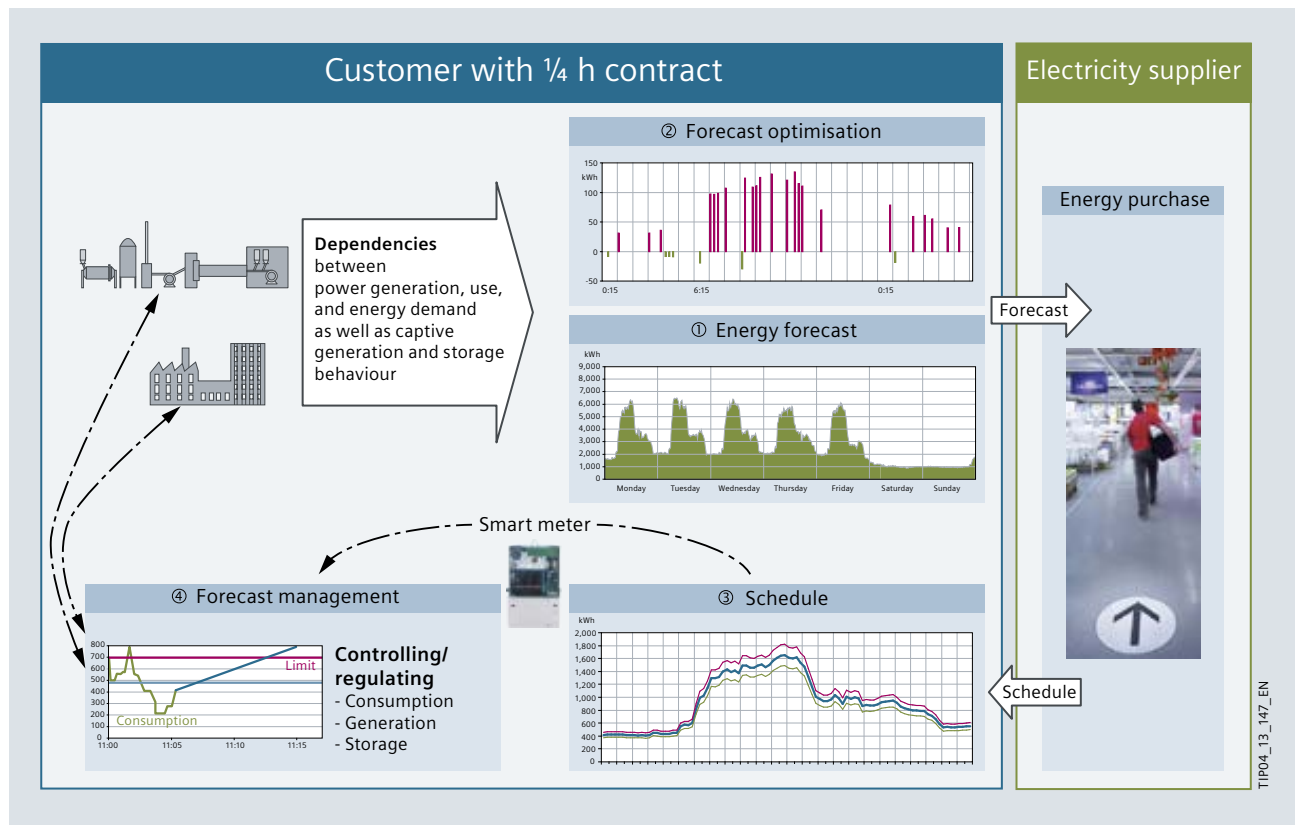

Fig. 13/12: Transparency of the energy flows

sun radiation. The difference between power generation from the PV system and the feed-in curve of the scenario defines the sizing of the SIESTORAGE energy storage system. We expect that the storage system is completely discharged at the beginning of the assessment period (storage content 0 kWh).

For the evaluation, the difference quantities between power generation and hourly mean feed-in are formed. a positive difference means that the storage system is being charged during the hour under assessment, whereas it is discharged in case of a negative result. The required storage capacity of the SIESTORAGE results from the difference between the maximum and minimum value of this weekly curve in each case. No statement is made about costs and C factors, since this is always a project-specific task.

The evaluated scenario assumes a forecast for sun radiation. The peak value for the feed-in curve is then calculated day-specifically in such a way that it yields the forecast energy quantity together with the ideal PV curve shape, which is equal to the energy quantity from the PV output curve for the individual day. Though the peak of the ideal

PV curve thus varies in amplitude (Fig. 13/14), the energy balance at midnight is always equalized (Fig. 13/15).

In this case, the storage capacity needed amounts to about 900 kWh, so that two standard storage containers with a total capacity of 1 MWh will be sufficient. The maximum charging power per hour which will be fed into the storage container from the PV system is 350 kW, and the maximum power drawn is 200 kW. Hence a C factor of 3 C is sufficient. In this scenario, the investment required is within acceptable limits so that a business assessment could be worthwhile.

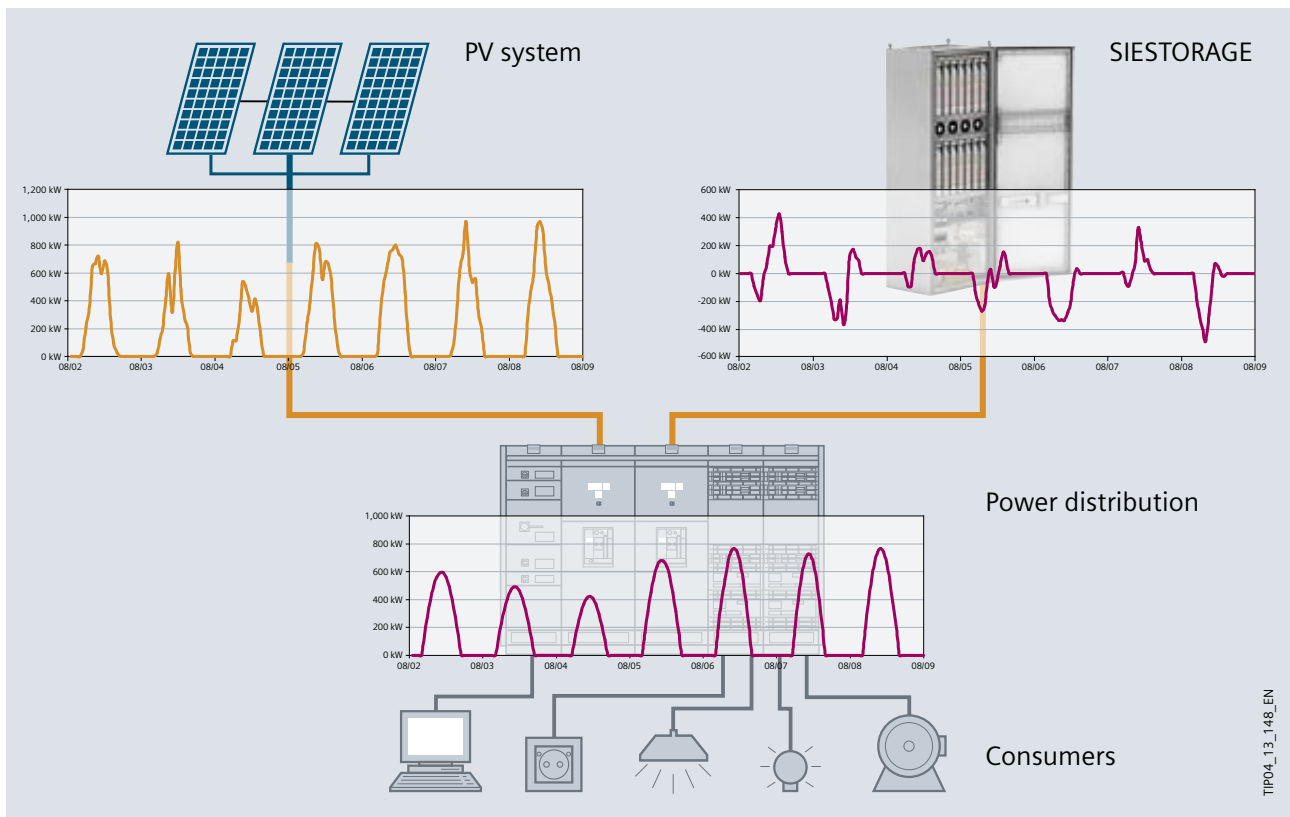
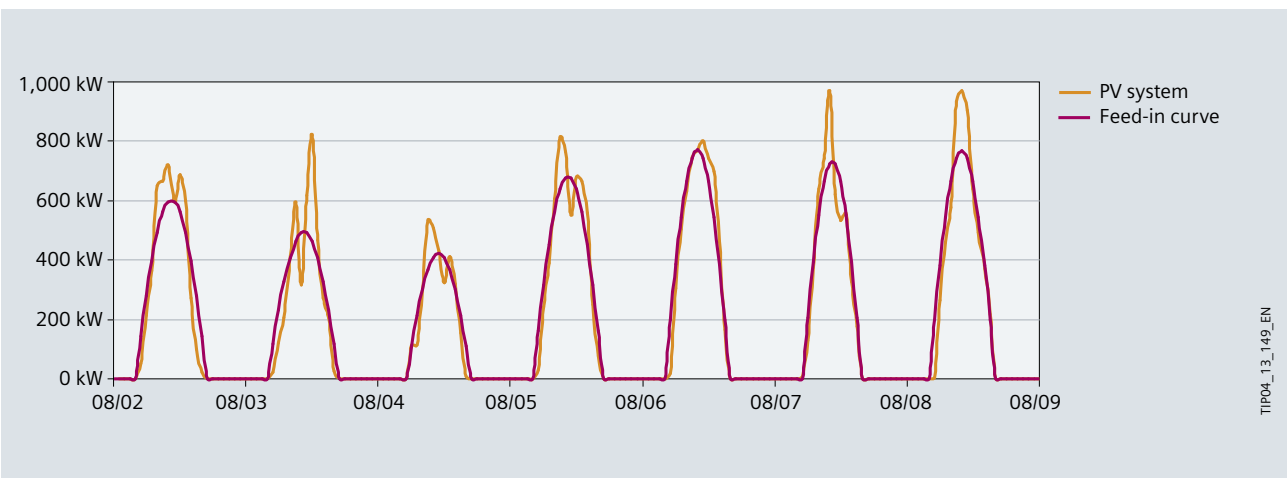

Fig. 13/13: Power supply concept integrating photovoltaics and a SIESTORAGE energy storage system

[back to page 274](#)



TIP04\_13\_149\_EN

Fig. 13/14: Weekly curve of PV power and the desired feed-in power according to the forecast about sun radiation provided the day before [back to page 274](#)

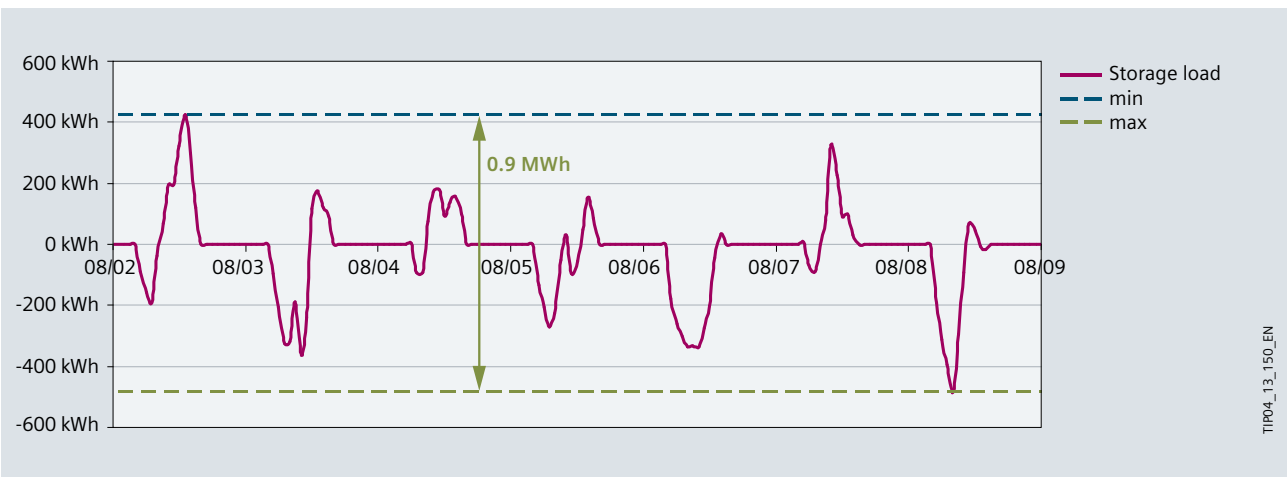

TIP04\_13\_150\_EN

Fig. 13/15: Weekly curve of the energy required which a storage system is to supply, respectively take in, based on the power ratios from Fig. 13/14 [back to page 275](#)



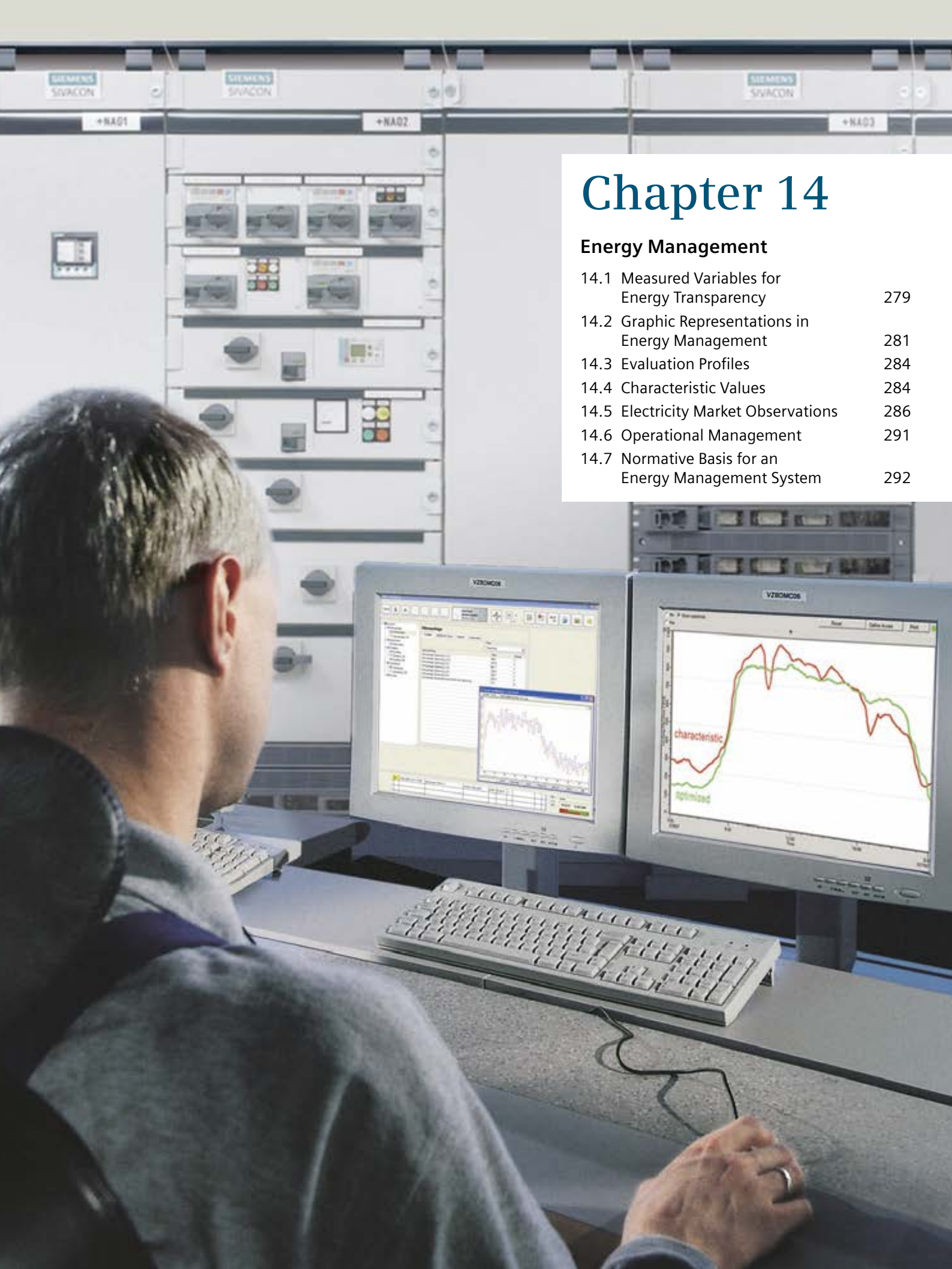

# Chapter 14

## Energy Management

14.1 Measured Variables for Energy Transparency	279
14.2 Graphic Representations in Energy Management	281
14.3 Evaluation Profiles	284
14.4 Characteristic Values	284
14.5 Electricity Market Observations	286
14.6 Operational Management	291
14.7 Normative Basis for an Energy Management System	292

# 14 Energy Management

1

High supply and operational reliability as well as flexible use are the key factors of every modern power distribution system. In view of the increasing share of energy costs in the overall operating costs of a building, an operating cost optimisation is a planning criterion which should not be neglected. Essential elements are an ecologically and economically focused optimisation of energy consumption and thus of energy costs. Even in the design stage, energy analyses are called for. When basic data is established and pre-planning work is carried out, which corresponds to phase 1 and 2 according to the Regulation of Architects' and Engineers' Fees (HOAI) in Germany, targets must be agreed upon as to the kind of energy to be utilised and the measuring systems to be employed and an energy concept must be developed.

2

3

4

5

6

7

8

9

10

11

12

13

14

15

16

17

Based on the energy flows in the building, energy transparency, energy management, and energy efficiency all interact. Data collection and processing ensure energy transparency on which energy management as a process is based. a building's energetic efficiency is directly influenced by the integration of automation systems and the definition of energy efficiency levels for the equipment based on client specifications (Fig. 14/1).

## Energy efficiency

Energy efficiency specifies the relationship of use to outlay. Differing efficiency considerations are possible such as energy consumption, time, overall costs, operating costs, and environmental burdens. Often individual criteria are consciously combined in efficiency considerations to substantiate a conclusion reached. Relations between differing factors can also be drawn. For instance, consideration can be given in an eco-balance to the relationship between material deployment at the manufacturing stage and energy consumption under operations. As the degree of efficiency is physically clearly defined as the relationship between active power for use to the total active power to be applied, it must not be put on the same footing as energy efficiency.

## Energy transparency

Energy transparency creates the data basis for actions, reactions, handling instructions, and improvements. Basically, energy transparency is part of operational management, since energy flows can only be analysed with precision in practice. Even so, it is often overlooked that the measuring, evaluation, and data management systems are the basis for energy transparency.

## Energy management

The VDI 4602 Sheet 1 guideline defines energy management as follows: "Energy management is the clear-sighted, organisational, and systematized coordination of procurement, conversion, distribution and usage of energy to meet requirements whilst taking ecological and economical objectives into account." All resources enabling this coordination are defined in this directive as energy management systems: "Energy management systems comprise the organisational and information structures required to put energy management into practice. This includes the technical resources involved, such as software and hardware."

If energy management requirements are to be considered in addition to personal and system protection, measuring instruments as part of electrical power distribution must also be factored in. This is necessary in order to verify the implementation and operation of an energy management system such as ISO 50001. For the planning work, this means identifying measuring points at an early stage, defining the scope of measurements and specifying measuring instruments. Without metrology there is no energy transparency and thus no energy management.

Even during the planning process, electrical designers are increasingly expected to consider the life cycle costs. However, the limits established when dimensioning the electrical energy distribution are unsuitable for determining the cost for losses which reflect actual operating conditions. The power losses of transformers, busbar trunking systems, and cabling figure prominently in life cycle cost calculations under the envisaged operating conditions. Current is factored in with its square value.

For an ohmic load, power loss  $P_v$  is calculated from (current  $I$ , specific resistance  $R$ ):

$$P_v = I^2 \cdot R$$

The cost losses are the product of electricity price and power losses. However, without a realistic load curve for the period under review, it is not possible to obtain an estimation of power consumption that reflects operating conditions. After all to establish the energy losses, the time-specific power losses characterised by the load curve are integrated by way of the period under consideration and – in connection with the electricity prices – the contribution to the life cycle costs is defined.

On average, 5% of the energy procured is dissipated into heat as energy losses within an electrical power distribution system. Owing to consumption-optimised dimensioning of individual distribution system components, such as transformers, busbar trunking systems, and cables in keeping

with the load curve, there is an absolute energy saving potential of up to 1% (in relation to the 5% power loss in the whole power distribution system, this means a relative saving of 20%) – really a non-negligible dimension over a period of 20 years. Under the aspect of life cycle costs, the optimisation of transformers, busbar trunking systems, and cabling should be part of the standard scope of services in present-day engineering and electrical design and thus should be requested and/or offered.

### 14.1 Measured Variables for Energy Transparency

Feed-in, transformers, and generators are dimensioned on the basis of their apparent power  $S$  in kVA. Currents measured in a are crucial for the busbars, cabling, protection and switching devices integrated in the electrical power distribution system. Loads are always factored with their active power  $P$  in kW and associated power factor  $\varphi$  into the distribution dimensioning. If these electrical quantities, which served as the planning basis, are to be substantiated during the actual operation, appropriate measuring devices need to be provided. When allocating the energy consumed to different cost centres, the quantity of work or energy  $W$  (in kWh) within the feed-in system and for every power consumer to be allocated must also be measured.

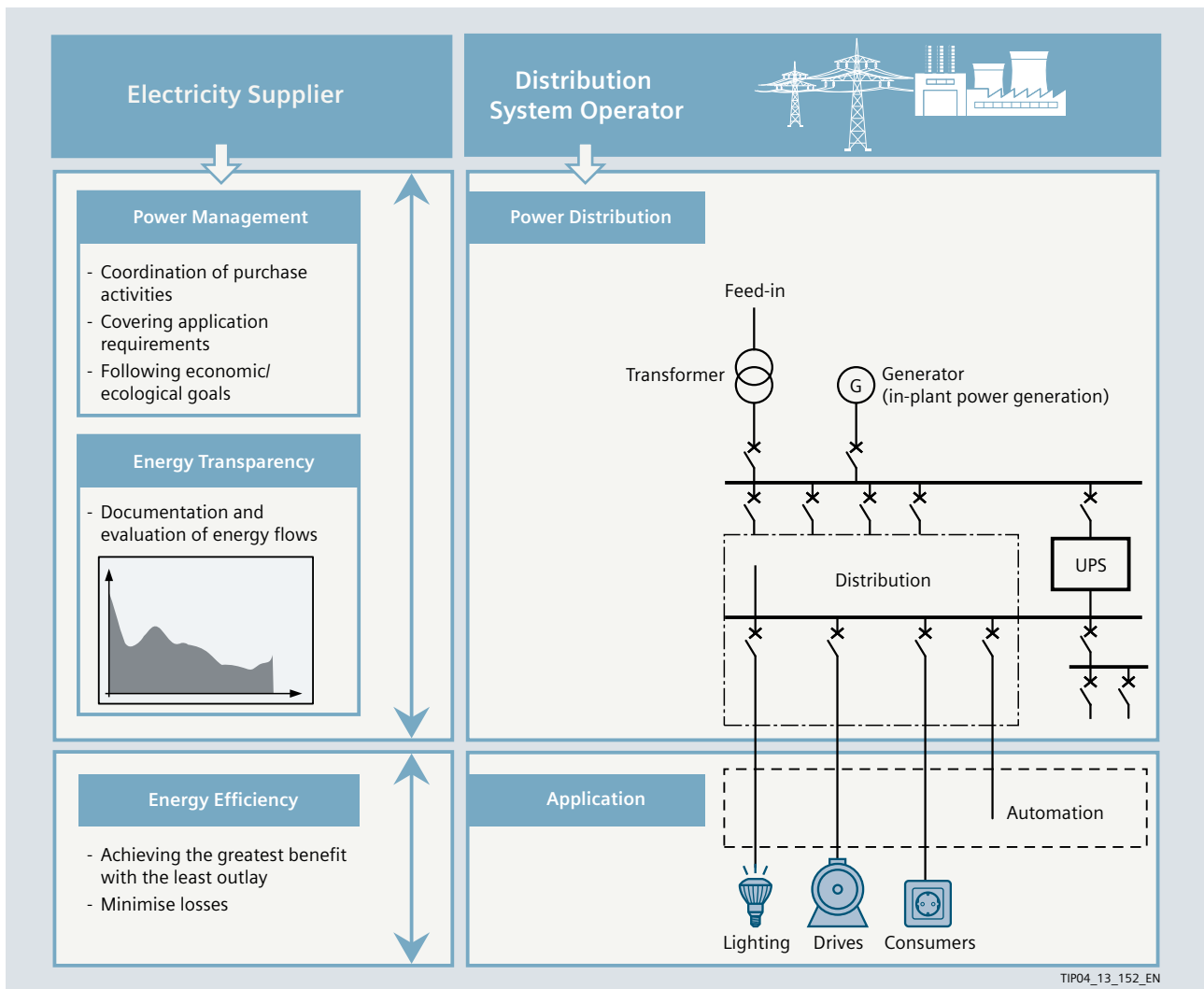

Fig. 14/1: From energy management to energy efficiency with the help of energy transparency

[back to page 278](#)

To ensure transparency of plant operation, it is useful to measure voltage  $U$  in V, current  $I$  in A, the power factor, and total harmonic distortion  $THD$  (recorded separately for the voltage and current) as the sum of all harmonics in addition to the above-mentioned apparent power (Fig. 14/2), a generator is treated like a transformer, but in addition, the produced energy  $W$  must be measured in kWh.

Leased or tenant areas are billed on the basis of electricity consumption  $W$  in kWh. An electricity meter records the consumption. Here it must already be clarified in the planning stage, whether this meter must be a calibrated meter for billing purposes. a non-certificated electricity meter is quite adequate given that cost-centres are internally invoiced. For billing purposes it is essential that an MID-conforming instrument is used in accordance with the European 2004/22/EG Measurements Instrument Directive (MID).

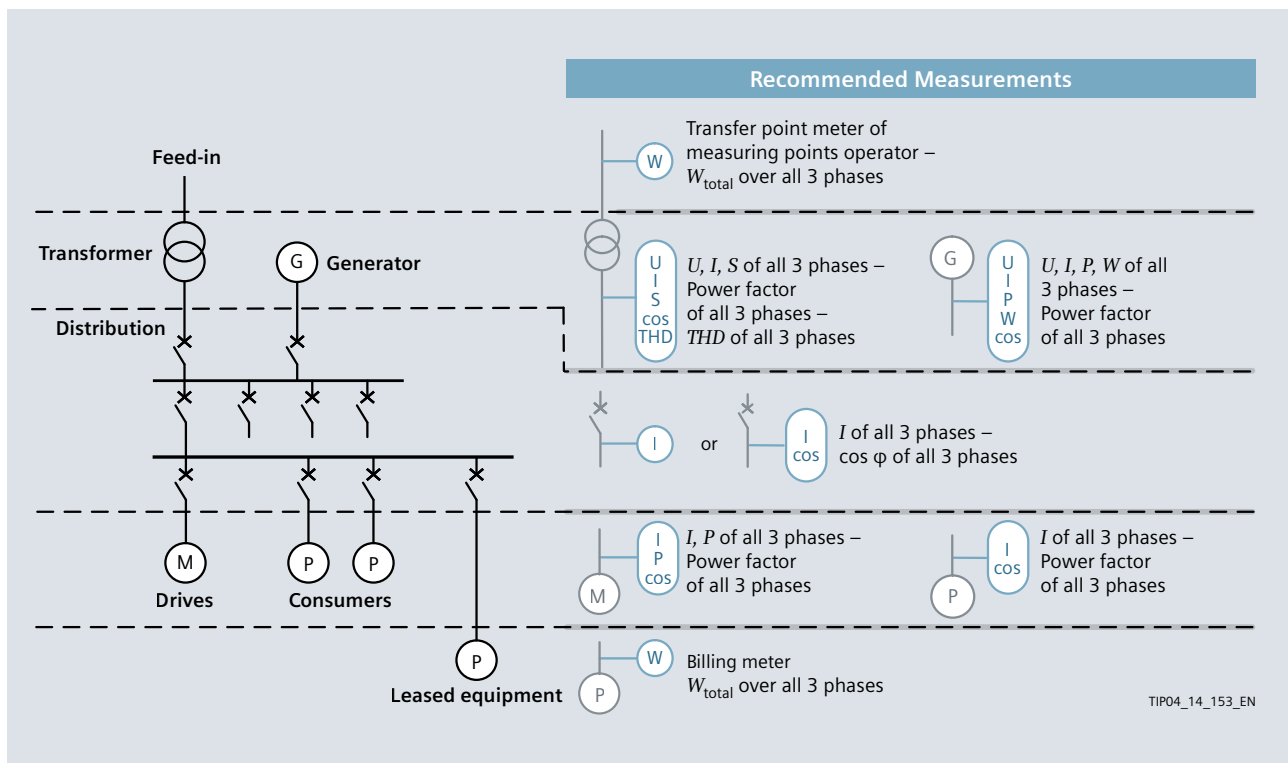

Fig. 14/2: Recommended measurements for the individual supply areas

Permissible voltage drop	for lighting	for other electrical equipment
Low-voltage installation supplied directly from the public grid	3 %	5 %
Low-voltage network supplied from a private power supply network <sup>*)</sup>	6 %	8 %

\*) The voltage drop is preferably not to exceed the values for public grids

Tab. 14/1: Permitted voltage drop in accordance with IEC 60364-5-52 (VDE 0100-520) from the distribution network/consumer installation interface to the connection point of an item of equipment (mains equipment up to 100 m in length)

## 14.2 Graphic Representations in Energy Management

The measured values as rows of figures constitute the basis for various graphics in an energy management system. Normally, users can only understand the response of individual system components and the interconnection between energy usage and corresponding energy demand by analysing the graphs of the measured values.

*Note: Owing to their time relation, mean values of power output and power consumption determined at 15-minute intervals can be derived from one another.*

- Measurement: Mean active power  $P$  in kWh at 15-minute intervals  
Mean energy consumption  $E = P \cdot 0.25$  h
- Measurement: Mean energy consumption  $E$  in kWh at 15-minute intervals  
Mean active power  $P = E / 0.25$  h

### Load curves

Load curves are graphs of measured values in their chronological order. Time is entered on the X-axis, measured values are entered on the Y-axis.

A one-year load curve (Fig. 14/3) starts with the measured value of the first day of the year at 00:15 a.m. and ends with the value of the last day of the year under consideration at 24:00 p.m. The mean values are entered at 15-minute intervals, beginning with the full hour. For performance curves, the average power output of a 15-minute interval is entered over the corresponding period. a graphical representation as load curve allows for the following typical analyses:

- When was it necessary to purchase considerable quantities of power?
- Is there a typical energy consumption behaviour (e.g. a typical time/power pattern)?
- Are there correlations over time with pronounced changes in the measured power values?
- How high is the base load?

Please note that with a mixed utilisation of a building, an analysis needs to be undertaken of the specific load curves relating to the different applications. Such analyses can be offered as services to tenants and building users. Depending on the resolution of the time axis, even more specific interpretations, such as consumption behaviour in special situations or trends, become feasible.

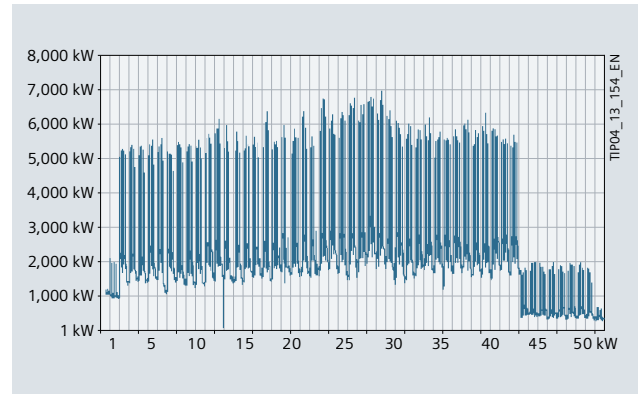

Fig. 14/3: Yearly load curve for a measuring point

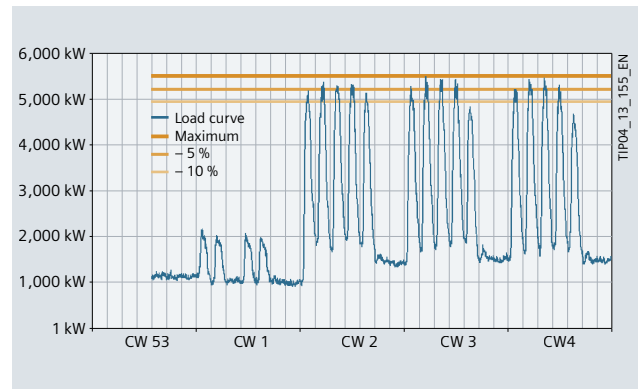

Fig. 14/4: Monthly load curve for a measuring point

The evaluation of yearly load curves is suitable for providing an overview on:

- Load pattern
- Continuity over months
- Electricity peaks at certain points in time over the year
- Seasonal variations
- Operating holidays and other special operating situations
- Minimum performance requirements as load base

The graph of a monthly load curve (Fig. 14/4) may be utilised to demonstrate a possibly typical behaviour:

- Similarities of power purchase
- Continuity at the weekends
- Purchased power over night (i.e. power consumption)
- Base load
- Bank holidays/bridging days/weekends and other 'operations closed' days

The weekly load curve (Fig. 14/5) brings out clear day-specific differences:

- Daily demand
- Daily variations
- Typical work-shift patterns
- Demand peaks

Individual 15-minute intervals are entered in the daily load curve (Fig. 14/6) so that, for instance, the following points can be recognized:

- Precise representation of the daily demand and moments of change
- Breaks
- Work-shift changes

**Synthetic load curves**

Even during building planning phases, statements as to the life cycle costs – lying from the planning viewpoint well into the future – are increasingly expected as they are operation-linked. This means in planning the electrical distribution of power that consideration should be given to the possible energy costs for the power/heat losses of, for instance, busbar trunking systems, switchgear, and cables. Estimations for the maximum operating currents as needed in designing the appliances usually produce unrealistic maximum values for the energy costs, as if the assumption was one of a permanent operation under maximum power. However, as no load curves for a real power flow are known of in the planning phases, the only way is to use a theoretically established course of the time-dependent power demand and resulting energy consumption. Synthetic load curves are at the core of these kinds of theoretical estimations and are based on coming as close as possible to the anticipated consumption pattern during operation.

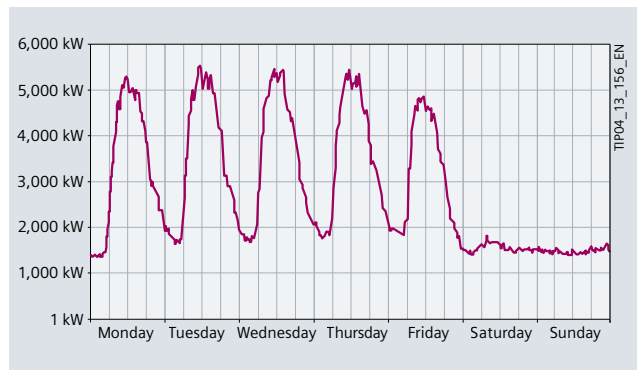

Fig. 14/5: Weekly load curves for a measuring point

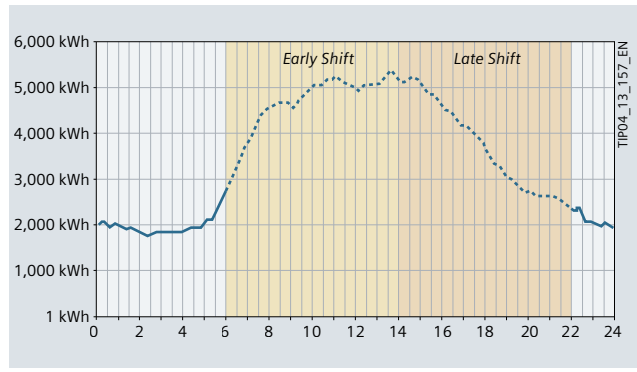

Fig. 14/6: Daily load curve for a measuring point

The synthetic load curve approach expects that technical installations and buildings of comparable use react in a similar way, also in terms of energy consumption – and that, in particular, the pattern of the time-dependent changes is the same. The correlation between future expectations and past findings allows the energy consumption and thus some of the life cycle costs to be systematically determined.

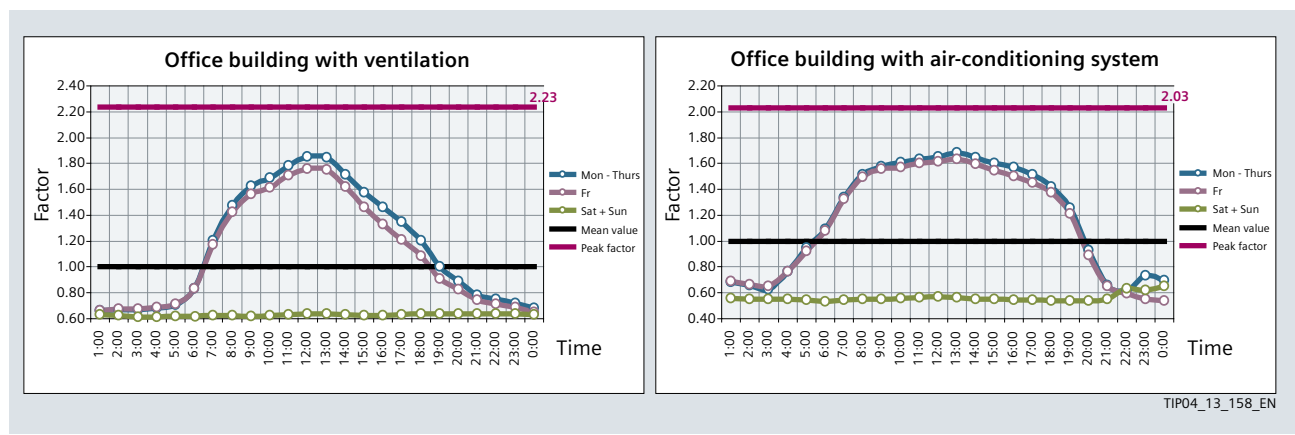

Fig. 14/7: Examples of synthetic load curves for specifying the power consumption in offices

[back to page 283](#)

*Note: For the life cycle costs it is also a matter of scheduling the depreciation or reinvestments for replacement of components as well as service and maintenance. This is where both technical and economic aspects have a major role to play.*

To estimate energy losses in the planning process, the loss can be integrated across the service life through the synthetic load curves. The requirement here is for the course of the curve to be cyclically repeated, for instance, for a day during the planned operating behaviour. Conditional upon the use patterns, consideration can, of course, be given to different, day-specific load curves as, for instance, the differences between office working days and weekends and public holidays as well as possibly the vacation period.

The modelling for building use can, of course, also be elaborated upon. For instance, the synthetic day load curves of an office with air-conditioning differ from those of a natural-ventilated office (see Fig. 14/7). At the same time, various curves can be drawn and evaluated for rooms of different uses in the building, such as those solely fitted out with desks and for canteens and kitchens in office buildings. Process-specific cycles such as shift, charge or batch operation periods can be chosen for industrial processes.

The peak factors indicated in Fig. 14/7 represent the maximum credible power values and serve as the basis for dimensioning the electrical power distribution. In so doing, consideration is usually given to an additional safety margin for the peak factor. The synthetic load curves are standardised to the mean value for the cycle period under consideration. In Fig. 14/7, a weekly cycle is chosen and account is taken of each day of the week for the mean value. The Monday to Thursday synthetic load curves and the Saturday and Sunday weekend are averaged in such a way that for the weekly cycle only three load curves are needed for calculation.

*Note: Power consumption values are laid down in guidelines and standards which can be utilised for classifying the mean values. Where as the German VDI Guideline 3807-4 takes into account the entire electric power consumption for buildings, the values from EnEV 2009 only consider the electricity demand for the heating, ventilation and air-conditioning installations in them, thus ignoring the electricity needed for building use itself.*

Our TIP Consultant Support provides personal planning assistance in the analysis of losses for transformers and busbar trunking systems. With the aid of given synthetic load curves, they can – by using the values established in SIMARIS and the selected products – carry out a loss and cost analysis. This can be followed up by comparing energy

and costs with the Siemens portfolio products. To illustrate the matter, the power losses of selected GEAFOL transformers are entered in Fig. 14/8. This permits a direct comparison to be made between different capacities. The synthetic load profiles (with the number of operating hours shown at a certain power demand above the related load value, see section 14.3) for an identical power range resulting from the synthetic load curves for the various building types serve to make it clear that raising the power by forced ventilation of the transformer is sometimes appropriate or that selecting a larger transformer involving a greater investment provides for benefits in operation. This kind of comparison is calculated in the SIMARIS tool available to the TIP Consultant Support contact partner.

*Note: If on establishing a larger transformer in SIMARIS design a renewed calculation comes about, then other, usually larger appliances can be dimensioned.*

The use of synthetic load curves for the sub-sections of an electric power distribution system allows separate simultaneity factors to be established in SIMARIS design by adding the subordinate synthetic load curves. These factors are then subsumed in one simultaneity factor for rating. This has the added advantage that with a single factor the rating is better suited for subsequent utilisation.

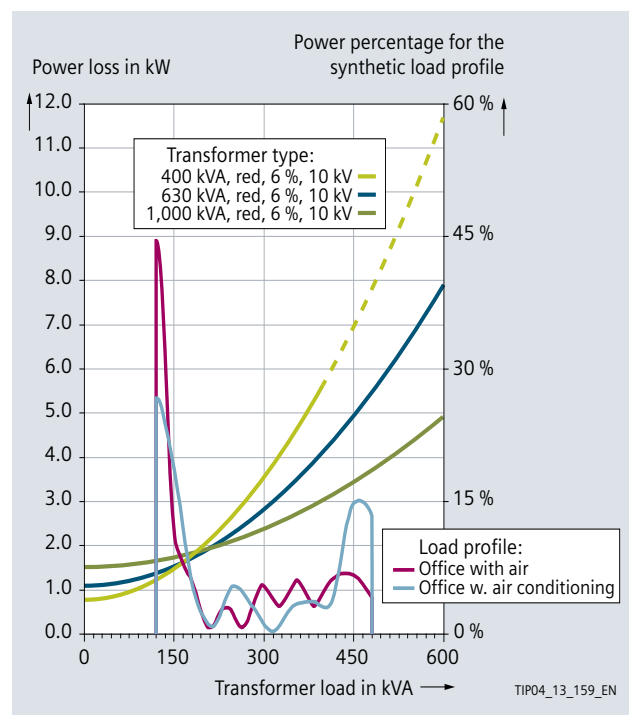

**Fig. 14/8: Comparison of the power losses of various GEAFOL transformer types (high voltage 10 kV, red = reduced losses, rated short-circuit voltage  $u_{zr} = 6\%$ ) and synthetic load profiles for office building types**

### 14.3 Evaluation Profiles

To emphasize correlations, characteristic power values, and typical conditions by graphics, the measured values are processed in different evaluation profiles. These are for example

- Load profile
- Frequency distribution
- Evaluation of maxima

#### Load profile

In terms of the load profile, the power values are shown on the X-axis and the number of hours in which the respective value was measured are shown on the Y-axis. The power profile, which is based on the power values measured every 15 minutes, starts with the base load and ends with the maximum purchased power. The load profile allows you to identify power core areas, meaning the most frequently required power values of a plant or system (Fig. 14/9).

#### Frequency distribution

The frequency distribution is a statistical complement of the load profile by depicting cumulated values. It can be read from the frequency distribution (Fig. 14/10) as to how many operating hours a power range has been drawn. The number of hours is shown on the X-axis with the curve reflecting the power range from 0 up to the respectively indicated upper power limit (Y-axis). In (Fig. 14/10), for instance, a power quantity of 2,000 kW or less was drawn for approx. 4,800 hours in the year. Conversely, the power demand was more than 2,000 kW for approx. 3,760 hours.

Since the number of hours is shown in an ascending fashion, the frequency distribution curve begins with the maximum purchased power and ends with the base load. The frequency distribution allows conclusions to be drawn

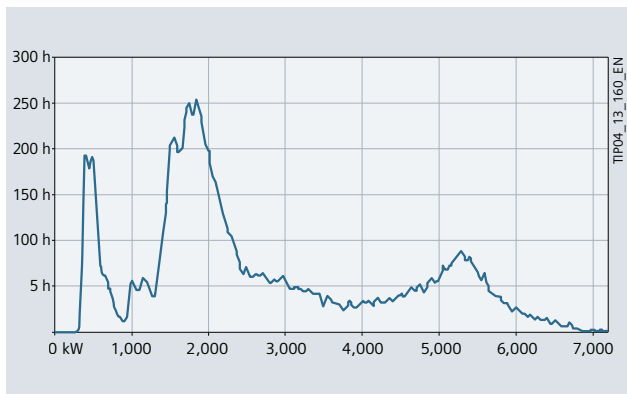

Fig. 14/9: Load profile of a measuring point over one year

as to the continuity of power purchase. In particular, deviations from the mean curve progression allow such conclusions to be drawn. Typical evaluations gained from frequency distributions are:

- Load peak characteristics
- Electricity purchase continuity
- Shift models
- Base load

#### Evaluation of maxima

In the maxima representation (Fig. 14/11), the highest measured power values including the time stamp are entered in a descending order. Two reference lines are frequently drawn to mark a peak load reduction by 5% or 10% respectively. A maxima power view clearly shows in how many 15-minute intervals a load management system should have intervened and with which power reductions in order not to exceed a defined peak value. Variants of the maxima view map a daytime-specific distribution of load peaks, or show monthly maxima to enable the identification of leverage for load management improvements or an altered plant management.

### 14.4 Characteristic Values

The point of characteristic values is to provide an overview and enable comparisons to be made. Typical characteristics are analysed as monthly or yearly-related summation, maximum, mean, and/or minimum values. They can act as a leverage for energy management, since they illustrate, for instance, the spread of time-dependent power demands. Characteristic variables are:

- Energy (important for the kilowatt per hour rate)
- Power peak value (important for the demand charge)
- Usage period (important for prices)

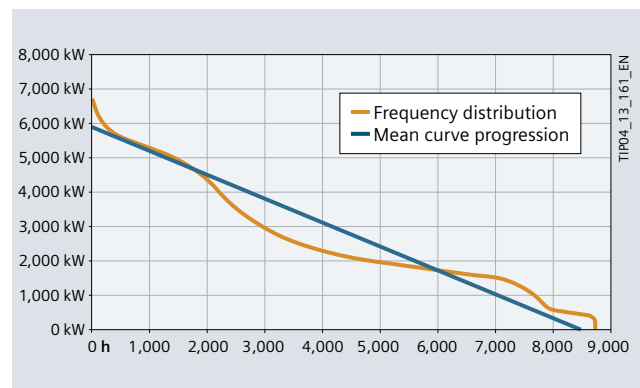

Fig. 14/10: Frequency distribution over one year and mean curve progression



- Full load hours
- Simultaneity factor
- Unit-specific energy values, e.g. work-shift values, item-based values, time-specific energy values
- Maximum, mean, and minimum values of current, voltage, power factor, power, and energy etc.

*Note: These kinds of directly indicated characteristic values can be the basis for further analyses which may be utilised to characterise buildings (energy per usable area, energy demand related to the cooling demand, ambience-specific dependency of extreme values, etc.) For more detailed information on characteristic values, data analyses and interpretations, please refer to [20].*

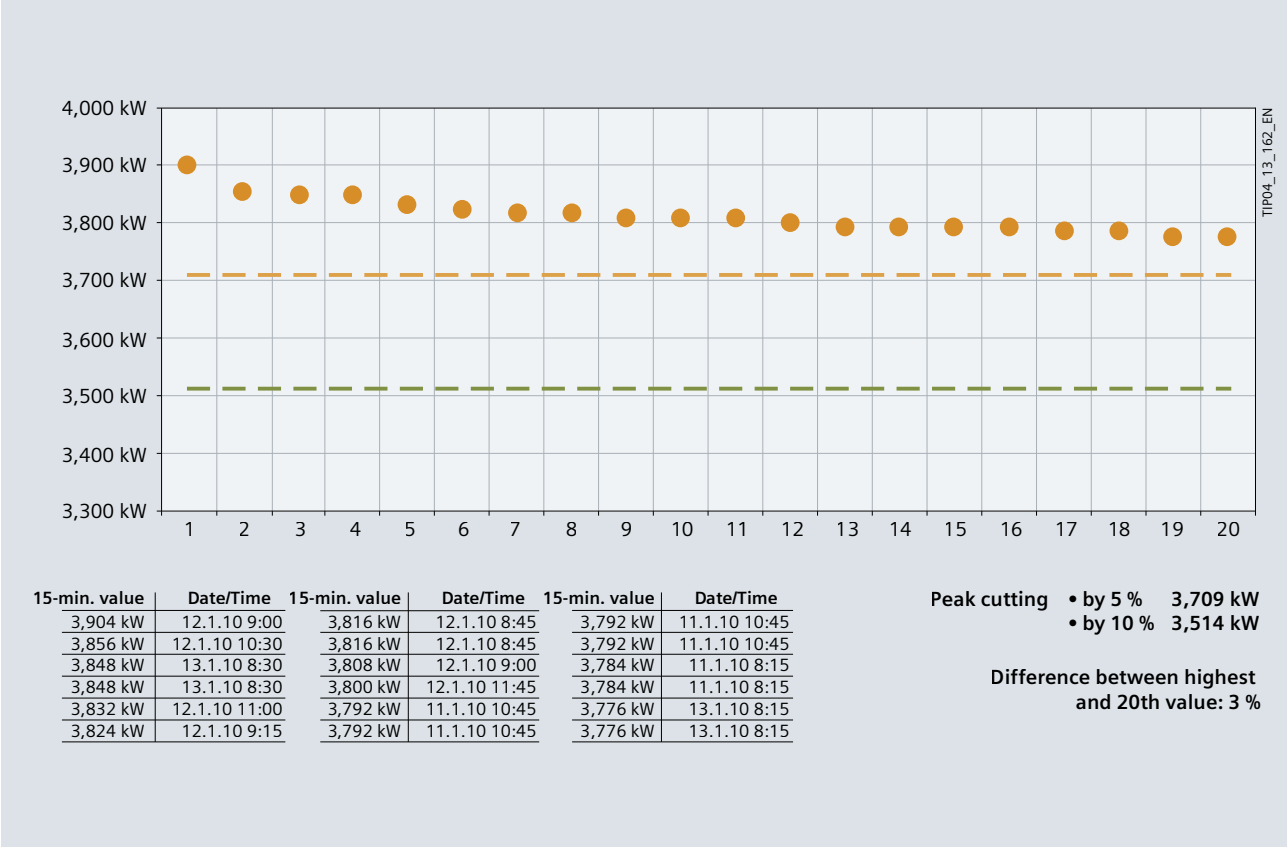

Fig. 14/11: Maxima view as a ranking of peak load values

[back to page 284](#)

### 14.5 Electricity Market Observations

Alongside safety and availability, a further main planning criterion rests with efficiency of the electrical power distribution. The framework is provided by the electricity market complete with supply/consumption control. Firstly to be presented are those factors influencing the electricity price to be followed by the general setting affecting both the smart grid and the liberalised energy market.

#### 14.5.1 Price of Electricity

The price of electricity is composed of the energy charge, the demand charge, taxes, and duties: The part related to the energy consumption is owed to the power supplier for the amount of electrical energy supplied. It is the product of power consumption in kWh and the energy charge in cent/kWh. The part related to the maximum power demand is owed to the distribution system operator for providing the infrastructure. It is the product of the highest 15-minute-interval purchased power in kW or the average of n x 15-minute-interval purchased power values in kW

(n is an agreed number of maximum values) and the demand charge in €/kW. Taxes and duties are to be paid to the national government. These taxes include the value-added tax, eco tax, a duty on renewable energies and, if applicable, one for combined heat and power generation. The concession fee is raised for usage of the public sphere and benefits the local authorities. Taxes and duties are calculated as a percentage of the energy charge and demand charge.

Internally, the price of electricity is normally calculated from the energy charge and demand charge only. Taxes and duties are not considered. The ongoing price of electricity in €/kWh is usually updated in the contractually stipulated raster. The average electricity price (AEP) is calculated from the sum of energy charge and demand charge divided by the quantity of electricity supplied:

$$\text{AEP in Cent/kWh} = \frac{(\text{energy charge in €} + \text{demand charge in €})}{\text{Quantity of electricity in kWh}}$$

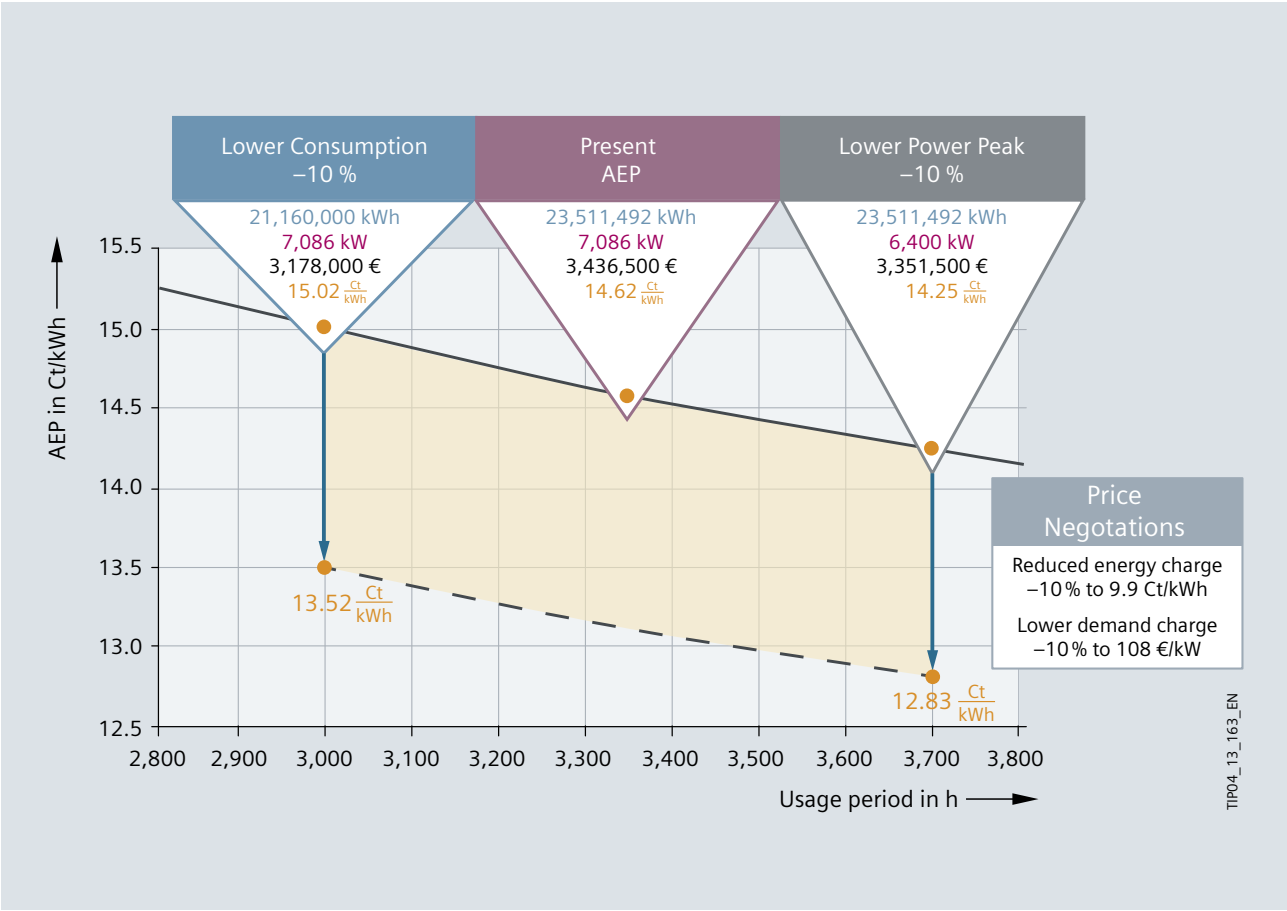

Fig. 14/12: Example of an "optimisation window" for the average price of electricity

[back to page 287](#)

The development of the electricity price as a function of the usage period can be graphically represented. The different options for optimisation as a result of energy charge and demand charge variations as well as specific time limits can thus be illustrated.

Shown in Fig. 14/12 on the X-axis is the usage period as a quotient from kW/h consumed per year and maximum 15-minute purchased power within the year and on the Y-axis the AEP. In so doing, the following key points are definable:

- Current AEP
- Possible energy savings while maintaining the maximum power purchase
- Possible saving of purchased power while keeping to the same amount of energy consumption
- Possible revised kilowatt-per-hour rate
- Possible revised demand charge

The assumption for the dashed curve in the view is a price reduction of energy charge and demand charge of 10% each. In the three tabs above the "optimisation window", the demand charge (120 €/kW) and energy charge (11 cent/kWh) are fixed prices. Variations of the consumption or required power peak result in changes to the usage period and AEP respectively. Please note that it is not the absolute cost of electricity that can be read from the "optimisation window" but a mean electricity price per kilowatt-hour consumed.

Depending on the supply situation on the part of the power supplier and grid operator, the variation of consumption and power peak can result in different starting positions for price negotiations. Of course, other characteristic parameters, distributions, and evaluations may also have an influence here.

### 14.5.2 Smart Grid

The term "Smart Grid" describes the intelligent interplay of power generation, storage, distribution, and consumption as an energy and cost-efficient overall system (Fig. 14/13). In a distributed and differentiated energy system, power generation and consumption must be balanced to the extent that today's quality standards (EN 60150) retain their validity. For the smart grid, grid modernisation and optimisation mainly affecting the distribution networks are very much to the fore. The following requirements placed on their operators impact on the interface between smart grid and consumer.

Today's still usual flow of energy from large power station to consumer by way of the transmission and distribution grids is increasingly being replaced by a distributed power

generation in small units within the distribution grid. The flow of energy may even be reversed with it being fed from the distribution grid into the transmission grid. In Germany, 97% of the regenerative energy generated in a distributed fashion was fed into the distribution grids at the end of 2012. The capacity installed was 83 GW. The capacity generated in a distributed fashion is likely to rise substantially as the energy turnaround gathers pace.

Within the smart grid, consideration is being given to directly controlling consumer equipment and guiding consumer attitudes by applying special tariffs so as to match consumption to power generation. a considerable planning outlay is required for generating power in a host of small to medium-sized plants, most of which are supplied from regenerative energy sources. The vital regenerative power generators are weather-dependent (PV systems from solar radiation which, in turn, is conditional upon locality and time, wind turbines from wind conditions dependent on locality and time). No generating forecasts are possible here without a detailed weather forecast. In addition, one needs to have forecasts of the consumption of the many electricity customers within the distribution grid. Without them, a balance between generation and consumption is impossible. What is absolutely needed is effective communication between the parties involved.

- Load and storage management  
To ensure maximum grid stability, the need is to use specialised load management solutions to reduce or shift load peaks. Good load management not only undertakes switching (switching loads on and off) but also plans shifting loads into other time windows. That is also the reason why increasing importance is attached to using distributed storage solutions. Storage management is concerned with specific loading and discharging of the storage cell based on a forecast which complies with both demand and actual generation. This entails having a broad information base and – as always with forecasts – some uncertainties still remain when cost considerations rule out the storage solution being as large as possible
- Automatic outage avoidance and restoring the supply  
Intelligent networking enables real-time monitoring and automatic system control to come from smart grids. Protection relays, fuses, and sensor systems forecast overloading and automatically switch off components before any damage has a chance to occur

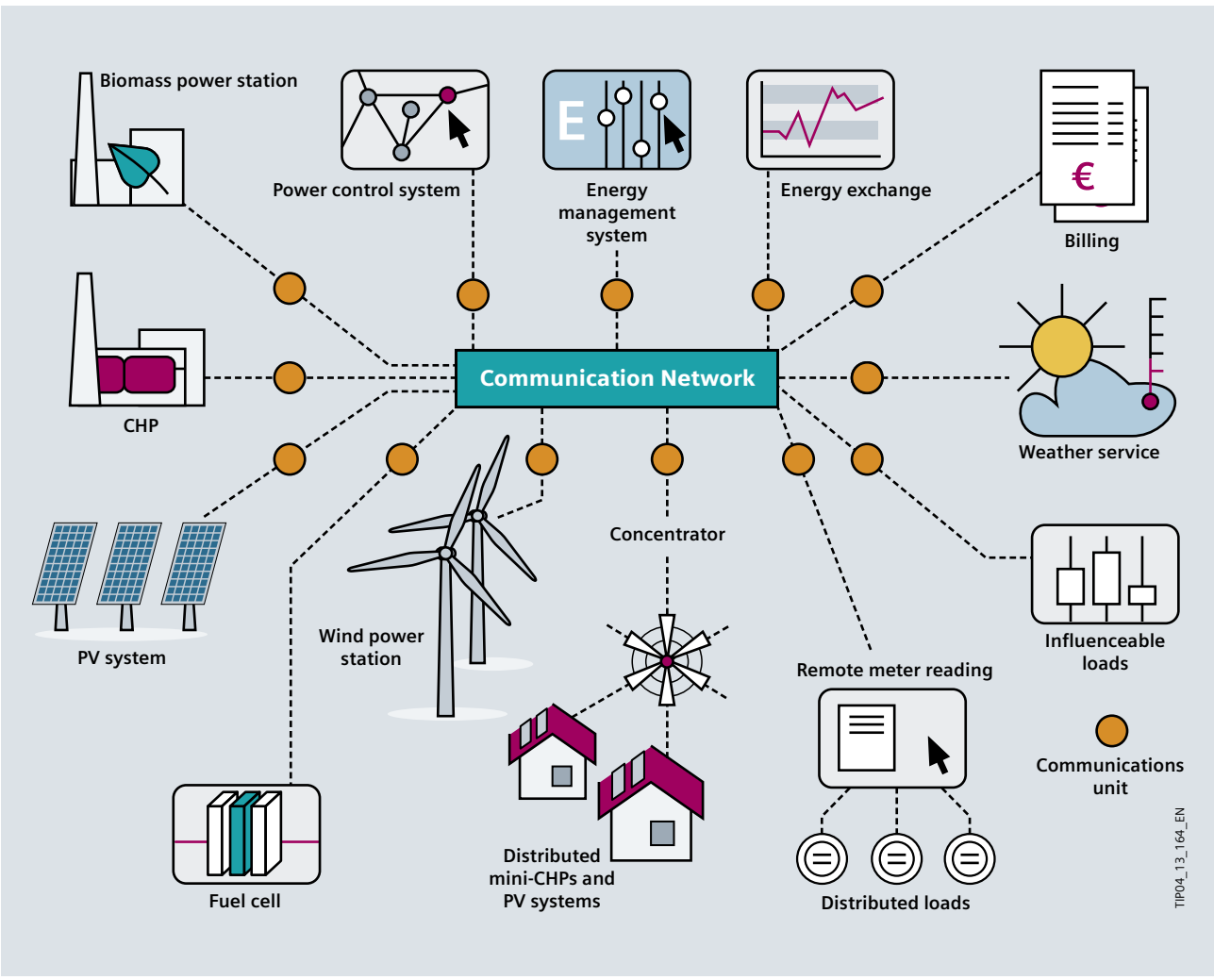

Fig. 14/13: Energy management in the smart grid through communication effected across all energy networks back to page 287

### 14.5.3 Liberalised Power Market

Liberalisation of the power markets leads to unrestricted trading in electricity involving vigorous competition. It began with the separation of generation, distribution, and sales. An electricity exchange has been established for electricity to be traded in line with market requirements. Liberalisation splits up the electricity market into a physical and commercial component (Fig. 14/14). The point of liberalisation was to improve transparency and create competitive incentives for those participating on the electricity market:

- Power generators  
The power stations of power generators produce the electricity which is fed into the transmission grid. Distributed power generation involves the electricity being generated near to consumers in, for instance, combined heat and power stations, industrial power plants, biomass plants, and distributed wind turbines and solar power plants

- Transmission grid  
Transmission grids represent national ultra-high voltage power grids (e.g. 220 kV, 380 kV) transferring large quantities of energy over considerable distances. The associated service companies running the transmission grid infrastructure are the transmission system operators (TSO). They ensure voltage and frequency stability under EN 50160 and, if necessary, must procure the control power needed for frequency and voltage control on the electricity market. These companies also ensure that the electricity traders/suppliers are in a position to direct the required quantities of electricity across the grids. On the basis of EC Directive 1228/2003/EC and electricity instruction 2003/54/EC, a description of the network and system regulations for Germany are given in the Transmission Code

- Distribution grid  
The distribution grid assumes the task of supplying the area at large with electricity. The electricity itself is either acquired from the transmission grid or from distributed power generators. Operation is the responsibility of the DSO. He is also responsible for metering (exception: the requirement in Germany is for the metering to be carried out by a metering operator). The DSO also sees that the energy quality in keeping with EN 50160 is upheld. He supplies the electricity to the consumers on the low- and medium-voltage level. The assignments and obligations of the DSOs in Germany are saved in the Distribution Code

- Metering operator  
The metering operator operates the metering equipment between DSO and consumers. He ensures that the metering point operates properly and provides the readings to both consumer and DSO. An obligation came into being in Germany in 2010 for smart meters to be fitted in all new buildings and for modernisations. The consumer is free to choose his/her metering operator

- Electricity exchange  
The EEX (European Energy Exchange) a market place for energy and energy-related products. It arose from merging the Frankfurt and Leipzig electricity exchanges and is based in Leipzig – with offices in Brussels, London and Paris. Traders from 22 countries currently participate in the exchange. As a public institution, the EEX is subject to German stock exchange legislation. Trading is done in spot and futures market products, such as base and peak. a distinction is made between day-ahead and continuously possible intraday auctions on the spot market for Germany/Austria, France and Switzerland. On the day-ahead market, hour and unit bids are traded for the following day, whilst on the intraday market this relates to individual hours (individual contracts) for delivery up to 45 minutes before its start

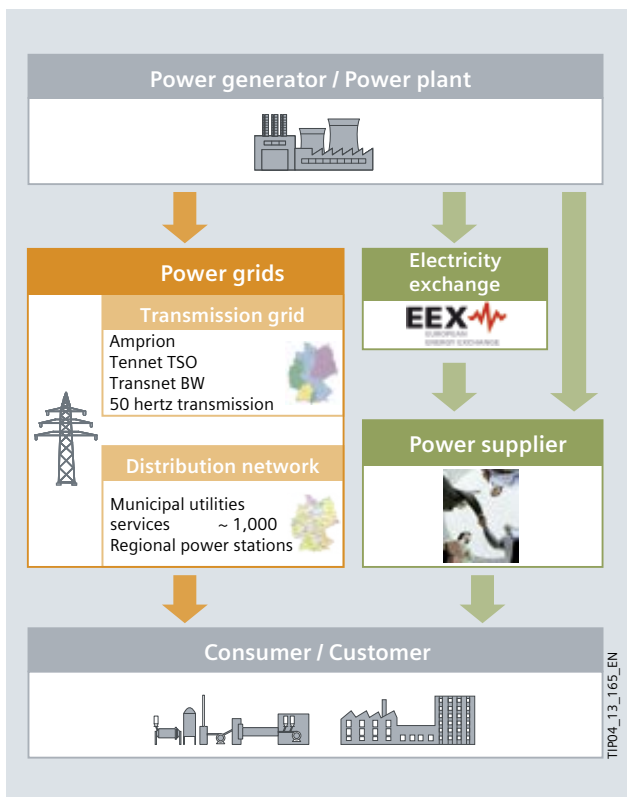

Fig. 14/14: Energy market structure in Germany representing that for the EU

- Electricity traders  
Only authorized traders are allowed to operate at the exchange. They implement the orders of the power suppliers at the exchange
- Power supplier  
The power supplier is the bridge between power generators and electricity consumers. He forecasts his electricity demand and covers this directly with the power generators and the electricity exchange. The power supplier concludes electricity supplier contracts with his customers. a number of energy service contracts are also on offer which – along with the supply of electricity – incorporate contracts with the DSO (grid connection contract, grid utilisation contract)
- Consumer  
The consumer buys electrical energy in order to operate his applications. Commercially viewed, he concludes a contract with the power supplier; whereas the supply is physically undertaken by the DSO

Given that the power market – as with any other commercial market – exists from predicting supply and demand, increasing importance is attached to the forecasts for consumption demand/ power generation supply and to their adherence. The smart grid as the link of many low-capacity and large-scale power stations as well as the exchange is very much dependent on steadfast forecasts. Consumer forecasts can be monitored on-line if smart meters are introduced across the board. In this way, the costs which the power supplier has from any variations from the forecast can be directly allocated to the party having caused them. In view of the fact that no 100% forecast is possible by consumers and that variations from it result in additional costs, the need is for load management here for aligning actual consumption to the forecast.

By controlling and adjusting generators, storage, and loads within a 15-minute cycle, ongoing demand can be adjusted to the schedule:

- The consumer is part of the smart grid and has an interface to this grid. By presenting forecasts and keeping to them he will, in future, be able to significantly influence his costs
- In supplying the current, the power supplier still expects a forecast of the energy import every 15 minutes one week in advance. Cost is allocated on the basis of the energy schedule ordered by the consumer and multiplied by the negotiated energy charge

- The DSO provides the connection to the supply grid and expects a statement of the maximum power which he is to provide at the interface to the consumer. Cost is allocated on the basis of the negotiated demand charge multiplied by the highest 15-minute power value within the period under consideration (month or year). a controlling role will increasingly be assigned to the DSO in the smart grid as well as possibly the responsibility for its operation

In view of their growth, clarification is needed on the contribution of distributed power generators towards grid stability (e.g. providing reactive power and/or control power). The ever-increasing feed-in of power from volatile energy sources has both markedly raised the need for control power and, at the same time, negatively impacted the cost-effectiveness of its generation.

## 14.6 Operational Management

Technical operation management for a building uses the energy management system as a basis for its own planning. Under the power supply aspect, efficient monitoring of operations and energy consumption using status displays and signalling equipment must be planned in line with the envisaged building usage possibilities. Even at the building concept stage, the associated measuring and control systems for building automation are to be provided. They should provide the following functional layers:

- Acquisition of status and measurements; processing level for data acquisition
- Operator control and monitoring with visualisation, archiving, reports, control of switchgear, status monitoring/measuring points

The following reasons are strong arguments in favour of a technical operation management system:

- Quick and simple online overview of states and the power flow/consumption in the building (Fig. 14/15)
- Validity check of the recorded values, avoidance of reading errors
- Optimisation of the purchasing contracts adjusted to the individual consumption shares
- More precise specification and more efficient power consumption from exact knowledge of the demand profile
- Transparency of costs in the energy sector
- Benchmarking (comparison of orientation values)

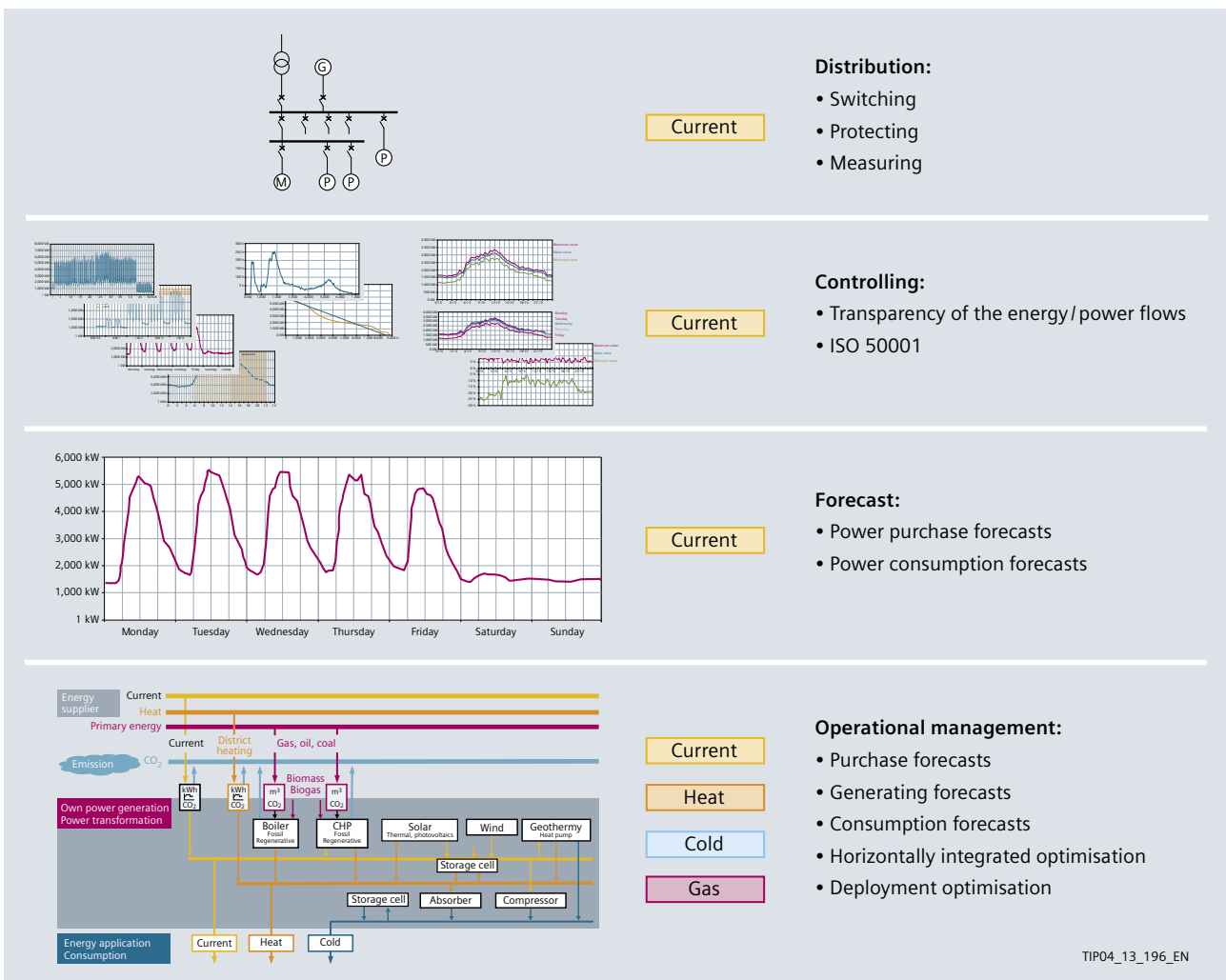

Fig. 14/15: Operational view of electric power distribution and incorporation into the operational management

## 14.7 Normative Basis for an Energy Management System

To remain commercially competitive, companies need to continually subject their competitive position and thus their energy consumption to critical examination and optimisation. A further incentive here comes from governments which increasingly have and want to ensure a cut in the greenhouse gas emissions of their country. The result is an increasing number of statutory regulations being decided on, which target emission reductions.

Playing an increasingly important role is energy consumption, as attested to by the stipulations of government and society concerning energy and the environment. Thus the necessity to optimise energy consumption entails considerable efforts on the part of the companies. They include:

- Reducing costs
- Strengthening company future prospects from clear-sighted consideration being given to rising energy costs
- Keeping to emission targets either imposed by governments or set down by the companies themselves
- Promoting sustainability of energy use and lessening dependence on fossil energy sources
- Improving the standing of the company on matters of responsibility within society

### 14.7.1 Definition Of Energy Management and Energy Management System

Energy management is accorded a vital task in lowering energy consumption. VDI Directive 4602 specifies energy management as that coordinating energy procurement, transformation, distribution, and application in a clear-sighted, organised and systematic fashion for the fulfilment of a task – with consideration given to both ecological and economic conditions. In ISO 50001, a definition is given of the Energy Management System (EnMS) as “all those associated, interacting elements for introducing an energy policy and strategic energy goals as well as processes and operations for attaining these strategic goals”.

Those countries propelling the introduction of a standard for energy management systems were China, Denmark, Ireland, Japan, South Korea, the Netherlands, Sweden, Thailand, and the USA. They drafted energy management standards, specifications, and provisions. This was followed by the European Standards Committee (CEN; fr: Comité Européen de Normalisation) publishing EN 16001:2009 Energy Management Systems – Requirements with Introduction as to Application as the first European Energy Management Standard. The standard published in July 2009 was replaced by international standard ISO 50001 in 2011. ISO 50001 also features the requirements placed on energy management systems and an introduction for their

application. In the standard, the term “organisation” is used generally to include undertakings, companies, and institutions. As early as 2008, the US Office for Standardizing Industrial Operations in conjunction with Brazilian associate ABNT was involved in developing ISO 50001:2011. Experts from over 40 countries were rendering assistance. Thanks to close cooperation with the European ISO member states, a lot of subjects and contents was transferred from predecessor standard EN 16001.

### 14.7.2 ISO 50001 Goals and Setup

The idea behind using the standard in setting up energy management systems and processes is to bring about a continuous improvement of energy-related performance and energy efficiency. This is to enable unused energy efficiency potentials to be used, CO<sub>2</sub> emissions to be permanently cut, and for energy savings to be realized. Furthermore, the current energy concept of the German government envisages an energy management system being the requirement for organisations to obtain tax concessions. The standard is to make employees and especially the management level of an organisation more receptive for comprehensive, long-term energy management. This approach allows saving potentials to be exhausted and competitive benefits and a marked image gain for the company to be obtained.

In view of the fact that ISO 50001 has a similar structure to that of other management standards (for example ISO 9001 and ISO 14001), an EnMS can easily be incorporated into other management systems – for instance for quality management. Also possible is separate examination of energy management in the company. This is why an EnMS can be introduced by organisations of whatever type and size. The standard is drafted irrespective of the energy type so that consideration can be given in the EnMS to all energy types such as electricity, cold, heat and the related coal, oil, and gas primary energy sources or the regenerative energy sources. Implementation of ISO 50001 requirements can be certificated by specific institutes and organisations. Recurrent audits then endorse this certification. However, at the moment there is a considerable lack of transparency and specific knowledge as to how energy flows and how energy flow can be sub-divided. Comparative values are also frequently missing, on which quantifiable statements can be derived and on whose basis decisions can then be made. By introducing an EnMS, organisations make it clear that by continuing an improvement process involving a sustainable use of energy they wish to bring about a cut in energy consumption. An EnMS has been a requirement since 2013 for energy-intensive organisations wanting to benefit from tax concessions.



### 14.7.3 Management Process

ISO 50001 describes a continuous improvement process for a more efficient use, monitoring and analysis of energy. The principal setup follows the PDCA cycle as applied, for instance, to the ISO 9001 standard and which is to be adapted to the daily operation of an organisation: Plan, Do, Check, Act. Proceeding on the basis of this cycle, a model for the EnMS is described (Fig. 14/16) followed by specification of the requirements. In particular, the responsibility of the manager of an organisation is gone into.

The energy policy specifies the energy framework and establishes the strategic goals to be aspired to by the organisation regarding energy utilisation. a description is also given of the communication on this and the reaction to be expected of those employed in the organisation. The obvious goal of the energy policy must be towards continuously improving energy handling.

The energy plan describes the energy deployment analysis, establishment of relevant determinants and influencing scope for energy utilisation, energy policy implementation in enhancement operations and verification of operative goals attainment. Explicitly, the need is for an energy measurement plan to be laid down and implemented. Campaign plans to enhance the energetic performance of the organisation need to be introduced and implemented. Under a bi-directional communication process, appropriate

aids, training courses and information are to be provided. A documentation on the key EnMS elements and their interaction must be present. Controlling documents and processes is oriented to the corresponding specifications for other management processes, such as that of quality or environment management, and needs to conform to management standards.

Demanded by ISO 50001 is the monitoring, testing and analysis of the main energy-relevant operations of an organisation at scheduled intervals. The improvement of energy-related performance needs to be taken into account when designing new, modified or renovated buildings, systems, plants, facilities, and processes. This also applies to energy metering and the attendant scope for evaluation and analysis.

A supplier assessment can be carried out when purchasing energy and energy services as well as products and facilities to enhance the energy-related performance of an organisation. Possible criteria here are, for instance, energy quality, cost structure, environmental impact, and deployment of renewables. Those suppliers taking part need to be informed about the assessment and the criteria.

An EnMS includes self-appraisal as to adherence to statutory regulations and execution of internal audits at scheduled intervals. Both need to be documented and a report drafted for senior management. Any variations and

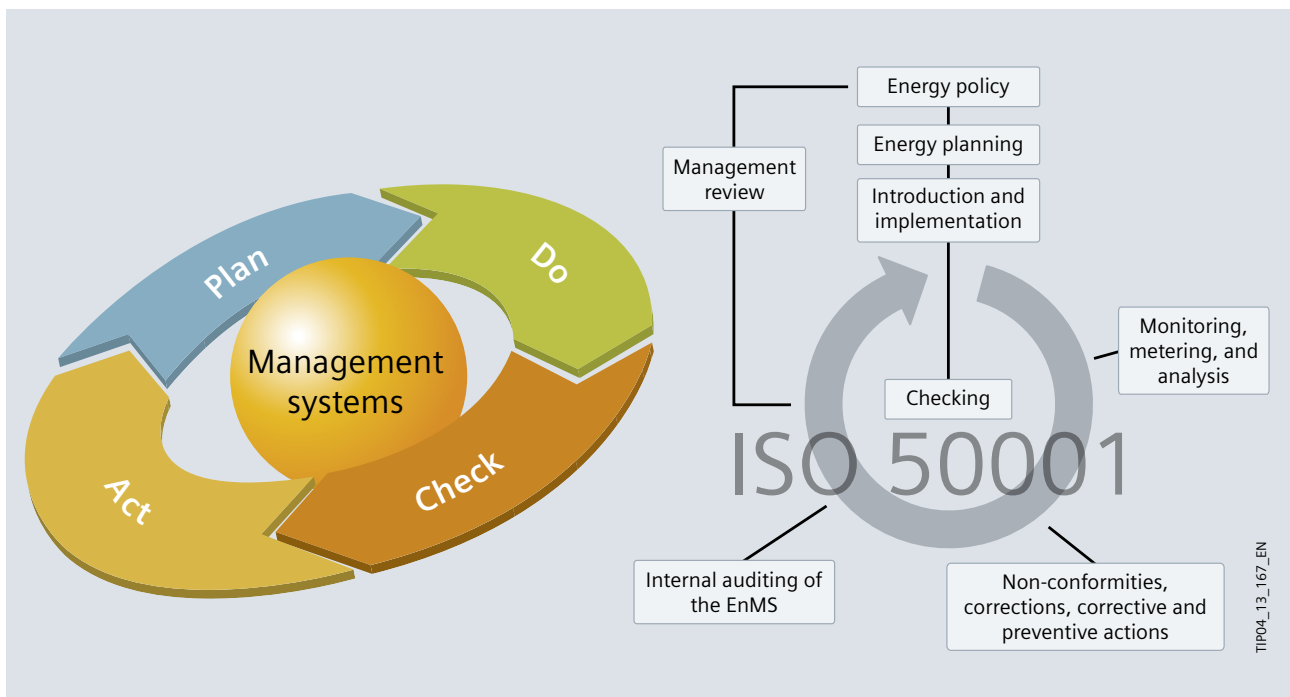

Fig. 14/16: Implementation of the PDCA management cycle for EnMS in ISO 50001

1 nob-conformities are to be recorded. Corrective and preventive measures are to be defined and examined as to effectiveness. It is the responsibility of senior management to check on the EnMS at defined intervals and document the findings.

2  
3 Planning, realisation, and implementation of measures to enhance the energetic performance will involve the electrical designer increasingly looking into consultancy services. To this end, formulating operative goals is only appropriate if they can be attained through activities which benefit the organisation. By means of a system overview involving knowledge of dependencies between appliances, installations, and systems and equally from ongoing market knowledge, a consultant can then distinguish between what is feasible from half-truths and one-sided benefit considerations and also present his customers with cost-effective solutions. For instance, metering the power consumption of a pump given proper metering interpretation provides the same information as a significantly more expensive flow meter. a solution with the right instruments and data transfer opportunities at the decisive points (see Fig. 14/2) can keep the costs in check and be especially appropriate for a future extension.

4  
5  
6  
7  
8  
9 Consultancy services of organisational relevance could, for instance, refer to preparing and depicting measurement data as described above in sections 14.2 to 14.4. They form the basis for an analysis leading to an even clearer case of transparency. This analysis can also become part of the consultant's work. To this end, the Siemens TIP Consultant Support Promoters provide assistance for electrical designers.

10  
11 *siemens.com/tip-cs/contact*

A man in a light blue shirt is shown in profile, looking at a computer monitor. The monitor displays a complex network diagram with various nodes and connections. The man's hand is resting on his chin, suggesting a thoughtful or analytical state. The background is slightly blurred, showing what appears to be a server room or a control center with racks of equipment.

# Chapter 15

## **SIMARIS Planning Tools for the Efficient Planning of Power Distribution**

15.1	Dimensioning with SIMARIS design	297
15.2	Determining Space Requirements with SIMARIS project	298
15.3	Displaying Characteristic Curves with SIMARIS curves	299
15.4	Tool Efficiency	299

# 15 SIMARIS Planning Tools for the Efficient Planning of Power Distribution

- 1
- 2
- 3
- 4
- 5
- 6
- 7
- 8
- 9
- 10
- 11
- 12
- 13
- 14
- 15
- 16
- 17

Since the requirements for the equipment of non-residential and industrial buildings as well as the expectations with regard to system safety and documentation are steadily increasing, the planning of electric power distribution becomes more and more demanding and complex. The SIMARIS planning tools support you in planning power distribution systems in buildings and allow for convenient and easy operation thanks to well designed user interfaces and functions which can be used intuitively. To help you familiarise and work with the SIMARIS planning tools, tutorials, help files, and a Technical Manual are integrated in the programs. These aids can also be directly downloaded at

[siemens.com/simaris/help](http://siemens.com/simaris/help)

In addition, the SIMARIS planning tools are available in many languages and numerous country-specific product portfolios, so that you can also plan projects for foreign countries without difficulties. A reference list (for countries and languages) can be found at

[siemens.com/simaris/faq](http://siemens.com/simaris/faq)

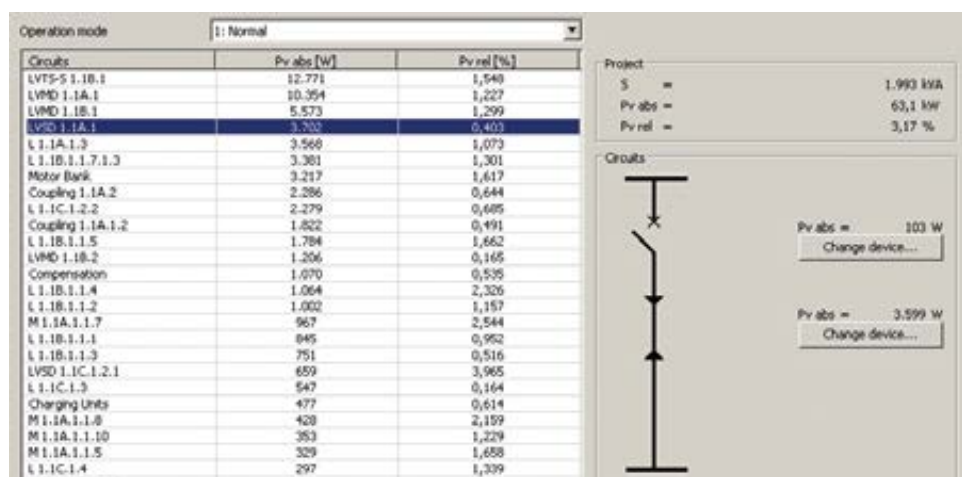

Fig. 15/1: Power losses of the network configured with SIMARIS design professional

[back to page 297](#)

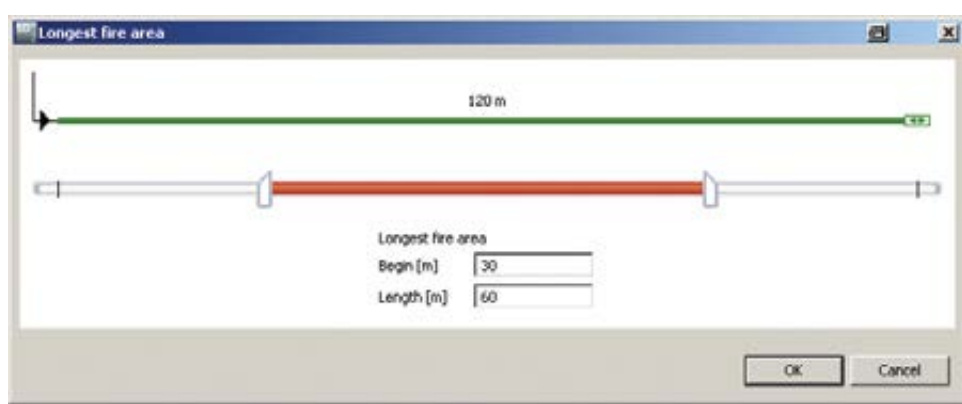

Fig. 15/2: Defining the longest fire section for a busbar trunking system in SIMARIS design

[back to page 297](#)

## 15.1 Dimensioning with SIMARIS design

Based on specifications resulting from the project requirements, SIMARIS design can be used to dimension the equipment according to the accepted rules of good installation practice and all applicable standards (VDE, IEC), from medium-voltage supply to the power consumers. SIMARIS design supports the calculation of short-circuit currents, load flow and distribution, voltage drop, and energy report. Moreover, SIMARIS design assists in the selection of actually required equipment, for example medium-voltage switching and protection devices, transformers, generators, low-voltage switching and protection devices, and in conductor sizing, meaning the sizing of cables, wires, and busbar trunking systems. In addition, the lightning and overvoltage protection can be included in the dimensioning process. The “professional” version of SIMARIS design also allows determining the power losses of equipment during network calculations. To this end, an overview is created in SIMARIS which shows where the greatest losses occur in the network. Suitable adjustments in equipment selection then allow reducing such power losses, thus the energy efficiency of the network can be optimised (Fig. 15/1). The power supply system to be planned can be designed graphically in a quick, easy, and clear way with the help of the elements stored in the library.

If functional endurance is to be considered in the network calculation, the relevant data can be specified in SIMARIS design in order to include this requirement in the dimensioning process. The longest fire section relevant for calculation can very easily be defined when the network configuration is created. For example, a slider can be set for busbar systems, or the start and end point of the longest fire section within this busbar line can be entered (Fig. 15/2).

Prior to dimensioning, the electrical designer defines the operating modes required for the project. This definition can be more or less complex, depending on the project size and the type and amount of system infeeds and couplings used. However, with SIMARIS design this definition is quite simple, since the relevant devices and their switching conditions required for the respective operating modes are presented graphically in a clear and well structured manner. All common switching modes can be mapped and calculated thanks to the option of representing directional and non-directional couplings and infeeds at the sub-distribution level and isolated networks. Sizing of the complete network or subnetworks is done automatically according to the dimensioning target of “selectivity” or “backup protection” and the calculation results can be documented with various output options. With the “professional” version of the software, it is possible, among other things, to perform a selectivity evaluation of the complete network.

From experience, planning an electric power distribution system is always subject to considerable changes and adaptations both in the planning and in the implementation stage, for example also due to concept changes on part of the customer forwarded at short notice. With the help of the software, adaptations of the voltage level, load capacities, or the technical settings for medium or low voltage can be quickly and reliably worked into the supply concept, for example; this includes an automatic check for permissibility in accordance with the applicable standards integrated in the software (Fig. 15/3).

An overview of the features integrated in SIMARIS design as well as the additional functionality of the paid version “SIMARIS design professional” is available at

[siemens.com/simarisdgdesign](http://siemens.com/simarisdgdesign)

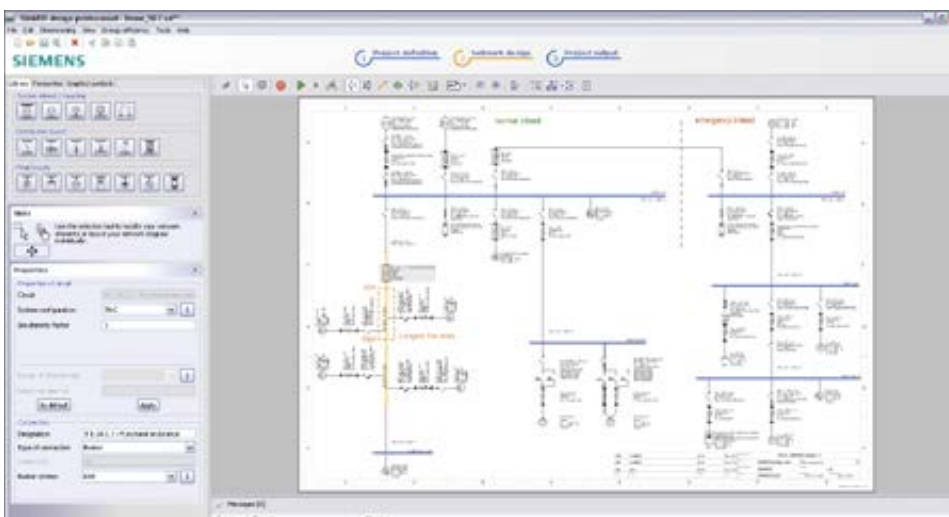

Fig. 15/3: Network design with SIMARIS design

## 15.2 Determining Space Requirements with SIMARIS project

After network calculation was completed in SIMARIS design professional, an export file can be generated which contains all the relevant information on the established equipment. This file can be imported in SIMARIS project for further editing within the scope of the planning process. Here, the established devices and other equipment can be allocated to the concrete systems. Thus, the space requirements of the planned systems can be determined and the budget be estimated. If an export file from SIMARIS design is not available, the electrical designer can determine the required medium-voltage switchgear, transformers, busbar systems and devices for the low-voltage switchboards and distribution boards directly in SIMARIS project on the basis of the given technical data and defined project structure. An overview of the functionality integrated in SIMARIS project can be obtained from

[siemens.com/simariproject](http://siemens.com/simariproject)

Depending on the type of system, the systems are represented graphically or in list form. For example, the electrical designer can directly select and graphically place the panels required for the medium-voltage switchgear, whereas selected transformers and the components required for the busbar trunking systems are presented in list form. It is also possible to factor in the functional endurance of busbar trunking systems, especially for power

transmission, if required. In accordance with the respective functional endurance class and the specification whether 2-, 3- or 4-sides with Promat® are desired, the quantity and thickness of the Promat plates required to attain functional endurance are calculated automatically.

In SIMARIS project, the devices required for low-voltage switchboards and distribution boards are first compiled in a list and then automatically placed in the cabinets / cubicles. The device arrangement created in this process can then be modified in the graphic view. In addition, a purely graphical plant design is offered for the low-voltage switchboards. To this end, cubicles and devices with the matching assembly kits can be selected from the library contained in SIMARIS project and graphically placed with drag and drop actions.

In the further course of the project, the planning can be continually adapted to current requirements, becoming ever more detailed as the project proceeds. The user gets concrete technical data as well as dimensions and weights for all components in the power distribution system. For the documentation of the planned systems, SIMARIS project also allows the creation of view drawings, technical descriptions, component lists and even tender specifications (BOQ, bill of quantities). The budget for the planned systems can either be obtained by sending the project file to the responsible Siemens contact or, you can perform the calculation yourself. To support your own calculation, a list of the configured systems is created in SIMARIS project as a summary, in which every system can be assigned a price as well as additions and reductions (Fig. 15/4).

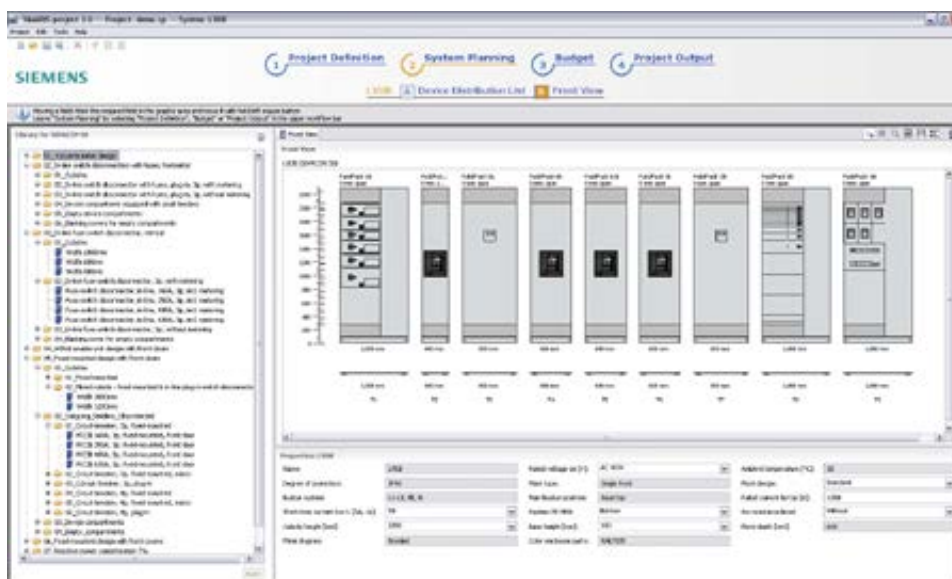

Fig. 15/4: System planning with SIMARIS project

### 15.3 Displaying Characteristic Curves with SIMARIS curves

If detailed information on the tripping performance of individual devices is required for planning preparations or for documentation purposes, SIMARIS curves can be used to visualise and assess tripping curves and their tolerance ranges. The curves can be adapted by simulating parameter settings. Moreover, SIMARIS curves can also be used to display and document cut-off current and let-through energy curves for the devices (Fig. 15/5). A selectivity evaluation is not implemented. It must be carried out in SIMARIS design.

An overview of the functionality integrated in SIMARIS curves can be obtained from

[siemens.com/simariscurves](http://siemens.com/simariscurves)

### 15.4 Tool Efficiency

Frequently required modules, devices and systems can be saved as favourites and integrated in later planning files again. The planning expense can thus be further reduced by using the SIMARIS planning tools. Online updates enable the user to update saved product data in an uncomplicated way. The specifications are, of course, synchronised between the programs.

Link to the topic

[siemens.com/simaris](http://siemens.com/simaris)

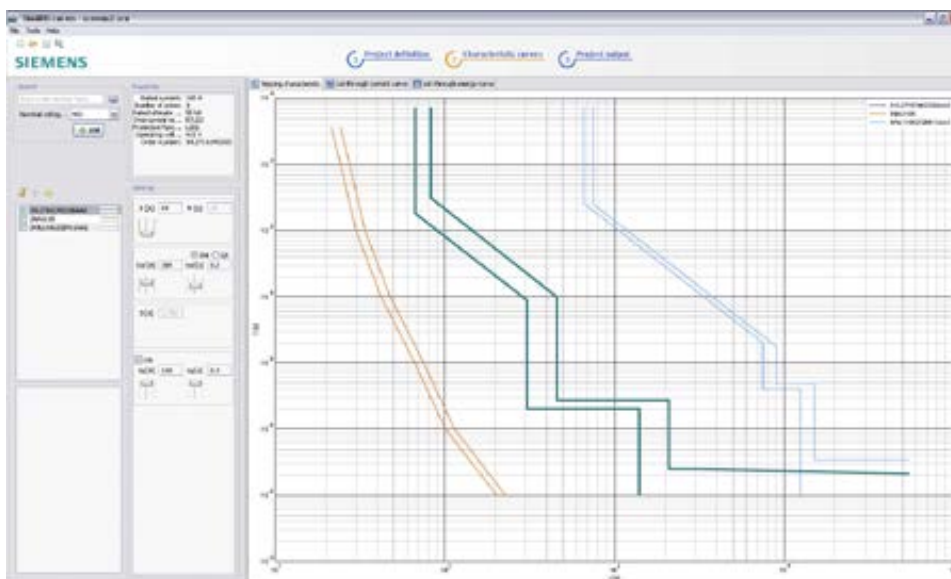

Fig. 15/5: Characteristic curves (fuse, moulded-case circuit-breaker, air circuit-breaker) in SIMARIS curves

Con-  
tents

Intro-  
duction

1

2

3

4

5

6

7

8

9

10

11

12

13

14

**15**

16

17





# Chapter 16

## Lighting Inside Buildings

16.1 Basic Data Establishment	302
16.2 Building Analysis	305
16.3 Normative Specifications	305
16.4 Lighting Scheme	312
16.5 Lighting Calculation	318
16.6 Emergency Lighting	329

# 16 Lighting Inside Buildings

1

People stay in buildings and perform various activities there. Visual perception is the most frequently used human sensory impression inside buildings. Therefore, specific lighting is required which reflects the correlations between architecture, daylight, visual task, biological effect, energy efficiency, illuminant, and luminaire in buildings. In the end, light is the form of energy that brings together people and building including the equipment. The planner faces a versatile organisational task that goes far beyond considering lighting merely as part of the architecture.

2

3

4

5

## 16.1 Basic Data Establishment

6

The basic requirement for a good lighting solution is the compilation of constructional and technical conditions and a founded establishment of all parameters against which the lighting is pitted. Therefore, no lighting task equals another and each one is a new challenge. The procedure should be selected appropriately and includes the basic data establishment as the first planning step:

7

8

9

10

11

12

13

- Clarification of the task with the client and important electrical planning engineers involved
- Clarification of the user's needs and requirements as to the use and room function (wishes, assessment criteria, experiences, standards)
- Consideration of the operating conditions (dust, humidity)
- Establishment of the structural conditions (building and building grid, room geometry)
- Consideration of the building's macrostructure (technical development, lifts, staircase, office levels)
- Consideration of façade views and surroundings (daylight factor)
- Determination of the value and quality standards of the building (degree of automation and value of the illuminants and luminaires)
- Efficiency of the energy use (optimisation through suitable illuminants and luminaires and their positioning as well as through matched automation)

14

Therefore, technical and architectural factors as well as purely subjective influences such as light colour, brightness distribution, time- and calendar-dependent brightness course and the users' vision need to be considered in the planning phase. For the economic aspect of lighting, the lamps and luminaires as well as the use of light energy and an energy-efficient transformation of electric current into light have to be minded.

15

16

17

The basis of planning is the synchronisation with the users' requirements profile and the architectural requirements. As a reference for interior rooms, EN 12464-1 specifies rated

illuminances. Numerous brochures state typical characteristic values that refer specifically to this standard.

The data for the illuminance maintenance value ( $\overline{E}_m$ ), the maximum unified glare rating limit value ( $UGR_L$ ) for discomfort glare assessment, the minimum uniformity ratio of illuminance ( $U_0$ ) and the minimum value of the colour rendering index ( $R_a$ ) should be agreed with the client. In view of an increasing consideration of the biological effect of light, these parameters have to be regarded more intensely in the planning phase.

For the purpose of integrated planning, the electrical designer should know the basic task of lighting designers and architects and be able to synchronise with them. Therefore, crucial points in the creation of a lighting scheme will be dealt with in the following (see Fig. 16/1). First of all, the prerequisites for the normative clarifications are created within the scope of a building analysis. Then, the lighting scheme is created and the lighting calculations are made.

To find optimal lighting solutions, interdependencies between lighting and work task, workflows, working appliances and tools, furnishing, workplace layout, interior and building design have to be considered (see Fig. 16/2). This becomes noticeable in energy and economic efficiency as well as in "soft" factors such as orientation, well-being and naturalness.

- 16.1 Basic data establishment**
- Creation of the users' requirements specification
  - Creation of the architect's requirements specification

- 16.2 Building analysis**
- Project analysis
  - Zoning in detail
  - First technology concept for technical building equipment is available (control system, bus systems etc.)
  - Façade details are known (daylight factor)
  - Ceiling system is known

**16.3 Normative specifications**

Lighting of workplaces	Energy efficiency	Biological effect
European level EN 12464-1  Germany DIN 5035-7/-8 ASR A3.4	European level Directive 2012/27/EU, Directive 2010/31/EU (2006/32/EC, 2002/91/EC)  Germany EnEV 2014 / DIN V 18599-1, -4, -10	Germany DIN Spec 67600 (see also VDI 6008 Sheet 1 and Sheet 3)

- 16.4 Lighting scheme**
- Design principles
  - Determination of the mounting position
  - Definition of the light distribution
  - Consideration of daylight and lighting management
  - Determination of the illuminants
  - Selection of the luminaires

- 16.5 Lighting calculation**
- Calculation proof conforming to standards
  - Determination of the maintenance factor
  - Visualisation and documentation
  - 3D representation

TIP04\_13\_175\_EN

Fig. 16/1: Flow diagram for lighting planning

[back to page 302](#)

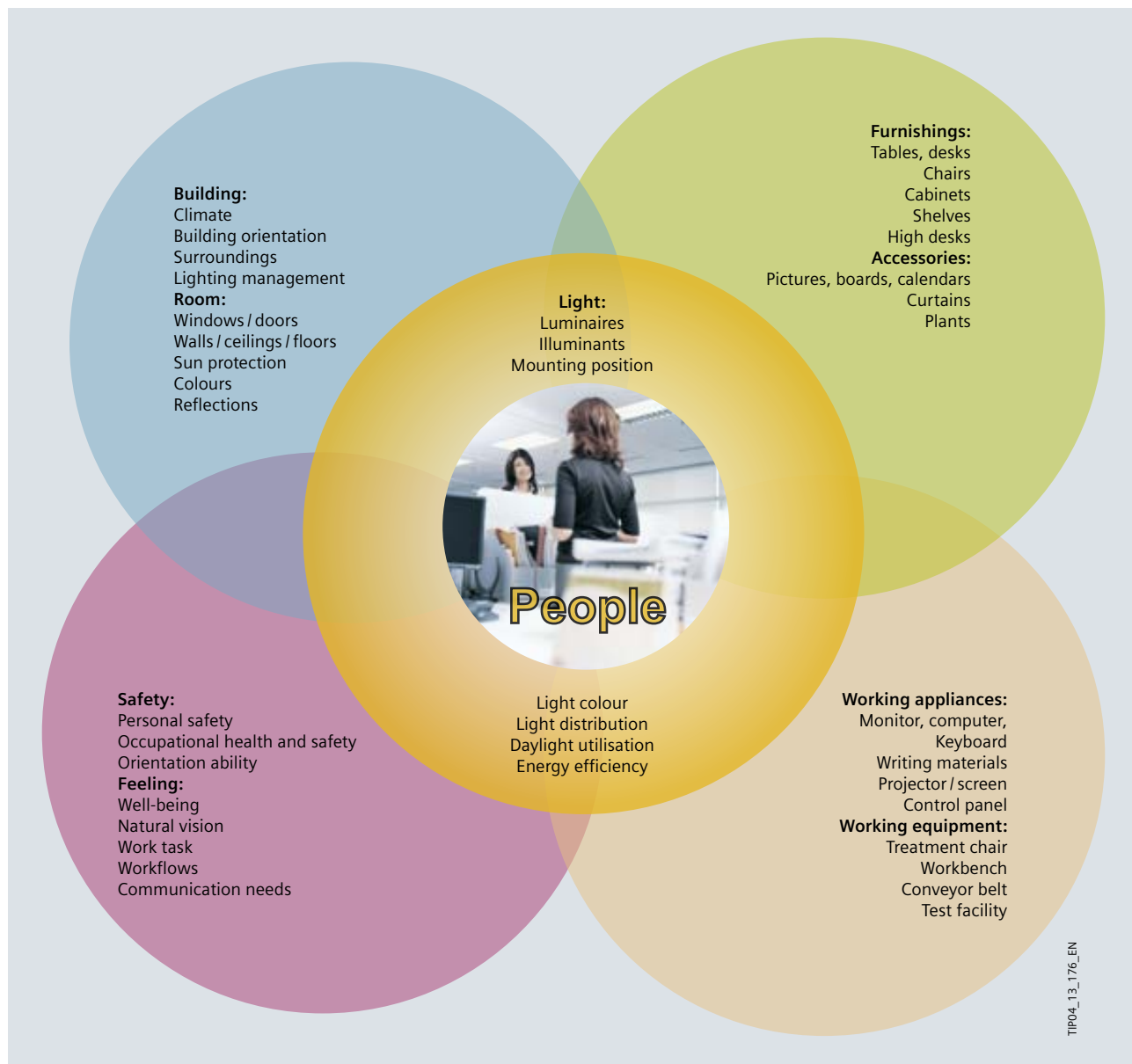

Fig. 16/2: Task fields in lighting planning

[back to page 302](#)

## 16.2 Building Analysis

The architectural surroundings and design of the building structure have a great influence on the lighting planning. After clarification of the basic specifications, a building analysis is conducted to emphasize the correlations. This analysis comprises the following:

- Analysis of the existing lighting system (if any) including the recording of positive and negative experiences
- Analysis of the determined basic information, the architecture, the client's wishes, and the users' requirements
- Analysis of the first plans (floor plans and sectional views)
- Zoning of floors, rooms and areas into traffic routes, workplaces, common zones etc.
- Analysis of an existing technology concept (control system, bus systems etc.)
- Recording of the technical requirements (the building control system to be considered, integration of further components outside the subject area, requirements for control systems, electrification options)
- Analysis of the ceiling system
- Analysis of the mounting options and restrictions (beams, recessed ceiling installations)
- Definition of possible mounting positions based on the structural conditions

## 16.3 Normative Specifications

Standards serve for rationalisation, quality assurance, protection of users and surroundings as well as for safety and communication. As for the lighting, a variety of aspects such as the biological effect of light, the energy input for the generation of light and the technical aspects of light distribution are important, various normative specifications have to be considered for the planning task. At this point, we refer to the numerous country- and trade-specific directives, regulations and ordinances that are to be complied with. Examples from Germany:

- ASR A3.4  
Technical workplace regulation on lighting systems
- BGI 650  
Information of the German Employer's Liability Insurance Association about monitor and office workplaces
- VDI 6011-1  
VDI guideline on the optimisation of daylighting and artificial lighting – Fundamentals

With regard to energy efficiency and ecological framework conditions for lighting, the EU directives form a framework that is to be implemented in the national legislation of the Member States of the European Union:

- Directive 2009/125/EC:  
establishing a framework for the setting of ecodesign

requirements for energy-related products (replaces Directive 2005/32/EC)

- Regulation 244/2009 of the European Commission (plus modifications in accordance with EU regulation 859/2009):  
implementing Directive 2005/32/EC to define ecodesign requirements for non-directional household lamps
- Regulation 245/2009 of the European Commission (plus modifications in accordance with EU regulation 347/2010):  
implementing Directive 2005/32/EC to define ecodesign requirements for fluorescent lamps without integrated ballast, for high intensity discharge lamps, and for ballasts and luminaires able to operate such lamps
- Regulation no. 1194/2012 of the European Commission: implementing Directive 2009/125/EC with regard to ecodesign requirements for directional lamps, light emitting diode lamps and related equipment
- Directive 2010/30/EU:  
on the indication by labelling and standard product information of the consumption of energy and other resources by energy-related products (replaces 92/75/EEC)
- Directive 2010/31/EU:  
on the energy performance of buildings (successor of Directive 2002/91/EC)
- Directive 2012/27/EU:  
on energy efficiency, amending Directives 2009/125/EC and 2010/30/EU and repealing Directives 2004/8/EC and 2006/32/EC

In Germany, the energy saving ordinance for buildings (EnEV 2014) serves for the transposition of Directives 2010/31/EU and 2012/27/EU for saving energy in buildings and thus for the definition of criteria for the energy efficiency of lighting. In addition to that, in Germany the "Energy Consumption Relevant Products Act" (Gesetz über die umweltgerechte Gestaltung energieverbrauchsrelevanter Produkte – EVPG) of 25 Nov. 2011 serves for the implementation of Directive 2009/125/EC. It is to contribute to the improvement of energy efficiency and eco-friendliness of the affected products.

As the electric power supply of buildings takes centre stage, the following overviews focus on relevant standards for the lighting of rooms inside buildings:

- EN 12665  
Light and lighting – Basic terms and criteria for specifying lighting requirements
- DIN 5035-7 and -8  
Artificial lighting due to the revision of EN 12464-1 of 2011, DIN 5035-7 is currently being revised
- EN 12464-1  
Lighting of indoor workplaces  
(in areas close to buildings such as residential streets,

parking sites and footways, lighting requirements in compliance with the applicable standards for the lighting of outdoor workplaces in accordance with EN 12464-2 or the standard series EN 13201 for road lighting are to be observed)

- EN 15193  
Energy performance of buildings – Energy requirements for lighting  
In the national annex for Germany, reference is made to the simpler calculation methods of the German pre-standard DIN V18599-4, which are to be used for the planning (EN 15193 is currently being revised due to the revision of Directive 2010/31/EU).
- Pre-standard DIN V18599-1, -4, -10  
Energy efficiency of buildings  
Part 1: General balancing procedures, terms and definitions, zoning and evaluation of energy sources  
Part 4: Net and final energy demand for lighting  
Part 10: Boundary conditions of use, climatic data
- DIN SPEC 67600  
Biologically effective illumination – Design guidelines

Based on the flow diagram depicted in Fig. 16/2, the normative bases with regard to technology, energy consumption and the biological effect of lighting inside buildings will be touched in the following.

### 16.3.1 Lighting of Indoor Workplaces – EN 12464-1

The normative specifications for the requirements imposed on the state of the art that have to be met at the minimum are described in EN 12464-1 on the European level. For the first time, uniform characteristic values apply for the specific requirements imposed on the lighting of different buildings, rooms and usages.

The standard on the lighting of indoor workplaces is regarded as a recommendation for the technical implementation of good lighting and does not impose any requirements on the lighting of workplaces with regard to the safety and health of the people working at the workplaces. In Germany, specific ordinances and associated guidelines apply to that, such as the Workplace Ordinance and ASR A3.4 or specifically for monitor and office workplaces BGI 650.

When planning lighting systems, the state of the art as described in EN 12464-1 is to be applied in consultation with the clients. It is reasonable, however, to mind the compliance with specific requirements (occupational safety and health, workplace-specific requirements such as for a display workstation etc.) already in the planning phase, as the data on illuminance or colour rendering index in section 5 of EN 12464-1 may differ for individual working

rooms, workplaces or activities from the data in ASR A3.4, for example.

EN 12464-1 identifies visual comfort, visual performance and security as basic human needs. The purpose of lighting is to influence these criteria with daylight and artificial lighting. The following lighting factors are considered:

- Luminance distribution
- Illuminance
- Spatial illumination
- Level and colour of light, through variability and rendering of light
- Interferences such as glare or flickering

The technical and ergonomic aspects of lighting are considered in EN 12464-1. There, a differentiation is made between the visual task area, the immediate surroundings, and the background (see Fig. 16/3).

The illuminance on the immediate surroundings depends on the illuminance on the visual task area. The maintenance value for the illuminance of the immediate surroundings may be lower, but it must not drop below certain levels (Tab. 16/1). For the background area, the illuminance must correspond to a maintenance value of 1/3 of the value for the immediate surroundings.

EN 12464-1 specifies the illuminances as maintenance values, that is, as minimum values that must not be undercut. The maintenance factor (MF) takes into account operational influences such as ageing and pollution. When these minimum values are reached, the lighting has to be maintained (Fig. 16/4). The planner must state the maintenance factor and assumptions for value determination,

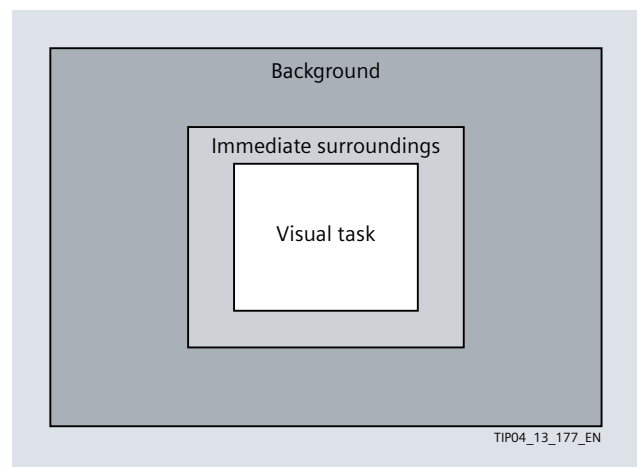

Fig. 16/3: The visual task area with immediate surroundings (strip of 0.5 m beyond the visual field) and background area (within the room limits at least 3 m wide)

Illuminance "visual task" in lx	Illuminance "immediate surroundings" in lx
≥ 750	500
500	300
300	200
≤ 200	= $E_{\text{visual task}}$

Tab. 16/1: Correlations between the illuminance levels

determine the lighting system dependent on the operating conditions, and attach a comprehensive maintenance plan. This maintenance plan should describe the cleaning and replacement of lamps and luminaires as well as the cleaning and modification of the rooms.

For the determination of the maintenance factor, EN 12464-1 refers to the international standard CIE 97-2005 (International Commission on Illumination, French: commission internationale d'éclairage). There, it is described as a product of single components:

$$MF = LLMF \cdot LSF \cdot LMF \cdot RSMF$$

where

- LLMF Lamp lumen maintenance factor
- LSF Lamp survival factor
- LMF Luminaire maintenance factor
- RSMF Room surface maintenance factor

Criteria influencing the MF:

- Use of lamps with lower or higher luminous flux collection (dependent on the burning time)
- Disposition to dust accumulation in luminaires
- Dust and smoke exposure of lamps and luminaires due to the room utilisation and environmental influences (may lead to discolouring/yellowing)

- Disposition of reflecting surfaces to discolouring and yellowing
- Annual periods of use
- Switching frequency
- Accessibility and cleaning or maintenance intervals
- Use of more or less economical equipment, for example, electronic ballasts (EB)

The maintenance factor directly influences a system's energy efficiency. High-quality luminaires and illuminants assume a key function in that. In combination with luminous flux adjustment, the energy consumption can be influenced additionally. Since the power requirement is proportional to the illuminance, time-dependent control of the illuminance based on the time course of the maintenance factor can be used to optimise the power requirement and to reduce the energy consumption – as described in [21] (see Fig. 16/4).

The planner's tasks:

- Determination of the maintenance factor
- Identification of the influencing factors
- Definition of the maintenance plan

When planning with LED luminaires it has to be minded that the manufacturers' specifications are applicable to a limited extent only. The LED's performance is considerably influenced by the luminaire. The decline in luminous flux depends on the respective current load, the thermal management and the ambient temperature of the luminaire. The better the luminaire manufacturer's thermal management, the lower the decline in luminous flux of the luminaire over time in the respective surroundings.

*Example: LED luminaire, specification L70/B50 at 50,000 operating hours. After 50,000 h, the luminous flux of 50% of the modules (B50) will still be at least 70% (L70) of the initial luminous flux. The luminous flux and lifespan*

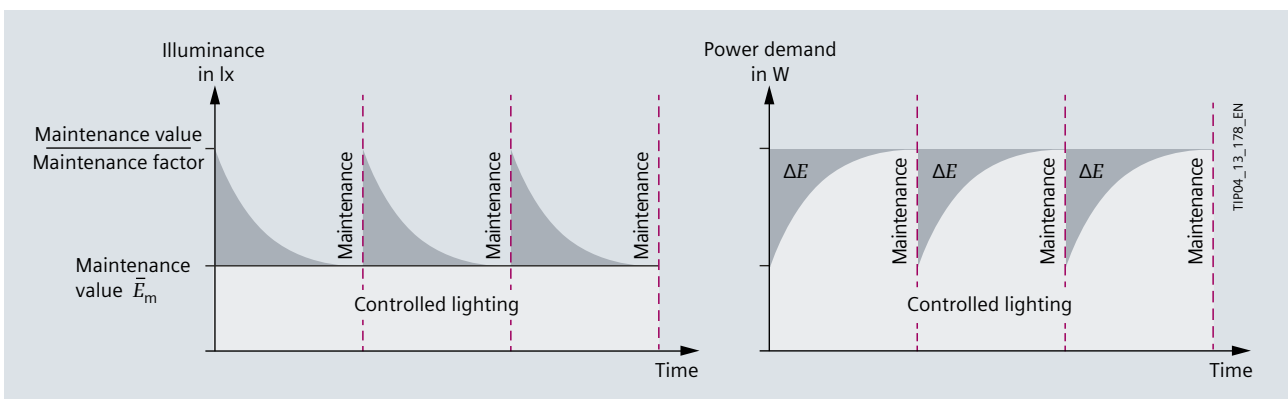

Fig. 16/4: Operation-dependence of illuminance, power demand and energy saving  $\Delta E$  (dark grey areas in the right-hand diagram) for controlled lighting with constant illuminance

behaviour of LED modules is described in the standard IEC/PAS 62717.

If the system will presumably be in operation for less than 50,000 h, a correspondingly lower luminous flux decline value has to be assessed! The luminaire manufacturers are obliged to publish information on their luminaires. For detailed explanations and planning notes, specifically for LED lighting, refer to the ZVEI Guide "Reliable Planning with LED Lighting" [22] and to LiTG publications.

### 16.3.2 Normative Specifications as to Energy Efficiency

The European Parliament and the Council of the European Union stated in Directive 2006/32/EC that 78% of the greenhouse gas emissions of the European Community are caused by human activities that are referable to the energy field. The directive's objective is to increase the efficiency of the final energy use cost-effectively in the member states.

EnEV 2009 [23] is the implementation of Directives 2002/91/EC and 2006/32/EC into a German regulation in accordance with the specifications of the European Union. In compliance with that, the energy consumption in non-residential buildings is to be determined for the installed lighting and stated in kWh per year and square meter of the net floor area. The target value is the annual primary energy consumption of a building per square meter of the net floor area.

With regard to the calculation of the energy demand of the lighting, EnEV 2009 refers to DIN V18599-4: 2007-02 and provides different methods for the planning of a lighting system taking into account a specific type of lighting and a use-specific maintenance value of the illuminance. As a requirement basis for non-residential buildings, EnEV 2009 states specific component and system designs of a reference building, among them also for the lighting:

- Glass roofs, lighting strips, light domes
- Windows, French doors, skylights
- Daylight supply in the case of sun and/or glare protection, shading
- Type of lighting, lighting control

In particular for lighting control, EnEV 2009 provides specifications for the different types of use of a building in accordance with DIN V18599-10:2007-02 (see Tab. 16/2).

EnEV 2009 has been revised to EnEV 2014 for two reasons:

1. Transposition of Directive 2012/27/EU with higher requirements into German law
2. Reference to the new pre-standard series DIN V18599. For the lighting, DIN V18599-4:2011-12 replaces DIN 18599-4:2007-02 to which EnEV 2009 refers.

Publication of EnEV 2014 was in May 2014.

This also results in a change to the current DIN V18599-4:2011-12 and for lighting control a daylight-dependent control is considered in the constant light control (Tab. 16/3).

For the planning of energy-efficient lighting in compliance with EnEV, DIN V18599-4 is applied. In that, the different utilisation zones of the building, the specific electrical efficiency of artificial light, the consideration of the daylight utilisation and the influence of presence detection systems are determined.

It has to be noted that EN 15193 is a European standard serving a similar purpose as DIN V18599-4. The "exhaustive" energy demand calculation method presented in EN 15193 complies with DIN V18599-4 (EN 15193 is currently being revised due to the revision of Directive 2010/31/EU on the building efficiency). In the national annex NA of EN 15193 for Germany, it is stated that the installed illuminance in accordance with DIN V18599-4 has to be determined with one of the following alternatives:

- Tabular method
- Efficiency factor method
- Detailed specialist planning

Software-based tools considering all installations are provided for the calculation. The electrical and lighting planning engineer can use, for example, the lighting calculation programs DIALux or RELUX to calculate the reference value to be observed for the energy demand. The lighting calculation programs are able to calculate the value for the net energy demand of the lighting by applying the formulas described in DIN V18599-4.

More information about DIALux and RELUX can be obtained on the Internet at: [osram.com/osram\\_com/tools-and-services/tools/dialux-and-relux/index.jsp](http://osram.com/osram_com/tools-and-services/tools/dialux-and-relux/index.jsp)



Lighting control		for types of use in accordance with DIN V18599-10:2007-02
Presence control	effected by presence detector	Meeting, conference, seminar, kitchen (preparation, storage), lavatories and sanitary facilities in non-residential buildings, other common rooms, ancillary areas (without common rooms), circulation areas, server room, data centre, gym (without grandstand)
	effected manually	otherwise
Daylight-dependent control	effected manually	all
Constant light control	available	Meeting, conference, seminar, kitchen (preparation, storage), lavatories and sanitary facilities in non-residential buildings, other common rooms, ancillary areas (without common rooms), circulation areas, server room, data centre, gym (without grandstand)
	not available	otherwise

Tab. 16/2: Lighting control in accordance with EnEV 2009

[back to page 308](#)

Lighting control		for types of use in accordance with DIN V18599-10:2011-12
Presence control	effected by presence detector	Cellular office and group office, meeting, conference, seminar, class room (school), group room (kindergarten), lecture hall, auditorium, hotel room, kitchen (preparation, storage), lavatories and sanitary facilities in non-residential buildings, other common rooms, circulation areas, server room, data centre, sports hall / gym (without grandstand), car parks (office or private use), laboratory, examination and treatment rooms, doctor's surgeries and therapeutic surgeries
	effected manually	otherwise
Constant light control / daylight-dependent control	Constant light control effected in accordance with DIN V18599-4:2011-12 Section 5.4.6	Counter area, lecture hall, auditorium, wards, kitchens in non-residential buildings, commercial and industrial halls, library – open access section, car parks (public use), fitness room, examination and treatment rooms, special nursing areas, corridors of the general nursing area, doctor's surgeries and therapeutic surgeries
	Daylight-dependent control in combination with constant light control is effected in accordance with DIN V18599-4:2011-12 Section 5.5.4	Cellular office, group office (two to six workplaces), open-plan office (from seven workplaces on), conference room, meeting room, seminar, class room (school), group room (kindergarten), cafeteria, library – reading room, sports hall / gym (without grandstand), laboratory
	effected manually	otherwise

Tab. 16/3: Lighting control in accordance with EnEV 2014

[back to page 308](#)

### 16.3.3 Design Guidelines for the Biological Effect of Lighting

For a long time, the biological effect of light on the human being had been regarded as a mainly medical topic. This changed when another photoreceptor was discovered in the human eye (in 2001). Light is perceived with light-sensitive sensory cells and passed on to the body in biological signals. For example, the production of melatonin is regulated, a hormone that controls the body's circadian rhythm and is sensitive to blue light.

Light influences physiological and psychological states such as moods, emotions and also attention. Thus, lighting can have a controlling impact on people's health and well-being. Intelligent lighting planning is not just restrained to the technical aspects of lighting, but also considers the

biological factors connected with the "human photo-receiver" – thus, not only the visual factors, but also the non-visual factors (Fig. 16/5). That is, for artificial light, energy in different spectral ranges is used, which are not required for the actual visual process. Therefore, it may happen that the biological effect of light theoretically opposes an efficient energy use, but in a holistic view, it is reasonable also in an efficient energy use approach.

DIN SPEC 67600 is not a standard in the conventional sense of lighting planning, but a recommendation to consider for the planning the biological effect of light on the human eye and body. Some notes in DIN SPEC 67600 are important:

- Preference of daylight in the planning; artificial light should be a supplement and only a substitute where daylight is not sufficiently available

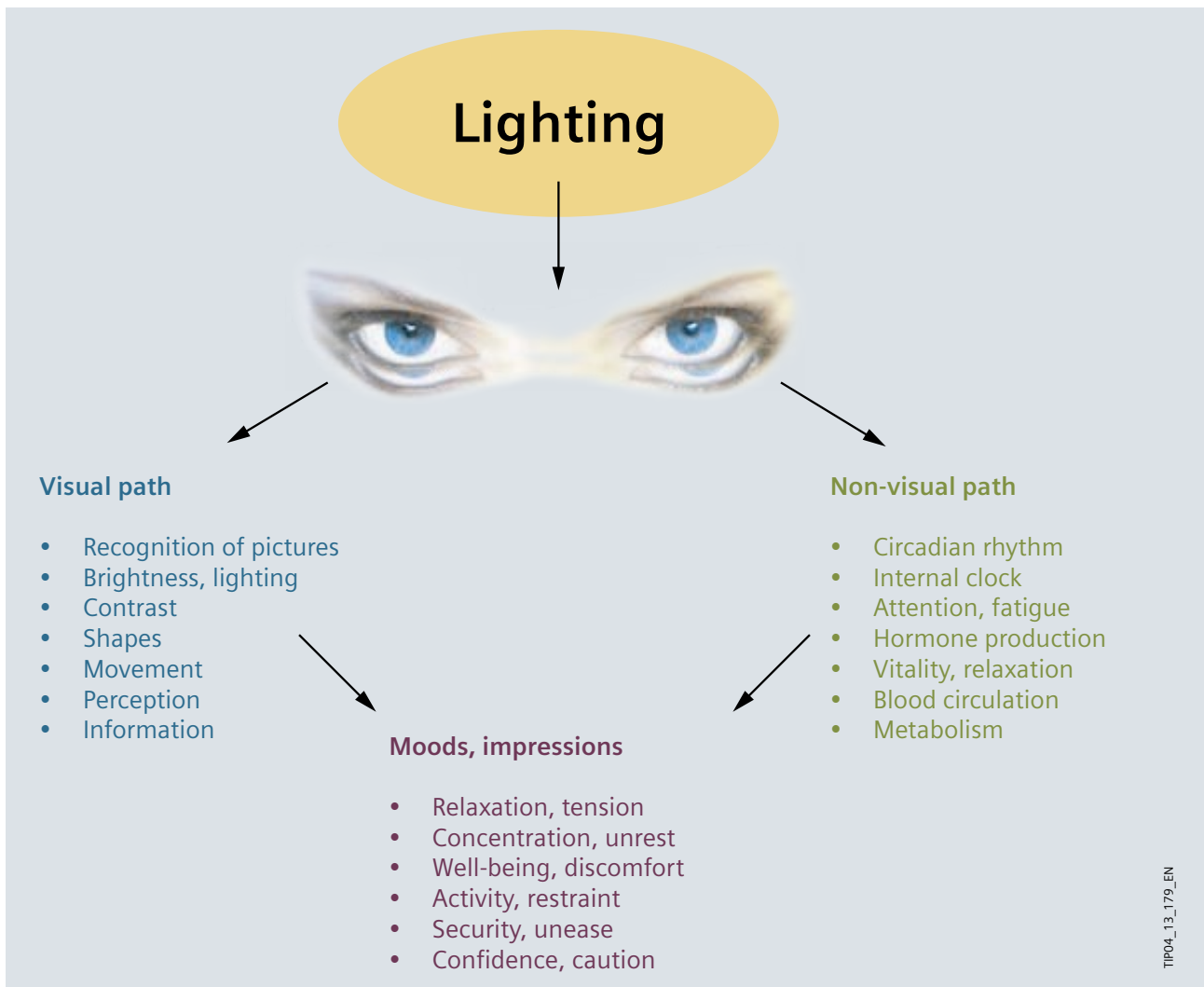

Fig. 16/5: Effects of light

TIP04\_13\_179\_EN

- Visual requirements on the lighting planning are described in EN12464-1 and for workplaces in ASR A3.4 (binding for Germany)
- Integrated planning taking into account the biological effect of light is structured according to the HOAI phases (German Fees Ordinance for Architects and Engineers): requirements planning – basic evaluation – preliminary planning etc.

As criteria for biologically effective lighting, DIN SPEC 67600 explicitly describes the following aspects:

- Spectral composition of the light:  
The natural circadian rhythm of the human body (chronobiological effect of the so-called “internal clock”) is determined by the increased red component at sunrise or sunset on the one hand, and the lower illuminance before and after sunrise on the other hand (despite the increased blue component in the light spectrum). This colour effect in connection with the illuminance can also be used for artificial light. To be considered for that is that reflections and transmissions as well as the spectral properties of materials may have considerable influence on the light. For example, wooden elements and floors or walls in earthy browns can reduce the blue component in the light. The correlation between colour temperature and biological effect is shown schematically in DIN SPEC 67600 (Fig. 16/6)
- Illuminance:  
As reference value for a biological effect, DIN SPEC 67600 specifies 250 lx for the vertical illuminance at a correlated colour temperature of 8.000 K at the viewer’s eye. For illuminated surfaces, the reflectance coefficients of the surfaces play an important part, and the upper limit

values of the reflectance coefficients specified in EN 12464-1 should be reached

- Geometrical arrangement of the light:  
Beyond the requirements of EN 12464-1, the following has to be observed with regard to the geometrical arrangement for biologically effective lighting:
  - Area and solid angles (for example, small light sources do not contribute to the biological effect, bright areas are to be aimed at)
  - Light direction (for example, the wide-area lighting of bright areas should be visible in the upper part of the visual field)
- Light dynamics:  
The adaptation of the light to the time of day and time of year or even to the weather plays an important part. The circadian rhythm can be stabilised with biologically effective light, for example, when the melatonin production is reduced before falling asleep. When the daylight has only low illuminance, it may be desirable to supplement it with biologically effective artificial light. Since the human biological system responds relatively slowly, the duration of the light exposure is an important factor for the biological effect, resulting in a restriction to rooms with longer dwell times
- Energy efficiency of biologically effective lighting:  
Wide-area light from the top makes for a more distinct biological effect, as the receptor cells in the eye’s retina are reached better and more uniformly. However, this usually requires more power installed to achieve the desired illuminance in the case of spatial distribution of the light. According to experience values – as noted in DIN SPEC 67600 – the installed power increases by factor 3. However, in a conversion to biologically effective lighting, an efficient new system with modern luminaires and lighting systems can at the same time make for a relative decrease of the energy consumption (see section 16.5.2 and section 16.5.3). Due to the modernisation and use of lighting management systems, the increase of energy consumption in a conversion to biologically effective lighting is limited to about 25% (in accordance with DIN SPEC 67600)

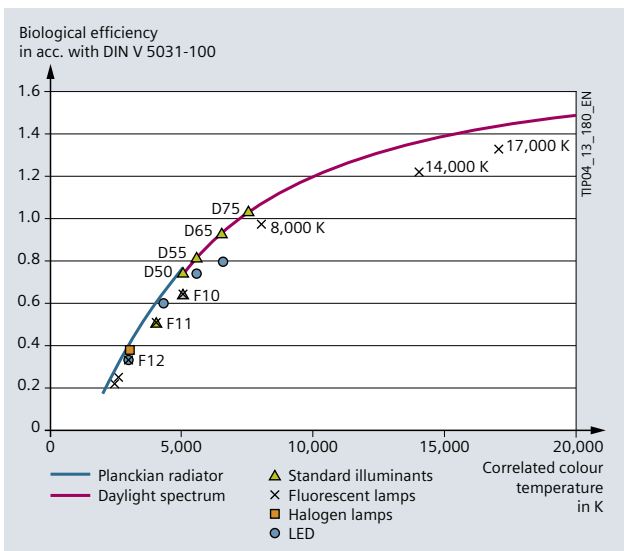

Fig. 16/6: Biological efficiency factors as a function of the correlated colour temperature in accordance with DIN SPEC 67600

## 16.4 Lighting Scheme

For a lighting scheme, the requirements described in EN 12464-1 have to be implemented project-specifically. For that, the rooms are divided into the visual task area(s), the respective immediate surroundings and the background (Fig. 16/7).

Room structuring serves for the planning of a balanced luminance distribution and thus for an adaptation to different illuminance levels in the room that is favourable for the human eye. The requested uniformity  $U_0$  is specified in EN 12464-1 for the different rooms. For the immediate surroundings,  $U_0 = 0.4$  is assessed, and for the background  $U_0 = 0.1$ .

The spatial recognisability of faces, bodies or objects in the room is basically characterised by the mean cylindrical illuminance. Directional light can highlight visual details. In buildings and in areas for which good visual communication is important, in particular in offices, meeting rooms and class rooms, the mean cylindrical illuminance should not be less than 150 lx.

Glare may considerably impair the sight. It diminishes the visual performance (disability glare) and visual comfort (discomfort glare). A differentiation is to be made between direct glare and indirect glare. Direct glare comes from luminaires or other areas with excessive luminance, for example, the incidence of light through windows. Glare by reflection acts indirectly, caused by reflections on shining surfaces.

### 16.4.1 Design Principles

In addition to the general or basic lighting, it is reasonable to use lighting for visual focussing or emphasising. In that, architecture, design elements in the room, forms, materials or surface properties are immersed in light. This can also be used to draw the viewer's attention to something or to foreground the light itself as an object of viewing (catchword: light sculpture). The following questions are to be asked in particular:

- Where do I want to achieve the effect? Where is the light focus to be created?  
Light direction (top, bottom, lateral, vertical, horizontal etc.) and light distribution (punctiform, wide-area, accentuated etc.)

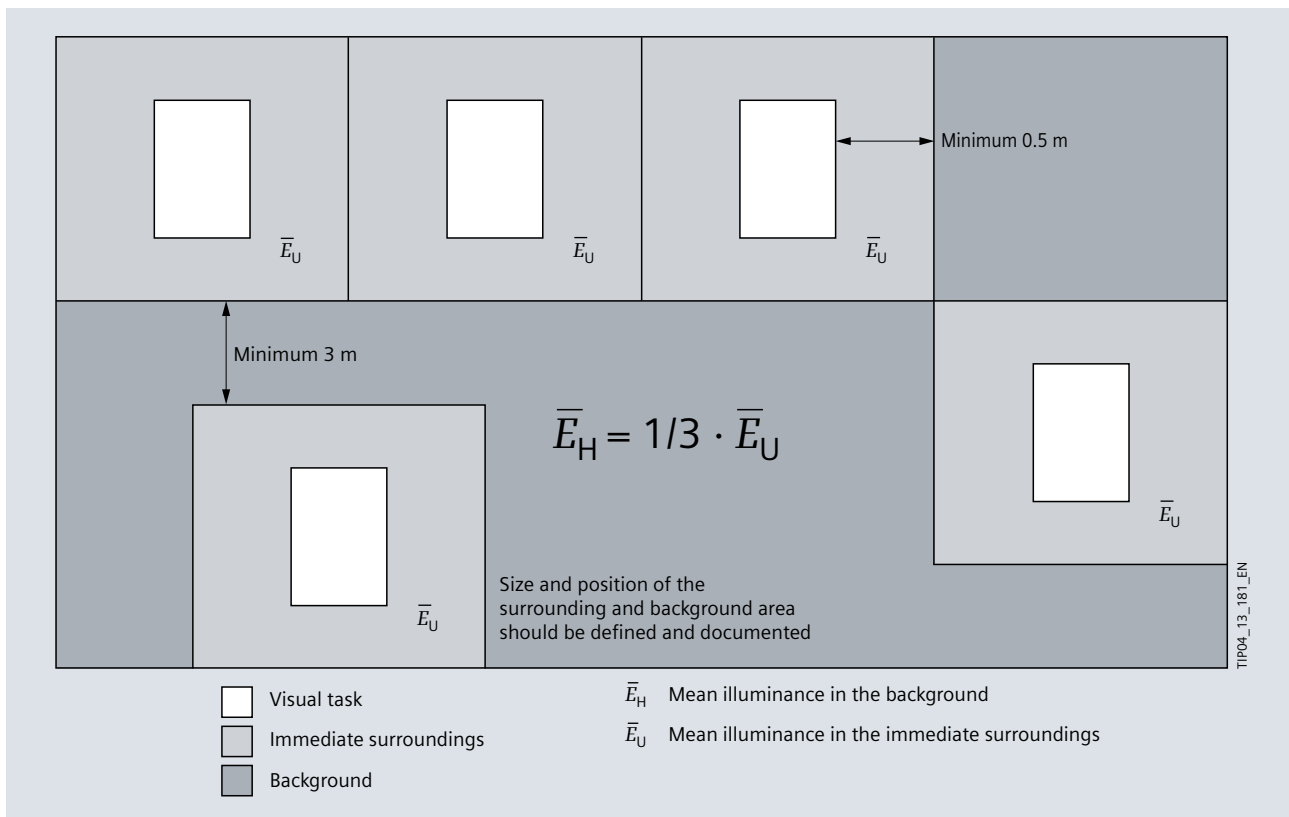

Fig. 16/7: Room structuring for the lighting concept

- How do I want to achieve the effect?  
For example, through colour contrasts, different illuminances, colour temperatures, light density beam focusing or scattering and adjustable light effects (time-, environment-, event-dependent)
- Which design functions are to be assumed by lamps and luminaires?  
Architectural integration through form language, arrangement, number, grid, bundling etc.

Possible mounting positions for the lighting systems are defined on the basis of the structural conditions. This conception results in the required light distribution curve (LDC), which is characterized by the spatial distribution (for example, a symmetric, asymmetric, wide-angle, or narrow beam LDC).

The selection of the required LDC and illuminants leads to the selection of the corresponding luminaires, taking into account the lighting task, design intention and mounting options. Finally, the mounting positions are checked and tailored to the space requirements of the lighting system. Also to be considered is any additional equipment and cooling elements for the luminaire or stipulated clearances.

### 16.4.2 Illuminants

The light quality is primarily determined by the selection of the illuminants. Specific properties such as light colour, colour rendering, efficiency, dimming behaviour, and dimensions should be considered for the selection and combination of illuminants.

The selection of the light colour is a matter of taste, design and application. The light colours influence the room atmosphere: warm white light is mainly perceived as cosy and comfortable, neutral white light rather as unemotional. The light of lamps with the same light colour may have different colour rendering properties. The minimum values for the colour rendering property (colour rendering indexes  $R_a$ ) are stated in the tables of DIN EN 12464-1 dependent on the areas of activity. For a comprehensive overview of the illuminants, refer to the Appendix.

### 16.4.3 Lighting Tools

The objective of good lighting planning is to design a visual environment and its usage with the help of light. In that, light serves as a tool, motivation aid, inspiration, attraction, for presentation, marketing etc. To this end, the designer has to use suitable lighting tools, which goes far beyond the arrangement of illuminants in the room. The designer's professional and creative handling of lighting tools ensures an optimal lighting system. For this purpose, designers draw

on luminaires that work efficiently and sustainably, optimally comply with normative, qualitative and design requirements, have long maintenance intervals and are easy to assemble.

The term "luminaire" describes the entire lighting appliance including all components required for fixing, operation and protection of the illuminants – in colloquial speech often referred to as "lamp". Luminaires are differentiated by:

- the type of illuminant used (for energy saving lamps, for fluorescent lamps, for discharge lamps)
- the number of illuminants (single-, two-lamp etc.)
- the field of application (interior lamps, exterior lamps)
- the place of installation (desk luminaires etc.)
- the degree of protection (luminaires specifically for dry, humid and dusty rooms)
- the design (open, closed, reflector, mirror, louvre, diffuser luminaires, spotlights)
- the mounting type (wall, ceiling, pendant or portable luminaires)
- the intended purpose or lighting task (technical luminaires, housing luminaires, decorative or effect luminaires, workplace luminaires etc.)

### Lighting engineering properties

The selection of suitable luminaires is determined by:

- the distribution of the luminous flux and luminous intensity (light distribution curve – LDC)
- the light output ratio
- the glare limitation
- the photobiological safety

Luminaires distribute, deflect and transform the light emitted by the illuminant. Every illuminant type has a specific light output. This is referred to as luminous flux, stated in lumen (lm). The LDC is the basis for lighting planning in indoor and outdoor areas. It determines the local illuminance distribution and is used as a reference for glare assessment.



The luminaire's light output ratio describes, how effectively a luminaire distributes the light of an illuminant. The higher it is, the less energy has to be spent to achieve the desired illuminance.

The luminaire's glare limitation mainly serves for improvement of the lighting quality, for example, through light deflexion as in SITECO ELDACON luminaires ([osram.com/osram\\_com/news-and-knowledge/the-biological-effects-of-light---light-means-quality-of-life/index.jsp](https://osram.com/osram_com/news-and-knowledge/the-biological-effects-of-light---light-means-quality-of-life/index.jsp)). Glare may arise as direct glare or glare by reflection. The cause of direct glare is excessive luminance, for example, due to unsuitable or incorrectly installed luminaires, unshielded lamps, or even through windows. Glare by reflection is

caused by reflections on shining surfaces, for example, on screens, glossy paper or even on wet streets.

Direct glare can be prevented by sufficiently screened luminaires and tinted windows. Protection against glare by reflection is provided by a correct arrangement of the luminaires in the room, a luminance limitation and the use of matt surfaces.

The requirements of IEC 62471 (VDE 0837-471) for photobiological safety regulate the protection of skin and eye against optical radiation [25]. This standard must also be observed for CE marking. Depending on the degree of danger, lamps are classified into four different groups. Risk group 3 is not allowed for general lighting and risk group 2 must be marked as described in the standard. Risk groups 0 and 1 need no marking. The standard IEC 60598-1 (VDE 0711-1) points out that luminaires require the application of IEC 62471 (VDE 0837-471).

	Safety class I	Luminaires for connection to the line-side protection conductor. The symbol is applied at the connecting point.
	Safety class II	Luminaires with additional or reinforced insulation. They do not provide a protection conductor connection.
	Safety class III	Luminaires for operation with safety extra-low voltage.

Tab. 16/4: Symbols for safety classes in accordance with IEC 61140 (VDE 0140-1)

### Electrical properties

The electrical properties of the luminaire are decisive for safe and fault-free operation. The case of application plays an important part for luminaire selection.

These electrical properties are generally regarded as important:

- Protection against excessively high touch voltage with safety classes in accordance with IEC 61140 (VDE 0140-1, see Tab. 16/4)
- Protection against the ingress of foreign bodies and moisture with the degrees of protection in accordance with IEC 60529 (VDI 0470-1, see Tab. 16/5)
- Electromagnetic compatibility (EMC in accordance with EN 55015/VDE 0875-15-1, IEC 61000-3-2/VDE 0838-2 and IEC 61000-3-3/VDE 0838-3)
- Immunity to interference in accordance with IEC 61547 (VDE 0875-15-2)
- Exposition of persons to electromagnetic fields (IEC 62493/VDE 0848-493)
- Fire protection
- Protection against flying balls: In gymnasiums, balls hitting luminaires at full tilt must not damage these so severely that parts of it fall down (VDE 0710-13)

To meet the safety requirements on lighting, the luminaires must comply with the standard series IEC 60598 (VDE 0711). As a prerequisite for that, also the associated electrical components must comply with the relevant safety regulations (for example, the standard series IEC 61347/VDE 0712 for equipment). Moreover, also the so-called performance requirements for the equipment's principle of operation should be considered and observed. To indicate conformity with the standards, the luminaires should carry the ENEC approval mark.

First code figure		Second code figure	
0	Not protected	0	Not protected
1	Protected against solid objects with 50 mm in diameter and more	1	Drip-proof against vertical drops
2	Protected against solid objects with 12.5 mm in diameter and more	2	Drip-proof when tilted at angles of up to 15°
3	Protected against solid objects with 2.5 mm in diameter and more	3	Rain/spray-proof
4	Protected against solid objects with 1.0 mm in diameter and more	4	Splash-proof
5	Dust-accumulation protected	5	Jet-proof
6	Dust-penetration protected	6	Strong jet-proof
		7	Watertight
		8	Pressure watertight

Tab. 16/5: Degrees of protection in accordance with IEC 60529 (VDE 0470-1)

To ensure standard-compliant performance also for the luminaires, in particular LED luminaires, the standards IEC/PAS 62722-1 and 62722-2-1 were published (here, PAS stands for “publicly available specification”). These standards are currently being prepared as drafts for European standards (EN 62722-1 and EN 62722-2-1). The requirements are already met in the development of LED luminaires, which is of great importance for the planning of lighting systems [22].

### Degrees of protection

The degree of protection of a luminaire indicates whether it is suitable for the desired lighting application and can be operated safely. The luminaires must be constructed such that no foreign bodies or moisture can ingress. The degree of protection is indicated on the luminaire; the IP code is applied for marking. The first code figure after the abbreviation “IP” (international protection) describes the protection against the ingress of foreign bodies, the second code figure the protection against the ingress of water (see Tab. 16/5).

### Constructional properties

The building’s ceiling construction influences the selection of luminaires. The luminaire design is differentiated into free-standing luminaires, surface-mounted luminaires, recessed luminaires or pendant luminaires. The mounting and maintenance options are an additional criterion for the luminaire construction. The luminaire design (housing form, surface structure and colouring) has a significant influence on the appearance of interiors and becomes more and more important in the subjective decision in favour of or against a luminaire. Objective distinguishing features are reliability, economic efficiency and stability of value.

- **Free-standing luminaires** such as Futurel® 5MS or Futurel® LED are lighting systems that are individually dimmable and locally adjustable.



- **Pendant luminaires** such as ARKTIKA-P LED are suspended from the ceiling on steel wires or threaded rods. They are thus also design elements and optionally available with direct/indirect light distribution.



1

- **Surface-mounted luminaires** such as Quadrature®2 are mounted visibly on the ceiling. They are thus part of the room impression and a means of architectural designing.



2

3

4

5

6

7

- **Recessed ceiling luminaires** such as Mira®LED are suitable for mounting in cavities or ceiling voids. Most of the luminaire is put into the ceiling out of sight. The luminaire face is often flush with the ceiling.



8

9

10

11

12

13

14

15

16

17

- **Downlights** are special, normally round ceiling luminaires fitted with reflectors and other optical elements (such as Lunis® 2), which can also be swivel-mounted. They are available as recessed downlights for recessed mounting in ceilings and as surface downlights for surface mounting on ceilings.



- **Strip lighting systems** are aligned and through-wired luminaires for surface or recessed mounting (such as Modario®), which can be equipped with different covers (reflector, louvre, microprismatic cover). They are also available with high IP protection for areas with increased dust density, for example in workshops. Strip lighting systems are suspended and are optionally available with an indirect lighting component to lighten the ceiling. Strip lighting systems can be used flexibly, as luminaires and spotlights can be applied at any position on the bar via adapters.





- **Moisture-proof luminaires** comply at least with degree of protection IP X4 (such as Monsun®). They are primarily used in industry and trade as well as in garages and cellar rooms. A positive side effect of the higher degree of protection is often a lower sensitivity to dirt and associated with that an extension of the maintenance intervals.



the single facets, the so-called light point resolution arises. Glare is minimised by that. At the same time, the many facets provide for very uniform lighting. Due to the lamp's low mounting position, maintenance is also facilitated. Under normal conditions, the mirror remains maintenance-free.



- **High-bay/mirror hall luminaires** (such as NJ600) are primarily useful for high halls. The luminaires have a rotation-symmetric and narrow-angle intensity distribution.



- **Floodlights and projectors** are designed for lamps with high power ratings (in watt). Lamps with lower power ratings are used in spotlights or mini floodlights. In outdoor lighting, floodlights lend themselves to applications such as the illumination of buildings. Indoors, their principal application is theatrical stage lighting and stadiums (such as FL Midi S).



- **Mirror reflector systems** (such as Mirrortec®) can be used for uniform and directed wide-area lighting. Light is directed from a very tightly bundled lamp to a multi-facet mirror and there reflected either symmetrically or asymmetrically, depending on the properties of these mirror facets. The application-specific selection of the lamp and mirror and the distance between these two allows for special lighting comfort. Compared to conventional luminaires, the light source is fractionalised into single points of light with low intensity via the multi-facets system. Depending on the viewer's position and size of

For more information, see [siteco.com/en/uk\\_en/products/indoor-luminaires-catalogue.html](http://siteco.com/en/uk_en/products/indoor-luminaires-catalogue.html)

## 16.5 Lighting Calculation

In the next step of professional lighting planning, the lighting concept is reviewed on the basis of the specifications for the simplified efficiency factor method as described in the standard DIN V18599-4. The electrical efficiency referred to a floor area can be determined for a calculation area with the following formula:

$$p_j = \frac{k_A \cdot \bar{E}_m}{MF \cdot \eta_S \cdot \eta_{LB} \cdot \eta_R}$$

Where

- $p_j$  Electrical efficiency referred to the floor area considered
- $k_A$  Reduction factor, considering the boundaries of the visual task
- $\bar{E}_m$  Maintenance value of illuminance in accordance with DIN V 18599-10
- $\eta_S$  System light output of illuminant plus equipment
- $\eta_{LB}$  Light output ratio of the luminaire applied
- $\eta_R$  Room efficiency factor
- $MF$  Maintenance factor

This formula is an adaptation of the equation presented by the Deutsche Lichttechnische Gesellschaft e. V. (LiTG – German Light Engineering Society) for a simple estimation of the required number of luminaires or lamps referred to the desired illuminance [26]:

$$n \cdot z = \frac{E_n \cdot A}{\Phi \cdot \eta_B \cdot \eta_R \cdot MF}$$

Where

- $n$  Number of luminaires
- $z$  Number of lamps per luminaire
- $E_n$  Rated illuminance
- $A$  Floor area of the room
- $\Phi$  Luminous flux of lamp
- $\eta_B$  Total luminous efficacy
- $\eta_R$  Room efficiency factor
- $MF$  Maintenance factor

For this equation, the following correlations apply with regard to the luminous fluxes:

$$\eta_B \cdot \eta_R = \frac{\Phi_N}{\Phi_{tot}}$$

$$\Phi_N = \frac{E_n \cdot A}{MF}$$

$$\Phi_{tot} = n \cdot z \cdot \Phi$$

Where

- $\Phi_N$  Usable luminous flux
- $\Phi_{tot}$  Total luminous flux of lamps

The room efficiency factor  $\eta_R$  is dependent on the luminous flux distribution of the luminaire, the room geometry and the reflection conditions in the room. The relevant data are stated in the LiTG publication no. 3.5 [27].

To simplify distinctions, DIN V18599-4 introduces three types of lighting: "direct", "direct/indirect", and "indirect", and specifies corresponding room efficiency factors dependent on the room index  $k$  in a table. The room index  $k$  is calculated as follows:

$$k = \frac{a \cdot b}{h_N \cdot (a + b)}$$

Where

- $a$  Room depth
- $b$  Room width
- $h_N$  For "direct" or mainly "direct" lighting: difference in height between luminaire plane and working plane  
For "indirect" or mainly "indirect" lighting: difference in height between ceiling and working plane

The table values for the room efficiency factor can be interpolated. For simplification, Fig. 16/8 shows three interpolated curves for the correlation between room index and room efficiency factor.

### 16.5.1 Lighting Calculation Programs

Special software programs assist in the calculation of a lighting system. With the efficiency factor method, the number of luminaires required for a given illuminance can be determined. The illuminances at relevant points in the room are calculated by the computer. The lighting engineering result is output in various display forms (mean value, iso-illuminance curves, value tables, diagrams). Moreover, a clear picture of the lighting system is conveyed (Fig. 16/9).

The lighting simulation has proven to be a helpful method to visualise and review the lighting. Compliance with the applicable national or international guidelines is proven. For professional lighting simulations, the user applies specialised software such as DIALux or RELUX.

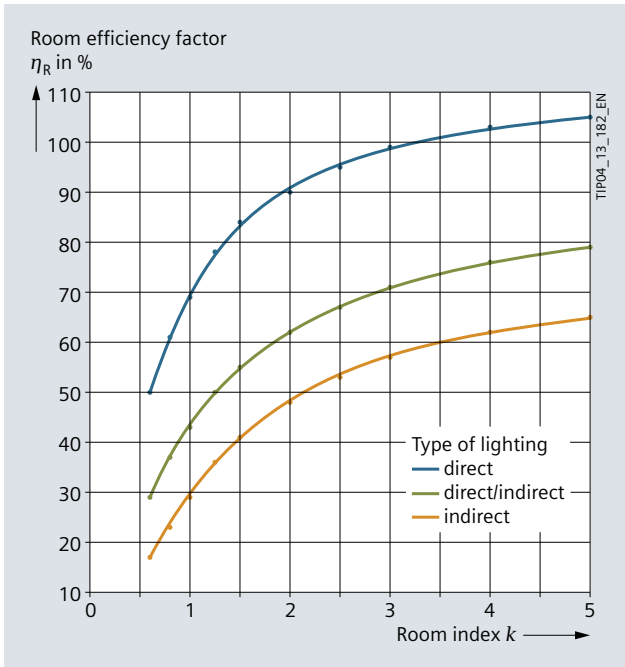

Fig. 16/8: Room efficiency factor  $\eta_R$  as a function of the room index  $k$  [back to page 318](#)

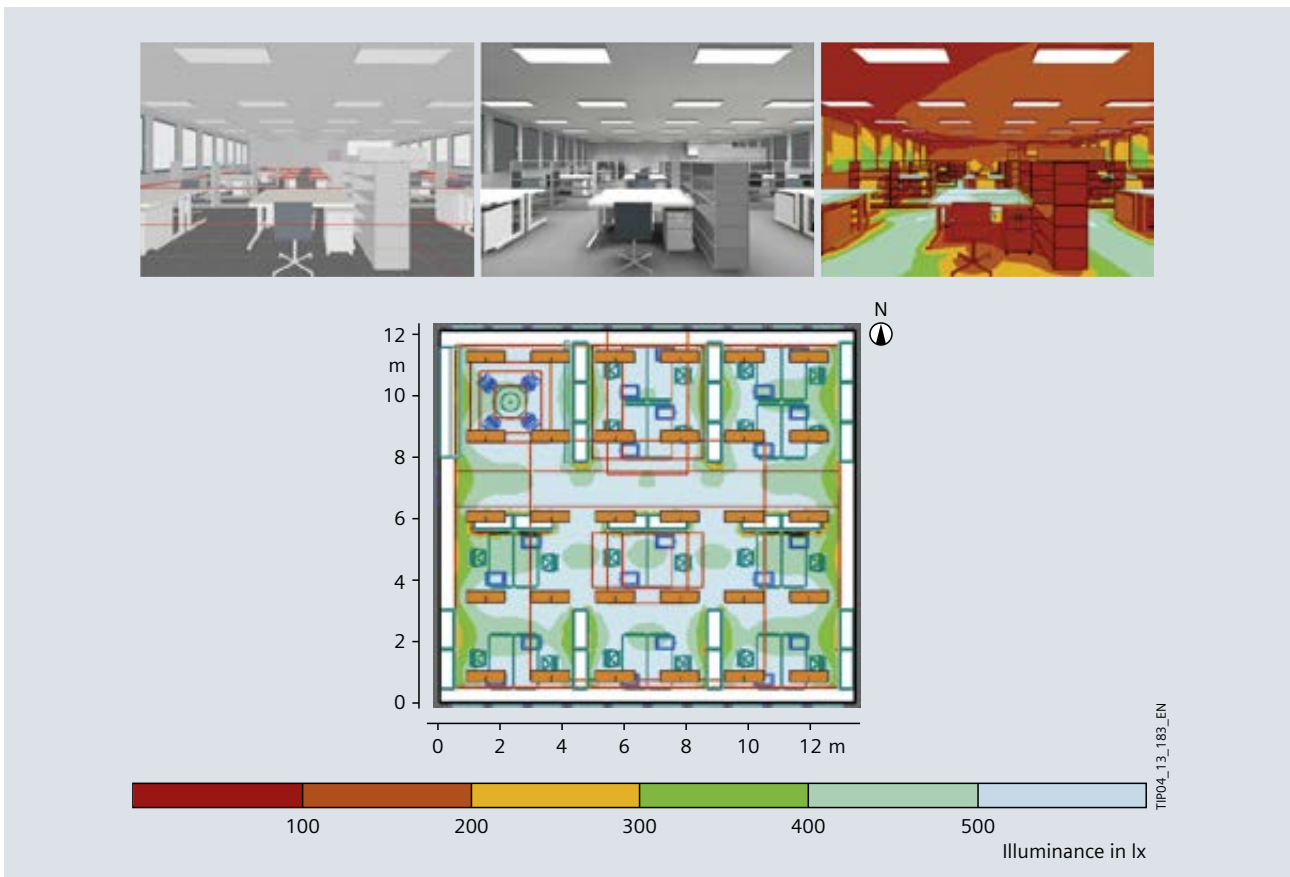

Fig. 16/9: Example of a calculated spatial distribution of the illuminances in an office

Additional planning support by manufacturer-based online tools:

- **Sample systems:** The sample systems from SiTECO and OSRAM are sample calculations of lighting systems with various luminaires of the respective application. The calculations comply with the normative specifications. The sample systems can be downloaded as RELUX file and PDF, edited and saved. Numerous applications are available under the headings industry, office, shop, street & urban, and sports at [siteco.com/en/planning-guide/sample-projects.html](http://siteco.com/en/planning-guide/sample-projects.html)
- **SiTECO Lighting Tool:** The tool facilitates the transfer of product-specific data to the lighting planning programs RELUX and DIALux, as the product selection of luminaires is possible with just a few clicks. The product ranges indoor and outdoor are available. For download, go to: [siteco.com/en/planning-guidelighting-calculation.html](http://siteco.com/en/planning-guidelighting-calculation.html)

## 16.5.2 Lighting Management Systems

Lighting management systems (LMS) autonomously recognise and control different light levels. However, the user can also determine the desired light level himself any time, for example, the lighting to dim the incident daylight. LMS thus allow for need-based lighting control. Through intelligent and need-based lighting control, the requirements of comfort and energy saving intermesh seamlessly.

Apart from well-being and function, the priority of lighting management is also to consider energy efficiency as a constant of the lighting solution. Depending on the task, a differentiation is made for interior rooms between luminaire, room, and building solutions:

- **Luminaire solutions:**  
Time-dependent, daylight- and presence-dependent luminaire control, for example, a free-standing luminaire with an integrated brightness and presence sensor to switch off the luminaire automatically with a time delay as soon as there is nobody in the room any more
- **Room and building solutions:**  
Luminaire groups are set to different switching and dimming states, which can be called via the LMS as defined light scenes

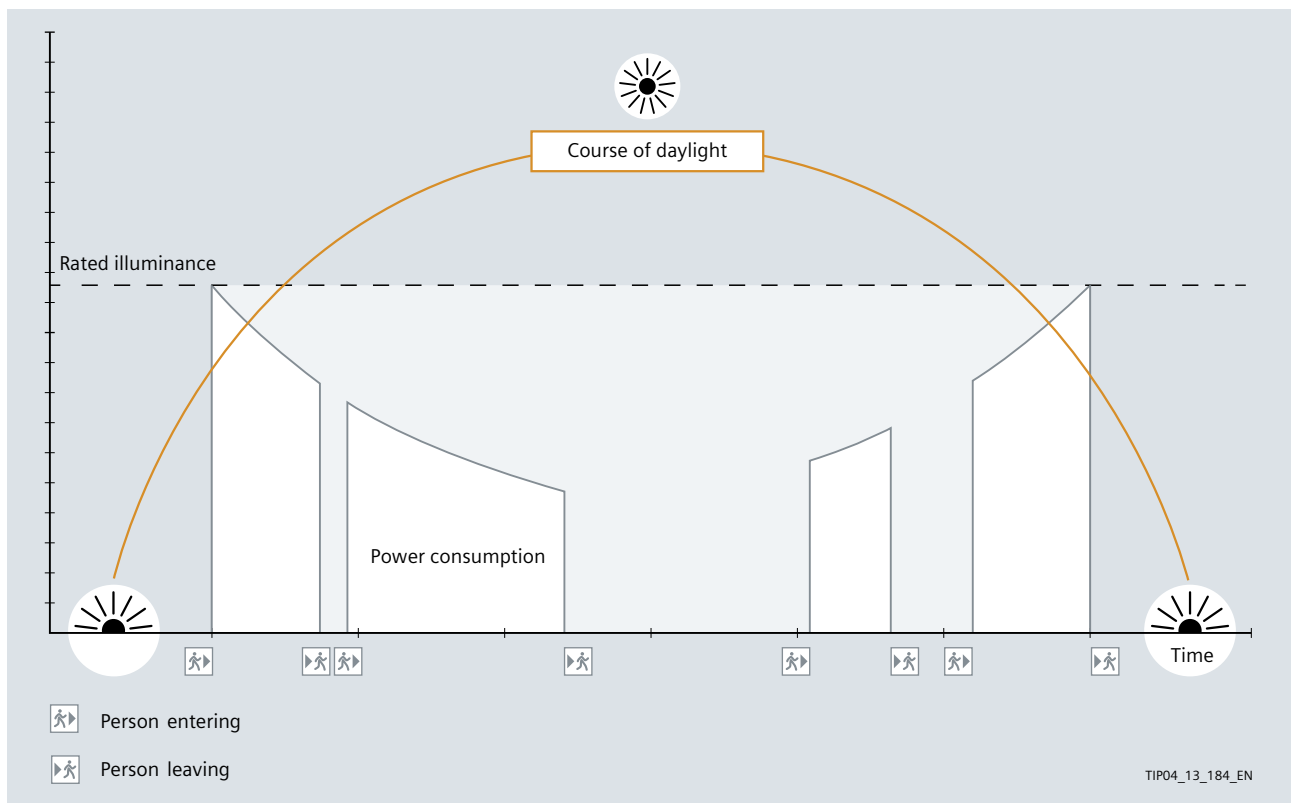

Fig. 16/10: Daylight- and presence-dependent lighting requirements for an assembly facility

[back to page 321](#)

By using a LMS for offices and industrial buildings, considerable energy savings can be achieved if a daylight- and presence-dependent lighting control complements the available daylight (Fig. 16/10). Light sensors detect the existing light level and automatically control the additional light input. The user can manually control the desired illuminance any time. If a motion/presence sensor is used in addition, the lighting only switches on automatically if people are in or enter the room. This again increases the savings potential considerably.

As an additional application, LMS allow for dynamic colour solutions which are easy to integrate and operate. Luminous intensity and colour for effect light can then be selected dynamically or at the push of a button. Application examples for so-called ambience lighting are: shops, showrooms and points of sale (PoS), fitness and wellness areas, restaurants, bars, hotel lobbies, conference rooms, schools, universities, further education institutions, façade illumination. For so-called scene-based lighting, moods can be enhanced or a biological effect can be caused, for example, activation through a high blue component in the light spectrum with high illuminance.

Typically, one of the following interfaces is used for LMS control:

- Dimming EB with 1...10 V interface:  
In this standard solution, ballasts and control unit are connected via a poled 2-core control line. The control current intensity determines the dimming position of the connected EB
- DALI for general lighting:  
Lighting control, sensors, operating units, electronic control gear and lamps communicate via the professional interface standard DALI (digital addressable lighting interface) and respond optimally to each other. DALI is a manufacturer-independent interface standard for dimmable electronic ballasts and provides high functionality as well as easy handling. Via a 2-core control line, a maximum of 64 DALI control gears can be flexibly controlled either individually or together and in up to 16 groups. Switching and dimming of the lighting is effected via the control line. A relay is not required. Important information such as the lamp status is saved in the control gear and forwarded to the control unit as information. Advantages as opposed to the 1...10 V interface (see Fig. 16/11):
  - The selection of the mains phase is independent of the control line
  - The DALI control line is protected against reverse polarity; a special bus cable is not required
  - One control line is sufficient for a maximum of 64 EB in up to 16 groups

- Switching of the luminaires can be effected through the control line
- A relay is not required
- The inrush currents are very low
- Feedbacks like “Lamp status” and “EB status” are possible
- Synchronous scene transitions, all relevant light values are saved in the EB
- Group allocation can be changed without rewiring

- DMX for effect lighting:  
DMX stands for “digital multiplex” and is another digital communication protocol for lighting control. DMX allows for the simultaneous control of up to 512 light channels. The data rate is rapid 250 kB/s. Especially lighting scenarios in which a large number of RGB light points and numerous dynamic, quick colour changes are required can thus be illuminated excellently. Dimmable control gear with DALI interfaces are able to implement DMX dimming commands exactly and in real-time
- EnOcean – wireless in buildings:  
EnOcean is a battery-free radio technology. The sensors get their energy from the proximity – tiny changes in movement, pressure, light, temperature, or vibration are sufficient to transfer radio signals. The maximum reach of the signals is 30 m inside buildings and 300 m in the free field. EnOcean transmits the signals on the licence-free 868 MHz frequency band. Clients benefit from EnOcean radio products in terms of planning flexibility and low installation costs. There is no wiring expense. This is a significant advantage not only in the planning phase but also in the later usage of the rooms. Adaptation of the wireless components to the room usage is straightforward. EnOcean light and presence sensors or wall push-buttons can be relocated without disturbing operational workflows and without causing any dirt or noise
- 3DIM and Powerline for outdoor lighting:  
3DIM can be used to implement three different control and dimming functions in one electronic ballast. Tab. 16/6 shows a simple comparison of the different scope of functions

In DALI mode, bidirectional communication takes place between the EB and LMS, as described above. StepDIM is used if a special control line (switched phase) is available in addition to the power supply line. In contrast, AstroDIM gets by without any control line, as a dimming profile can be preset in the 3DIM module.

With the Powerline technology, existing power supply systems can be utilised to create a network for the data transfer, without the need for an additional data cable. As outdoor lighting is usually supplied via an in-house power supply system, Powerline communication is not subject to

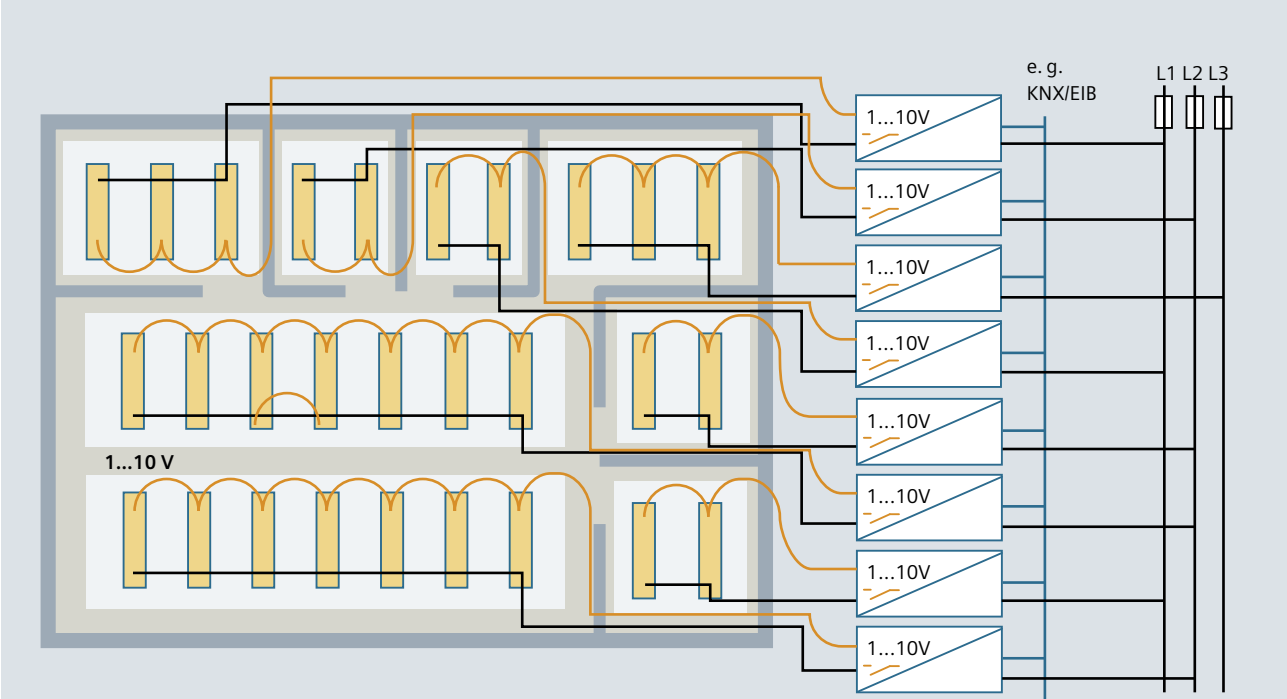

**Determination of the light groups prior to installation!**

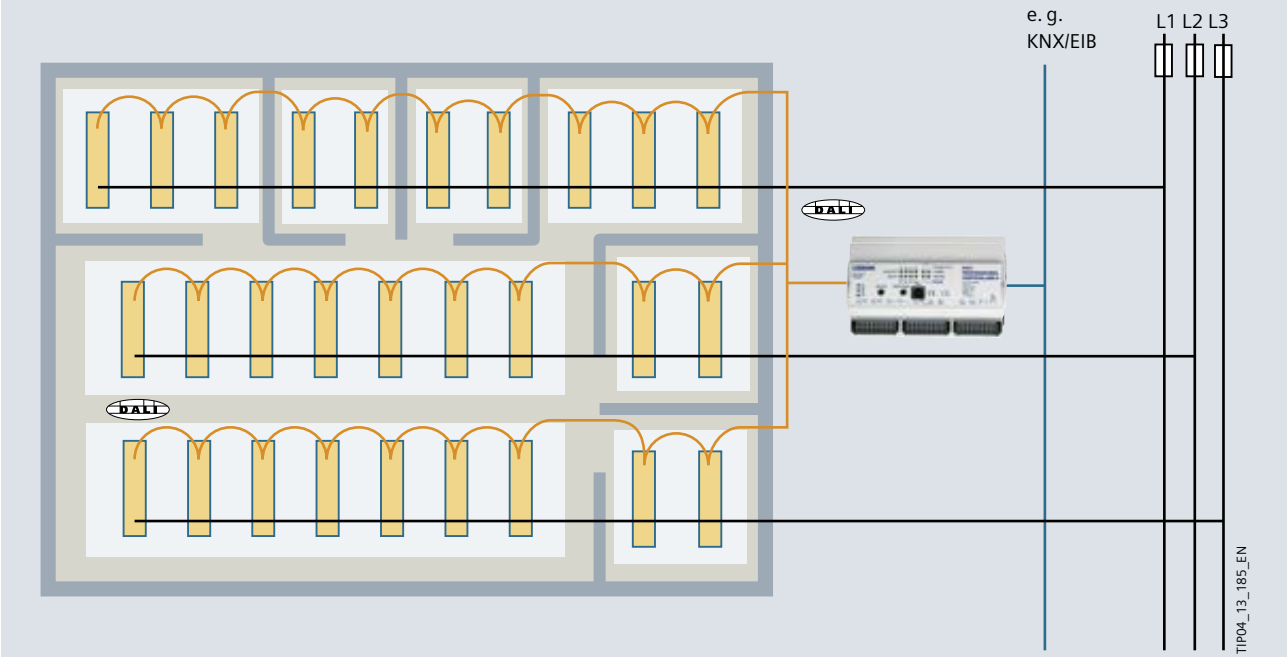





**Determination of the light groups possible after installation!  
New group allocation possible without rewiring!**

Fig. 16/11: Comparison of the system design between 1...10 V and DALI

[back to page 321](#)

any disturbances caused by other consumers or climatic influences. Moreover, it is protected against unauthorized access and is not disturbed by radio networks (WLAN), as it is cable-based. Obstacles such as buildings or trees have no influence on the signal transmission either.

Lighting management on the Internet:  
[siteco.com/en/products/lighting-management.html](http://siteco.com/en/products/lighting-management.html)

	Operating modes		
			
Energy saving by dimming	✓	✓	✓
Integration into existing installations	✓ <sup>2)</sup>	✓	✓
Flexibility to control different light points	✓		
Bidirectional communication in telemanagement systems	✓		
Autonomous dimming			✓
Use of the existing bi-power approach with conventional ballasts (half-night switching)		✓ <sup>1)</sup>	
<sup>1)</sup> In mixed installations, special precautions have to be taken when installing the luminaire <sup>2)</sup> DALI must already be available in the existing installation			

Tab. 16/6: Comparison of the 3DIM scope of functions

[back to page 321](#)

### 16.5.3 Comparison of Lighting Concepts

In the configuration and planning of lighting systems, the lighting costs are usually the decisive criterion. The basic considerations deal with the question: refurbishing or purchasing a new system?

Since nowadays the energy costs represent more than half of the total costs of a lighting system, concepts should be compared that point out significant differences with regard to the energy consumption as well as investment and maintenance costs. Generally, it is to be expected that – by using energy-efficient lighting over a longer operating life – savings can be achieved compared to existing solutions.

Apart from the selection of lamps, ballasts and luminaires, the use of lighting management systems plays an important part for usage-based planning. However, for the following comparison of different lighting concepts, only the lighting elements are considered. When planning a lighting concept, assumptions and specifications are applied for different mounting positions, illuminants and luminaires. The lighting solutions resulting from that can be compared and evaluated. For holistic system comparisons, it is essential that the quality, service life, service performance, spare parts supply, and maintenance properties of the luminaires as well as the compliance with the quality characteristics are comparable. In the following, various lighting systems for the refurbishment of an industrial hall are compared (Fig. 16/12).

The base data such as hall dimensions, working plane, operating hours, lighting conditions etc. for the determination of the lighting system are stated in Tab. 16/7. The planning requirements for the illuminance maintenance value  $\bar{E}_m$ , the maximum glare ( $UGR_L$ ), the uniformity ratio of illuminance ( $U_0$ ), and the colour rendering index

Tab. 16/7 are selected in compliance with EN 12464-1 (in particular Table 5.11.5) for the usage profile “Industrial activities and crafts – Electrical and electronic industry – rough assembly work”.

In the example, no local restriction of the visual task is assumed. Therefore, the lighting must be designed as general lighting so that the visual conditions are equally good at all places in the room. For test stations and other activities with higher visual requirements, additional lighting with workplace luminaires is required. Sufficient vertical illuminance must be ensured for workplaces intended for handling large equipment.

Possible mounting positions for the lighting systems are defined on the basis of the structural conditions. Due to the beams in the room, the light point height is 5 m, resulting in a rather wide-angle radiation characteristic (LDC) for the lighting system. The light quality is determined by the selection of the illuminant. The selection and combination

Parameter	Data for the considered example
Room geometry (L × W × H)	50 m × 30 m × 6.5 m
Reflectance values (C × W × F) (Ceiling × Walls × Floor)	70 × 50 × 20
Maintenance factor	0.67 (normal rooms and a maintenance interval of 3 years)
Working plane h	0.75 m
Operating hours per year	5,000 h/a
$\bar{E}_m$	≥ 300 lx
$UGR_L$	< 25
$U_0$	≥ 0.6
Colour rendering index	80

Tab. 16/7: System and lighting data for an industrial hall [back to page 325](#)

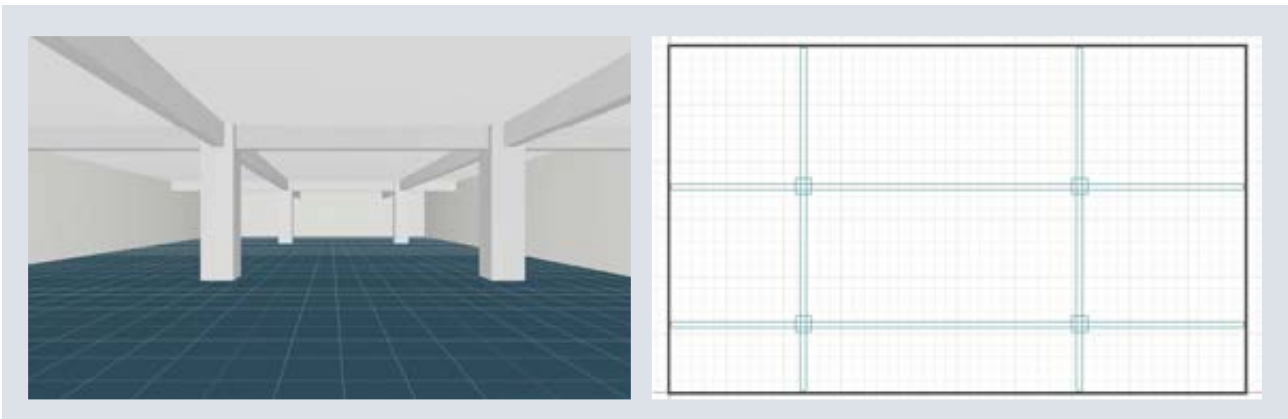

Fig. 16/12: Lighting concept finding for the refurbishment of an industrial hall (left: 3D view; right: floor plan)



of illuminants is designed to the specific system requirements (see last table in this chapter).

In the industry sector, fluorescent lamps, high intensity discharge lamps, and LED illuminants are suited for lighting. Fluorescent lamps have a high luminous efficacy, a long service life and are available in various light colours and lengths. The lamps have a uniform light distribution. Fluorescent lamps are continuously dimmable (from 100% to 1%) so that the system can be automated.

High intensity discharge lamps (metal halide lamps) have a high luminous efficacy, too, as well as very good colour rendering. In particular lamps with ceramic technology are suited for high requirements on the colour rendering and for long burning times. Lamps with ceramic technology are dimmable subject to restrictions via a special electronic ballast.

LEDs are suitable for all applications. By selecting and combining suitable LEDs, specific requirements are met. LEDs have a long service life, are highly efficient, have a high switching capability, and can be used for a wide range of operating temperatures (caution at high ambient temperatures!). LEDs have a high shock and vibration resistance, do not emit any UV and IR radiation, and are continuously dimmable (from 100% to 1% – caution: at low dimming values, they switch to pulse width modulation (PWM)!).

The selection of the required light distribution curve (in the example, wide-angle is selected) and illuminants (fluorescent lamp, high intensity discharge lamp, or LED) determines the selection of the corresponding luminaires. Generally suitable in industrial areas is strip lighting, as the applied flexible systems can easily be adapted to changes in the production flows. Luminaires and spotlights can be applied at any position on the bar with the aid of adapters.

In high halls (from heights of 6 m on), high-bay/mirror hall luminaires are an alternative. In the often dirty environments of industry and handicrafts, it is reasonable to use luminaires with a higher degree of protection. The luminaires remain clean for a longer period, which extends their service life and maintenance interval.

For the sample calculations, lighting systems with strip lighting on the basis of fluorescent lamps (T8 and T5) as well as LEDs are selected:

- SiTECO DUS strip lighting system – T26 2 × 58 W – LLB (low-loss ballast LLB, fluorescent lamp T26)  
Luminous flux 2 · 5,200 lm  
Luminaire efficiency factor 71.9%
- SiTECO Modario strip lighting system – T16 2 × 35 W – EB (electronic ballast EB, fluorescent lamp T16)

Luminous flux 2 · 3,300 lm  
Luminaire efficiency factor 93.4%

- SiTECO Modario strip lighting system – LED 70 W – EB (electronic ballast EB, LED)  
Luminous flux 6,200 lm  
Luminaire efficiency factor 100%

For these systems, first the number of luminaires required each is determined with the simplified efficiency factor method and then compared with the results of the corresponding software calculations.

### Efficiency factor method

In the simplified efficiency factor method, the data from Tab. 16/7 are used to determine the room index for direct lighting (height difference between luminaire plane and working plane):

$$k = \frac{a \cdot b}{h_N \cdot (a + b)}$$

$$k = \frac{50 \text{ m} \cdot 30 \text{ m}}{(5 \text{ m} - 0,75 \text{ m}) \cdot (50 \text{ m} + 30 \text{ m})}$$

$$k = 4,4$$

From Fig. 16/8 (in accordance with DIN V18599-4), a room efficiency factor of 100% can be read for a direct lighting with k=4.4 (in accordance with DIN V18599-4, the value is to be interpolated between 1.03 and 1.05; limitation of the room efficiency factor to 100%). Using the formula

$$n = \frac{\bar{E}_m \cdot A}{z \cdot \Phi \cdot \eta_{LB} \cdot \eta_R \cdot MF}$$

and data on the following three luminaire systems and from Tab. 16/7, the number of luminaires n is determined:

- n (DUS, 2 × 58 W T26, LLB) = 90 pieces
- n (Modario, 2 × 35 W T16, EB) = 109 pieces
- n (Modario, 70 W LED, EB) = 108 pieces

### Software-based solution

In calculation tools such as RELUX or DIALux, the room is mapped (mind the reflectance coefficients of the boundary room areas!), the area of the visual task is defined, and the corresponding reference surfaces are inserted. The luminaire type is selected in the tool's project manager and the maintenance factor is defined.

The calculation tool allows the luminaires to be distributed automatically using a quick planning feature or manually. While the simplified efficiency factor method just differentiates direct, partly/partly direct/indirect and indirect lighting, the calculation tools consider the radiation characteristics of the luminaires (Fig. 16/13).

The calculations with the software tool supply the following piece numbers:

- n (DUS, 2 × 58 W T26, LLB) = 90 pieces
- n (Modario, 2 × 35 W T16, EB) = 110 pieces
- n (Modario, 70 W LED, EB) = 105 pieces

A typical evaluation of the calculation with a software tool for the illuminances on the working plane and the associated data is given in Fig. 16/14.

The very high consistency of the results of the simplified efficiency factor method and the software tool can be explained by the simple design and homogeneous lighting effected by the selected lighting systems. Deviations result from the slight differences of the radiation characteristics and the unification for the room efficiency factor. In the software tools, light distribution curves and room reflectance coefficients are usually converted to a specific room efficiency factor for a room and the lighting system under consideration and then further employed.

**Basis for energy cost considerations**

For all calculations, the same maintenance factor was assessed. By implication, this means that the lighting systems will be maintained at different times. The variant T26 2 × 58 W after 10,000 h, the T16 solution 2 × 35 W after 18,000 h, and the LED solution after 50,000 h.

In the project, almost identical piece numbers have been calculated for the different lighting solutions. However, the maintenance time varies considerably between the variants. Additionally, attention should be paid to the specific connected loads, which generate costs in electric power distribution in proportion to the loads connected. The conventional solution with T26, 2 × 58 W achieves 9.2 W/m<sup>2</sup>, the modern variant with fluorescent lamps T16, 2 × 35 W 5.8 W/m<sup>2</sup> and the solution with LED lighting 4.9 W/m<sup>2</sup>. Thus, the LED solution involves significantly less maintenance expense and at the same time the most efficient lighting technology with the same number of pieces. Tab. 16/8 states important basic data for a system and energy cost comparison.

The data from Tab. 16/8 can be used for a calculation of profitability. The following manufacturer-based online tools provide assistance:

[siteco.com/en/planning-guide/cost-efficiency-calculator-for-indoor-applications.html](http://siteco.com/en/planning-guide/cost-efficiency-calculator-for-indoor-applications.html)

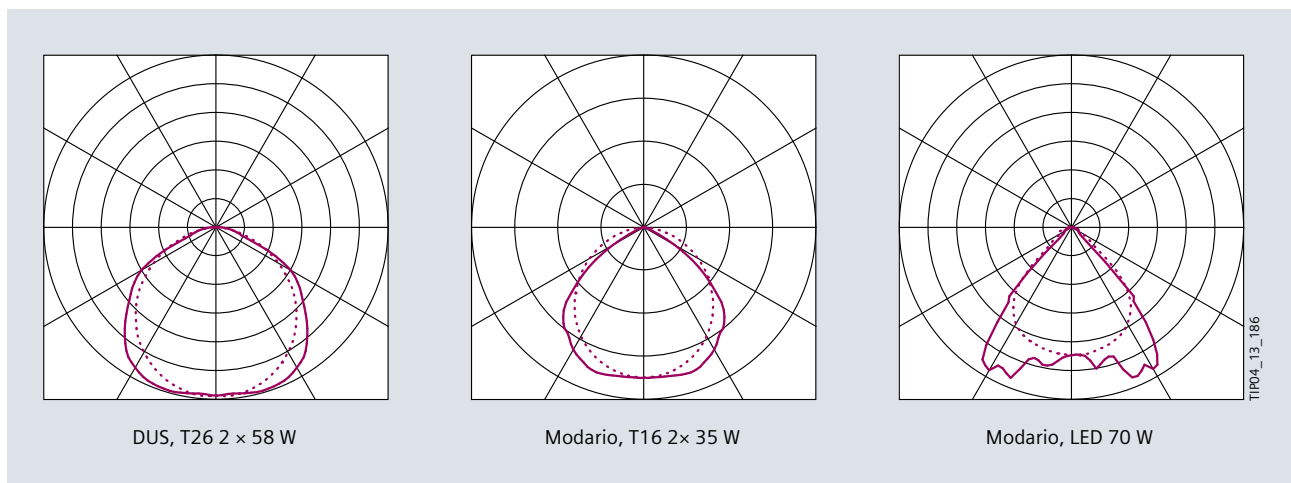

Fig. 16/13: Radiation characteristics for the three sample lighting systems

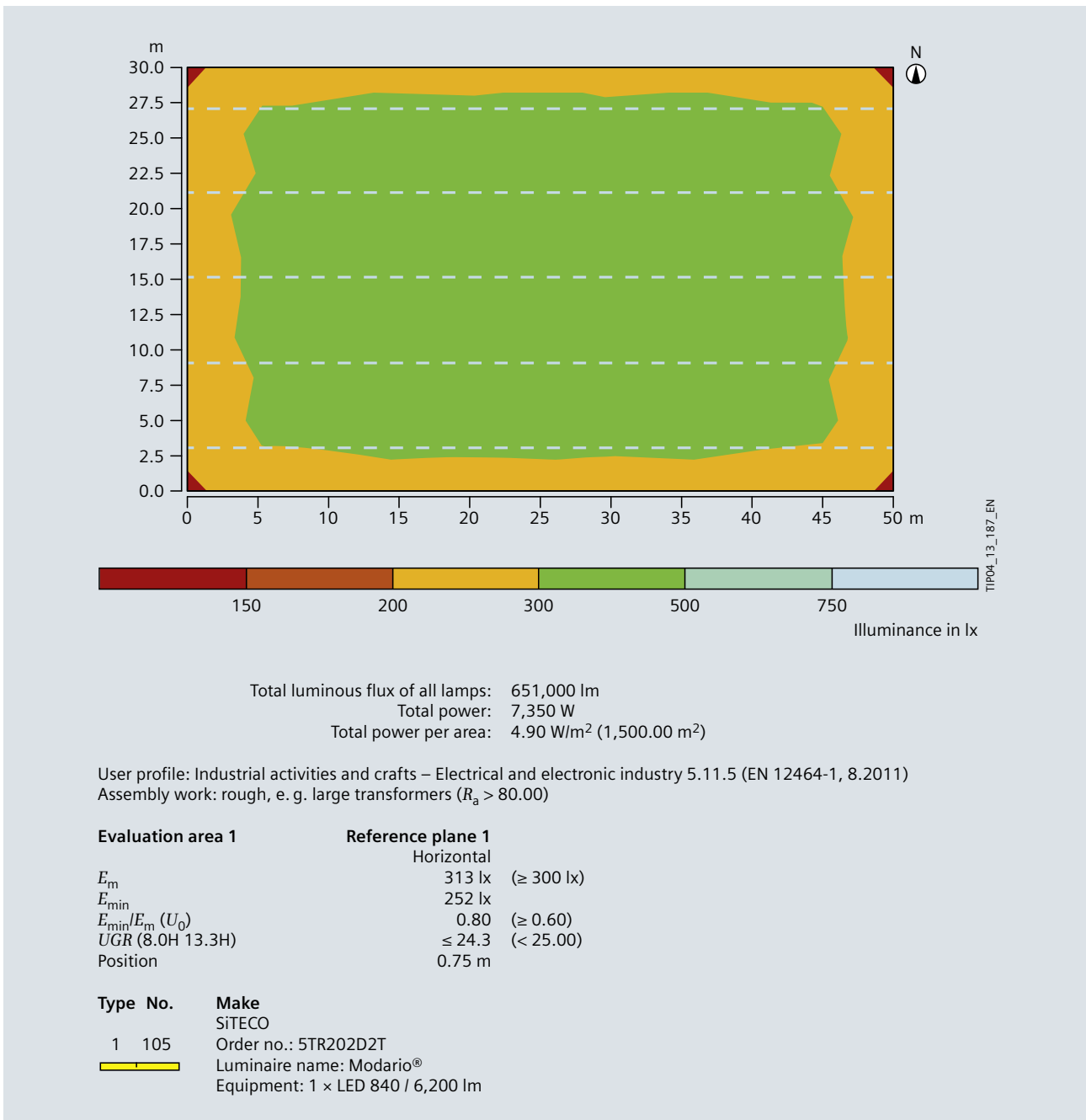

Fig. 16/14: Excerpt of the results of a software calculation for the LED lighting system

[back to page 326](#)

1

2

3

4

5

6

7

8

9

10

11

12

13

14

15

16

17

Luminaire	DUS	Modario	Modario
Designation	T26 2×58 W	T16 2×35 W	LED
Radiation characteristics	Wide-angle	Wide-angle	Wide-angle
Degree of protection	IP20	IP20	IP20
Type of lamp	T26 2×58 W	T16 2×35 W	LED
Lamps per luminaire	2	2	1
Total luminous flux of all lamps	10,400 lm	6,600 lm	6,200 lm
Efficiency factor of the luminaire	71.9%	93.4%	100%
Luminous flux of the luminaire	7,478 lm	6,164 lm	6,200 lm
Maintenance factor calculation	0.67	0.67	0.67
Illuminance	322	315	313
Uniformity	0.74	0.76	0.8
Costs (energy, maintenance)			
Power consumption of the luminaire	145 W	79 W	70 W
Total efficiency of the luminaire	52 lm/W	78 lm/W	89 lm/W
Number of luminaires in the room	95	110	105
Useful life of the system	20 a	20 a	20 a
Annual operating time	7,300 h/a	7,300 h/a	7,300 h/a
Energy costs per year	1,059 kWh/a	577 kWh/a	511 kWh/a
Maintenance cycles in the useful life	14	8	2

Tab. 16/8: Result overview for the calculations with a software tool and basic data for energy cost considerations [back to page 326](#)

## 16.6 Emergency Lighting

When planning emergency lighting, laws, guidelines, and ordinances have to be complied with. An important basis for that are the technical standards characterising the state of the art. Often, country-specific standards, provisions, and regulations have to be observed. Tab. 16/9 lists the essential legal and normative bases that are relevant to safety lighting in Germany.

Emergency lighting is requested in building law, industrial safety legislation, or rules of the German Employers' Liability Insurance Associations (BGR) etc., in case the power supply for the general artificial lighting fails. Therefore, in accordance with EN 1838, it has to be ensured in the installation phase that the emergency lighting is supplied independently of the power supply for the general artificial lighting. In the dimensioning of the emergency lighting, distinctions are made with regard to the intended use (Fig. 16/15). Emergency lighting therefore sets special requirements, which often involve costs and specific space assignments, so that bearing these requirements in mind is usually indispensable even in basic planning considerations. The planner and his client should exchange ideas early on a building layout that includes emergency escape routes and the fitting of emergency lighting systems.

In order to meet the safety objectives such as the chance to leave a place safely, to avoid the outbreak of panic, and to ensure the safety of potentially hazardous workplaces, safety lighting has to maintain the following functions during a failure of the normal power supply:

- Lighting or back-lighting of the safety signs for emergency escape routes
- Lighting of emergency escape routes

- Lighting of fire fighting and alarm stations
- Facilitating rescue actions

Ordinances and provisions as to safety lighting apply to locations such as:

- Emergency escape routes at workplaces
- Workplaces involving special hazards
- Guest accommodation facilities, homes
- Shops, restaurants
- Places of public assembly, theatres, stages, cinemas, exhibition halls, as well as temporary structures intended for public assembly
- Basement and multi-storey car parks
- High-rise buildings
- Airports, railway stations
- Schools

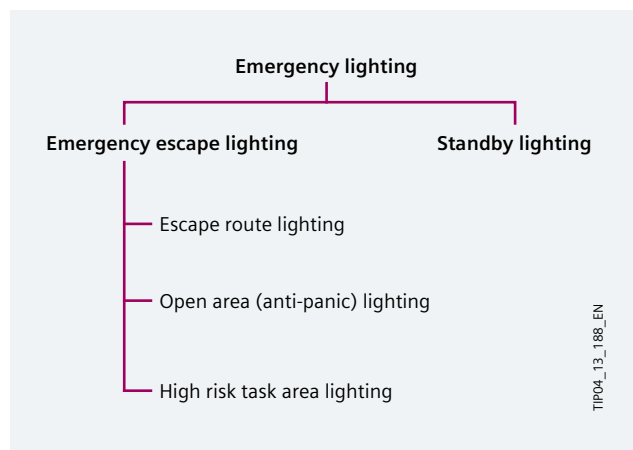

Fig. 16/15: Types of emergency lighting in accordance with EN 1838

Requirements	Installation	Devices	Inspection / maintenance
National building law ASchG / ArbStättV / ASR MBO / LBO BGR 216 / BGR 131-1 and -2 EN 12193 EN 12464-1 and -2 BGR / GUV-R 108	ISO 23601 Standard series IEC 60364 (VDE 0100) IEC 60364-5-56 (VDE 0100-560) IEC 60364-7-718 (VDE 0100-718) EN 50172 (VDE 0108-100:2005) VDE V 0108-100 Standard series EN 50272 (VDE 0510) EN 1838 EN 15193 MLAR EltBauVo	EN 50171 (VDE 0558-508) IEC 60896-21 IEC 60598-2-22 (VDE 0711-2-22) DIN 4844-1 and -2 Standard series ISO 3864 Standard series IEC 61347 (VDE 0712) EMVG	ArbStättV MPrüfVo IEC 60364-6 (VDE 0100-600) IEC 60364-7-718 (VDE 0100-718) EN 50172 (VDE 0108-100:2005) VDE V 0108-100 EN 50171 (VDE 0558-508) Standard series EN 50272 (VDE 0510) Manufacturer's instructions BetrSichV BGV A3

Tab. 16/9: Statutory bases, standards and guidelines around safety lighting

Physical structures for the gathering of people	Illuminance (lx)	Max. switch-over time (s)	Rated operating time of the power source for safety purposes (h)	Continually operated illuminated or back-lit safety sign	Central power supply system (CPS)	Power supply system with power limitation (LPS)	Self-contained system	Power generator, uninterruptible (0 s)	Power generator, short-time interruption (≤ 0.5 s)	Power generator, mid-scale interruption (≤ 15 s)	Specially backed power system
Places of public assembly and such involving temporary structures, theatres, cinemas, exhibition halls, shops, restaurants, airports, railway stations <sup>1)</sup>	b)	1	3	x	x	x	x	x	x	-	-
Stages	3	1	3	x	x	x	x	x	x	-	-
Guest accommodation facilities, homes	b)	15 <sup>a)</sup>	8 <sup>e)</sup>	x	x	x	x	x	x	x	-
Schools	b)	15 <sup>a)</sup>	3	x	x	x	x	x	x	x	-
Basement and multi-storey car parks	b)	15 <sup>a)</sup>	3	x	x	x	x	x	x	x	-
High-rise buildings	b)	15	3 <sup>d)</sup>	x	x	x	x	x	x	x	-
Emergency escape routes at workplaces	b)	15		x	x	x	x	x	x	x	x
Workplaces involving special hazards	b)	0.5	c)	x	x	x	x	x	x	-	x

<sup>a)</sup> Depending on the panic risk from 1 s to 15 s and risk assessment.  
<sup>b)</sup> Illuminance of safety lighting in accordance with EN 1838.  
<sup>c)</sup> The period entailing danger for people.  
<sup>d)</sup> 8 h for residential buildings if the lighting is not switched as detailed under <sup>g)</sup>.  
<sup>e)</sup> 3 h are sufficient if the lighting is switched as detailed under <sup>g)</sup>.  
<sup>f)</sup> 1 h is also permissible for overground areas in railway stations depending on the evacuation concept.  
<sup>g)</sup> Rated operating time of 3 h if the safety lighting is continually operated together with the general lighting; it must be possible to identify at least one light switch as local switching device from any place even if the general lighting fails. Safety lighting is automatically switched off after a settable time if it is supplied from a power source for safety purposes.

x = permissible    - = not permissible

**Tab. 16/10: Safety lighting requirements of physical structures for the gathering of people based on the pre-standard VDE V 0108-100:2010 (Note: EN 50172:2004 correlates with VDE 0108-100:2005 and deviates from the newer pre-standard VDE V 0108-100:2010 in some parts)**

VDE V 0108-100 states the requirements placed on safety lighting for the different rooms and buildings (see also Tab. 16/10). Standby lighting is used to enable people to continue economically and/or technically important work during the failure of normal lighting. For this reason, the provisions applicable to safety lighting have to be fulfilled and the wattage of standby lighting has to correspond to that of normal lighting. At a low illuminance level, safety lighting may only be used for shutting down or terminating work processes.

The German pre-standard VDE V 0108-100, which is based on the older European standard EN 50172 for safety lighting systems, requires the following for electrical installations, circuits, control and bus systems among other things:

- Along the course of emergency escape routes, two or more lamps must be installed in every area for reasons of system integrity
- If more than one safety light is required in a room, the number of luminaires must alternate between two circuits. A maximum of 20 luminaires may be connected into one circuit. Their load may not exceed 60% of the rated current of the overcurrent protection device
- The following types of power sources can be distinguished:

- self-contained systems
- central power supply systems (CPS)
- power supply systems with power limitation (LPS)
- power generators with defined interruption time in seconds
- specially backed power system
- A distinction is made between permanent lights and standby lights. Safety lights may only be operated together with the general lighting in rooms and on emergency escape routes that
  - can be sufficiently illuminated with daylight
  - cannot be fully darkened during normal operation
  - are not permanently occupied
- Control and bus systems for safety lighting have to be independent of the control and bus systems for normal lighting

Boundary conditions for planning that are dependent on the building are specified in standards. A safety lighting system consists of the following components: safety power source, distributors, monitoring devices, cabling, luminaires, and rescue signs. First, the power source type should be determined as the core element of the safety supply. The systems listed below have specific advantages (+) and disadvantages (–):

- Central power supply system (CPS)
  - + Cost reduction due to common circuits for continuous operation, standby mode, and switched permanent light possible
  - + Central monitoring from every peripheral location possible
  - + Monitoring of individual luminaires
  - + Cost reduction due to common circuits for continuous operation, standby mode, and switched permanent light possible
  - + Low follow-up costs
  - Must be placed in F30/T30 areas (MLAR – Sample Directive on Fireproofing Requirements for Conduits and Line Systems, 2005)
  - E30 cabling required down to every fire section (MLAR)
- Power supply system with power limitation (LPS)
  - + Cost reduction due to common circuits for continuous operation, standby mode and switched permanent light possible
  - + Central monitoring from every peripheral location possible
  - + Monitoring of individual luminaires possible
  - + Cost reduction due to common circuits for continuous operation, standby mode and switched permanent light possible
  - + Low follow-up costs
  - Power and energy limitation (for example, 1,500 W for 1 h or 500 W for 3 h)

- Must be placed in F30/T30 areas (MLAR)
- E30 cabling required down to every fire section (MLAR)
- Self-contained system
  - + Low investment costs
  - + Easy retrofitting
  - + High redundancy
  - High follow-up costs due to inspections and replacement
  - Only suitable for low power outputs
  - Fitting in distributed luminaires not possible
  - Use under low temperature conditions not possible or only with external heating
  - Limited light point height (max. 5 to 8 m)
- Power generators (uninterruptible, short, mid-scale interruption)
  - + Long operating time ratings
  - + AC-capable power consumers
  - + Low follow-up costs
  - + Only for safety-relevant consumers in accordance with IEC 60364-5-56 (VDE 0100-560)
  - Monitoring of individual luminaires not possible
  - Circuit reduction not possible
  - Expensive and/or intricate construction work for tank and exhaust gas routing
- Specially backed power system (normally second system feed-in)
  - + Long operating time ratings
  - + AC-capable power consumers
  - + Low follow-up costs
  - + Only for safety-relevant consumers in accordance with IEC 60364-5-56 (VDE 0100-560)
  - Monitoring of individual luminaires not possible
  - Circuit reduction not possible
  - Only permitted at workplaces

Since a second independent system feed-in is usually not available, it will be difficult in reality to obtain a specially backed power system from different supply network operators. With standby power generating sets, it is often necessary to consider long transmission lines and verify 100 percent emergency standby capability. The planning expense for factoring in other power consumers connected to the standby power generating set has to be taken into account, too.

A disadvantage of battery power for safety lighting is that self-contained luminaires become economically inefficient if more than about 15 to 25 luminaires are used. The boundary conditions for ageing-related luminaire replacement should always be looked into, too, when considering the use of self-contained luminaires.

If the building layout allows for splitting the safety lighting into fire sections, the choice could be low power systems (LPS, previously known as group battery systems). In most cases, however, a central power supply system (CPS), also known as central battery system, can be recommended.

The final circuits from the low power and central power systems to the luminaires are wired in compliance with the Sample Directive on Fireproofing Requirements for Conduits and Line Systems (MLAR) in Germany. The advantages of these systems are their relatively short cable paths and the fact that the energy required in case of a failure is available in the form of batteries very close to where the energy is consumed. It is therefore not necessary to build up and maintain intricate and costly switchgear and cable networks for standby power distribution.

With regard to functional endurance, rooms containing battery systems and distribution boards for safety power supply must comply with the requirements of MLAR 2005 and the model building code EitBauVo 01/2009. In particular, it must be ensured that the distribution boards for safety power supply are kept separate from the distribution boards for normal power supply in functional endurance class E30. This also applies in cases where these batteries are part of the main distribution circuit of the safety power

supply. In those cases, the requirements placed on battery rooms must be observed additionally.

When planning a safety lighting system, the spatial conditions (Fig. 16/16) and operational requirements should be clarified early. In this context, EN 1838 sets the following requirements: The luminaires of a safety lighting system should be fitted as follows:

- At least 2 m above the floor
- Close to every exit that is to be used in an emergency <sup>1)</sup>
- At stipulated emergency exits and safety signs <sup>1)</sup>
- Close to staircases <sup>1)</sup> so that every step is lit directly
- Close to every level change <sup>1)</sup>
- At every directional change of a corridor <sup>2)</sup>
- At every corridor junction <sup>2)</sup>
- Outside of and close to every exit <sup>1)</sup>
- Close to every first aid point <sup>1)</sup>
- Close to every fire-fighting or alarm station <sup>1)</sup>
- Close to escape equipment, call systems and safety zones for disabled persons <sup>1)</sup>

For the safety zones and call systems for disabled persons, two-way communication equipment has to be provided,

<sup>1)</sup> Usually a horizontal distance of 2 m max.  
<sup>2)</sup> All directions must be illuminated

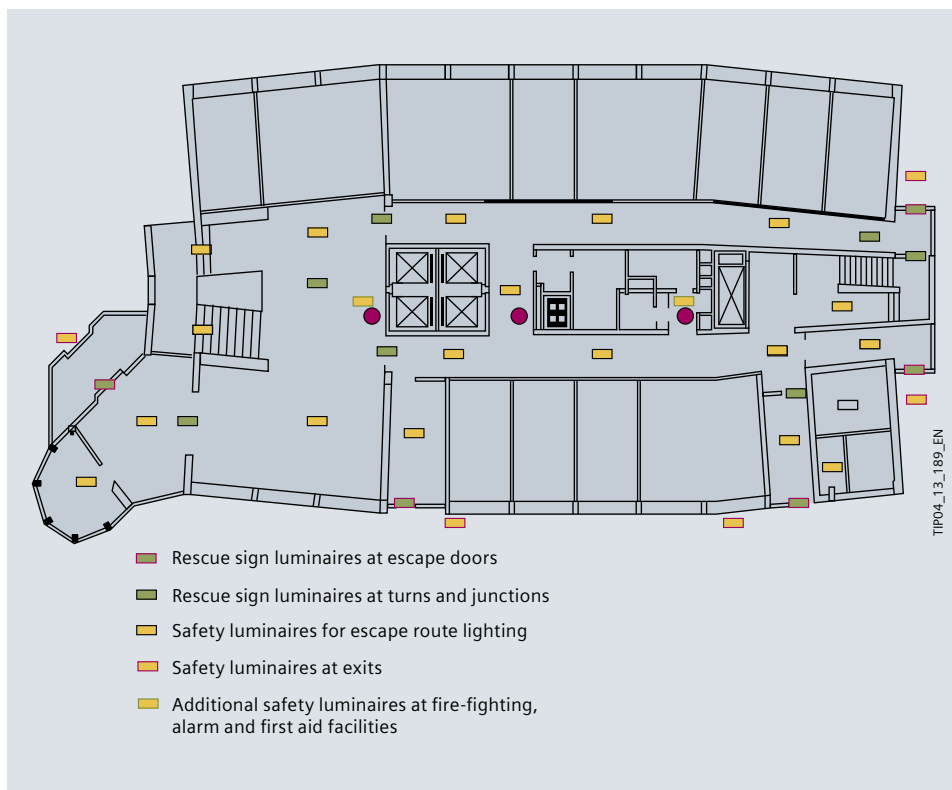

Fig. 16/16: Safety lighting plan for a whole storey in an office building



and alarm devices have to be installed in lavatories for disabled persons. In addition to this, first aid points and locations with fire fighting equipment that are not near the emergency escape route or inside the area of anti-panic lighting must be especially well lit (5 lx vertical illuminance measured on the equipment). Signs at emergency exits and exits along an emergency escape route must be lit or back-lit.

When assessing the budget for emergency lighting, you should not only look into the pure investment costs, but you should also factor in the expense for inspection, monitoring, replacement and power consumption (Fig. 16/17). Emergency lighting is to be installed, monitored, and maintained in accordance with VDE V 0108-100 or the older EN 50172. IEC 62034 (VDI 0711-400) describes the requirements on automatic testing options in case these are to be provided. Safety luminaires have to comply with IEC 60598-2-22 (VDE 0711-2-22) to reach the required lighting level. For a cost estimation, the depreciation period should be clarified.

For the subitems 'safety lighting of emergency escape routes', 'anti-panic lighting and safety lighting of workplaces involving special hazards', the requirements of EN 1838 have to be met. Tab. 16/11 gives a brief overview of the most important aspects to be considered for electrical engineering.

For an initial power estimation of the required emergency lighting system, a correlation of the installation height of the luminaires and the required power per area can be stated in the form of a straight line (Fig. 16/18). For a more detailed determination, the ratio 40 : 1 has to be adhered to for the uniformity between the maximum and minimum illuminance ( $E_{max}/E_{min}$ ) in accordance with EN 1838 along the centre line of the emergency escape route. In that, emergency escape routes broader than 2 m are to be divided into multiple strips of 2 m or equipped with anti-panic lighting. For workplaces involving special hazards, an illuminance of 15 lx (or 10% of the illuminance of the general lighting) and a ratio  $E_{max}/E_{min}$  of 10 : 1 must be adhered to.

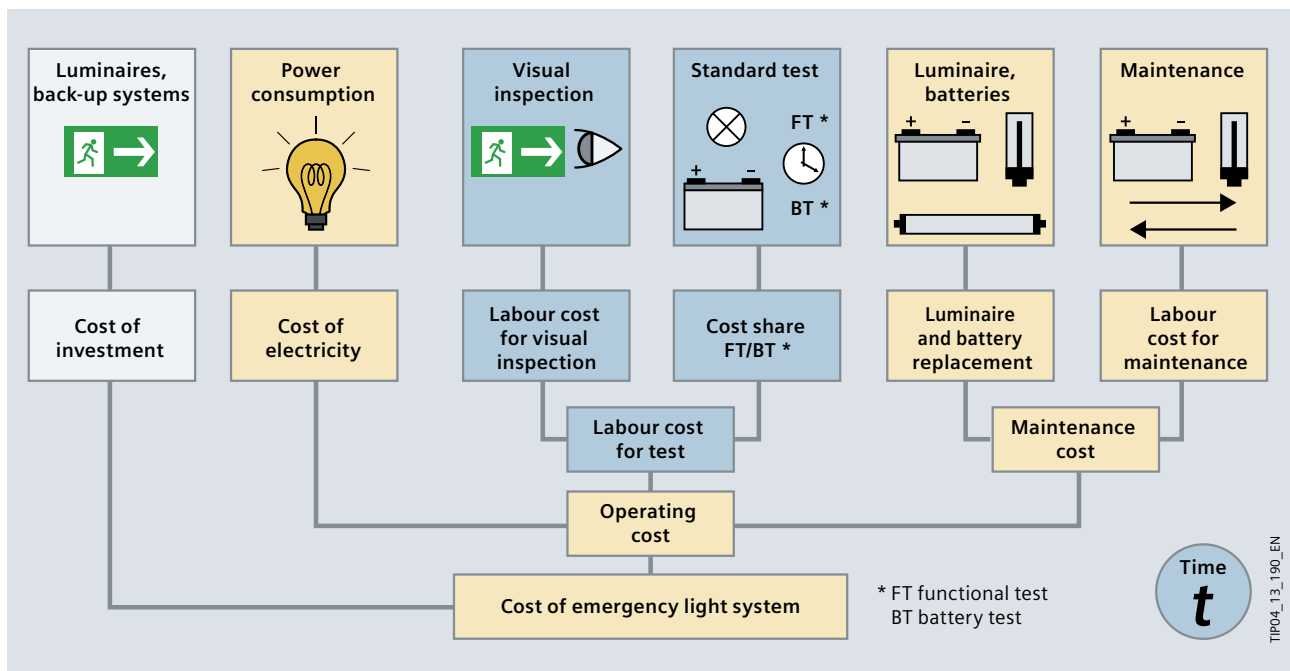

Fig. 16/17: Cost factors of emergency lighting

### Use of LEDs

In the past few years, the luminance of commercially available LEDs has been increasing considerably. With more than 100 lm/W, high-power diodes supply ten times the luminous efficacy value of the first LEDs. At the same time, LEDs provide their full light output immediately after switch-on, which is a decisive criterion in particular for emergency lighting. In the draft version of IEC 60598-2-22 (Draft VDE 0711-2-22), emergency lights with fluorescent lamps in combination with neon starters are explicitly excluded from the use in emergency lighting.

An important argument for the use of LEDs is a maximum possible service life of 50,000 hours and more. To be minded is that the degradation in the LED's semiconductor material results in a decrease of the luminous flux in the course of operation. The manufacturers declare the LED service life as the time when the luminous intensity is still 50% (sometimes the value is given for a luminous intensity of 70%) of the measured initial value. The LEDs' service life is considerably influenced by the operating and ambient temperature.

The illuminance control described before can also prolong the service life of the LED emergency lighting in continuous operation and help reducing the operating costs, as LEDs have very good dimming properties. This is because the LEDs' efficiency diminishes with the operating current increasing, so that the losses and thus the operating costs as well as the operating temperature increase. Therefore, the service life of a controlled LED is longer than that of an LED operated with permanently high current. Moreover, LEDs are virtually maintenance-free, which is an additional

advantage as to the operating costs compared to conventional lamps. Due to the low energy consumption of the LEDs, the battery volumes can be reduced (see Fig. 16/19) and the advantages of lithium ion accumulators can be utilised. Compared to conventional nickel metal hydride and nickel-cadmium batteries, lithium ion accumulators provide the following advantages:

- Small size
- No memory effect
- Low self-discharge
- Low follow-up costs (about half the follow-up costs)

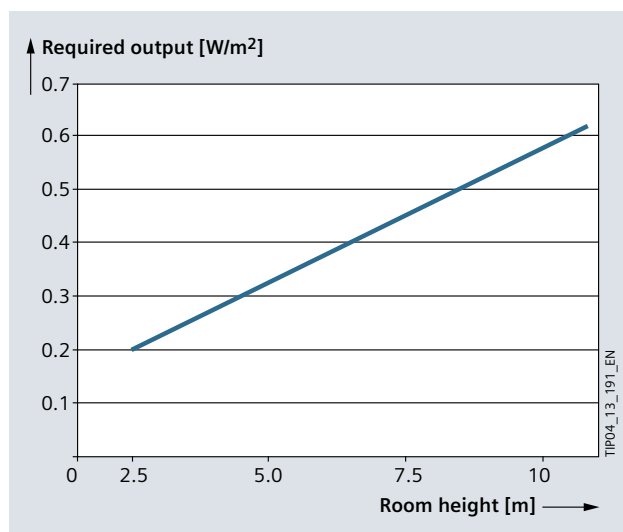

Fig. 16/18: Power estimate for emergency lighting systems with a central battery, based on experience gained with fluorescent lamps at an illuminance of 1 lx [back to page 333](#)

Requirements for ...	Safety lighting for emergency escape routes	Anti-panic lighting	Safety lighting for workplaces involving special hazards
Illuminance	In 2 m wide strips, the horizontal illuminance along the centre line of an emergency escape route must be 1 lx minimum  The middle section of the emergency escape route (at least 50% of the route width or a 1 m wide strip) must be lit with 0.5 lx minimum	The horizontal illuminance on the free floor area (except for 0.5 m wide border areas) must be 0,5 lx minimum.	The maintenance value of the illuminance on the working surface must be at least 10% of the task-related maintenance value for the illuminance or 15 lx minimum
Duration	Operating time 1 h min.	Operating time 1 h min.	Operating time corresponds at least to the hazard duration for persons at the workplace
Readiness	50% of the illuminance in 5 s, 100% of the illuminance in 60 s (for Germany 15 s)	50% of the illuminance in 5 s, 100% of the illuminance in 60 s (for Germany 15 s)	The requested luminous intensity must be either permanently given or reached within 0.5 s
Other		Required in lavatories for people with disabilities	

Tab. 16/11: Excerpt of the requirements in EN 1838 for the safety lighting of emergency escape routes, workplaces involving special hazards and for anti-panic lighting

[back to page 333](#)

The small size of the LED luminaires leaves room for the architectural integration of emergency lighting. However, optics and reflectors for the required lighting are to be considered as well as the temperature conditions in small installation spaces.

The energy demand comparison of specifically planned LED emergency lighting from CEAG with uncontrolled, conventional emergency lighting integrated into the general lighting depicted in Fig. 16/19 points out the technical development. In the example, a corridor with a length of

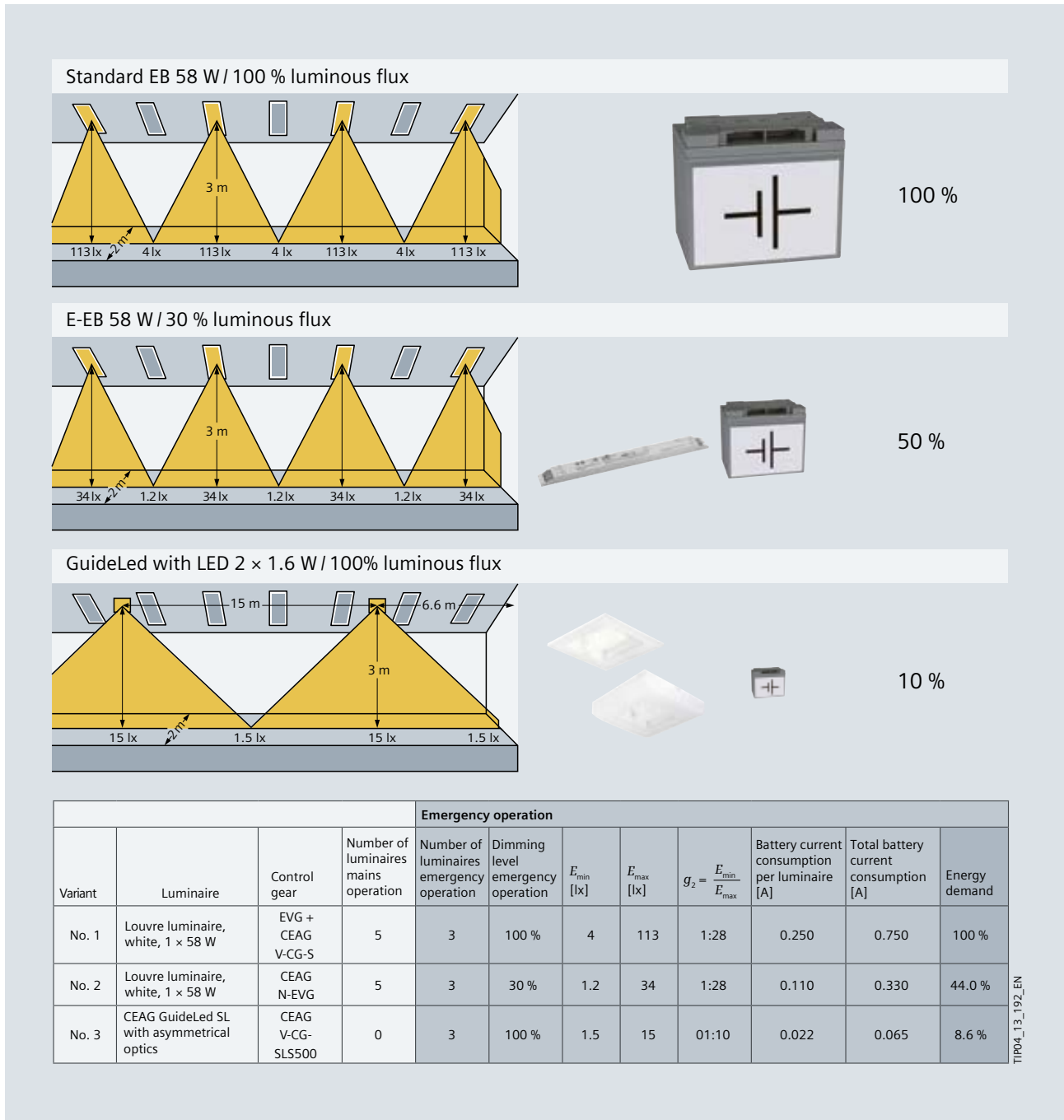

Fig. 16/19: Lighting engineering instead of battery use

[back to page 334](#)

30 m and a ceiling height of 3 m is considered. The requested illuminance for the general lighting is 100 lx. For the emergency lighting, EN 1838 requests 1 lx minimum at a uniformity

$$g_2 = E_{\max} / E_{\min} \text{ greater than } 40/1$$

As an intermediate stage, the use of controllable electronic ballasts (CEAG E-EB in Fig. 16/19) can already reduce the energy demand considerably and thus halve the size of the required accumulator.

**Functional endurance**

Self-contained luminaires do not require any cabling to be designed in functional endurance, as the luminaire is supplied by a (usually installed) battery. Thus, the installation expense can be reduced and the costs for smaller systems are lower than those for a central supply concept. The considerable additional expenditure for inspection and replacement makes more than 20 self-contained luminaires uneconomical, even if central monitoring systems are installed.

For the installation of central battery systems (including CPS and LPS) and distributors, country-specific guidelines and standards have to be observed. For Austria, the standard series ÖVE/ÖNORM E8002 defines the fire protection requirements for safety lighting systems. In Germany, EN 50272-2 (VDE 0510-2), EltBauVO, and MLAR are the basic regulations to be consulted.

The safety objective is functional endurance by separate electrical operating rooms for safety-related systems and installations in buildings stipulated by building regulations.

In case of danger, they must be easily and safely accessible from generally accessible rooms or from the outside. The doors to the electrical operating rooms must not lead directly into the staircase with the required (emergency) stairs. The emergency escape route from an electrical operating room to the exit must not be longer than 35 m. The doors must be self-closing and easy to open from inside with an emergency lever.

For central battery systems, functional endurance must be complied with in accordance with the requirements for the installations to be supplied. MLAR for Germany and ÖVE/ÖNORM E8002-1 for Austria request a functional endurance of at least 30 minutes for safety lighting systems. Therefore, the battery systems, distributors, and lines between the distributors, too, must comply with this functional endurance.

In accordance with EN 50272-2 (VDE 0510-2), the doors to central battery systems must be marked with a sign "Accumulator, battery room". EN 50272-2 (VDE 0510-2) is complied with by each of the following types of installation:

- Battery room in a building
- Separate battery areas in electrical operating rooms
- Cabinets or containers inside or outside of a building
- Device battery compartments ("combi cabinets")

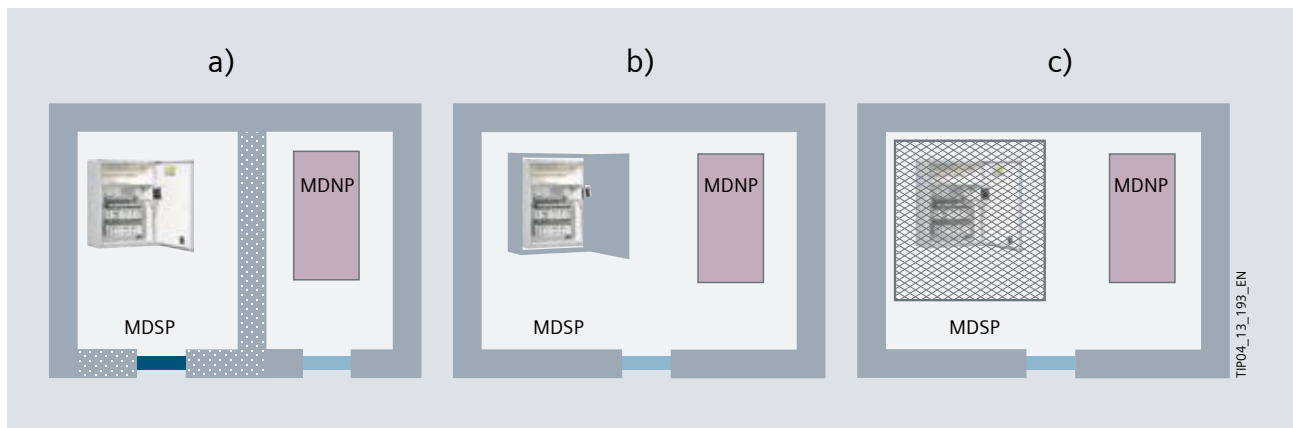

Fig. 16/20: Functional endurance for the distributors of a safety lighting system (MDSP = main distribution board for safety power supply; MDNP = main distribution board for normal power supply) back to page 337

Category	Type of lamp	Luminous efficacy <sup>5)</sup>	Luminous flux packages	Control gear	Average service life <sup>6)</sup>
Thermal radiator	Incandescent lamps (230 V) <sup>1)</sup>	10–14 lm/W	100–8,400 lm	No	1,000 h
	Tungsten halogen lamps <sup>2)</sup> (230 V–high-voltage)	10–23 lm/W	260–44,000 lm	No	2,000 h
	Tungsten halogen lamps (12/24 V–low voltage)	12–28 lm/W	55–2,300 lm	Transformer (230 V–12 V/24 V)	2,000–5,000 h
Electric discharge (low-pressure)	Fluorescent lamp (with external control gear) T8: Ø 26 mm	33–90 lm/W (with EB up to 100 lm/W)	500–6,200 lm	EB, LLB	16,000–20,000 h (XXT up to 75,000 h)
	Fluorescent lamp (with external control gear) T5: Ø 16 mm	58–114 lm/W	140–7,000 lm	EB, LLB	10,000–24,000 h (XT up to 35,000 h)
	Compact fluorescent lamp (with internal control gear)	38–75 lm/W	230–1,940 lm	EB already integrated	8,000–20,000 h
	Compact fluorescent lamp (with external control gear)	48–100 lm/W	200–6,500 lm	EB	10,000–20,000 h (XT up to 36,000 h)
	Compact fluorescent lamp	80 lm/W	6,500–12,000 lm	EB	60,000 h
	Light tube (e.g. "neon tube")	< 30 lm/W	Irrelevant, depending on gas filling and length	Depending on colour and tube length (high-voltage)	15,000 h
	Low-pressure sodium lamp	100–174 lm/W	1,800–32,000 lm	Leak transformer	30,000 h
Electric discharge (high-pressure)	High-pressure sodium lamp <sup>3)</sup>	72–150 lm/W	3,600–130,000 lm	Reactor, CB, EB with appropriate overload protection and usually an additional ignitor	12,000–30,000 h
	High-pressure mercury lamp <sup>4)</sup>	36–60 lm/W	1,800–57,000 lm	Reactor, CB	5,000–15,000 h
	Metal halide lamp (quartz and ceramic technology)	71–120 lm/W	1,700–240,000 lm	Reactor, CB, EB with appropriate overload protection	6,000–15,000 h (up to 30,000 h in exceptional cases)
Semiconductor technology <sup>9)</sup>	High-power LED	60–130 lm/W (in the future: Ø approx. 100 lm/W)	75–300 lm	Special electronic ballasts and dimmers (depending on the LED type via constant current: e.g. 350/500/700 mA, or constant voltage: e.g. 10/12/24 V)	Up to 50,000 h and more (among other things dependent on thermal management and area of application)
	Mid-power LED		Approx. 10–60 lm		
	Multi-chip LED (e.g. COB: chip on board)	Variable, depending on the type, circuit board size and number of LEDs (e.g. COB with 10,000 lm) <sup>10)</sup>			
	OLED	25–40 lm/W (in the future: 75 lm/W, 135 lm/W max.)	15–70 lm (as at 04/13, size-dependent, i.e., increasing)		

Colour rendering index (CRI)	Light colours <sup>7)</sup>	Dimming behaviour	Advantages
100	2,700 K (ww) <sup>11)</sup>	Continuously dimmable (100–0%) Dimming-dependent perceived colour shift: the stronger the dimming, the warmer the light colour	<ul style="list-style-type: none"> <li>• Low acquisition costs (except for, e.g., special lamps)</li> <li>• Perfect colour rendering</li> <li>• Uncomplicated dimming</li> <li>• Brilliance through point-type light source</li> </ul>
100	2,700–3,000 K (ww) <sup>11)</sup>		
100	2,700–3,100 K (ww) <sup>11)</sup> (exception: cold reflector lamps also up to 4,500 K)		
79–98 (the higher the CRI, the lower the luminous efficacy)	2,700–8,000 K (ww, nw, dw) <sup>11)</sup>	Continuously dimmable with EB (100–1%); below 30%, possibly increased perceived colour shift	<ul style="list-style-type: none"> <li>• High luminous efficacy</li> <li>• Long service life</li> <li>• Different light colours</li> <li>• Different lengths</li> <li>• Uniform light distribution</li> </ul>
60 greater than 90 (the higher the CRI, the lower the luminous efficacy)	2,700–8,000 K (ww, nw, dw) <sup>11)</sup>	Continuously dimmable with EB (100–1%); below 30%, possibly increased perceived colour shift	
80–89 (the higher the CRI, the lower the luminous efficacy)	2,500–4,000 K (ww, nw) <sup>11)</sup>	Rarely dimmable	<ul style="list-style-type: none"> <li>• High luminous efficacy</li> <li>• Long service life</li> <li>• Different light colours</li> </ul>
80–99 (the higher the CRI, the lower the luminous efficacy)	2,700–8,000 K (ww, nw, dw) <sup>11)</sup>	Dimmable with EB (100–1%); below 30%, possibly increased perceived colour shift	<ul style="list-style-type: none"> <li>• Great variety of sizes and forms</li> <li>• Special variants with partially extremely high switching capacities</li> </ul>
80	3,000–4,000 K	Not dimmable	<ul style="list-style-type: none"> <li>• Very long service life; high luminous efficacy</li> <li>• Flicker-free instant start</li> <li>• High luminous flux over a wide range of temperatures due to amalgam technology; low luminous flux decline</li> </ul>
–	Colour depending on gas filling	Not dimmable	<ul style="list-style-type: none"> <li>• Long service life</li> <li>• Free forming possible</li> <li>• Colourfulness</li> </ul>
–	Yellow (monochrome)	Not dimmable	<ul style="list-style-type: none"> <li>• Extremely high luminous efficacy</li> </ul>
< 25	2,000 K (yellow)	Efficiency reduction down to 50% of the rated power possible by changing the impedance if start-up was at rated power	<ul style="list-style-type: none"> <li>• Very high luminous efficacy</li> </ul>
< 60	3,200–4,200 K (ww, nw) <sup>11)</sup>	Efficiency reduction down to 50% of the rated power possible by changing the impedance if start-up was at rated power	<ul style="list-style-type: none"> <li>• Good luminous efficacy</li> </ul>
65–96	3,000–7,250 K (ww, nw, dw) <sup>11)</sup>	Only ceramic technology dimmable (with reservations) via special electronic ballast (possibly involving colour point change, shortened service life, reduced luminous efficacy)	<ul style="list-style-type: none"> <li>• High luminous efficacy</li> <li>• Very good colour rendering</li> <li>• Brilliance through point-type light source</li> </ul>
70–95, depending on the luminescent substance (the higher the CRI, the lower the luminous efficacy)	2,700–6,500 K (ww, nw, dw) <sup>11)</sup> (depending on the luminescent substance also colder possible; observe fine subdivision)	Continuously dimmable with a dimmer that is either integrated into the electronic ballast or external (100–0%) via pulse width modulation or controlled constant current; below 30% possibly increased colour shift	<ul style="list-style-type: none"> <li>• Small design allows for free forming</li> <li>• Long service life and high switching capability</li> <li>• High efficiency</li> <li>• Immediate light upon switch-on</li> <li>• Wide range of operating temperatures</li> <li>• High shock and vibration resistance</li> <li>• No UV and IR radiation (except for UV LED)</li> <li>• High colour saturation</li> <li>• Multi-LEDs allow for colour control and high CRI</li> </ul>
Up to 99 (depending on the composition and selection of the single LEDs; with conventional RGB mixture possibly lower CRI)	Continuous colour control in available spectral range <sup>12)</sup>		
80 (95 and more technically possible)	2,700–6,500 K (ww, nw, dw) <sup>11)</sup> (depending on the luminescent substance also colder possible; typical value currently 3,500 K)		
		Continuously dimmable with a dimmer that is either integrated into the electronic ballast or external (100–1%) via pulse width modulation or controlled constant current	<ul style="list-style-type: none"> <li>• Extremely thin and light</li> <li>• Production variant options: flexible, transparent or reflective</li> <li>• Immediate light upon switch-on</li> <li>• No UV and IR radiation and high CRI</li> <li>• Homogeneously radiating, anti-glare area light source</li> </ul>

Disadvantages	Suitable for
<ul style="list-style-type: none"> <li>• Poor luminous efficacy: less than 5% of the electrical energy is transformed into light</li> <li>• Maintenance-intensive due to short service life – only one light colour (ww) <sup>11)</sup></li> <li>• Poor luminous efficacy: less than 10% of the electrical energy is transformed into light (approx. 20–30% more efficient than general service lamps)</li> <li>• Maintenance-intensive due to short service life</li> <li>• Only one light colour (ww) <sup>11)</sup></li> </ul>	<ul style="list-style-type: none"> <li>• Domestic sector, hotel sector, gastronomy, museums, sales areas etc.</li> <li>• Areas in which very good colour rendering is a priority and dimmability is desired</li> </ul>
<ul style="list-style-type: none"> <li>• Temperature-dependent brightness</li> </ul>	<ul style="list-style-type: none"> <li>• Uniform light distribution, for example, for general lighting in public buildings, offices, corridors, shops, industrial facilities, tunnels</li> </ul>
<ul style="list-style-type: none"> <li>• Temperature-dependent brightness</li> <li>• Usually not dimmable</li> <li>• Switch-on delay</li> </ul>	<ul style="list-style-type: none"> <li>• Interior lighting – preferably in private areas, as energy-efficient replacement illuminant (retrofit)</li> </ul>
<ul style="list-style-type: none"> <li>• Temperature-dependent brightness</li> </ul>	<ul style="list-style-type: none"> <li>• Various, mostly public areas, indoor and outdoor</li> </ul>
<ul style="list-style-type: none"> <li>• Few sizes available</li> </ul>	<ul style="list-style-type: none"> <li>• Outdoor installations, roads, tunnels, sports venues, ships (in particular if diffused general lighting is requested and lamp replacement is difficult)</li> </ul>
<ul style="list-style-type: none"> <li>• Low luminous efficacy</li> <li>• No white light</li> <li>• Limited range of colours</li> </ul>	<ul style="list-style-type: none"> <li>• Deco, art, advertising (increasingly replaced by LEDs)</li> <li>• Integration into technical devices (e.g. scanner)</li> </ul>
<ul style="list-style-type: none"> <li>• Extremely low colour rendering</li> <li>• Slow start-up upon ignition (full luminous flux after about 12–15 min; at lower ambient temperatures correspondingly longer)</li> </ul>	<ul style="list-style-type: none"> <li>• Outdoor installations without any colour rendering demand: roads, tunnels, waterways etc.</li> </ul>
<ul style="list-style-type: none"> <li>• Extremely low colour rendering</li> <li>• Slow start-up upon ignition (full luminous flux after about 6–10 min)</li> <li>• Usually no hot restrike ignition (only after a cooling time of 0.25–15 min)</li> </ul>	<ul style="list-style-type: none"> <li>• Outdoor installations without any colour rendering demand: roads, tunnels, waterways etc.</li> </ul>
<ul style="list-style-type: none"> <li>• Low colour rendering</li> <li>• Slow start-up upon ignition (full luminous flux after about 5 min)</li> <li>• Usually no hot restrike ignition (only after a cooling time of 0.25–15 min)</li> </ul>	<ul style="list-style-type: none"> <li>• Outdoor installations with low colour rendering demand: e.g. roads, industry, squares, parks, pedestrian zones, halls</li> </ul>
<ul style="list-style-type: none"> <li>• Slow start-up upon ignition (full luminous flux after about 1–5 min); usually no hot restrike ignition (cooling time 0.25–15 min); not dimmable or only to a limited extent; filling-dependent colour difference, in particular with quartz technology (green/red cast)</li> </ul>	<ul style="list-style-type: none"> <li>• High colour rendering demand and long burning times – in particular with ceramic technology: e.g. sale, halls, architectural lighting</li> </ul>
<ul style="list-style-type: none"> <li>• Temperature management urgently required</li> <li>• Operating temperature determines service life, efficiency, light colour etc.</li> <li>• Colour drift in the border area of the light cone</li> <li>• Possibly multiple shadows due to addition of the small LEDs (depending on the luminaire design and optics)</li> <li>• Relatively high acquisition costs</li> <li>• Electromagnetic susceptibility</li> <li>• Manufacturer-specific circuit boards and connectors: lack of standards</li> </ul>	<ul style="list-style-type: none"> <li>• Suitable for all applications</li> <li>• By selecting and combining suitable LEDs, specific requirements can be met</li> </ul>
<ul style="list-style-type: none"> <li>• Manufacturer-specific and limited sizes (currently 110 × 110 mm max.)</li> <li>• Limited availability of forms and connectors: no standards</li> <li>• Diffuse radiation, therefore no light deflexion possible</li> <li>• High acquisition costs, high "lm/W" price</li> </ul>	<ul style="list-style-type: none"> <li>• Decorative lighting (light sculptures, design luminaires) and integrated into technical devices (e.g. mobile phone)</li> <li>• Medium-term: automobile integration</li> <li>• General lighting: office, sale, hospitality</li> </ul>

Not suitable for	To be observed for initial commissioning, operation and disposal <sup>8)</sup>	
<ul style="list-style-type: none"> <li>• Areas in which energy efficiency and operating costs are important and maintenance (lamp replacement) is difficult</li> </ul>	<ul style="list-style-type: none"> <li>• Immediately usable with full luminous flux</li> <li>• Protection against humidity because of the risk of corrosion</li> <li>• Immediately usable with full luminous flux</li> <li>• To be handled with gloves (among other things, to prevent corrosion of the glass)</li> <li>• Protection against humidity because of the risk of corrosion</li> </ul>	<ol style="list-style-type: none"> <li>1) Prohibited by the EU since 09/2011 and 09/2012 respectively (with a few exceptions for special lamps)</li> <li>2) Partially prohibited by the EU since 09/2011 and as of 09/2015 respectively; not affected: energy efficiency class C, halogen eco clear and special lamps</li> </ol>
<ul style="list-style-type: none"> <li>• Cold (e.g. basement) or overheated environment (e.g. due to too small luminaire housings) because of luminous flux decline</li> <li>• Accentuation through size of the light-emitting area (length)</li> </ul>	<ul style="list-style-type: none"> <li>• Recommended warm-up time for initial commissioning, not dimmed: 100 h</li> <li>• Optimal operating temperature (for maximum luminous flux) for T5 about 35 °C, for T8 about 25 °C (exception: e.g. amalgam filling)</li> <li>• Vertical mounting with ColdSpot downward, horizontal mounting for multi-flame luminaires with ColdSpot on the right</li> <li>• Protection against humidity because of the risk of corrosion</li> <li>• Disposal as hazardous waste in acc. with WEEE <sup>13)</sup>, among other things because of the mercury content (Internet: lightcycle.de)</li> </ul>	<ol style="list-style-type: none"> <li>3) Partially prohibited by the EU since 04/2011 and 04/2014 respectively (products with increased efficiency and service life still available)</li> <li>4) Prohibited by the EU as of 09/2014</li> </ol>
<ul style="list-style-type: none"> <li>• Cold (e.g., basement) or overheated environment (e.g., due to too small luminaire housings) because of luminous flux decline</li> </ul>	<ul style="list-style-type: none"> <li>• Recommended warm-up time for initial commissioning, not dimmed: 100 h</li> <li>• Optimal operating temperature (for max. luminous flux) depending on design and filling (observe manufacturer's instructions)</li> <li>• Protection against humidity because of the risk of corrosion</li> <li>• Disposal as hazardous waste in acc. with WEEE <sup>13)</sup>, among other things because of the mercury content (Internet: lightcycle.de)</li> </ul>	<ol style="list-style-type: none"> <li>5) Luminous efficacy refers to the lamp power, not to the system power; for the system power, further losses are to be expected due to the housing and technology. In exceptional cases (for example, at optimal operating temperature), the luminous efficacy may increase.</li> </ol>
<ul style="list-style-type: none"> <li>• Due to diffused light distribution, no powerful, brilliant light for accentuation</li> </ul>	<ul style="list-style-type: none"> <li>• Recommended warm-up time for initial commissioning, not dimmed: 100 h</li> <li>• Disposal as hazardous waste in acc. with WEEE <sup>13)</sup>, among other things because of the mercury content (Internet: lightcycle.de)</li> </ul>	<ol style="list-style-type: none"> <li>6) For thermal radiators and electric discharge, the average service life corresponds to 50% failure in a defined batch; for LEDs, the value has not been finally defined yet: for example, in the case of a luminous flux decline to 70%</li> </ol>
<ul style="list-style-type: none"> <li>• General lighting</li> </ul>	<ul style="list-style-type: none"> <li>• Protection against humidity because of the risk of corrosion</li> <li>• The manufacturer's disposal instructions are to be observed</li> </ul>	
<ul style="list-style-type: none"> <li>• Frequent or short switch-on and -off</li> <li>• Required light immediately after switch-on</li> </ul>	<ul style="list-style-type: none"> <li>• Protection against humidity because of the risk of corrosion</li> <li>• Disposal as hazardous waste in acc. with WEEE <sup>13)</sup>, among other things because of the sodium content (Internet: lightcycle.de)</li> </ul>	<ol style="list-style-type: none"> <li>7) By stating defined areas, strongly differing colour impressions may be effected with identical colour specifications – in particular when mixing different illuminant types!</li> </ol>
<ul style="list-style-type: none"> <li>• Frequent or short switch-on and -off</li> <li>• Required light immediately after switch-on</li> </ul>	<ul style="list-style-type: none"> <li>• To be handled with gloves (among other things, to prevent corrosion of the glass)</li> <li>• Protection against humidity because of the risk of corrosion</li> <li>• Short-term operation and frequent switching shortens the service life</li> <li>• Disposal as hazardous waste in acc. with WEEE <sup>13)</sup>, among other things because of the mercury content (Internet: lightcycle.de)</li> </ul>	<ol style="list-style-type: none"> <li>8) Operating and disposal instructions are selected to exemplify the subject matter for those interested in planning: they make no claim to be complete and serve for orientation only; the manufacturer's product-specific instructions have to be observed.</li> </ol>
<ul style="list-style-type: none"> <li>• Colour rendering demands</li> <li>• Frequent or short switch-on and -off</li> <li>• Required light immediately after switch-on</li> </ul>	<ul style="list-style-type: none"> <li>• To be handled with gloves (among other things, to prevent corrosion of the glass)</li> <li>• Protection against humidity because of the risk of corrosion</li> <li>• Due to overpressure in operation to be operated in closed luminaires only (with only a few exceptions)</li> <li>• Short-term operation and frequent switching shortens the service life</li> <li>• Disposal as hazardous waste in acc. with WEEE <sup>13)</sup>, among other things because of the mercury content (Internet: lightcycle.de)</li> </ul>	<ol style="list-style-type: none"> <li>9) Due to the rapid development of the semiconductor technology, the data may change within brief intervals; in particular with regard to luminous efficacy and luminous flux</li> </ol>
<ul style="list-style-type: none"> <li>• Frequent or short switch-on and -off (e.g., in corridors)</li> <li>• Required light immediately after switch-on</li> </ul>	<ul style="list-style-type: none"> <li>• To be handled with gloves (among other things, to prevent corrosion of the glass)</li> <li>• Protection against humidity because of the risk of corrosion</li> <li>• Due to overpressure in operation to be operated in closed luminaires only (with only a few exceptions)</li> <li>• Short-term operation and frequent switching shortens the service life</li> <li>• Disposal as hazardous waste in acc. with WEEE <sup>13)</sup>, among other things because of the mercury content (Internet: lightcycle.de)</li> </ul>	<ol style="list-style-type: none"> <li>10) Consider thermal management!</li> <li>11) ww = warm white, nw = neutral white, dw = daylight white</li> </ol>
<ul style="list-style-type: none"> <li>• High ambient temperatures and if aggressive gases arise (shortening of the service life)</li> <li>• Focus on low acquisition costs</li> </ul>	<ul style="list-style-type: none"> <li>• Protection against electrostatic discharge</li> <li>• Do not touch LED to avoid damage</li> <li>• Protection against humidity because of the risk of corrosion</li> <li>• General rule: the lower the temperature at the LED, the higher the luminous efficacy/system output and the longer the service life</li> <li>• Disposal as hazardous waste in acc. with WEEE <sup>13)</sup>, among other things because of the arsenic content (Internet: lightcycle.de)</li> </ul>	<ol style="list-style-type: none"> <li>12) Colour range depending on the composition of the LED; for colour stabilisation, a colour sensor is required; a conventional RGB mixture might lead to an undesired colour cast</li> <li>13) The WEEE Directive 2002/96/EC of the European Parliament of 2003 on waste of electrical and electronic equipment is to contribute to the avoidance and environmentally sound disposal of electronic scrap and was transposed into national laws (e.g. ElektroG of 2005 in Germany)</li> </ol>
<ul style="list-style-type: none"> <li>• Powerful, brilliant light for accentuation because of diffused, wide-area light distribution</li> <li>• Not suitable yet for general lighting with the required high illuminances</li> </ul>	<ul style="list-style-type: none"> <li>• To be handled with gloves to prevent damaging and pollution of the glass</li> <li>• Protection against humidity because of the risk of corrosion of the contacts</li> <li>• The manufacturer's disposal instructions are to be observed</li> </ul>	



- 1
- 2
- 3
- 4
- 5
- 6
- 7
- 8
- 9
- 10
- 11
- 12
- 13
- 14
- 15
- 16
- 17







In accordance with MLAR, the distribution boards in a safety lighting system with fire-retardant components made of non-combustible materials must be separated from corridors and emergency staircases and rooms between emergency staircases and exits to the outside.

Fire-retardant covers with circumferential seals must close openings. The following alternatives are possible with regard to the compliance with the functional endurance:

- Placement in separate rooms that are fire-retardant in acc. with E30 (DIN 4102-12; outer walls need not be fire-retardant); except for the doors, non-combustible materials are to be used (Fig. 16/20 a)
- Installation in fire-retardant housings in acc. with E30 (Fig. 16/20 b)
- Use of fire-retardant components (non-combustible materials) and covers for the enclosures of the distribution boards (Fig. 16/20 c)
  - a) Fire-retardant room (except for outer walls)
  - b) Fire-retardant housing
  - c) Fire-retardant enclosure

The floor space of each fire section is to be limited to 1,600 m<sup>2</sup> at most. The functional endurance requirement also applies to lines from the main distribution board and for sub-distribution boards in a safety lighting system that supply fire sections larger than 1,600 m<sup>2</sup>, as pointed out in Fig. 16/21. In modern systems, a rising main with functional endurance E30 is sufficient, as E30 distribution boards allow for a distributed system of sub-distribution boards (SDSP). To comply with the functional endurance, the lines must either satisfy the requirements of DIN 4102-12 or they must be laid on raw ceilings under floor screed of at least 30 mm thickness or in the ground – which is not very likely for a building.

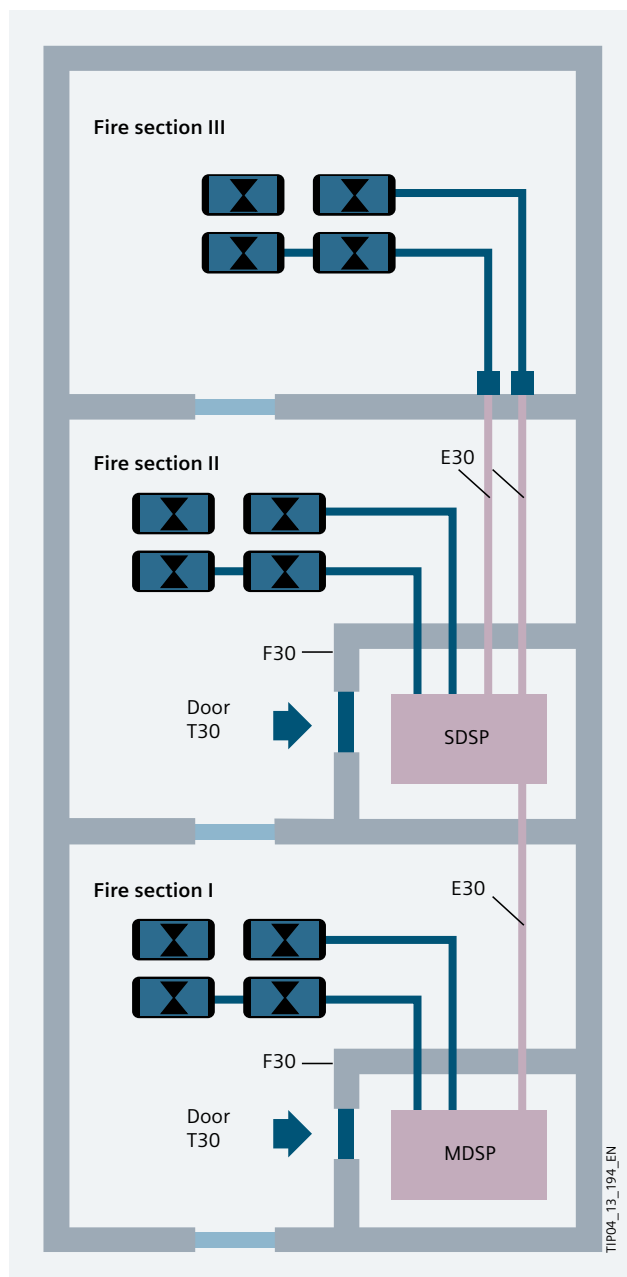

Fig. 16/21: Functional endurance for the safety lighting in individual fire sections

# Chapter 17

## Appendix

17.1 Characteristics of Grid Supply Types	346
17.2 List of Standards	347
17.3 List of Abbreviations	357
17.4 Bibliography	361
17.5 Conversion Factors and Tables	362



# 17 Appendix

## 17.1 Characteristics of Grid Supply Types

Power sources	Transformer	Generator	UPS
<b>Selection</b>	Number of power sources and power output corresponding to the power required for normal power supply	Number of power sources and power output corresponding to the total load which must be supplied if the transformers do not supply power	Number of power sources, power output and energy dependent on the time for provision of independent power supply and the total load supplied by the UPS
<b>Requirements</b>	<ul style="list-style-type: none"> <li>• High reliability of supply</li> <li>• Overload capability</li> <li>• Low power loss</li> <li>• Low noise</li> <li>• No restrictions as to installation</li> <li>• Compliance with the environment, climate and fire safety categories</li> </ul>	<ul style="list-style-type: none"> <li>• covering the energy demand for standby power supply</li> <li>• For turbocharger motors: load transfer in steps</li> <li>• Availability of sufficient continuous short-circuit power to ensure disconnect conditions</li> </ul>	<ul style="list-style-type: none"> <li>• Stable output voltage</li> <li>• Availability of sufficient continuous short-circuit power to ensure disconnect conditions</li> <li>• Low-maintenance buffer batteries for power supply, compliance with noise level limits</li> <li>• Low harmonic load for the upstream network</li> </ul>
<b>Nominal current</b>	$I_N = \frac{S_N}{\sqrt{3} \cdot U_N}$	$I_N = \frac{S_N}{\sqrt{3} \cdot U_N}$	$I_N = \frac{S_N}{\sqrt{3} \cdot U_N}$
<b>Short-circuit currents</b>	<ul style="list-style-type: none"> <li>• Sustained short-circuit current 3-phase:</li> </ul> $I_{K3} = \frac{I_N \cdot 100 \%}{U_K}$	<ul style="list-style-type: none"> <li>• Sustained short-circuit current 3-phase:</li> </ul> $I_{K3,D} \approx 3 \cdot I_N$	<ul style="list-style-type: none"> <li>• Sustained short-circuit current 3-phase:</li> </ul> $I_{K3} \approx 2.1 \cdot I_N \text{ (for 0.02 s)}$ $I_{K3} \approx 1.5 \cdot I_N \text{ (for 0.02 – 5 s)}$
	<ul style="list-style-type: none"> <li>• Sustained short-circuit current 2-phase:</li> </ul> $I_{K2} \approx I_{K3} \cdot \frac{\sqrt{3}}{2}$		
	<ul style="list-style-type: none"> <li>• Sustained short-circuit current 1-phase:</li> </ul> $I_{K1} \approx I_{K3}$	<ul style="list-style-type: none"> <li>• Sustained short-circuit current 1-phase:</li> </ul> $I_{K1,D} \approx 5 \cdot I_N$	<ul style="list-style-type: none"> <li>• Sustained short-circuit current 1-phase:</li> </ul> $I_{K1} \approx 3 \cdot I_N \text{ (for 0.02 s)}$ $I_{K1} \approx 1.5 \cdot I_N \text{ (for 0.02 – 5 s)}$
		<ul style="list-style-type: none"> <li>• Initial short-circuit alternating current:</li> </ul> $I_K'' = \frac{I_N \cdot 100 \%}{\chi_d''}$	
<b>Advantages</b>	<ul style="list-style-type: none"> <li>• High transmission capacities</li> <li>• Stable short-circuit currents</li> <li>• Electrical isolation</li> </ul>	<ul style="list-style-type: none"> <li>• Distributed availability</li> <li>• Self-contained power supply</li> </ul>	<ul style="list-style-type: none"> <li>• Low losses</li> <li>• Voltage stability</li> <li>• Electrical isolation</li> </ul>
<b>Disadvantages</b>	<ul style="list-style-type: none"> <li>• High inrush currents</li> <li>• Dependency on the public grid</li> </ul>	<ul style="list-style-type: none"> <li>• Grid instability in case of power fluctuations</li> <li>• Low short-circuit currents</li> </ul>	<ul style="list-style-type: none"> <li>• Very low short-circuit currents</li> </ul>
<small><math>I_N</math> Nominal current, <math>U_N</math> Nominal voltage, <math>U_K</math> Rated short-circuit voltage, <math>S_N</math> Nominal apparent power</small>			

## 17.2 List of Standards

International	Germany	German title	English title
1194/2012/EU		Verordnung der Europäischen Kommission zur Durchführung der Richtlinie 2009/125/EG hinsichtlich Lampen mit gebündeltem Licht, LED-Lampen und zugehörigen Geräten	Commission regulation (EU) implementing Directive 2009/125/EC of the European Parliament and of the Council with regard to ecodesign requirements for directional lamps, light emitting diode lamps and related equipment
1228/2003/EG		EG-Verordnung über die Netzzugangsbedingungen für den grenzüberschreitenden Stromhandel	EC-regulation on conditions for access to the network for cross-border exchanges in electricity
2002/91/EG		EG-Richtlinie über die Gesamtenergieeffizienz von Gebäuden	EC-directive on measuring instruments
2003/54/EG		EG-Richtlinie über gemeinsame Vorschriften für den Elektrizitätsbinnenmarkt und zur Aufhebung der Richtlinie 96/92/EG	EC Directive concerning common rules for the internal market in electricity and repealing Directive 96/92/EC
2004/22/EG		EG-Richtlinie über Messgeräte	EC Directive on Measuring Instruments (MID)
2006/32/EG		EG-Richtlinie über Endenergieeffizienz und Energiedienstleistungen und zur Aufhebung der Richtlinie 93/76/EWG	EC Directive on energy end-use efficiency and energy services and repealing Council Directive 93/76/EEC
2006/42/EG		EG-Richtlinie über Maschinen und zur Änderung der Richtlinie 95/16/EG	EC-directive on machinery, and amending Directive 95/16/EC
2014/35/EU		EU-Richtlinie zur Harmonisierung der Rechtsvorschriften der Mitgliedstaaten über die Bereitstellung elektrischer Betriebsmittel zur Verwendung innerhalb bestimmter Spannungen („Niederspannungsrichtlinie“)	EU-directive on the harmonisation of the laws of the Member States relating to the making available on the market of electrical equipment designed for use within certain voltage limits
2009/125/EG		EG-Richtlinie zur Schaffung eines Rahmens für die Festlegung von Anforderungen an die umweltgerechte Gestaltung energieverbrauchsrelevanter Produkte	EC-directive establishing a framework for the setting of ecodesign requirements for energy-related products
2010/30/EU		EU-Richtlinie über die Angabe des Verbrauchs an Energie und anderen Ressourcen durch energieverbrauchsrelevante Produkte mittels einheitlicher Etiketten und Produktinformationen	EU-directive on the indication by labelling and standard product information of the consumption of energy and other resources by energy-related products
2010/31/EU		EU-Richtlinie über die Gesamteffizienz von Gebäuden	EU-directive on the energy performance of buildings
2012/27/EU		EU-Richtlinie zur Energieeffizienz, zur Änderung der Richtlinien 2009/125/EG und 2010/30/EU und zur Aufhebung der Richtlinien 2004/8/EG und 2006/32/EG	EU-directive on energy efficiency, amending Directives 2009/125/EC and 2010/30/EU and repealing Directives 2004/8/EC and 2006/32/EC
244/2009 + 859/2009		EG-Verordnung zur Durchführung der Richtlinie 2005/32/EG für die Anforderungen an die umweltgerechte Gestaltung von Haushaltslampen mit ungebündeltem Licht + Anforderungen an die Ultraviolettstrahlung von Haushaltslampen mit ungebündeltem Licht	EC-regulation implementing Directive 2005/32/EC with regard to ecodesign requirements for non-directional household lamps – ecodesign requirements on ultraviolet radiation of non-directional household lamps
245/2009 + 347/2010		EG-Verordnung zur Durchführung der Richtlinie 2005/32/EG für die Anforderungen an die umweltgerechte Gestaltung von Leuchtstofflampen ohne eingebautes Vorschaltgerät, Hochdruckentladungslampen sowie Vorschaltgeräte und Leuchten zu ihrem Betrieb	„EC-regulation implementing Directive 2005/32/EC with regard to ecodesign requirements for fluorescent lamps without integrated ballast, for high intensity discharge lamps, and for ballasts and luminaires able to operate such lamps“
89/391/EWG		EWG-Richtlinie über die Durchführung von Maßnahmen zur Verbesserung der Sicherheit und des Gesundheitsschutzes der Arbeitnehmer bei der Arbeit	EEC-directive on the introduction of measures to encourage improvements in the safety and health of workers at work

International	Germany	German title	English title
2009/104/EG		"EG-Richtlinie über Mindestvorschriften für Sicherheit und Gesundheitsschutz bei Benutzung von Arbeitsmitteln durch Arbeitnehmer bei der Arbeit"	EC-directive concerning the minimum safety and health requirements for the use of work equipment by workers at work
Artikel 153 EU-Vertrag (2009)		Titel X – Sozialpolitik (zum Arbeitsschutz)	Title X – Social Policy (relating to occupational safety and health)
Artikel 114 EU-Vertrag (2009)		Titel VII – Gemeinsame Regeln betreffend Wettbewerb, Steuerfragen und Angleichung der Rechtsvorschriften (zum freien Warenverkehr)	Title VII – Common Rules on Competition, Taxation and Approximation of Laws (relating to the free movement of goods)
CIE 97:2005		Leitfaden zur Wartung von elektrischen Beleuchtungsanlagen im Innenraum	Guide on the Maintenance of Indoor Electric Lighting Systems
CLC/TR 60269-5	VDE 0636-5	Niederspannungssicherungen – Teil 5: Leitfaden für die Anwendung von Niederspannungssicherungen	Low-voltage fuses – Part 5: Guidance for the application of low-voltage fuses
D-A-CH-CZ-Richtlinie		Technische Regeln zur Beurteilung von Netzrückwirkungen	Technical rules for the assessment of network disturbances
EN 12193		Licht und Beleuchtung – Sportstättenbeleuchtung	Light and lighting – Sports lighting
EN 12464-1		Licht und Beleuchtung – Beleuchtung von Arbeitsstätten – Teil 1: Arbeitsstätten in Innenräumen	Light and lighting – Lighting of work places – Part 1: Indoor work places
EN 12464-2		Licht und Beleuchtung – Beleuchtung von Arbeitsstätten – Teil 2: Arbeitsplätze im Freien	Light and lighting – Lighting of work places – Part 2: Outdoor work places
EN 12665		Licht und Beleuchtung – Grundlegende Begriffe und Kriterien für die Festlegung von Anforderungen an die Beleuchtung	Light and lighting – Basic terms and criteria for specifying lighting requirements
EN 13201		Strassenbeleuchtung (Teile 1 – 4; Entwurf Teil 5: Energieeffizienzindikatoren)	Road lighting (Parts 1 – 4; draft part 5: energy performance indicators)
EN 15193		Energetische Bewertung von Gebäuden – Energetische Anforderungen an die Beleuchtung	Energy performance of buildings – Energy requirements for lighting
EN 15232		Energieeffizienz von Gebäuden – Einfluss von Gebäudeautomation und Gebäudemanagement	Energy performance of buildings – Impact of Building Automation, Controls and Building Management
EN 1838		Angewandte Lichttechnik – Notbeleuchtung	Lighting applications – Emergency lighting
EN 50160		Merkmale der Spannung in öffentlichen Elektrizitätsversorgungsnetzen	Voltage characteristics of electricity supplied by public electricity networks
EN 50171	VDE 0558-508	Zentrale Stromversorgungssysteme	Central power supply systems
EN 50172	VDE 0108-100:2005	Sicherheitsbeleuchtungsanlagen	Emergency escape lighting systems
EN 50174-2	VDE 0800-174-2	Informationstechnik – Installation von Kommunikationsverkabelung – Teil 2: Installationsplanung und Installationspraktiken in Gebäuden	Information technology – Cabling installation – Part 2: Installation planning and practices inside buildings
EN 50272 -1	VDE 0510-1	Sicherheitsanforderungen an Batterien und Batterieanlagen – Teil 1: Allgemeine Sicherheitsinformationen	Safety requirements for secondary batteries and battery installations – Part 1: General safety information
EN 50272-2	VDE 0510-2	Sicherheitsanforderungen an Batterien und Batterieanlagen – Teil 2: Stationäre Batterien	Safety requirements for secondary batteries and battery installations – Part 2: Stationary batteries
EN 50464-1	VDE 0532-221	Ölgefüllte Drehstrom-Verteilungstransformatoren 50 Hz, 50 kVA bis 2500 kVA mit einer höchsten Spannung für Betriebsmittel bis 36 kV – Teil 1: Allgemeine Anforderungen	Three-phase oil-immersed distribution transformers 50 Hz, from 50 kVA to 2500 kVA with highest voltage for equipment not exceeding 36 kV – Part 1: General requirements
EN 50541-1	VDE 0532-241	Drehstrom-Trocken-Verteilungstransformatoren, 50 Hz, 100 bis 3150 kVA, mit einer höchsten Spannung für Betriebsmittel kleiner oder gleich 36 kV – Teil 1: Allgemeine Anforderungen	Three-phase dry-type distribution transformers 50 Hz, from 100 to 3150 kVA, with highest voltage for equipment not exceeding 36 kV – Part 1: General requirements
EN 55015	VDE 0875-15-1	Grenzwerte und Messverfahren für Funkstörereigenschaften von elektrischen Beleuchtungseinrichtungen und ähnlichen Elektrogeräten	Limits and methods of measurement of radio disturbance characteristics of electrical lighting and similar equipment



International	Germany	German title	English title
EN 61100	VDE 0389-2	Klassifikation von Isolierflüssigkeiten nach dem Brandverhalten und unteren Heizwert	Classification of insulating liquids according to fire point and net calorific value
HD 639 S1/A2	VDE 0661-10/A2	Elektrisches Installationsmaterial – Ortsveränderliche Fehlerstrom-Schutzeinrichtungen ohne eingebauten Überstromschutz für Hausinstallationen und ähnliche Anwendungen (PRCDs)	Electrical accessories – Portable residual current devices without integral overcurrent protection for household and similar use (PRCDs)
IEC 60034-1	VDE 0530-1	Drehende elektrische Maschinen – Teil 1: Bemessung und Betriebsverhalten	Rotating electrical machines – Part 1: Rating and performance
IEC 60038	VDE 0175-1	IEC Normspannungen	IEC standard voltages
IEC 60050-191		Internationales Elektrotechnisches Wörterbuch; Kapitel 191: Zuverlässigkeit und Dienstgüte	International electrotechnical vocabulary; chapter 191: dependability and quality of service
IEC 60050-601		Internationales Elektrotechnisches Wörterbuch; Erzeugung, Übertragung und Verteilung elektrischer Energie – Allgemeines	International Electrotechnical Vocabulary. Part 601: Chapter 601 : Generation, transmission and distribution of electricity – General
IEC 60068-2-30		Umgebungseinflüsse – Teil 2-30: Prüfverfahren – Prüfung Db: Feuchte Wärme, zyklisch (12 + 12 Stunden)	Environmental testing – Part 2-30: Tests – Test Db: Damp heat, cyclic (12 h + 12 h cycle)
IEC 60071-1	VDE 0111-1	Isolationskoordination – Teil 1: Begriffe, Grundsätze und Anforderungen	Insulation co-ordination – Part 1: Definitions, principles and rules
IEC 60076-1	VDE 0532-76-1	Leistungstransformatoren – Teil 1: Allgemeines	Power transformers – Part 1: General
IEC 60076-11	VDE 0532-76-11	Leistungstransformatoren – Teil 11: Trockentransformatoren	Power transformers – Part 11: Dry-type transformers
IEC 60076-12	VDE 0532-76-12	Leistungstransformatoren – Teil 12: Leitfaden für die Belastung von Trocken-Leistungstransformatoren	Power transformers – Part 12: Loading guide for dry-type power transformers
IEC 60076-2	VDE 0532-76-2	Leistungstransformatoren – Teil 2: Übertemperaturen für flüssigkeitsgefüllte Transformatoren	Power transformers – Part 2: Temperature rise for liquid-immersed transformers
IEC 60076-5	VDE 0532-76-5	Leistungstransformatoren – Teil 5: Kurzschlussfestigkeit	Power transformers – Part 5: Ability to withstand short circuit
IEC 60076-6	VDE 0532-76-6	Leistungstransformatoren – Teil 6: Drosselspulen	Power transformers – Part 6: Reactors
IEC 60076-7	VDE 0532-76-7	Leistungstransformatoren – Teil 7: Belastungsrichtlinie für ölgefüllte Leistungstransformatoren	Power transformers – Part 7: Loading guide for oil-immersed power transformers
IEC 60204-1	VDE 0113-1	Sicherheit von Maschinen – Elektrische Ausrüstung von Maschinen – Teil 1: Allgemeine Anforderungen	Safety of machinery – Electrical equipment of machines – Part 1: General requirements
IEC 60204-11	VDE 0113-11	Sicherheit von Maschinen – Elektrische Ausrüstung von Maschinen – Teil 11: Anforderungen an Hochspannungsausrüstung für Spannungen über 1000 V Wechselspannung oder 1500 V Gleichspannung aber nicht über 36 kV	Safety of machinery – Electrical equipment of machines – Part 11: Requirements for HV equipment for voltages above 1000 V a.c. or 1500 V d.c. and not exceeding 36 kV
IEC 60255-151	VDE 0435-3151	Messrelais und Schutzeinrichtungen – Teil 151: Funktionsanforderungen für Über-/Unterstromschutz	Measuring relays and protection equipment – Part 151: Functional requirements for over/under current protection
IEC 60269-1	VDE 0636-1	Niederspannungssicherungen – Teil 1: Allgemeine Anforderungen	Low-voltage fuses – Part 1: General requirements
IEC 60269-2	VDE 0636-2	Niederspannungssicherungen – Teil 2: Zusätzliche Anforderungen an Sicherungen zum Gebrauch durch Elektrofachkräfte bzw. elektrotechnisch unterwiesene Personen (Sicherungen überwiegend für den industriellen Gebrauch) – Beispiele für genormte Sicherungssysteme A bis K	Low-voltage fuses – Part 2: Supplementary requirements for fuses for use by authorized persons (fuses mainly for industrial application) – Examples of standardized systems of fuses A to K
IEC 60269-6	VDE 0636-6	Niederspannungssicherungen – Teil 6: Zusätzliche Anforderungen an Sicherungseinsätze für den Schutz von solaren photovoltaischen Energieerzeugungssystemen	Low-voltage fuses – Part 6: Supplementary requirements for fuse-links for the protection of solar photovoltaic energy systems
IEC 60282-1	VDE 0670-4	Hochspannungssicherungen – Teil 1: Strombegrenzende Sicherungen	High-voltage fuses – Part 1: Current-limiting fuses

International	Germany	German title	English title
IEC 60296	VDE 0370-1	Flüssigkeiten für elektrotechnische Anwendungen – Neue Isolieröle auf Mineralölbasis für Transformatoren und Schaltgeräte	Fluids for electrotechnical applications – Unused mineral insulating oils for transformers and switchgear
IEC 60364-1	VDE 0100-100	Errichten von Niederspannungsanlagen – Teil 1: Allgemeine Grundsätze, Bestimmungen allgemeiner Merkmale, Begriffe	Low-voltage electrical installations – Part 1: Fundamental principles, assessment of general characteristics, definitions
IEC 60364-4-41	VDE 0100-410	Elektrische Anlagen von Gebäuden – Teil 4-41: Schutzmassnahmen – Schutz gegen elektrischen Schlag	Low-voltage electrical installations – Part 4-41: Protection for safety – Protection against electric shock
IEC 60364-4-43	VDE 0100-430	Errichten von Niederspannungsanlagen – Teil 4-43: Schutzmaßnahmen – Schutz bei Überstrom	Low-voltage electrical installations – Part 4-43: Protection for safety – Protection against overcurrent
IEC 60364-5-52	VDE 0100-520	Errichten von Niederspannungsanlagen – Teil 5-52: Auswahl und Errichtung elektrischer Betriebsmittel – Kabel- und Leitungsanlagen	Low-voltage electrical installations – Part 5-52: Selection and erection of electrical equipment – Wiring systems
IEC 60364-5-53	VDE 0100-530	Elektrische Anlagen von Gebäuden – Teil 5-53: Auswahl und Errichtung elektrischer Betriebsmittel; Trennen, Schalten und Steuern	Electrical installations of buildings – Part 5-53: Selection and erection of electrical equipment; Isolation, switching and control
IEC 60364-5-54	VDE 0100-540	Errichten von Niederspannungsanlagen – Teil 5-54: Auswahl und Errichtung elektrischer Betriebsmittel – Erdungsanlagen, Schutzleiter und Schutzpotentialausgleichsleiter	Low-voltage electrical installations – Part 5-54: Selection and erection of electrical equipment – Earthing arrangements and protection conductors
IEC 60364-5-56	VDE 0100-560	Errichten von Niederspannungseinrichtungen – Teil 5-56: Auswahl und Errichtung elektrischer Betriebsmittel – Einrichtungen für Sicherheitszwecke	Low-voltage electrical installations – Part 5-56: Selection and erection of electrical equipment – Safety services
IEC 60364-6	VDE 0100-600	Errichten von Niederspannungsanlagen – Teil 6: Prüfungen	Low-voltage electrical installations – Part 6: Verification
IEC 60364-7-710	VDE 0100-710	Elektrische Anlagen von Gebäuden – Teil 7-710: Anforderungen für Betriebsstätten, Räume und Anlagen besonderer Art; Medizinisch genutzte Bereiche	Electrical installations of buildings – Part 7-710: Requirements for special installations or locations; Medical locations
IEC 60364-7-718	VDE 0100-718	Errichten von Niederspannungsanlagen – Teil 7-718: Anforderungen für Betriebsstätten, Räume und Anlagen besonderer Art – Öffentliche Einrichtungen und Arbeitsstätten	Low-voltage electrical installations – Part 7-718: Requirements for special installations or locations – Communal facilities and workplaces
IEC 60364-7-729	VDE 0100-729	Errichten von Niederspannungsanlagen – Anforderungen für Betriebsstätten, Räume und Anlagen besonderer Art – Teil 7-729: Bedienungsgänge und Wartungsgänge	Low-voltage electrical installations – Part 7-729: Requirements for special installations or locations – Operating or maintenance gangways
IEC 60529	VDE 0470-1	Schutzarten durch Gehäuse (IP-Code)	Degrees of protection provided by enclosures (IP Code)
IEC 60570	VDE 0711-300	Elektrische Stromschienensysteme für Leuchten	Electrical supply track systems for luminaires
IEC 60598-1	VDE 0711-1	Leuchten – Teil 1: Allgemeine Anforderungen und Prüfungen	Luminaires – Part 1: General requirements and tests
IEC 60598-2-22	VDE 0711-2-22	Leuchten – Teil 2-22: Besondere Anforderungen – Leuchten für Notbeleuchtung	Luminaires – Part 2-22: Particular requirements – Luminaires for emergency lighting
IEC 60617-DB		Graphische Symbole für Schaltpläne (Schaltzeichen) / Online-Datenbank – Die Datenbank ersetzt IEC 60617-2 bis -13	Graphical symbols for diagrams / Online-Database – The database replaces part 2 to 13 of IEC 60617
IEC 60664-1	VDE 0110-1	Isolationskoordination für elektrische Betriebsmittel in Niederspannungsanlagen – Teil 1: Grundsätze, Anforderungen und Prüfungen	Insulation coordination for equipment within low-voltage systems – Part 1: Principles, requirements and tests
IEC 60831-1	VDE 0560-46	Selbstheilende Leistungs-Parallelkondensatoren für Wechselstromanlagen mit einer Nennspannung bis 1 kV – Teil 1: Allgemeines; Leistungsanforderungen, Prüfung und Bemessung; Sicherheitsanforderungen; Anleitung für Errichtung und Betrieb	Shunt power capacitors of the self-healing type for a.c. systems having a rated voltage up to and including 1 kV – Part 1: General; Performance, testing and rating; Safety requirements; Guide for installation and operation
IEC 60870-5-101		Fernwerkeinrichtungen und -systeme – Teil 5: Übertragungsprotokolle; Hauptabschnitt 1: Telegrammformate Fernwerkeinrichtungen und -systeme – Teil 5-101: Übertragungsprotokolle; Anwendungsbezogene Norm für grundlegende Fernwirkaufgaben	Telecontrol equipment and systems – Part 5-101: Transmission protocols; Companion standard for basic telecontrol tasks

International	Germany	German title	English title
IEC 60870-5-104		Fernwerkeinrichtungen und -systeme – Teil 5-104: Übertragungsprotokolle – Zugriff für IEC 60870-5-101 auf Netze mit genormten Transportprofilen	Telecontrol equipment and systems – Part 5-104: Transmission protocols – Network access for IEC 60870-5-101 using standard transport profiles
IEC 60896-21		Ortsfeste Blei-Akkumulatoren – Teil 21: Verschlussene Bauarten – Prüfverfahren	Stationary lead-acid batteries – Part 21: Valve regulated types – Methods of test
IEC 60898-1	VDE 0641-11	Elektrisches Installationsmaterial – Leitungsschalter für Hausinstallationen und ähnliche Zwecke – Teil 1: Leitungsschutzschalter für Wechselstrom (AC)	Electrical accessories – Circuit-breakers for overcurrent protection for household and similar installations – Part 1: Circuit-breakers for a.c. operation
IEC 60898-2	VDE 0641-12	Leitungsschutzschalter für Hausinstallationen und ähnliche Zwecke – Teil 2: Leitungsschutzschalter für Wechsel- und Gleichstrom	Circuit-breakers for overcurrent protection for household an similar installations – Part 2: Circuit-breakers for a.c. and d.c. operation
IEC 60947-1	VDE 0660-100	Niederspannungsschaltgeräte – Teil 1: Allgemeine Festlegungen	Low-voltage switchgear and controlgear – Part 1: General rules
IEC 60947-2	VDE 0660-101	Niederspannungsschaltgeräte – Teil 2: Leistungsschalter	Low-voltage switchgear and controlgear – Part 2: Circuit-breakers
IEC 60947-3	VDE 0660-107	Niederspannungsschaltgeräte – Teil 3: Lastschalter, Trennschalter, Lasttrennschalter und Schalter-Sicherungs-Einheiten	Low-voltage switchgear and controlgear – Part 3: Switches, disconnectors, switch-disconnectors and fuse-combination units
IEC 60947-4-1	VDE 0660-102	Niederspannungsschaltgeräte – Teil 4-1: Schütze und Motorstarter – Elektromechanische Schütze und Motorstarter	Low-voltage switchgear and controlgear – Part 4-1: Contactors and motor-starters – Electromechanical contactors and motor-starters
IEC 60947-4-2	VDE 0660-117	Niederspannungsschaltgeräte – Teil 4-2: Schütze und Motorstarter – Halbleiter-Motor-Steuergeräte und -Starter für Wechselspannungen	Low-voltage switchgear and controlgear – Part 4-2: Contactors and motor-starters – AC semiconductor motor controllers and starters
IEC 60947-8	VDE 0660-302	Niederspannungsschaltgeräte – Teil 8: Auslösegeräte für den eingebauten thermischen Schutz (PTC) von rotierenden elektrischen Maschinen	Low-voltage switchgear and controlgear – Part 8: Control units for built-in thermal protection (PTC) for rotating electrical machines
IEC 61000-2-12	VDE 0839-2-12	Elektromagnetische Verträglichkeit (EMV) – Teil 2-12: Umgebungsbedingungen; Verträglichkeitspegel für niederfrequente leitungsgeführte Störgrößen und Signalübertragung in öffentlichen Mittelspannungsnetzen; EMV-Grundnorm	Electromagnetic compatibility (EMC) – Part 2-12: Environment; Compatibility levels for low-frequency conducted disturbances and signalling in public medium-voltage power supply systems; Basic EMC Publication
IEC 61000-2-2	VDE 0839-2-2	Elektromagnetische Verträglichkeit (EMV) – Teil 2-2: Umgebungsbedingungen; Verträglichkeitspegel für niederfrequente leitungsgeführte Störgrößen und Signalübertragung in öffentlichen Niederspannungsnetzen	Electromagnetic compatibility (EMC) – Part 2-2: Environment; Compatibility levels for low-frequency conducted disturbances and signalling in public low-voltage power supply systems
IEC 61000-2-4	VDE 0839-2-4	Elektromagnetische Verträglichkeit (EMV) – Teil 2-4: Umgebungsbedingungen; Verträglichkeitspegel für niederfrequente leitungsgeführte Störgrößen in Industrieanlagen	Electromagnetic compatibility (EMC) – Part 2-4: Environment; Compatibility levels in industrial plants for low-frequency conducted disturbances
IEC 61000-3-11	VDE 0838-11	Elektromagnetische Verträglichkeit (EMV) – Teil 3-11: Grenzwerte; Begrenzung von Spannungsänderungen, Spannungsschwankungen und Flicker in öffentlichen Niederspannungs-Versorgungsnetzen; Geräte und Einrichtungen mit einem Bemessungsstrom $\leq 75$ A, die einer Sonderanschlussbedingung unterliegen	Electromagnetic compatibility (EMC) – Part 3-11: Limits – Limitation of voltage changes, voltage fluctuations and flicker in public low-voltage supply systems – Equipment with rated current $\leq 75$ A and subject to conditional connection
IEC 61000-3-12	VDE 0838-12	Elektromagnetische Verträglichkeit (EMV) – Teil 3-12: Grenzwerte für Oberschwingungsströme, verursacht von Geräten und Einrichtungen mit einem Eingangsstrom $> 16$ A und $\leq 75$ A je Leiter, die zum Anschluss an öffentliche Niederspannungsnetze vorgesehen sind	Electromagnetic compatibility (EMC) – Part 3-12: Limits – Limits for harmonic currents produced by equipment connected to public low-voltage systems with input current $> 16$ A und $\leq 75$ A per phase
IEC 61000-3-2	VDE 0838-2	Elektromagnetische Verträglichkeit (EMV) – Teil 3-2: Grenzwerte – Grenzwerte für Oberschwingungsströme (Geräte-Eingangsstrom $\leq 16$ A je Leiter)	Electromagnetic compatibility (EMC) – Part 3-2: Limits – Limits for harmonic current emissions (equipment input current $\leq 16$ A per phase)

International	Germany	German title	English title
IEC 61000-3-3	VDE 0838-3	Elektromagnetische Verträglichkeit (EMV) – Teil 3-3: Grenzwerte – Begrenzung von Spannungsänderungen, Spannungsschwankungen und Flicker in öffentlichen Niederspannungs-Versorgungsnetzen für Geräte mit einem Bemessungsstrom = 16 A je Leiter, die keiner Sonderanschlussbedingung unterliegen	Electromagnetic compatibility (EMC) – Part 3: Limits – Section 8: Signalling on low-voltage electrical installations – Emission levels, frequency bands and electromagnetic disturbance levels
IEC 61000-4-15	VDE 0847-4-15	Elektromagnetische Verträglichkeit (EMV) – Teil 4-15: Prüf- und Messverfahren – Flickermeter – Funktionsbeschreibung und Auslegungsspezifikation	Electromagnetic compatibility (EMC) – Part 4-15: Testing and measurement techniques – Flickermeter – Functional and design specifications
IEC 61000-4-30	VDE 0847-4-30	Elektromagnetische Verträglichkeit (EMV) – Teil 4-30: Prüf- und Messverfahren – Verfahren zur Messung der Spannungsqualität	Electromagnetic compatibility (EMC) – Testing and measurement techniques – Power quality measurement methods
IEC 61000-4-7	VDE 0847-4-7	Elektromagnetische Verträglichkeit (EMV) – Teil 4-7: Prüf- und Messverfahren; Allgemeiner Leitfadens für Verfahren und Geräte zur Messung von Oberschwingungen und Zwischenharmonischen in Stromversorgungsnetzen und angeschlossenen Geräten	Electromagnetic compatibility (EMC) – Part 4-7: Testing and measurement techniques; General guide on harmonics and interharmonics measurements and instrumentation, for power supply systems and equipment connected thereto
IEC 61009-1	VDE 0664-20	Fehlerstrom-/Differenzstrom-Schutzschalter mit eingebautem Überstromschutz (RCBOs) für Hausinstallationen und für ähnliche Anwendungen – Teil 1: Allgemeine Anforderungen	Residual current operated circuit-breakers with integral overcurrent protection for household and similar uses (RCBOs) – Part 1: General rules
IEC 61131-3		Speicherprogrammierbare Steuerungen – Teil 3: Programmiersprachen	Programmable controllers – Part 3: Programming languages
IEC 61140	VDE 0140-1	Schutz gegen elektrischen Schlag – Gemeinsame Anforderungen für Anlagen und Betriebsmittel	Protection against electric shock – Common aspects for installation and equipment
IEC 61347-1	VDE 0712-30	Geräte für Lampen: Allgemeine und Sicherheitsanforderungen	Lamp controlgear – Part 1: General and safety requirements
IEC 61347-2-...	VDE 0712-...	Geräte für Lampen – Teil 2- ... : Besondere Anforderungen an ...	Lamp controlgear – Part 2- ... : Particular requirements for ...
IEC 61400-1		Windenergieanlagen – Teil 1: Auslegungsanforderungen	Wind turbines – Part 1: Design requirements
IEC 61439-1	VDE 0660-600-1	Niederspannungs-Schaltgerätekombinationen – Teil 1: Allgemeine Festlegungen	Low-voltage switchgear and controlgear assemblies – Part 1: General rules
IEC 61439-2	VDE 0660-600-2	Niederspannungs-Schaltgerätekombinationen – Teil 2: Energie-Schaltgerätekombinationen	Low-voltage switchgear and controlgear assemblies – Part 2: Power switchgear and controlgear assemblies
IEC 61439-3	VDE 0660-600-3	Niederspannungs-Schaltgerätekombinationen – Teil 3: Installationsverteiler für die Bedienung durch Laien (DBO)	Low-voltage switchgear and controlgear assemblies – Part 3: Distribution boards intended to be operated by ordinary persons (DBO)
IEC 61439-6	VDE 0660-600-6	Niederspannungs-Schaltgerätekombinationen – Teil 6: Schienenvertersysteme (busways)	Low-voltage switchgear and controlgear assemblies – Part 6: Busbar trunking systems (busways)
IEC 61547	VDE 0875-15-2	Einrichtungen für allgemeine Beleuchtungszwecke – EMV-Störfestigkeitsanforderungen	Equipment for general lighting purposes – EMC immunity requirements
IEC 61800-3	VDE 0160-103	Drehzahlveränderbare elektrische Antriebe – Teil 3: Anforderungen einschließlich spezieller Prüfverfahren	Adjustable speed electrical power drive systems – Part 3: EMC requirements and specific test methods
IEC 61869-1	VDE 0414-9-1	Messwandler – Teil 1: Allgemeine Anforderungen	Instrument transformers – Part 1: General requirements
IEC 61869-2	VDE 0414-9-2	Messwandler – Teil 2: Zusätzliche Anforderungen für Stromwandler	Instrument transformers – Part 2: Additional requirements for current transformers
IEC 61869-3	VDE 0414-9-3	Messwandler – Teil 3: Zusätzliche Anforderungen für induktive Spannungswandler	Instrument transformers – Part 3: Additional requirements for inductive voltage transformers
IEC 61869-4	VDE 0414-9-4	Messwandler – Teil 4: Zusätzliche Anforderungen für kombinierte Wandler	Instrument transformers – Part 4: Additional requirements for combined transformers
IEC 61936-1	VDE 0101-1	Starkstromanlagen mit Nennwechselspannungen über 1 kV – Teil 1: Allgemeine Bestimmungen	Power installations exceeding 1 kV a.c. – Part 1: Common rules
IEC 62034	VDI 0711-400	Automatische Prüfsysteme für batteriebetriebene Sicherheitsbeleuchtung für Rettungswege	Automatic test systems for battery powered emergency escape lighting

International	Germany	German title	English title
IEC 62040-1	VDE 0558-510	Unterbrechungsfreie Stromversorgungssysteme (USV) – Teil 1: Allgemeine Anforderungen und Sicherheitsanforderungen	Uninterruptible power systems (UPS) – Part 1: General and safety requirements for UPS
IEC 62040-2	VDE 0558-520	Unterbrechungsfreie Stromversorgungssysteme (USV) – Teil 2: Anforderungen an die elektromagnetische Verträglichkeit (EMV)	Uninterruptible power systems (UPS) – Part 2: Electromagnetic compatibility (EMC) requirements
IEC 62040-3	VDE 0558-530	Unterbrechungsfreie Stromversorgungssysteme (USV) – Teil 3: Methoden zum Festlegen der Leistungs- und Prüfungsanforderungen	Uninterruptible power systems (UPS) – Part 3: Method of specifying the performance and test requirements
IEC 62061	VDE 0113-50	Sicherheit von Maschinen – Funktionale Sicherheit sicherheitsbezogener elektrischer, elektronischer und programmierbarer elektronischer Steuerungssysteme	Safety of machinery – Functional safety of safety-related electrical, electronic and programmable electronic control systems
IEC 62271-100	VDE 0671-100	Hochspannungs-Schaltgeräte und -Schaltanlagen – Teil 100: Wechselstrom-Leistungsschalter	High-voltage switchgear and controlgear – Part 100: Alternating-current circuit-breakers
IEC 62271-102	VDE 0671-102	Hochspannungs-Schaltgeräte und -Schaltanlagen – Teil 102: Wechselstrom-Trennschalter und -Erdungsschalter	High-voltage switchgear and controlgear – Part 102: Alternating current disconnectors and earthing switches
IEC 62271-103	VDE 0671-103	Hochspannungs-Schaltgeräte und -Schaltanlagen – Teil 103: Lastschalter für Bemessungsspannungen über 1 kV bis einschliesslich 52 kV	High-voltage switchgear and controlgear – Part 103: Switches for rated voltages above 1 kV up to and including 52 kV
IEC 62271-105	VDE 0671-105	Hochspannungs-Schaltgeräte und -Schaltanlagen – Teil 105: Wechselstrom-Lastschalter-Sicherungs-Kombinationen für Bemessungsspannungen über 1 kV bis einschliesslich 52 kV	High-voltage switchgear and controlgear – Part 105: Alternating current switch-fuse combinations for rated voltages above 1 kV up to and including 52 kV
IEC 62271-106	VDE 0671-106	Hochspannungs-Schaltgeräte und -Schaltanlagen – Teil 106: Wechselstrom-Schütze, Kombinationsstarter und Motorstarter mit Schützen	High-voltage switchgear and controlgear – Part 106: Alternating current contactors, contactor-based controllers and motor-starters
IEC 62271-200	VDE 0671-200	Hochspannungs-Schaltgeräte und -Schaltanlagen – Teil 200: Metallgekapselte Wechselstrom-Schaltanlagen für Bemessungsspannungen über 1 kV bis einschliesslich 52 kV	High-voltage switchgear and controlgear – Part 200: AC metal-enclosed switchgear and controlgear for rated voltages above 1 kV and up to and including 52 kV
IEC 62271-201	VDE 0671-201	Hochspannungs-Schaltgeräte und -Schaltanlagen – Teil 201: Isolierstoffgekapselte Wechselstrom-Schaltanlagen für Bemessungsspannungen über 1 kV bis einschliesslich 52 kV	High-voltage switchgear and controlgear – Part 201: AC insulation-enclosed switchgear and controlgear for rated voltages above 1 kV and up to and including 52 kV
IEC 62271-202	VDE 0671-202	Hochspannungs-Schaltgeräte und -Schaltanlagen – Teil 202: Fabrikfertige Stationen für Hochspannung/Niederspannung	High-voltage switchgear and controlgear – Part 202: High voltage/low voltage prefabricated substation
IEC 62305-2	VDE 0185-305-2	Blitzschutz – Teil 2: Risiko-Management	Protection against lightning – Part 2: Risk management
IEC 62305-3	VDE 0185-305-3	Blitzschutz – Teil 3: Schutz von baulichen Anlagen und Personen	Protection against lightning – Part 3: Physical damage to structures and life hazard
IEC 62305-4	VDE 0185-305-4	Blitzschutz – Teil 4: Elektrische und elektronische Systeme in baulichen Anlagen	Protection against lightning – Part 4: Electrical and electronic systems within structures
IEC 62471	VDE 0837-471	Photobiologische Sicherheit von Lampen und Lampensystemen	Photobiological safety of lamps and lamp systems
IEC 62493	VDE 0848-493	Beurteilung von Beleuchtungseinrichtungen bezüglich der Exposition von Personen gegenüber elektromagnetischen Feldern	Assessment of lighting equipment related to human exposure to electromagnetic fields
IEC 62606	Entwurf VDE 0665-10	Allgemeine Anforderungen an Fehlerlichtbogen-Schutzeinrichtungen (AFDD)	General requirements for arc fault detection devices (AFDD)
IEC/PAS 62717		LED-Module für die Allgemeinbeleuchtung – Anforderungen an die Arbeitsweise	LED modules for general lighting – Performance requirements

International	Germany	German title	English title
IEC/TR 61641	VDE 0660-500 Beiblatt 2	Niederspannungs-Schaltgerätekombinationen in geschlossener Bauform – Leitfaden für die Prüfung unter Störlichtbogenbedingungen durch einen inneren Fehler	Enclosed low-voltage switchgear and controlgear assemblies – Guide for testing under conditions of arcing due to internal fault
IEC/TR 62655	VDE 0670-402	Wechselstromschaltgeräte für Spannungen über 1 kV – Auswahl von strombegrenzenden Sicherungseinsätzen für Transformatorstromkreise	Tutorial and application guide for high-voltage fuses
IEC/TS 60479-1	VDE V 0140-479-1	Wirkungen des elektrischen Stromes auf Menschen und Nutztiere – Teil 1: Allgemeine Aspekte	Effects of current on human beings and livestock – Part 1: General aspects
IEC/TS 62351-1		Energiemanagementsysteme und zugehöriger Datenaustausch – IT Sicherheit für Daten und Kommunikation – Teil 1: Einführung in die Sicherheitsthematik	Power systems management and associated information exchange – Data and communications security – Part 1: Communication network and system security – Introduction to security issues
IEEE 446		Empfohlene Praxis für Not- und Reservestromnetze für industrielle und gewerbliche Zwecke	Recommended Practice for Emergency and Standby Power Systems for Industrial and Commercial Applications (Orange book)
ISO 12100		Sicherheit von Maschinen – Allgemeine Gestaltungsleitsätze – Risikobeurteilung und Risikominderung	Safety of machinery – General principles for design – Risk assessment and risk reduction
ISO 13849-1		Sicherheit von Maschinen – Sicherheitsbezogene Teile von Steuerungen – Teil 1: Allgemeine Gestaltungsleitsätze	Safety of machinery – Safety-related parts of control systems – Part 1: General principles for design
ISO 14001		Umweltmanagementsysteme. Anforderungen mit Anleitung zur Anwendung	Environmental Management Systems – Specification with Guidance for Use
ISO 23570-2		Industrielle Automatisierungssysteme und deren Anwendung: Teil 2: Hybrider Kommunikationsbus	Industrial automation systems and integration – Distributed installation in industrial applications – Part 2: Hybrid communication bus
ISO 23570-3		Industrielle Automatisierungssysteme und deren Anwendung: Teil 2: Bussystem für Stromverteilung	Industrial automation systems and integration – Distributed installation in industrial applications – Part 3: Power distribution bus
ISO 23601		Sicherheitskennzeichnung – Fluchtwegpläne	Safety identification – Escape and evacuation plan signs
ISO 3864		Normenreihe graphische Symbole – Sicherheitsfarben und Sicherheitszeichen	Group of standards for graphical symbols – Safety colours and safety signs
ISO 50001		Energiemanagementsysteme – Anforderungen mit Anleitung zur Anwendung	Energy management systems – Requirements with guidance for use
ISO 9001		Qualitätsmanagementsysteme – Anforderungen	Quality management systems – Requirements
	VDE 0710-13	Leuchten mit Betriebsspannungen unter 1000 V; Ballwurfsichere Leuchten VDE-Bestimmung	Luminaires with operating voltages below 1000 V; luminaires safety to ball throwing VDE Specification
	DIN 4102-2	Brandverhalten von Baustoffen und Bauteilen; Bauteile, Begriffe, Anforderungen und Prüfungen	Fire Behaviour of Building Materials and Building Components; Building Components; Definitions, Requirements and Tests
	DIN 4102-9	Brandverhalten von Baustoffen und Bauteilen; Kabelabschottungen; Begriffe, Anforderungen und Prüfungen	Fire behaviour of building materials and elements; seals for cable penetrations; concepts, requirements and testing
	EltBauVO	Verordnung über den Bau von Betriebsräumen für elektrische Anlagen	Regulation for the construction of operation rooms for electrical equipment
	HOAI 2013	Deutsche Honorarordnung für Architekten und Ingenieure	German fee structure imposed on architects and engineers
	DIN 276	Normenreihe – Kosten im Bauwesen	Series of standards – Building costs
	DIN 6280-12	Stromerzeugungsaggregate – Unterbrechungsfreie Stromversorgung – Teil 12: Dynamische USV-Anlagen mit und ohne Hubkolben-Verbrennungsmotor	Generating sets – Uninterruptible power supply – Part 12: Dynamic UPS systems with and without reciprocating internal combustion engines
	DIN VDE V 0126-1-1	Selbsttätige Schaltstelle zwischen einer netzparallelen Eigenerzeugungsanlage und dem öffentlichen Niederspannungsnetz	Automatic disconnection device between a generator and the public low-voltage grid

International	Germany	German title	English title
	VDEW-Richtlinie 2004	Notstromaggregate – Richtlinie für Planung, Errichtung, Betrieb von Anlagen mit Notstromaggregaten	
	DIN 43880	Installationseinbaugeräte; Hüllmasse und zugehörige Einbaumasse	Built-in equipment for electrical installations; overall dimensions and related mounting dimensions
	DIN 40041	Zuverlässigkeit; Begriffe	Dependability; concepts
	BSI-Standard 100-3	Risikoanalyse auf Basis von IT-Grundschutz	Risk Analysis on the Basis of IT-Grundschutz
	VDE 0670-402	Wechselstromschaltgeräte für Spannungen über 1 kV; Auswahl von strombegrenzenden Sicherungseinsätzen für Transformatorstromkreise	A.C. switchgear and controlgear for voltages above 1 kV; application guide for the selection of fuse-links for transformer circuits
	Entwurf VDE 0662	Ortsfeste Schutzeinrichtungen in Steckdosenausführung zur Schutzpegelerhöhung	Fixed socket-outlets with residual current devices intended for an increase in the protection level
	EMVG	Gesetz über die elektromagnetische Verträglichkeit von Betriebsmitteln (2008; basierend auf der EMV-Richtlinie 2004/108/EG)	Law on the Electromagnetic Compatibility of Equipment (2008; based on EC-directive 2004/108/EC)
	VDI 4602-1	Energiemanagement – Begriffe, Definitionen	Energy management – Terms, definitions
	VDI 4602-2	Energiemanagement – Beispiele	Energy management – Examples
	EnEV	Energieeinsparverordnung	Energy saving directive
	VDI 3807-4	Energie- und Wasserverbrauchskennwerte für Gebäude – Teilkennwerte elektrische Energie	Characteristic values of energy and water consumption of buildings – Characteristic values for electrical energy
	DIN 5035-7	Beleuchtung mit künstlichem Licht – Teil 7: Beleuchtung von Räumen mit Bildschirmarbeitsplätzen	Artificial Lighting – Part 7: Lighting of interiors with visual displays work stations
	DIN 5035-8	Beleuchtung mit künstlichem Licht – Teil 8: Arbeitsplatzleuchten – Anforderungen, Empfehlungen und Prüfung	Artificial lighting – Part 8: Workplace luminaries – Requirements, recommendations and proofing
	DIN V 18599-1	Energetische Bewertung von Gebäuden – Berechnung des Nutz-, End- und Primärenergiebedarfs für Heizung, Kühlung, Lüftung, Trinkwarmwasser und Beleuchtung – Teil 1: Allgemeine Bilanzierungsverfahren, Begriffe, Zonierung und Bewertung der Energieträger	Energy efficiency of buildings – Calculation of the net, final and primary energy demand for heating, cooling, ventilation, domestic hot water and lighting – Part 1: General balancing procedures, terms and definitions, zoning and evaluation of energy sources
	DIN V 18599-4	Energetische Bewertung von Gebäuden – Berechnung des Nutz-, End- und Primärenergiebedarfs für Heizung, Kühlung, Lüftung, Trinkwarmwasser und Beleuchtung – Teil 4: Nutz- und Endenergiebedarf für Beleuchtung	Energy efficiency of buildings – Calculation of the net, final and primary energy demand for heating, cooling, ventilation, domestic hot water and lighting – Part 4: Net and final energy demand for lighting
	DIN V 18599-10	Energetische Bewertung von Gebäuden – Berechnung des Nutz-, End- und Primärenergiebedarfs für Heizung, Kühlung, Lüftung, Trinkwarmwasser und Beleuchtung – Teil 10: Nutzungsrandbedingungen, Klimadaten	Energy efficiency of buildings – Calculation of the net, final and primary energy demand for heating, cooling, ventilation, domestic hot water and lighting – Part 10: Boundary conditions of use, climatic data
	DIN Spec 67600	Biologisch wirksame Beleuchtung – Planungsempfehlungen	Biologically effective illumination – Design guidelines
	ASR A3.4	Technische Regeln für Arbeitsstätten in Bezug auf Beleuchtung	Technical workplace regulation on lighting systems

International	Germany	German title	English title
	BGI 650	Berufsgenossenschaftliche Information für Bildschirm- und Büroarbeitsplätze	Berufsgenossenschaftliche information about monitor and office workplaces
	VDI 6011-1	Richtlinie zur Optimierung von Tageslichtnutzung und künstlicher Beleuchtung	Optimisation of daylighting and artificial lighting – Fundamentals
	DIN V 5031-100	Strahlungsphysik im optischen Bereich und Lichttechnik – Teil 100: Über das Auge vermittelte, nichtvisuelle Wirkung des Lichts auf den Menschen – Größen, Formelzeichen und Wirkungsspektren	Optical radiation physics and illuminating engineering – Part 100: Non-visual effects of ocular light on human beings – Quantities, symbols and action spectra
	BGR/GUV-R	Berufsgenossenschaftliche Regeln für Sicherheit und Gesundheit bei der Arbeit	
	MBO	Musterbauordnung	Standard building code
	LBO	Landesbauordnung	Building regulation of the state ("Land")
	ArbstättV	Arbeitsstättenverordnung	Ordinance on health and safety at work
	MPrüfVo	Musterprüfverordnung	
	BetrSichV	Betriebssicherheitsverordnung	Ordinance on Industrial Safety and Health
	BGV	Berufsgenossenschaftliche Vorschriften	Employers' Liability Association regulations BGV
	MLAR	Muster-Leitungsanlagen-Richtlinie	Regulation on fire security of conduit installations
ASchG		ArbeitnehmerInnenschutzgesetz	Occupational Safety and Health at Work for Employees
	ASR	Technische Regeln für Arbeitsstätten	Technical workplace regulation
	VDE V 0108-100	Sicherheitsbeleuchtungsanlagen	Emergency escape lighting systems
	DIN 4844-1	Graphische Symbole – Sicherheitsfarben und Sicherheitszeichen – Teil 1: Erkennungsweiten und farb- und photometrische Anforderungen	Graphical symbols – Safety colours and safety signs – Part 1: Observation distances and colorimetric and photometric requirements
	DIN 4844-2	Graphische Symbole – Sicherheitsfarben und Sicherheitszeichen – Teil 2: Registrierte Sicherheitszeichen	Graphical symbols – Safety colours and safety signs – Part 2: Registered safety signs
ÖVE/ÖNORM E8002		Normenreihe zu Starkstromanlagen und Sicherheitsstromversorgung in baulichen Anlagen für Menschenansammlungen	Series of standards about power installation and safety power supply in communal facilities
	DIN 4102-12	Brandverhalten von Baustoffen und Bauteilen – Teil 12: Funktionserhalt von elektrischen Kabelanlagen; Anforderungen und Prüfungen	Fire behaviour of building materials and building components – Part 12: Circuit integrity maintenance of electric cable systems; requirements and testing
	VDE-AR-N 4105	Erzeugungsanlagen am Niederspannungsnetz – Technische Mindestanforderungen für Anschluss und Parallelbetrieb von Erzeugungsanlagen am Niederspannungsnetz	Generators connected to the low-voltage distribution network – Technical requirements for the connection to and parallel operation with low-voltage distribution networks
	GL 2010		Guideline for the Certification of Wind Turbines Edition 2010
	GL 2012		Guideline for the Certification of Offshore Wind Turbines Edition 2012



### 17.3 List of Abbreviations

**A**

A/D	Analog/digital
AC	Alternating current
ACB	Air circuit-breaker
AEC	Availability Environment Classification
AEP	Average electricity price
AF	Audio frequency
AFDD	Arc-fault detection device
AFE	Active front end
AIS	Air-insulated switchgear
ANSI	American National Standards Institute
ASR	Technical workplace regulation
AVC	Availability class

**B**

BA/TBM	Building automation/Technical building management
BCL	Busbar coupler longitudinal
BCT	Busbar coupler transversal
BDEW	Bundesverband der Energie- und Wasserwirtschaft e.V. (Registered Federal Association of the Energy and Water Industry, Germany)
BGI	Information of the German Employer's Liability Insurance Association
BGR/GUV	Rule of the German Employer's Liability Insurance Association / Statutory Accident Insurance
BGV	Provision of the German Employer's Liability Insurance Association
BSI	German Federal Office for Information Security
BT	Battery test, continuous
BTS	Busbar trunking system

**C**

CAES	Compressed air energy storage
CB	Conventional ballast
CBEMA	Computer and Business Equipment Manufacturing Association
CBR	Circuit-breaker incorporating residual current protection
CCA	CENELEC Certification Agreement
CEN	Comité européen de normalisation; European Committee for Standardization
CENELEC	European Committee for Electrotechnical Standardization
CEP	Central earthing point
CFHC	Chlorofluorohydrocarbon
CHP	Combined heat and power station
CO	Carbon monoxide
CPS	Central power supply system

**D**

DaC	Data centre
DALI	Digital adressable lighting interface
DBO	Distribution boards intended to be operated by ordinary persons
DC	Direct current
DI	Residual current protection device (deprecated abbreviation), in conjunction with a fault interrupter (FI) now RCD
DIAZED	Diametrical two-part Edison screw-thread fuse
DIN VDE	Deutsche Industrie Norm Verband deutscher Elektrotechniker (German Industry Standard, Association of German Electrical Engineers)
DMT	Definite-time overcurrent-time protection
DMX	Digital multiplex, digital communication protocol for lighting control
DSO	Distribution system operator

1

2

3

4

5

6

7

8

9

10

11

12

13

14

15

16

17

**E**

EB	Electronic ballast
EC	Electronically commutated, e.g. for EC motor
ECG	Electrocardiogram
EEA	European Economic Area
EEG	Electroencephalogram
EEPROM	Electrically erasable, programmable read-only-memory
EEX	European Energy Exchange
EMG	Electromyogram
EMC	Electromagnetic compatibility
EN	European standard
ENEC	European norms electrical certification, a symbol indicating conformity with European safety standards
EnEV	Energy Saving Ordinance (Germany)
EnMS	Energy management system
EPROM	Erasable, programmable read-only-memory
ESD	Electrostatic discharge
ESPS	Emergency standby power system
ETU	Electronic trip unit

**F**

FGW	Fördergesellschaft Windenergie e. V. (German registered association promoting the utilisation of wind energy)
FI	Fault interrupter
FOC	Fibre-optic cable
FT	Functional test

**G**

GIS	Gas-insulated switchgear
-----	--------------------------

**H**

HVDC	High-voltage direct current transmission
HV HRC fuse	High-voltage high-rupturing-capacity fuse
HVAC	Heating, ventilation, air conditioning
HMI	Human machine interface
HOAI	Honorarordnung für Architekten und Ingenieure (German regulation of architects' and engineers' fees)
HRG	Harvard Research Group
HV	High voltage

**I**

I&C	Instrumentation and control
ICT	Information and communication technology
IDMTL	Inverse definite minimum time leakage
IEC	International Electrotechnical Commission
IEEE	Institute of Electrical and Electronics Engineers
IGBT	Insulated gate bipolar transistor
IR	Infrared
ISO	International Organization for Standardization
IT	Information technology
ITIC	Information Technology Industry Council

**L**

LDC	Light distribution curve
LED	Light emitting diode
LEMP	Lightning electro-magnetic pulse
LiTG	Lichttechnische Gesellschaft e. V. (German Light Engineering Society)
LLB	Low-loss ballast
LLMF	Lamp lumen maintenance factor
LMF	Luminaire maintenance factor
LMS	Light management systems
LPS	Low power system
LPZ	Lightning protection zone
LSC	Loss of service continuity
LSF	Lamp survival factor
LT-Si	Switch-disconnector with fuse
LV	Low voltage
LV HRC	Low-voltage high-rupturing-capacity fuse
LVMD	Low-Voltage Main Distribution

<b>M</b>		<b>P</b>	
MCB	Miniature circuit-breaker	PAS	Publicly available specification in connection with international standards
MCC	Motor control centre	PDS	Power drive system
MCCB	Moulded-case circuit-breaker	PFC	Power factor correction
MDNP	Main distribution board for normal power supply	PG	Power generating unit
MDSP	Main distribution board for safety power supply	PL	Performance level
MF	Maintenance factor	PoS	Point-of-sale
MID	Directive on Measurement Instruments 2004/22/EC	PRCD	Portable residual current protection device
MLAR	Sample Directive on Fireproofing Requirements for Conduits and Line Systems	PV	Photovoltaics
MRCB	Modular residual current device without integral current breaking device	PWM	Pulse width modulation
MSP	Motor start protection	<b>R</b>	
MTBF	Mean time between failure	RAM	Random access memory
MTTR	Mean time to repair	RCBO	Residual current operated circuit-breaker with overcurrent protector
MV	Medium voltage	RCCB	Residual current operated circuit-breaker (without integral overcurrent protection)
MVMD	Medium-voltage main distribution	RCD	Residual current device (previously FI)
<b>N</b>		RCU	Residual current unit, a variant of RCBO
NaS	Sodium-sulphur-battery (based on sodium sulphide: Na <sub>2</sub> S)	RDF	Rated diversity factor
NE	Neutral earthing	RESPE	Resonant neutral earthing (earth-fault compensation)
NOSPE	Low-impedance neutral earthing	RSMF	Room surface maintenance factor
NPS	Normal power supply	r.m.s.	Root mean square value
<b>O</b>		<b>S</b>	
OLED	Organic light emitting diode	SCADA	Supervisory control and data acquisition for technical processes, computer-based
		SCPD	Short-circuit protection device
		SEMP	Switching electromagnetic pulse
		SF <sub>6</sub>	Sulphur hexafluoride
		SIL	Safety integrity level
		Si-LT	Fuse-switch-disconnector
		SL	Standby light
		SPD	Surge protection device
		SPOF	Single point of failure
		SPS	Safety power supply
		SRCD	Socket-outlet residual current protection device

1

2

3

4

5

6

7

8

9

10

11

12

13

14

15

16

17

**T**

---

TAB	Technical supply conditions (Germany)
THD <sub>i</sub>	Total harmonic distortion of load current
TIP	Totally Integrated Power
TMTU	Thermal magnetic trip unit
TU	Transportation unit

**U**

---

UCTE	Union for the Co-ordination of Transmission of Electricity
UGR	Unified glare rating
UL	Underwriters Laboratories
UPS	Uninterruptible power supply
UV	Ultraviolet

**V**

---

VDN	Verband der Netzbetreiber e. V. (Registered Association of Network Operators, Germany)
VFD	Voltage and frequency dependent, off-line UPS
VFI	Voltage and frequency dependent, on-line UPS
VI	Voltage-independent, line-interactive UPS

**X**

---

XDMT	General for either DMT or IDTML protection
------	--

**Z**

---

ZSI	Zone-selective interlocking
-----	-----------------------------

## 17.4 Bibliography

No.	Year	Published by Authors/Series	Title
1	2013	German Federal Ministry of Economics and Technology	Verordnung über die Honorare für Architekten und Ingenieurleistungen (HOAI)
2	2011	Kiank/Fruth	Planning Guide for Power Distribution Plants
3	2009	Uptime Institute	Data Center Site Infrastructure Tier Standard: Topology
4	2000	Information Technology Industry Council TC3	ITIC (CBEMA) Curve Application Note
5	2007	VEÖ, VSE, CSRES, VDN, VWEW	D-A-CH-CZ – Technische Regeln zur Beurteilung von Netzrückwirkungen
6	2004	Official Journal of the European Union	"L390/24 Directive 2004/108/EC of the European Parliament and of the Council on the approximation of the laws of the Member States relating to electromagnetic compatibility and repealing Directive 89/336/EEC"
7	2005	A. Held	Oracle 10g Hochverfügbarkeit
8	2013	German Federal Office for Information Security	HV-Kompendium V 1.6 Band G 1: Einführung
9	2005	H. Schau	Schutz vor Störlichtbögen – II. Workshop Elektrische Sicherungen, Ilmenau
10	1976	F. Pigler	Druckbeanspruchung der Schaltanlagenräume durch Störlichtbögen, Energiewirtschaftliche Tagesfragen Vol. 26, No. 3
11	2008	BDEW	Whitepaper „Anforderungen an sichere Steuerungs- und Telekommunikationssysteme“
12	2003	ZVEI	Unterbrechungsfreie Stromversorgung, 2nd edition
13	2011	VDE-FNN	VDE-AR-N 4105: Erzeugungsanlagen am Niederspannungsnetz – Technische Mindestanforderungen für Anschluss und Parallelbetrieb von Erzeugungsanlagen am Niederspannungsnetz
14	2007	BDEW	Technische Anschlussbedingungen TAB 2007 für den Anschluss an das Niederspannungsnetz
15	2008	BDEW	Technischen Richtlinien Erzeugungsanlagen am Mittelspannungsnetz (and Supplements 1 to 4)
16	2008	BDEW	Technischen Anschlussbedingungen Mittelspannung
17	2013	Fördergesellschaft Windenergie	Technische Richtlinien Teil 3: Bestimmung der Elektrischen Eigenschaften von Erzeugungseinheiten am Mittel-, Hoch- und Höchstspannungsnetz
18	2010	Germanischer Lloyd	Guideline for the Certification of Wind Turbines, Edition 2010 (GL 2010)
19	2012	Germanischer Lloyd	Guideline for the Certification of Wind Turbines, Edition 2012 (GL 2012)
20	2010	M. Weiß	Datenauswertung von Energiemanagementsystemen
21	2009	ZVEI	Guide for DIN 12464-1 (German)
22	2013	ZVEI	Guide – Reliable Planning with LED Lighting
23	2009	Federal Law Gazette (Germany) 2009 Part I No. 23 (BGBl I 2009 Nr. 23)	Ordinance on the Amendment of the Energy Saving Ordinance (EnEV 2009)
24	2013	Federal Law Gazette (Germany) 2013 Part I No. 67 (BGBl I 2013 Nr. 67)	Second Ordinance on the Amendment of the Energy Saving Ordinance (EnEV 2014)
25	2012	ZVEI	Photobiological Safety of Lighting Products
26	2008	licht.de	licht.wissen (the licht.de series of publications) No. 1 – Lighting with Artificial Light
27	1988	LiTG Publication No. 3.5	Projektierung von Beleuchtungsanlagen nach dem Wirkungsgradverfahren

# 17.5 Conversion Factors and Tables

**Conductor cross sections in the Metric and US System**

Metric cross sections acc. to IEC	American Wire Gauge (AWG)	
	Equivalent metric CSA	AWG or MCM
Conductor cross section	Equivalent metric CSA	AWG or MCM
in mm <sup>2</sup>	in mm <sup>2</sup>	
0.75	0.653	19 AWG
	0.832	18
	1.040	17
	1.310	16
1.50	1.650	15
	2.080	14
2.50	2.620	13
	3.310	12
4.00	4.170	11
	5.260	10
6.00	6.630	9
	8.370	8
10.00	10.550	7
	13.300	6
16.00	16.770	5
	21.150	4
25.00	26.670	3
	33.630	2
35.00	42.410	1
50.00	53.480	1/0
70.00	67.430	2/0
95.00	85.030	3/0
120.00	107.200	4/0
150.00	126.640	250 MCM
	152.000	300
185.00	202.710	400
240.00	253.350	500
300.00	304.000	600
	354.710	700
400.00	405.350	800
500.00	506.710	1000
625.00		

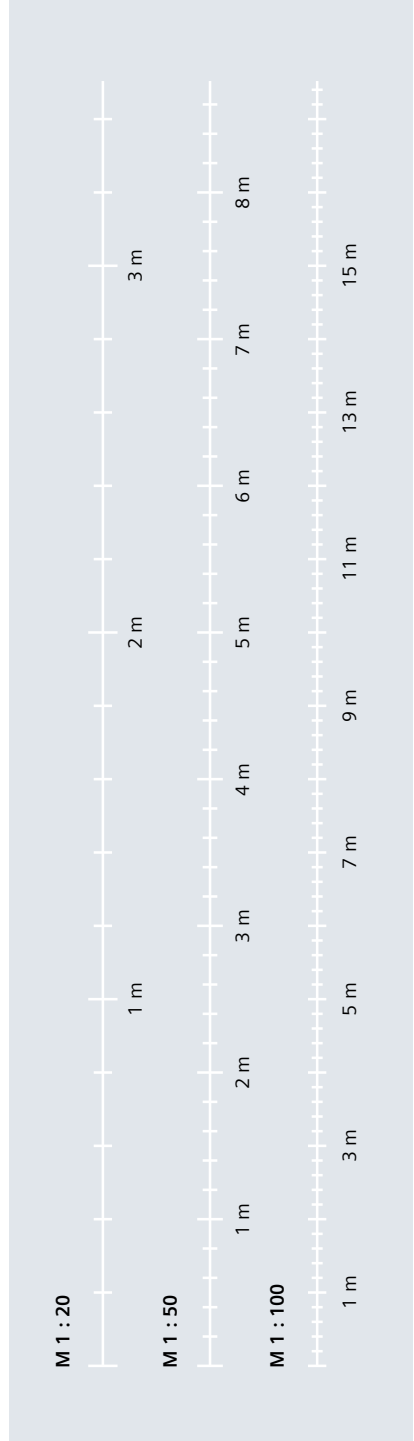
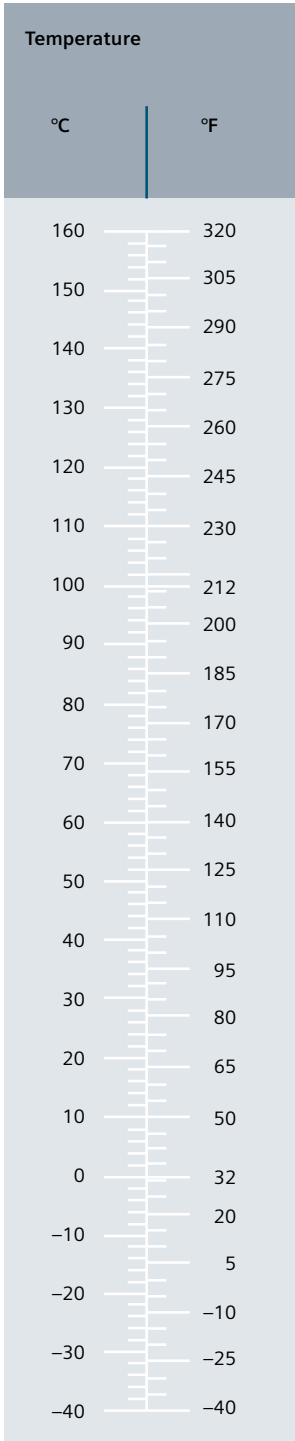

Linear measure	
SI unit	Non-metric unit
1 mm	39.37 mil
1 cm	0.394 in
1 m	3.281 ft = 39.370 in = 1.094 yd
1 km	0.621 mile = 1.094 yd
Non-metric unit	SI unit
1 mil	0.0254 mm
1 in	2.54 cm = 25.4 mm
1 ft	30.48 cm = 0.305 m
1 yd	0.914 m
1 mile	1.609 km = 1,609 m

Volume	
SI unit	Non-metric unit
1 cm <sup>3</sup>	0.061 in <sup>3</sup> = 0.034 fl. oz
1 dm <sup>3</sup> = 1 l	61.024 in <sup>3</sup> = 0.035 ft <sup>3</sup> = 1.057 quart = 2.114 pint = 0.264 gallon
1 m <sup>3</sup>	6.29 barrel
Non-metric unit	SI unit
1 in <sup>3</sup>	16.387 cm <sup>3</sup>
1 ft <sup>3</sup>	28.317 dm <sup>3</sup> = 0.028 m <sup>3</sup>
1 yd <sup>3</sup>	0.765 m <sup>3</sup>
1 fl. oz.	29.574 cm <sup>3</sup>
1 quart	0.946 dm <sup>3</sup> = 0.946 l
1 pint	0.473 dm <sup>3</sup> = 0.473 l
1 gallon	3.785 dm <sup>3</sup> = 3.785 l
1 barrel	159 dm <sup>3</sup> = 0.159 m <sup>3</sup> = 159 l

Square measure	
SI unit	Non-metric unit
1 mm <sup>2</sup>	0.00155 in <sup>2</sup>
1 cm <sup>2</sup>	0.155 in <sup>2</sup>
1 m <sup>2</sup>	10.76 ft <sup>2</sup> = 1,550 in <sup>2</sup> = 1.196 yd <sup>2</sup>
1 km <sup>2</sup>	0.366 mile <sup>2</sup>
Non-metric unit	SI unit
1 in <sup>2</sup>	6.452 cm <sup>2</sup> = 645.16 mm <sup>2</sup>
1 ft <sup>2</sup>	0.093 m <sup>2</sup> = 929 cm <sup>2</sup>
1 yd <sup>2</sup>	0.836 m <sup>2</sup>
1 acre	4,046.9 m <sup>2</sup>
1 mile <sup>2</sup>	2.59 km <sup>2</sup>

Volume flow rate	
SI unit	Non-metric unit
1 l/s	0.264 gallon/s
1 l/h	0.0044 gallon/min
1 m <sup>3</sup> /h	4.405 gallon/min = 0.589 ft <sup>3</sup> /min = 0.0098 ft <sup>3</sup> /s
Non-metric unit	SI unit
1 gallon/s	3.785 l/s
1 gallon/min	0.227 m <sup>3</sup> /h = 227 l/h
1 ft <sup>3</sup> /s	101.941 m <sup>3</sup> /h
1 ft <sup>3</sup> /min	1.699 m <sup>3</sup> /h

Btu = British thermal unit  
 Btu/h = British thermal unit / hour  
 kgf = kilogram force  
 lbf = pound force  
 tonf = ton force

1

2

3

4

5

6

7

8

9

10

11

12

13

14

15

16

17

Force	
SI unit	Non-metric unit
1 N	0.225 lbf = 0.102 kgf
1 kN	0.100 tonf
Non-metric unit	SI unit
1 lbf	4.448 N
1 kgf	9.807 N
1 tonf	9.807 kN

Torque, moment of force	
SI unit	Non-metric unit
1 Nm	8.851 lbf in = 0.738 lbf ft (= 0.102 kgf m)
Non-metric unit	SI unit
1 lbf in	0.113 Nm = 0.012 kgf m
1 lbf ft	1.356 Nm = 0.138 kgf m

Moment of inertia	
Numerical value equation $J = \frac{GD^2}{4} = Wr^2$	
SI unit	Non-metric unit
1 kg m <sup>2</sup>	23.73 lb ft <sup>2</sup>
Non-metric unit	SI unit
1 lb ft <sup>2</sup>	0.04214 kg m <sup>2</sup>

Velocity	
SI unit	Non-metric unit
1 m/s	3.281 ft/s = 2.237 mile/h
1 km/h	0.911 ft/s = 0.621 mile/h
Non-metric unit	SI unit
1 ft/s	0.305 m/s = 1.097 km/h
1 mile/h	0.447 m/s = 1.609 km/h

Pressure	
SI unit	Non-metric unit
1 bar = 10 <sup>5</sup> Pa = 10 <sup>2</sup> kPa	29.53 in Hg = 14.504 psi = 2,088.54 lbf/ft <sup>2</sup> = 14.504 lbf/in <sup>2</sup> = 0.932 tonf/ft <sup>2</sup> 6.457 × 10 <sup>-3</sup> tonf/in <sup>2</sup> (= 1.02 kgf/cm <sup>2</sup> )
Non-metric unit	SI unit
1 in HG	0.034 bar
1 psi	0.069 bar
1 lbf/ft <sup>2</sup> 1 lbf/in <sup>2</sup>	4.788 × 10 <sup>-4</sup> bar = 4.882 × 10 <sup>-4</sup> kgf/cm <sup>2</sup>
1 tonf/ft <sup>2</sup>	0.069 bar = 0.070 kgf/cm <sup>2</sup>
1 tonf/in <sup>2</sup>	1.072 bar = 1.093 kgf/cm <sup>2</sup>
	154.443 bar = 157.488 kgf/cm <sup>2</sup>

Mass, weight	
SI unit	Non-metric unit
1 g	0.035 oz
1 kg	2.205 lb = 35.27 oz
1 t	1.102 sh ton = 2,205 lb
Non-metric unit	SI unit
1 oz	28.35 g
1 lb	0.454 kg = 453.6 g
1 sh ton	0.907 t = 907.2 kg

Specific steam consumption	
SI unit	Non-metric unit
1 kg/kWh	1.644 lb/hp h
Non-metric unit	SI unit
1 lb/hp h	0.608 kg/kWh



Energy, work, heat content	
SI unit	Non-metric unit
1 kWh	1.341 hp h = 2.655 kgf m
1 J	= $3.6 \times 10^5$ J
1 kgf m	$3.725 \times 10^{-7}$ hp h = 0.738 ft lbf = $9.478 \times 10^{-4}$ Btu (= $2.388 \times 10^{-4}$ kcal)
	$3.653 \times 10^{-6}$ hp h = 7.233 ft lbf
Non-metric unit	SI unit
1 hp h	0.746 kWh = $2.684 \times 10^6$ J
1 ft lbf	= $2.737 \times 10^5$ kgf m
1 Btu	0.138 kgf m 1.055 kJ = 1,055.06 J (= 0.252 kcal)

Electrical power	
SI unit	Non-metric unit
1 kW	1.341 hp = 101.972 kgf m/s (= 1.36 PS)
1 W	0.738 ft lbf/s = 0.86 kcal/h = 3.412 Btu (= 0.102 kgf m/s)
Non-metric unit	SI unit
1 hp	0.746 kW = 745.70 W = 76.040 kgf m/s
1 ft lbf/s	(= 1.014 PS)
1 kcal/h	1.356 W (= 0.138 kgf in/s)
1 Btu/h	1.163 W
	0.293 W

Temperature		
SI unit	Non-metric unit	
°C	→ °F $\frac{9}{5} \cdot \partial_C + 32 = \partial_F$	
K	→ °F $\frac{9}{5} \cdot T - 459.67 = \partial_F$	
Non-metric unit	SI unit	
°F	→ °C $\frac{5}{9} (\partial_F - 32) = \partial_C$	
°F	→ K $\frac{5}{9} (\partial_F + 459.67) = T$	
Note:		
Quantity	Symbol	Unit
Temperature in degrees Fahrenheit	$\partial_F$	°F
Temperature in degrees Celsius	$\partial_C$	°C
Thermodynamic temperature in Kelvin	T	K

Examples of decimal multiples and fractions of metric units
1 km = 1,000 m; 1 m = 100 cm = 1,000 mm
1 km <sup>2</sup> = 1,000,000 m <sup>2</sup> ; 1 m <sup>2</sup> = 10,000 cm <sup>2</sup> ; 1 cm <sup>2</sup> = 100 mm <sup>2</sup>
1 m <sup>3</sup> = 1,000,000 cm <sup>3</sup> ; 1 cm <sup>3</sup> = 1,000 mm <sup>3</sup>
1 t = 1,000 kg; 1 kg = 1,000 g
1 kW = 1,000 W

Btu = British thermal unit  
 Btu/h = British thermal unit/hour  
 kgf = kilogram force  
 lbf = pound force  
 tonf = ton force

Our thanks go to Siteco Beleuchtungstechnik GmbH (lighting systems) and CEAG Notlichtsysteme GmbH (safety lighting) for their expert support in compiling this manual.

## Imprint

Totally Integrated Power – Consultant Support  
Planning of Electric Power Distribution  
Technical Principles

### Published by

Siemens AG  
Energy Management  
Medium Voltage & Systems

### Editor

Siemens AG  
Dr. Siegbert Hopf  
E-Mail: siegbert.hopf@siemens.com

### Technical Support

Ulrike Fleischmann, Wolfgang Fruth, Ralf Gluth,  
Birgitta Grandjean, Jasmin Gruner, Thomas Klimiont,  
Wolfgang Peter, Frank Scheunert, Manfred Weiß

### Translation

Albani translations  
Äußere Brucker Str. 51  
D-91052 Erlangen

### Publishing House

Publicis Pixelpark  
Nägelsbachstr. 33  
D-91052 Erlangen

### Print

Beltz Bad Langensalza GmbH  
Neustädter Straße 1-4  
D-99947 Bad Langensalza

### Image Rights

All images and graphics © Siemens AG.

© 2016 Siemens AG

Berlin and Munich

All rights reserved.

All data and circuit examples without engagement.

Subject to change without prior notice.

The omission of any specific reference with regard to trademarks, brand names, technical solutions, etc. does not imply that they are not protected by patent.



**Published by**

© Siemens AG 2016  
Energy Management  
Medium Voltage & Systems  
Mozartstr. 31c  
D-91052 Erlangen, Germany

For more information please contact  
E-mail: [consultant-support.tip@siemens.com](mailto:consultant-support.tip@siemens.com)

Article No.: EMMS-T10007-00-7600  
Printed in Germany  
Dispo 27612  
08161.0

All rights reserved.  
Nominal fee of €3.  
All data and circuit examples without engagement.

Subject to changes and errors. The information given in this document only contains general descriptions and/or performance features which may not always specifically reflect those described, or which may undergo modification in the course of further development of the products. The requested performance features are binding only when they are expressly agreed upon in the concluded contract.

DIAZED, DYNAVERT, FITformer, NEOZED, NXACT, SENTRON, SICAM, SIMARIS, SIMOVERT, SINCAL, SIPROTEC, SIRIUS, SITOR, SIVACON, Totally Integrated Power (TIP), TUMETIC, TUNORMA are registered trademarks of Siemens AG. Any unauthorized use is prohibited. All other designations in this document may represent trademarks whose use by third parties for their own purposes may violate the proprietary rights of the owner.