

National Metering Installation Requirements

Draft: June 2020

The CMIG would like to acknowledge the support of the following organisations in the development of these requirements.



Foreword

On 1 December 2017, the coordination of the installation of metering equipment in the National Electricity Market (NEM) (excluding Victoria) became the responsibility of Electricity Retailers who nominate and contract the NEM roles of Metering Coordinators and Metering Providers to perform the metering works. Prior to this date, small customer metering was the responsibility of the local electricity distributor or their agent, with the requirements for *Metering Installations* included in jurisdictional or electricity distributor specific Service and Installation Rules.

To support the efficient operation of the market, the competitive metering industry is seeking to proactively align to develop the underlying standards and work practices required to deliver a safe and accurate *Metering Installation*.

These *Metering Installation* Requirements (Requirements) have been developed by the members of the Competitive Metering Industry Group (CMIG) MIR Working Group (MIR-WG) and supersedes the metering requirements previously included in Service and Installation Rules (excluding Victoria). This edition of these Requirements will commence operation in each Jurisdiction in accordance with Section 7 - Specific Jurisdictional Requirements and *Shall* apply to all *Metering Installations* in the NEM.

These Requirements form the major part of a Metering Providers' technical requirements as referred to in the National Electricity Rules (NER) and draw heavily on the requirements previously published by distribution businesses. These Requirements have been subject to industry consultation during their development and provide industry agreed specifications intended to assist manufacturers, distributors, retailers, customers and customers' agents to meet their regulatory and electricity supply obligations.

Whilst care has been taken in their preparation, these Requirements may not cover all circumstances. This may include unusual connections, inadvertent omissions or changes to legislation and codes. The CMIG does not accept responsibility where this occurs. The relevant Metering Provider must be consulted in these circumstances.

Revision History

Version	Comment	Date
Draft 1	Initial release to MIR-WG based on content transferred to CMIG from Queensland QEMM.	03/04/2019
Draft 2	Further release to MIR-WG incorporated input from MIR-WG two full day face to face workshops in Sydney on April 30 th and May 1 st 2019 resulting in a major rewrite of several sections. Includes first attempt to include historical requirements from NSW, SA, Tas and Vic.	08/06/2019
Draft 3	Further release to MIR-WG incorporated further input from MIR-WG collected during full day face to face workshops in Brisbane on 04/07/2019 and Sydney on 24/07/2019 which resulted in a major rewrite of meter panel/enclosure, metering neutral and communications requirements Includes first attempt at new panel layout drawings for MIR-WG comment.	25/09/2019
Draft 4	Further release to MIR-WG and Industry for comment which incorporates further input from MIR-WG collected during teleconference workshops on 17/10/2019 and 18/10/2019. Includes more refined version of panel layout drawings	31/10/2019
Draft 5	Added initial draft of LV CT metering requirements for discussion by MIR working group.	09/12/2019
Draft 5.1	Updates to LV CT section as a result of workshop on 11/12/2019. Old ESAA test block standard reproduced in new Appendix C	01/03/2020
Draft 6	Updates following public consultation on draft 4 Updates to LV CT section Added Tasmanian requirements	07/05/2020
Draft 6.1	Updates after workshop on 14/05/2020	28/05/2020
1.0	Initial release Includes updates to drawings in Appendix B & C	30/06/2020

Table of Contents

Foreword	2
Revision History.....	3
1 Introduction.....	8
1.1 Scope.....	8
1.2 Failure to comply with these Requirements	8
1.3 Innovation.....	8
1.4 Definitions	8
1.4.1 Metering Installation Requirements.....	8
1.5 Exceptional Circumstances.....	9
1.6 Historic Buildings.....	9
1.7 Responsibility for Equipment.....	9
1.8 Alterations	10
1.9 Repairs.....	10
1.10 Metering Determination.....	11
1.10.1 Current Transformer Selection.....	12
2 Access and Security	13
2.1 Access to Metering Equipment	13
2.2 Locking Facilities.....	13
2.3 Metering Providers Security Seal.....	13
3 Metering Panels, Surrounds and Enclosures	14
3.1 General	14
3.2 Meter Panels.....	14
3.2.1 Fixing Arrangements	14
3.2.2 Labelling.....	14
3.2.3 Wiring	15
3.2.4 Wiring Holes.....	15
3.3 Mounting of Equipment	15
3.4 Metering Surrounds and Enclosures.....	16
3.4.1 General	16
3.4.2 Temperature Rise Considerations	16
4 Whole Current Metering	17
4.1 General requirements	17
4.2 Metering Equipment Protection and Isolation	17
4.2.1 Protection of Whole Current Metering.....	17
4.2.2 Discrimination / Selectivity with MPD	18
4.2.3 Isolation of Whole Current Metering.....	18
4.2.4 De-loading of Whole Current Metering.....	18

4.3	Metering and Control Equipment – Spacing Requirements	19
4.3.1	General	19
4.3.2	Sizes of equipment to be accommodated	19
4.3.3	Minimum Metering Equipment Combinations	20
4.3.4	Provision for Distributor Equipment.....	21
4.3.5	Equipment dimension and placement examples.....	22
4.4	Whole Current Meter Wiring.....	28
4.5	Metering Active and Neutral Requirements	28
4.5.1	Connection of Metering Neutral Conductors to Main Neutral.....	28
4.5.2	Metering Active and Neutral Links	29
4.5.3	Metering Active and Neutral Link Mounting	29
4.5.4	Metering Active and Neutral Link Labelling.....	29
4.6	Metering requirements for a Builder’s Temporary Service (BTS)	29
4.7	Plug-in Metering	30
4.8	Metering Communications	30
4.8.1	General	30
4.8.2	Segregation of wiring	30
4.8.3	Location of Equipment	30
4.8.4	Customer and third party provided Communication Equipment.....	31
5	Low <i>Voltage</i> Current Transformer Metering	32
5.1	General Requirements	32
5.2	Isolation.....	32
5.3	Typical Current Transformer Dimensions	33
5.4	Current Transformer Chambers	33
5.5	Current Transformer Installation Requirements	35
5.6	Voltage Circuit Protection & Isolation.....	35
5.6.1	Fuses in Current Transformer Chambers	35
5.6.2	Fuses on Meter Panels	36
5.7	Current Transformer Metering Panels.....	36
5.8	Spacing between Meters and Heavy Current Carrying Conductors	36
5.8.1	Grouped Conductors.....	36
5.8.2	Separated Conductors	37
5.9	Current Transformer Metering Test Block.....	37
5.10	Wiring to Current Transformers, Test Blocks etc.	38
5.11	Changes to Existing Current Transformer Metering Installations.....	39
6	High <i>Voltage</i> Metering.....	40
7	Specific Jurisdictional Requirements and Transitional Arrangements.....	41
7.1	Queensland.....	41
7.1.1	Card Operated Metering	41
7.2	New South Wales.....	42
7.3	South Australia.....	42
7.4	Tasmania	42

7.4.1	Background.....	42
7.4.2	New Installations and consumer-initiated works	43
7.4.3	Repairs and faults	44
7.4.4	Metering Protection	44
7.4.5	Location of Panels.....	44
7.5	Australian Capital Territory.....	45
7.6	Victoria	45
Appendix A – Typical Panel Layouts		46
Single Occupancies.....		46
Multiple Occupancies		49
Current Transformer Metering		58
Appendix B – Low Voltage CT Layouts		59
General Arrangements for Metering Fuse Sealing Blocks		59
Chamber Arrangements – Single Occupancy		60
Wiring Diagram – LV CT Metering Connections.....		61
Appendix C – Specification for Test Blocks for Transformer-Operated Meters		62
1	Scope	62
2	Type	62
3	General Construction	63
4	Terminals.....	63
5	Cover.....	63
6	Sealing	63
General Arrangements for Metering Test Blocks		64

Table of Tables

Table 1 - Typical Load Groups for Low Voltage Metering.....	11
Table 2 – Space Requirements for Equipment.....	19
Table 3 – Metering Equipment to be Accommodated.....	20
Table 4 - Typical Current Transformer Maximum Dimensions.....	33
Table 5 - Spacing between revenue meters/meter wiring and conductors carrying heavy currents.....	37
Table 6 – Multi-Core Cable core designations.....	38
Table 7 – CT Secondary wiring size requirements.....	39

Table of Figures

Figure 1 – Time Current Curves (1) MPD 80AGg Fuse (2) De-loading Device C-curve 100A Breaker.....	18
Figure 2 - Meter Protection / Isolation Devices.....	22
Figure 3 - Distributor/Network Equipment.....	22
Figure 4 - Single Phase Meter.....	23
Figure 5 - Three Phase Meter.....	23
Figure 6 - Minimum Distance from edge of Panel.....	24
Figure 7 - Distributor Equipment with Isolation link.....	25
Figure 8 - Single Phase meter with Isolation Link.....	26
Figure 9 - Three Phase meters with Isolation links.....	27
Figure 10 - CT Chamber general dimensions.....	34
Figure 11 - Typical Panel Layout for Residential House with Multi-phase, single phase meters and load control.....	46
Figure 12 - Typical Panel Layout for Residential House with Multi-phase meter.....	47
Figure 13 - Typical Panel Layout for Residential House with two single phase meters and load control.....	48
Figure 14 - Typical Panel Layout for Multi Occupancy, Single phase, 1200 x 600 panel.....	49
Figure 15 - Typical Panel Layout for Multi Occupancy, multiphase, 1200 x 600 panel.....	50
Figure 16 - Typical Panel Layout for Multi Occupancy, Single phase, 1000 x 600 panel.....	51
Figure 17 - Typical Panel Layout for Multi Occupancy, multiphase, 1000 x 600 panel.....	52
Figure 18 - Typical Panel Layout for Multi Occupancy, Single phase, 800 x 600 panel.....	53
Figure 19 - Typical Panel Layout for Multi Occupancy, multiphase, 800 x 600 panel.....	54
Figure 20 - Typical Panel Layout for Multi Occupancy, Single phase, 600 x 600 panel.....	55
Figure 21 - Typical Panel Layout for Multi Occupancy, multiphase, 600 x 600 panel.....	56
Figure 22 - Typical Panel Layout for Multi Occupancy, multiphase and single phase, 560 x 575 panel.....	57
Figure 23 – Typical CT Meter Panel Equipment Placement.....	58
Figure 24 - General arrangement for metering fuse sealing blocks.....	59
Figure 25 - Typical CT chamber arrangements.....	60
Figure 26 - Wiring Diagram for CT Metering.....	61
Figure 27 Preferred Test Block Arrangement.....	64
Figure 28 Mk1 Test block configuration commonly used in QLD.....	65
Figure 29 Mk1 Test block configuration commonly used in NSW and ACT.....	65
Figure 30 Mk2 Test block configuration commonly used in Vic, SA and Tas.....	65

1 Introduction

The purpose of these Requirements is to provide a consistent approach to ensure that a customers' electrical *Metering Installation*, as defined in the NER, is safe during and after the installation of an advanced meter.

During the process of developing these Requirements, attempts have been made to align them to historical practices wherever possible while ensuring provision is made for current metering and distributor equipment.

These Requirements also seek to promote a consistent, NEM approach to *Metering Installation* and maintenance thus ensuring customers receive the most effective services, allowing metering businesses operating across state boundaries to operate with consistency and efficiency.

As Victoria has opted out of the *Small Customer Metering Competition Reform*, as a jurisdiction they do not fall under these Requirements as metering is still provided by distribution businesses. *Large customer* metering is subject to metering competition and is subject to these Requirements.

1.1 Scope

These Requirements apply to all new and alterations or additions to existing energy Whole Current and *low voltage* Current Transformer *Metering Installations* connected to the NEM and provides guidelines for metering arrangements of a customer's installation.

Requirements for High *Voltage* installations will be detailed in future versions of these Requirements.

Where departures or clarification from these Requirements may be necessary, prior consultation with the relevant Metering Provider is required. (Refer to clause 1.5)

1.2 Failure to comply with these Requirements

These Requirements are additional and are not intended to over-ride AS/NZS 3000 Wiring Rules. Customers whose installations do not comply with these Requirements may have the installation of metering equipment delayed or withheld until the non-compliant circumstances have been rectified

1.3 Innovation

These Requirements do not preclude alternative methods, innovation, or technology that achieves the same outcomes as the specifications detailed in this document. However, any such proposal requires approval by the respective Metering Coordinator and/or Metering Provider (Refer to clause 1.5).

1.4 Definitions

Any terms used within this document are consistent with the definitions in the NER and AS/NZS 3000 Wiring Rules.

1.4.1 Metering Installation Requirements

The general reference to these Metering Installation Requirements within this document is with the capitalised word 'Requirements'.

1.5 Exceptional Circumstances

In exceptional circumstances, parts of these Requirements may be waived and/or modified by the submission of a written request to the relevant Metering Provider.

The request *shall* include the following:

- A. A detailed statement of the reasons why non-compliance with these Requirements is sought.
- B. Full details and diagrams, as necessary, showing the specific aspect of a requested variation.
- C. The installations National Metering Identifier (NMI) and location details.

No action or variation *shall* be undertaken until a written approval from the Metering Provider has been given.

1.6 Historic Buildings

Compliance with these Requirements is generally expected in all circumstances, however, historic buildings may require elements of these Requirements to be waived and/or modified. (e.g. meter positions and panel design and sizing etc). In these cases, an application *shall* be made in accordance with section 1.5 of these Requirements.

1.7 Responsibility for Equipment

Provision *shall* be made for Metering equipment deemed to be necessary by the Metering Provider to record electricity consumption.

Customer-supplied equipment may form part of the *Metering Installation*. All equipment that forms part of the *metering installation shall* be in accordance with these Requirements. The Metering Provider may require the customer to carry out certain activities on their equipment or facilities to ensure the Metering Installation remains compliant with the requirements in the NER.

Network Devices deemed to be necessary to control electricity consumption that are supplied by the distributor, *shall* be maintained and remain the property of the distributor and installed in accordance with the requirements of the Distributor.

For safety and security reasons, all whole-current meters and Network Device terminals *shall* be connected directly to isolating devices. These devices may be service/meter protection devices (*Fuses*), or metering isolation switches, or service/metering *Isolation* links (*Fuse* holders with a link).

Notes:

- Metering *Active/Neutral* links are distinct and different to customer's *Active/Neutral* and/or NEM links)
- On single dwellings, the network devices and metering equipment are connected to a common isolation device.

1.8 Alterations

Where a customer directs a retailer to request metering or tariff changes, any alterations to the customer's metering panel or meter enclosure *shall* be the customer's responsibility.

Unless otherwise agreed with the Metering Provider, where the customer initiates alterations, additions or relocation of existing metering, facilities that are in accordance with these Requirements *shall* be provided.

Examples of the scenarios of when *metering installations* are to be upgraded considering legacy arrangements in each jurisdiction are included in section 7 of these Requirements.

Any asbestos material that may create an Occupational Health & Safety risk *shall* be removed from the *Metering Installation*.

For example, where an existing timber or asbestos meter board or panel exists, it *shall* be replaced with a hinged *insulated* panel with appropriate design, size and clearances in accordance with these Requirements.

Where the location of the metering equipment is to be changed, it shall comply with the location requirements of the jurisdictional service and installation rules and:

- Have sufficient space to adequately accommodate the intended equipment complying with clause 4.3;
- Have minimum wiring space complying with clause 3 at the rear of the board or panel, and,
- Ensure that equipment that has been previously mounted on Asbestos material is treated as asbestos contaminated and is not be reused on new metering panels.

1.9 Repairs

The Metering Coordinator is responsible to ensure the customers connection point is metered in a manner that complies with the NER. Should the metering equipment require repair or replacement, the Metering Coordinator will appoint a Metering Provider to carry out the repair or install new metering equipment.

Should new metering equipment need to be installed, the Metering Provider may require that the customer upgrade their facilities to be either fully or partially be in accordance with these Requirements.

Examples of the upgrade scenarios considering legacy arrangements in each jurisdiction are included in section 7 of these Requirements.

In the case of natural disasters, these may be considered an exceptional circumstance as described in clause 1.5 of these Requirements and the Metering Provider may limit the upgrades required to the customers facilities in order to quickly reinstate the customers electricity supply after the natural disaster.

1.10 Metering Determination

Excluding *distributor* approved unmetered supply and AEMO registered Type 7 loads, all customer *Electrical Installations shall* be metered

- (a) in accordance with the NER,
- (b) In accordance with these Requirements,
- (c) to meet the Retail tariff requirements and
- (d) to meet the Network tariff requirements.

In the case of new connections, additions or alterations, the customer or their agent *shall* be responsible for determining the *Electrical Installation's* load requirements, and method of metering (i.e. whole current or current transformer metering or high voltage metering). Table 1 provides guidance on the typical load groups for low *Voltage* metering.

Calculated Maximum Demand per AS/NZS 3000 for Connection point for Metering per phase	CT requirements	Metering Equipment
LV 0 - 100A	None	Whole Current meter single or three phase
LV >80 to 400 A	Type S 200/5 metering extended 200% range Current Transformer with 5VA burden rating	CT Meter
LV between >200 - 1600 A	Type T 800/5 metering extended 200% range Current Transformer with 15VA burden rating	CT Meter
LV between >800 – 3000 A	Type W 1500/5 metering extended 200% range Current Transformer with 15VA burden rating	CT Meter
LV between >1500 – 4000 A	Type U 2000/5 metering extended 200% range Current Transformer with 15VA burden rating	CT Meter

Table 1 - Typical Load Groups for Low Voltage Metering

Note: Whole Current metering equipment intended to be installed at the interface to the public electricity distribution network in Australia is designed to comply with AS62052.31. This standard

requires that the metering equipment be protected by an 80 Amp HRC Type 11b Fuse manufactured in accordance with AS 60269.3.0 and AS 60269.3.1. Fuses manufactured to this standard will adequately protect the smart meter and its supply control switch from a short circuit fault, but still tolerate 100A for an extended period of time.

The customer *shall* notify their Retailer if the load of their installation is exceeding the limits for the metering equipment shown in Table 1. The customer shall take steps to either reduce their load such that it is within the limits of Table 1 or have the Metering Installation upgraded such that it is sufficient for the installations load requirements.

The customer or their agent should consult with the customer's Retailer at the earliest opportunity in order to determine their Retail Tariff / Network Tariff and Metering requirements.

1.10.1 Current Transformer Selection

Current Transformers to be installed in low voltage switchboards that form part of the *metering installation*, *shall* be manufactured and type tested to AS60044.1–2007 Class 0.5S with the availability of a Type Test Certificate. Each Current Transformer *shall* be supplied with an accuracy test report from an accredited NATA or other accredited body that is a signatory to the ILAC MRA and can achieve measurement uncertainty of $\pm 0.1\%$ amplitude and ± 0.1 crad phase error, based on 95% confidence level. Minimum test points *shall* include 5%, 20%, 100% and maximum primary rating and secondary unity power factor burden of 25% rated)

In selecting the Current Transformer rating, consideration *shall* be given to ensuring the CT rating selection adequately accommodates the foreseeable maximum current of the measured circuit. In the absence of a justifiable alternative, the default *shall* be the maximum current capacity of the measured circuit.

The selection of Current Transformers to operate at the limit of their extended range (e.g. 200/5 CT with 200% extended range, selected for a 400A load) eliminates any scope for load growth. If the customer's future load exceeds the maximum rated load current for the CT, the metering installation becomes non-compliant with the NER, and the Current Transformers will require upgrade – together with the required supply interruption and potential switchboard upgrade. Therefore, it is recommended to select a Current Transformer with a margin for future load growth.

2 Access and Security

2.1 Access to Metering Equipment

A customer shall provide the Metering Provider a safe and unhindered access to their Metering Installation for any purposes associated with the metering of electricity and testing of the customer's *Electrical Installation* including connection, interruption, disconnection or reconnection of supply.

Acceptable locations for the *Metering Installation* are detailed in jurisdictional Service and Installation Rules (SIR's).

Equipment *shall* be mounted at heights such that it is *readily accessible* and allows safe access to read and maintain the equipment and *shall* be in accordance with AS/NZS 3000 Wiring Rules section on Location of Switchboards.

Examples of acceptable mounting heights for equipment from the floor or platform are:

- Revenue meters- Min 600mm and Max 2000mm (from ground/platform level) to the bottom or top of the device respectively.
- De-loading devices & communications Equipment - Min 300mm and Max 2100mm to the operating mechanism. Antennae equipment Refer to clause 4.8.
- MIL/MPD & meter *Neutral* links - Min 400mm and Max 2000mm to the operating mechanism.
- Network control devices - Min 600mm and Max 1800mm or per the Distributors requirements (SIR's)

2.2 Locking Facilities

Where the Metering Provider's metering equipment is enclosed or within a low security area that the customer wishes to secure with a lock, access to the area or *enclosure* must be fitted with an approved lock which is compatible with the relevant industry locking system.

2.3 Metering Providers Security Seal

The NER requires that *Metering Installations* have facilities to keep them secure from interference. Provision *shall* be made for the application of security seals to any un-metered portion of a *Metering Installation*.

Sufficient access *shall* be allowed for sealing each point and in any case not less than 25mm clearance around each sealing point. Escutcheon panels which provide access to un-metered sections or terminals of switchboards *shall* also be provided with sealing facilities. Sealing facilities *should not* rely on holes to be aligned through nuts and threaded studs.

Provision *shall* be made for the sealing of all Current Transformer metering panels, dedicated Current Transformer and Voltage Transformer chambers and High Voltage metering panels.

3 Metering Panels, Surrounds and Enclosures

3.1 General

Switchboards and surrounds *shall* be suitable to withstand the mechanical, electrical and thermal stresses that are likely to occur in service and the environments in which it is to be installed. All metering panels, *enclosures*, surrounds and supplementary equipment *shall* comply with AS/NZS 3000 Wiring Rules. Switchboards complying with the relevant requirements of AS/NZS 61439 series are considered to meet the requirements of these rules.

Meter mounting facilities *shall* be provided that are of a type and in a location, *accessible* and prepared for the meter's installation:

- in a metering *enclosure* within the customer's *Switchboard* equipment; or
- in a meter only *enclosure*; or on a surround; or
- within or on facilities that are acceptable to the Metering Provider. (Refer to clause 1.5 for exemptions)

3.2 Meter Panels

Meter panels *shall* be constructed of insulating material:

- to an equal or better standard than that required by AS/NZS 61439.1;
- All meter panel materials must comply with the glow-wire test to 650°C according to AS/NZS 61439.1.

3.2.1 Fixing Arrangements

The meter panel *shall* be:

- hinged mounted on one vertical edge of the panel and secured to the metering *enclosure* or surround;
- capable of being opened to an angle of not less than 90 degrees from the closed position with all metering equipment installed;
- equipped with hinges:
 - constructed of a suitable non-corroding material that will maintain a structural and dimensional fit after metering equipment has been installed;
 - of a removable type with double off-set for meter panels installed within *enclosures*;
 - of a removable type for meter panels on surrounds;
- secured in the closed position by a fastener/s which requires the use of a tool to release; and
- be able to be easily fitted with a seal to seal the panel in the closed and fastened position. A 1.6mm – 2mm diameter hole is to be provided for the attachment of a seal.

3.2.2 Labelling

Where the metering installations for multiple occupancies occur at the same street addresses, each of the occupancies metering *shall* be labelled or identified in a manner acceptable to the Metering Provider. Labels *shall* be displayed on the metering panel to indicate the relationship of meters, *fuses*

and other equipment.

Every label required by these Requirements *shall* be permanent, indelible, legible and suitable for the purpose for which it is intended. For example, labels *should* be of laminate and manufactured with letters and numbers of not less than 6mm in height.

3.2.3 Wiring

Meter panels *shall* be wired in accordance with these Requirements or the Metering Provider specifications and the AS/NZS 3000 Wiring Rules. Unused meter wiring must be terminated in accordance with AS/NZS 3000 Wiring Rules. Acceptable methods to comply with these Requirements include the fitting of all intended metering equipment to the panel at the same time, or to ensure unused wiring is appropriately *insulated* and terminated at the rear of the panel or within a junction box.

All *Conductors* connected to metering equipment on the metering panel *shall* be;

- provided with sufficient free length to allow the panel to be moved into a position to enable work to be carried out;
- suitably fixed or otherwise retained in position to avoid undue movement or stress at terminals of metering/electrical equipment when the panel is moved or is fixed in position; and
- arranged to prevent undue pressure on *electrical equipment* mounted behind the panel or risk of being sandwiched between panel and surround.

3.2.4 Wiring Holes

Metering Providers may install a variety of metering equipment that may require wiring holes in different locations. There is no requirement to pre-drill holes in the meter panel.

Holes for ELV and communications cabling *shall* be separate from LV *Cable* holes. Refer to AS/NZS 3000 Wiring Rules section on “Prevention of mutual detrimental effects between services for requirements for communication cabling”.

3.3 Mounting of Equipment

The meter panel is dedicated for revenue *metering equipment*, *Network Devices* and customer equipment directly associated with supply and isolation of the metering system.

Examples of equipment permitted on the meter panel include:

- Service Protection Device (SPD),
- Meter Isolation Link (MIL).
- Switches or Circuit Breakers used as main switches
- Customer owned neutral or active links on the back of the panel and
- Load contactors controlled by the metering equipment or network devices.

Customer owned GPO's and sub-circuit protection are not permitted to be mounted on the metering panel.

Bolts/screws used to mount and fix equipment on *insulated* meter panels *shall* be fit for purpose. Fixing screws and fasteners *shall* not protrude through the rear of the panel in a manner that could damage *conductors* or create un-earthed exposed metal. Where conductive mounting bolts/screws do protrude through the meter panel and can be contacted from the front of the panel (i.e. not IP2X) and can come into contact with wiring at the rear of the panel then a non-conducting bolt/screw (e.g. nylon or plastic) *shall* be used.

Note: Metal screws with needle points and self-drilling tips are not permitted. The practice of insulating of metal screws using silicone or other material is not permitted.

3.4 Metering Surrounds and Enclosures

3.4.1 General

Meter Surrounds and *Enclosures shall* be constructed:

- to accommodate a meter panel in accordance with these Requirements;
- to prevent the spread of fire in accordance with the requirements of AS/NZS 3000 Wiring Rules in relation to the construction of *Switchboard* cases and surrounds;
- to prevent *direct contact* by persons with wiring at the rear of the meter panel when the meter panel is in the closed position;
- to provide a minimum clearance at the back of the meter panel not less than 75mm;
- provided a clearance between the front of the meter panel and the inside of the *enclosure* door of not be less than 175mm;
- to be provided with suitable fixing devices to allow the meter panel to be fixed and sealed in position in accordance with clause 3.2.1 when closed;
- to ensure movement of the meter panel is not obstructed and the device used to retain the hinged meter panel in the closed position is in correct alignment when all necessary equipment is mounted on the meter panel; and
- with an IP rating suitable for the installed environment, and a minimum degree of protection of IP23 for *Enclosures* and IP2X for surrounds, in accordance with AS/NZS 3000 Wiring Rules.

3.4.2 Temperature Rise Considerations

Metering Facilities and *Enclosures shall* be designed to ensure the meter is not at any time subjected to temperatures in excess of its specified operating range conditions as defined by Table 5, of AS 62052.11.

Appropriate air circulation, ventilation, shading or siting of the metering equipment *should* be considered in meeting those operating temperature limits. Where metering is enclosed within the customer's *Switchboard*, a temperature rise limit (above ambient) of 10 Kelvin is to be used for LV CT and HV connected meters, and 25 Kelvin for whole current meters. Temperature rise limits may be determined using actual type testing procedures in accordance with AS/NZS 61439 or assessment by under AS60890-2009.

4 Whole Current Metering

4.1 General requirements

The customer *shall* provide and maintain facilities in accordance with AS/NZS 3000 Wiring Rules, the applicable Acts, Regulations and Codes and these Requirements to accommodate metering and network equipment.

The customer *shall* provide access during normal business hours to the facilities provided for metering equipment to allow the *metering provider* to carry out installation and maintenance activities.

In general, this requires the customer to provide facilities with sufficient space to mount all the required equipment such that each NMI is individually metered and does not require that the Metering Provider interferes with the *Electrical Installations* facilities and wiring to install the metering, other than that required to connect, fix or *repair* the metering equipment.

Metering equipment may include load control services (e.g. switching on electric hot water during off-peak times). Where *Network Devices* are deemed necessary to control electricity consumption these *shall* be supplied, maintained and installed in accordance with the requirements of the distributor.

For *Whole-Current* directly connected *Metering Installations*, all meter and *Network Device active* terminals *shall* be connected directly to the Metering Protective Device / Metering Isolation Link or Service Active/Neutral Link (multi-occupancies).

A single tariff two or three phase supply *shall* be metered with a single polyphase meter.

All metering and control equipment *shall* be back wired and mounted on a hinged panel attached to a metering *enclosure, surround* or a *switchboard* frame in accordance with clause 3 (no fixed panels are allowed).

For multiple tenancy installations, access to sub boards within tenancies may be required for testing purposes and to verify installations are correctly metered.

Where metering or control equipment is no longer required, the Retailer *shall* be contacted to arrange for the Metering Provider to coordinate its removal.

Customer's ancillary equipment such as surge diverters, voltmeters, phase failure relays etc. *shall* be connected on the load side of the revenue metering equipment. Customer owned Current Transformers for energy management are permitted on the line side of revenue metering equipment at multiple tenancy installations.

4.2 Metering Equipment Protection and Isolation

4.2.1 Protection of Whole Current Metering

Whole Current metering equipment used in Australia is required to comply with AS62052.31 which requires that Whole Current metering equipment is protected by a Type 11b fault current limiting (HRC) fusible link manufactured in accordance with AS60269.3.0 and AS 60269.3.1 with maximum nominal current rating of 80 A.

A metering protective device (MPD) *shall* be installed where the upstream service protective device does not meet the protection requirements of AS62052.31 or the meter manufacturers installation requirements.

4.2.2 Discrimination / Selectivity with MPD

Discrimination/selectivity with the 80 amp meter protection device (MPD) is the customers responsibility. If selectivity is a requirement, a 63 amp or less, C curve *Circuit-breaker* or *Fuse* should be used.

Current Transformer metering may also be necessary where the Installation is 100 Amps or less and is supplying Safety Services to AS/NZS 3000 (Special Electrical Installations)

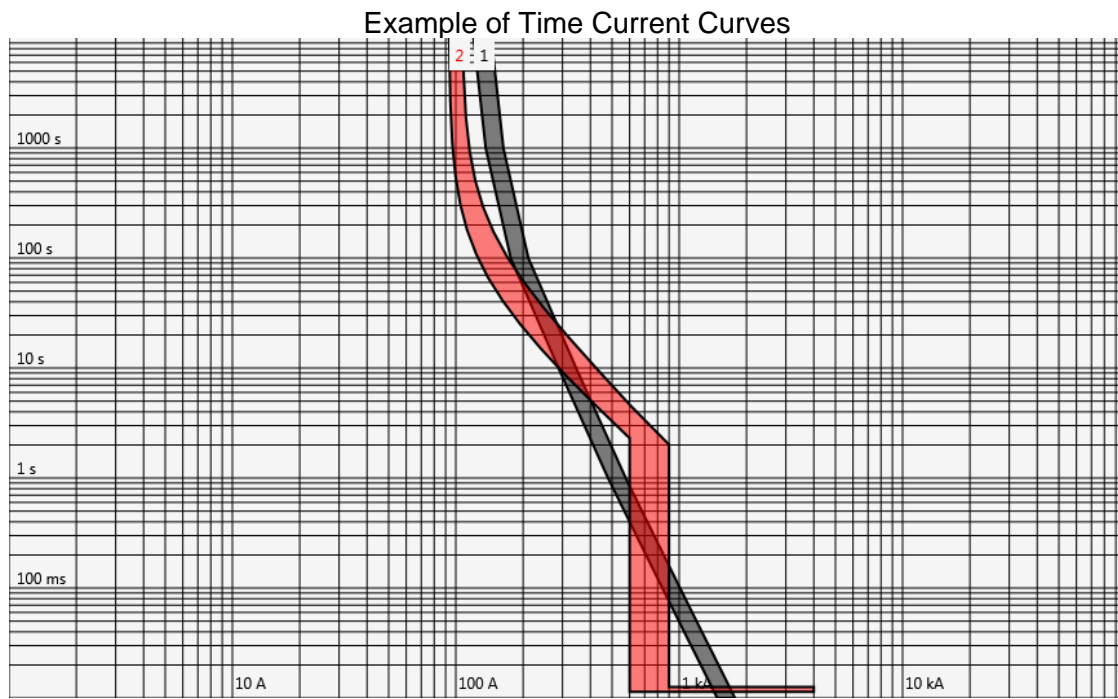

Figure 1 – Time Current Curves (1) MPD 80AGg Fuse (2) De-loading Device C-curve 100A Breaker

4.2.3 Isolation of Whole Current Metering

Whole Current metering equipment *shall* be installed with *accessible* before and after *isolation* such that metering equipment can be installed or replaced safely.

Whole Current metering equipment *shall* be installed on the line side of the individual installation's *main switches*. Each individually metered customer tariff must be able to be individually *isolated* without affecting any other customers supply.

The *isolation* point *shall* be next to (for examples refer to Appendix A – Typical Panel Layouts) the metering equipment and may also be the installations service/metering protective device or an *isolation* link. A switch or *Circuit-breaker* may also be used as an *isolation* point provided the metering equipment is appropriately protected by a HRC *Fuse* in accordance with clause 4.2.1.

All *Isolation* equipment must be able to be sealed in accordance with section 2 of these Requirements.

4.2.4 De-loading of Whole Current Metering

Provision *shall* be made to remove an *Electrical Installations* load from the metering equipment such that the *isolation* fuses or links can be removed under no load. De-loading *shall* be achieved by operating a *Circuit-breaker* or switch on the *load side* of the metering equipment. The de-loading switch or *Circuit-breaker* may also be the installations *main switch* but must be within the same *switchboard* and *adjacent* to the metering equipment and clearly labelled.

4.3 Metering and Control Equipment – Spacing Requirements

4.3.1 General

Meter panels *shall* be of a size to adequately accommodate the metering equipment to be installed upon it and be of an equal or greater size than the meter panels dimensions detailed in these Requirements.

Consideration *should* be given to utilise a larger size meter panel to accommodate:

- extra metering equipment for possible future tariff changes;
- extra Distributor equipment such as service *fuses* and load control equipment;
- additional communication equipment as provided by approved Metering Provider;
- meter *Neutral* and/or *Active* links; and
- meter *Isolation/Protection* devices.

Each *Metering Installation* *shall* have an insulated hinged panel with an area for the exclusive mounting to metering and control equipment that meets the requirements of clause 3 of these Requirements.

The minimum size panel permitted on a single *residential* dwelling *shall* be 480mm (H) x 460mm (W).

4.3.2 Sizes of equipment to be accommodated

The minimum space requirements for mounting of individual meters and control equipment are shown in Table 2 below:

Meter and <i>Network Device</i> Equipment types	Height (mm)	Width (mm)	Depth (mm)
Single Phase Meter	255	150	135
Polyphase Meter	300	185	135
Metering Protection Device / <i>Isolation</i> Link	90	40	90
Distributor Control Equipment	175	110	135
Minimum clearance between metering equipment	10	10	--
Minimum clearance around protection and isolation devices	20	20	--
Minimum distance from edge of panel	20	20	--

Table 2 – Space Requirements for Equipment

4.3.3 Minimum Metering Equipment Combinations

Each *Metering Installation* should make provision for the following minimum equipment combinations.

Installation Type	Minimum metering and network Equipment Types to be accommodated	Typical Minimum Panel Size
<i>Residential House</i>	1 x Polyphase Meter 1 x Single Phase Meter 1 x Distributor Control Equipment 3 x Metering Protection Device / <i>Isolation Link</i> 1 x Main Switch	480mm (H) x 460mm (W)
<i>Residential Duplex</i>	2 x Polyphase Meter 2 x Single Phase Meter 2 x Distributor Control Equipment 7 x Metering Protection Device / <i>Isolation Link</i> 2 x Main Switches	480mm (H) x 550mm (W)
<i>Residential apartment buildings</i>	1 x Polyphase Meter per apartment 3 x MPD / MIL (one per phase) 1 x main switch per meter Refer to clause 4.3.4 for additional space for distributor/network equipment.	Select panel size using building blocks
<i>Commercial buildings</i>	1 x Polyphase Meter 1 x Single Phase Meter 1 x Distributor Control Equipment 4 x Metering Protection Device / <i>Isolation Link</i> 1 x main switch per meter Refer to clause 4.3.4 for additional space for distributor/network equipment.	Select panel size using building blocks

Table 3 – Metering Equipment to be Accommodated

Smaller panels maybe permitted by the Metering Provider in accordance with Clause 1.5 if the customer can demonstrate that the installation is unlikely to be upgraded in the future.

Refer to Appendix A – Typical Panel Layouts for examples of how panels can be laid out to accommodate equipment.

4.3.4 Provision for Distributor Equipment

Each single *residential* dwelling or commercial installation *shall* make space for the installation of one piece of Distributor/Network Equipment.

Where load control is required, multiple *residential* dwellings or commercial installations *shall* leave one in every three meter positions available for the installation of distributor/network equipment. (commonly available load control equipment can typically support the control of up to three independent loads).

Where load control is not required, multiple *residential* dwellings or commercial installations *shall* leave one in every ten meter positions available for the installation of distributor/network equipment.

When distributor equipment is installed in multiple occupancies, it *shall* have a dedicated MPD/MIL such that the distributor equipment can be maintained without interrupting supply to customers.

4.3.5 Equipment dimension and placement examples

Equipment examples are developed from the dimensions of equipment commonly used in the NEM.

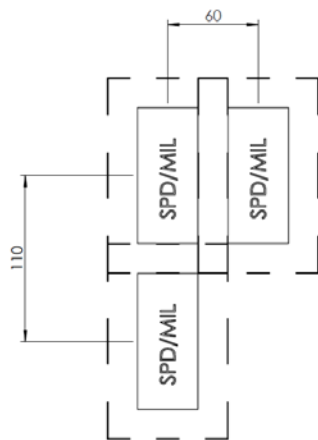
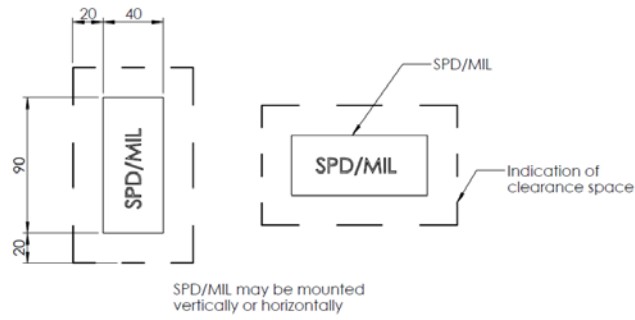

Figure 2 - Meter Protection / Isolation Devices

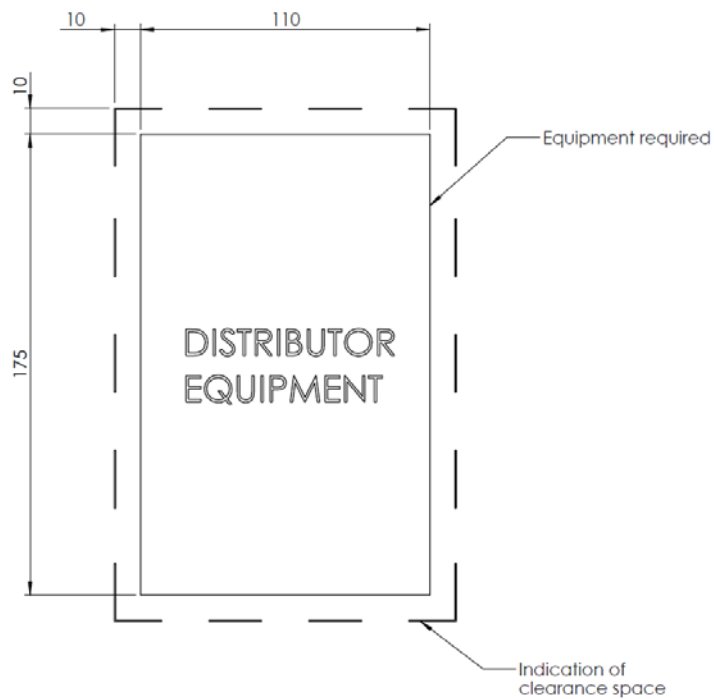

Figure 3 - Distributor/Network Equipment

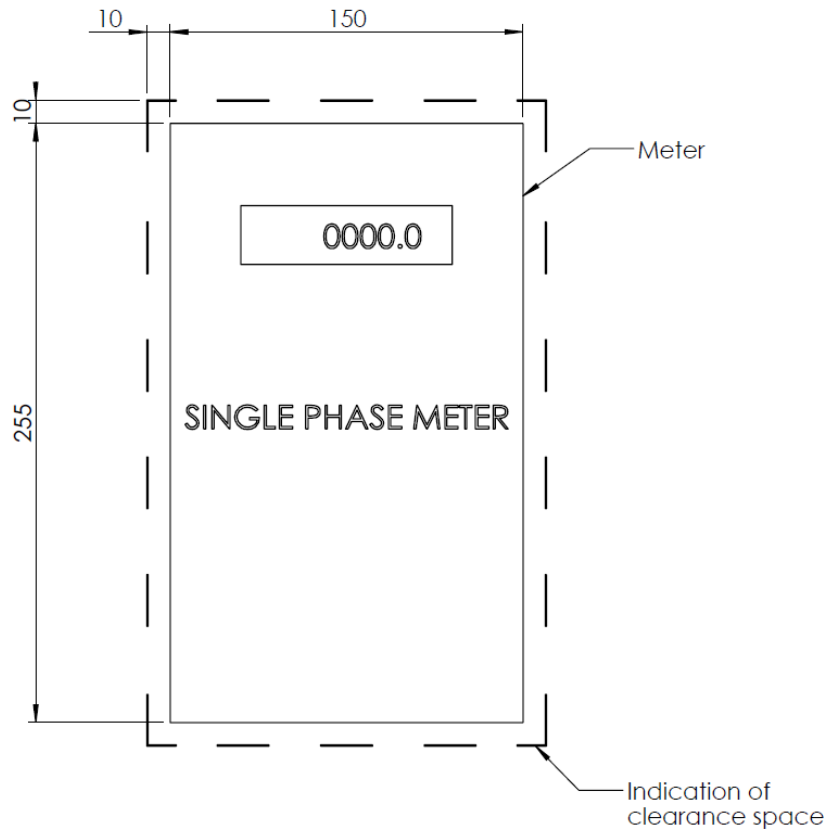

Figure 4 - Single Phase Meter

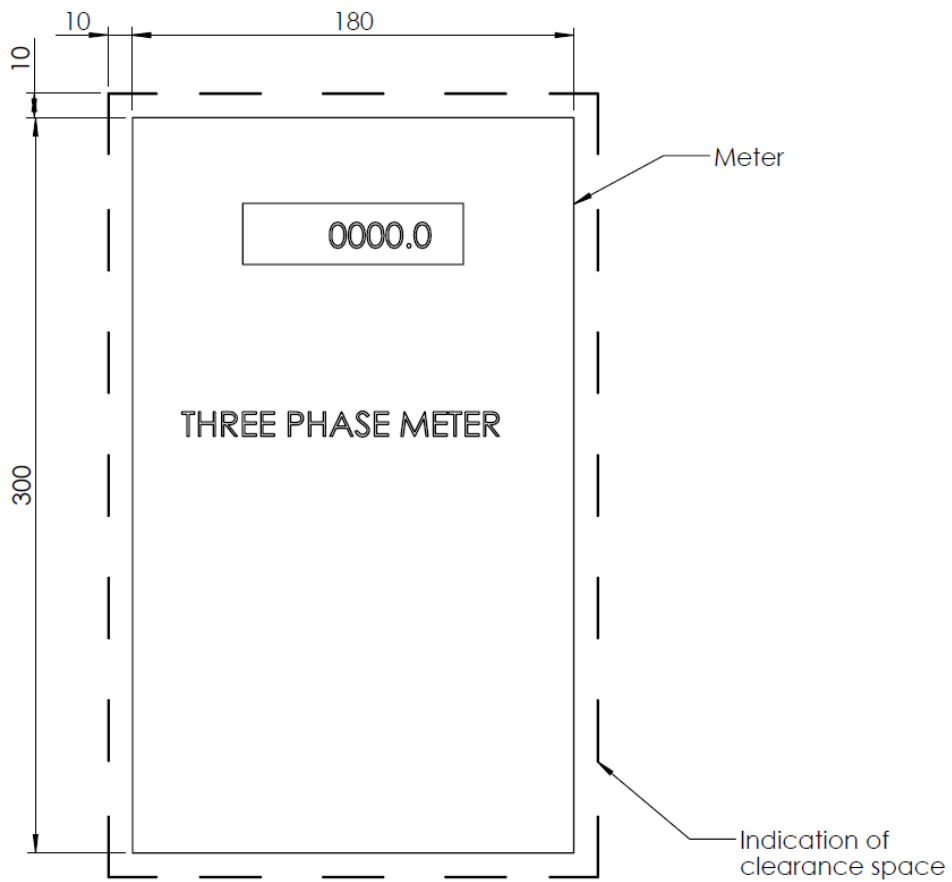

Figure 5 - Three Phase Meter

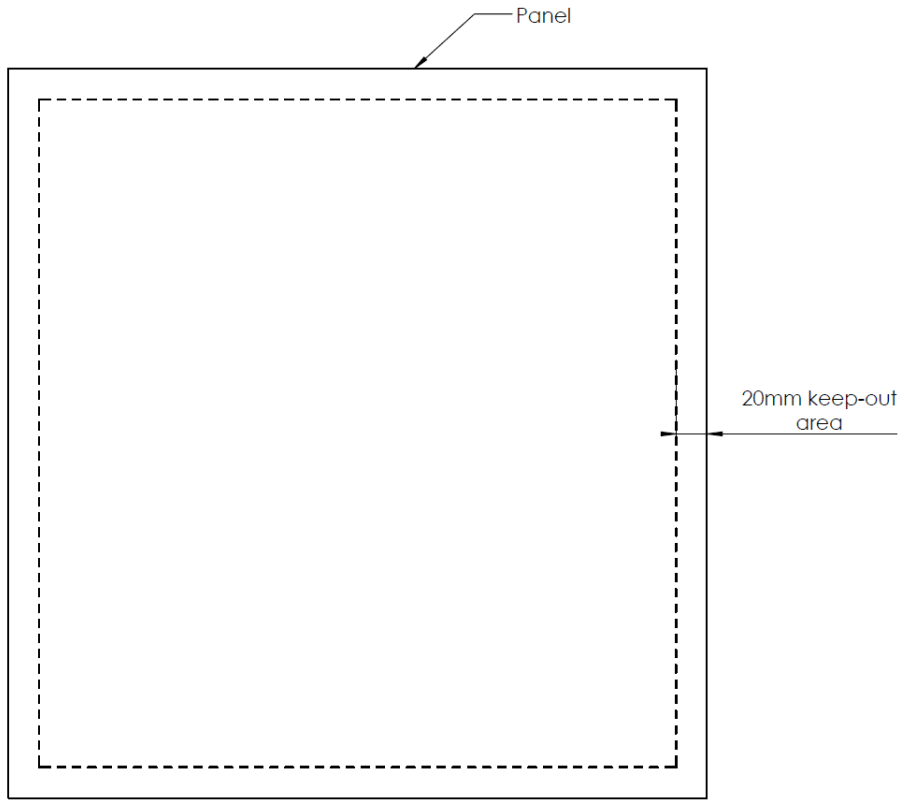

Figure 6 - Minimum Distance from edge of Panel

Equipment building block examples are provided to help *switchboard* manufacturers design boards that can efficiently accommodate the required equipment.

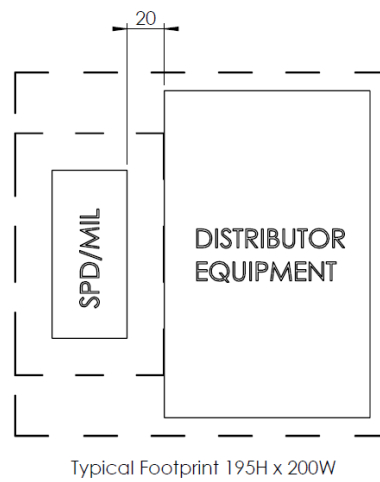
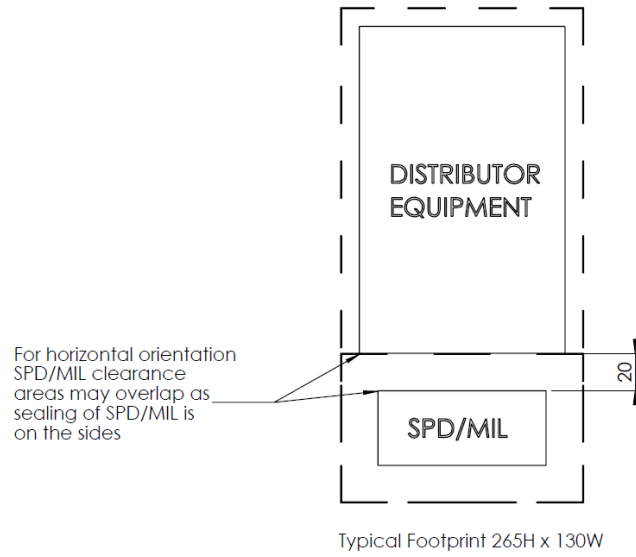
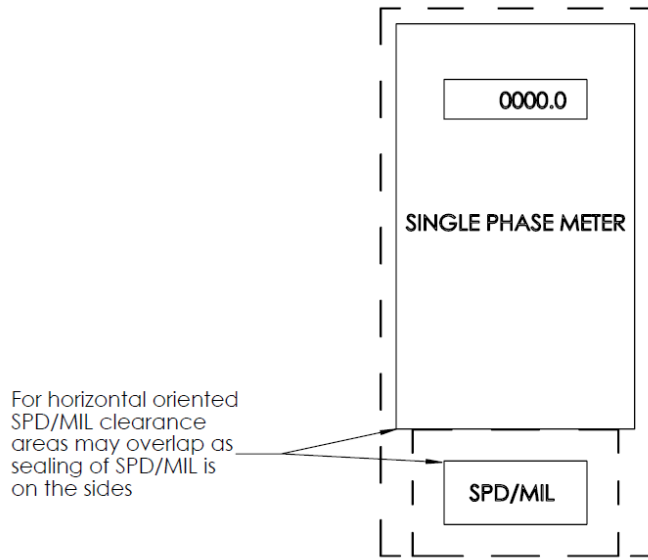
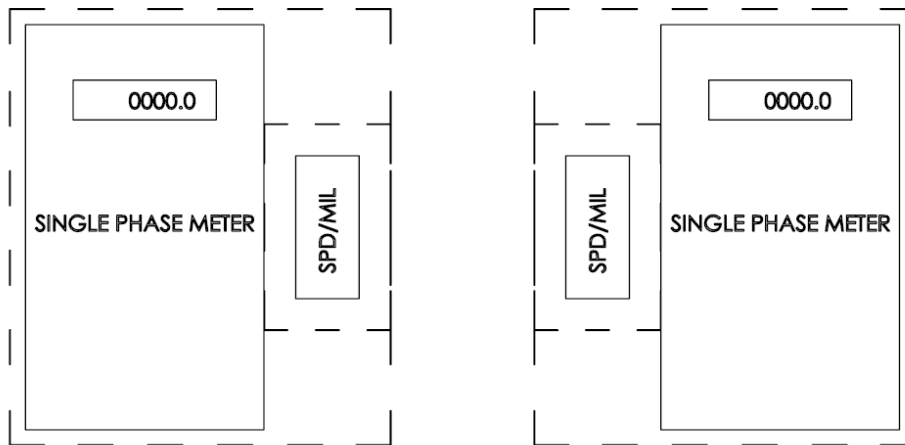

Figure 7 - Distributor Equipment with Isolation link



Typical Footprint 345H x 170W



Typical Footprint 275H x 240W

Figure 8 - Single Phase meter with Isolation Link

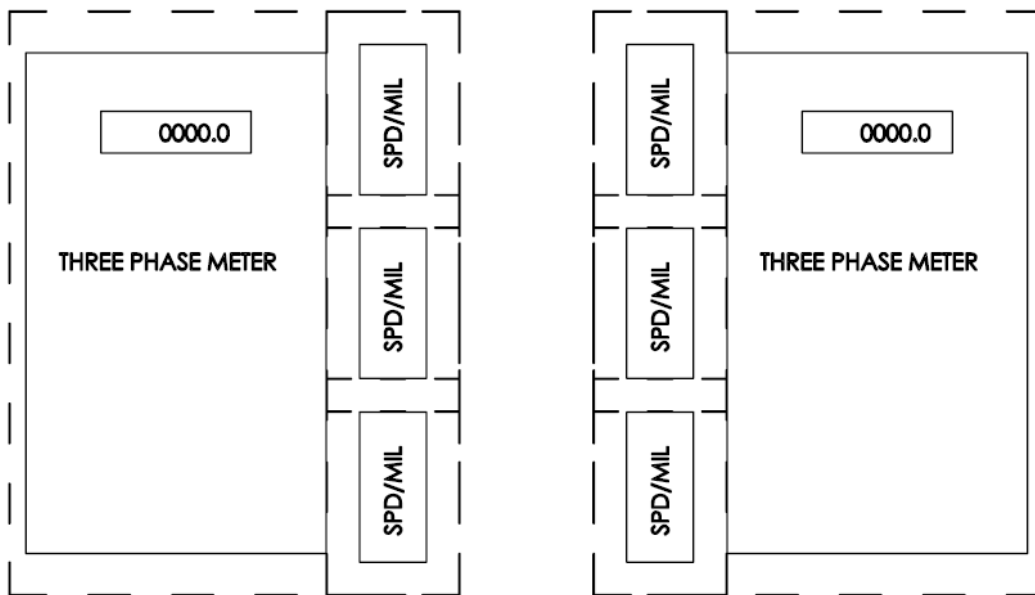
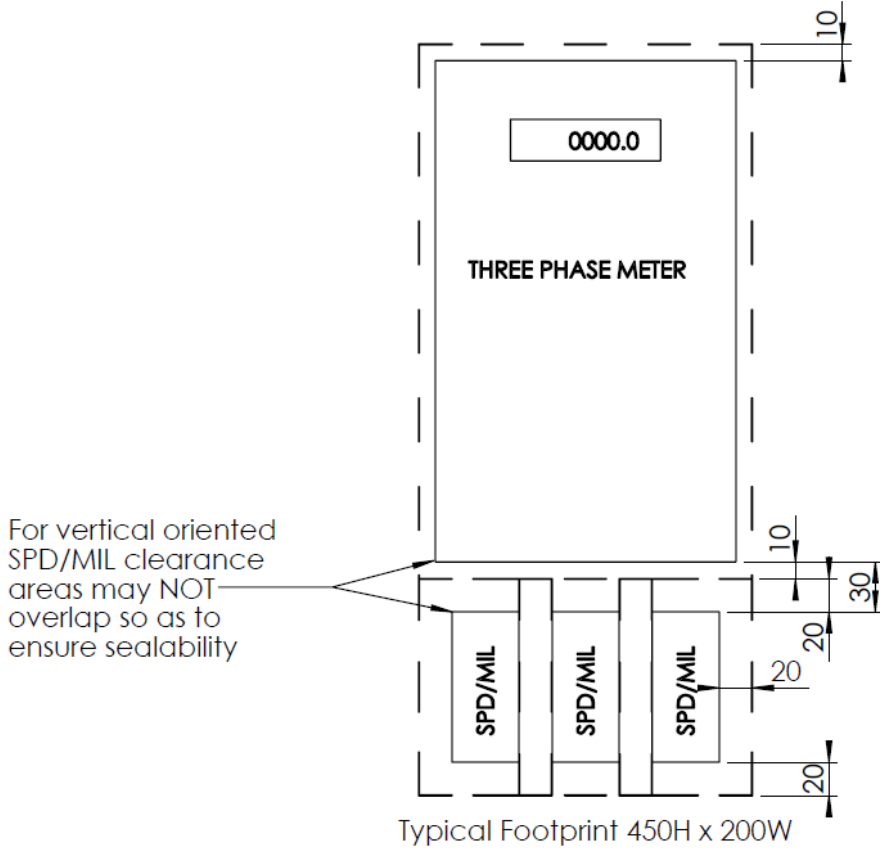

Typical Footprint 350H x 270W

Figure 9 - Three Phase meters with Isolation links

4.4 Whole Current Meter Wiring

Conductors for Whole Current metering *shall* not be less than 4mm² and *shall* not exceed 25mm² with the insulation of *Conductors* coloured in accordance with AS/NZS 3000 Wiring Rules to facilitate identification of *Neutral* and *Active Conductors*.

The metering reference neutral *Conductors* for Whole Current metering *shall* be 4mm².

In all circumstances, the bared *Conductor* for insertion into the meter terminals *shall* be of sufficient length to be clamped under all terminal screws.

Not more than one 16mm² or 25mm² *Active Conductor* may be connected to any single terminal of a Whole Current meter.

For multi occupancies and commercial builds where more than one NMI may be facilitated on a single hinged panel, consideration *shall* be given to limiting the numbers of meters on a panel to reduce the risk of damage to wiring insulation in large looms when the panel is opened and closed.

Compressed (compacted) or hard drawn *conductors shall* not be used as meter wiring due to the flexibility required for the hinged panel and bend radii required connecting to the metering terminals.

Aluminium *cables shall* not be connected directly into meter terminals.

Insulated *Flexible Cables* may be used provided that un-insulated bootlace pins (end sleeves) are securely crimped around the *conductors* using an appropriate tool. A bootlace pin length of at least 25mm is required to ensure clamping under all meter terminal screws.

4.5 Metering Active and Neutral Requirements

4.5.1 Connection of Metering Neutral Conductors to Main Neutral

Integrity and continuity of the *Neutral* of the *Electrical Installation* shall always be maintained at all times. The neutral conductor(s) must be unbroken from the incoming service through to the customer's neutral

The Metering *Neutral* Link (which may be combined with the Service *Neutral* Link dependant on local service rules requirements) *shall* be constructed such that:

- 1) it is connected to the main *Neutral* of the *Electrical Installation* in such a manner that it cannot be disconnected or removed without breaking seals or disturbing the *Neutral* integrity of the *Electrical Installation*; and
- 2) metering equipment *Neutrals* can be disconnected and reconnected without disturbing the integrity of the *Neutral* of the *Electrical Installation*.

Examples of appropriate connection methods include:

- Soldered or crimped to the main *Neutral*; or
- Use of an un-slotted flag lug under the main *Neutral* connection; or
- A sealable terminal or bolt on the *Neutral* link/bar where:
 - the consumer's mains are a busway or busbar arrangement;

- the installation *main Switchboard* is supplied by more than one connection point and a bus-tie arrangement is in place (the consumer's mains *neutrals shall* be connected to a common *Neutral* link/bar); or
- Where the main *Neutral Conductor* is 25 mm² or larger a terminal may be used; or
- Under a stud fitted with a suitable nut that is drilled and tapped into the consumer's mains *Neutral* lug, provided the arrangement can be sealed.

4.5.2 Metering Active and Neutral Links

Metering *Active* and *Neutral* links *shall* –

- (a) incorporate a separate connecting device for the incoming and each outgoing *Circuit*, and
- (b) consist of *Tunnel-type* terminals in accordance with the requirements of AS/NZS 3000.

Where metering *Active* or *Neutral* links are used, they must be sealable or, where this facility does not exist (for larger sized consumer's mains), the links must be installed within a suitable dedicated *enclosure* fitted with a sealable cover.

All *metering* and *Network Device Neutral* terminals *shall* be connected to a dedicated terminal of the metering *Neutral* link via a separate *Neutral Conductor*. Soldered meter and *Network Device Neutral* connections are not permitted.

4.5.3 Metering Active and Neutral Link Mounting

Where metering *Active* and *Neutral* links are mounted on the rear of the meter panel, they *shall* be mounted in such a way that they do not interfere with the mounting of the metering equipment.

Where metering *Active* and *Neutral* links are mounted on the rear of the meter *enclosure* and the material on which they are mounted is conductive, they *shall* be mounted on insulating material with low water absorption properties that will extend past the *live parts* of the link by a minimum of 25mm in all directions. This mounting arrangement is not required where the link has been specifically designed for installation onto metal surfaces.

Access to metering links must not be obstructed by any structure or wiring within the *Switchboard*.

4.5.4 Metering Active and Neutral Link Labelling

Metering *Active* and *Neutral* links *shall* be identified as such.

4.6 Metering requirements for a Builder's Temporary Service (BTS)

Builder's Temporary Services are required to comply with these Requirements.

These requirements include but are not limited to:

- All metering and control equipment *shall* be back-wired and mounted on a hinged panel attached to a metering *enclosure*.
- A metering *Isolation* link per phase *shall* be connected to the line side of the metering.

Builder's Temporary Services meter panels do not need to be dedicated to revenue metering equipment

unless they are intended to be installed in the permanent position.

Attention is drawn to the requirement to also comply with AS/NZS3012 *Electrical Installations - Construction and demolition sites*

4.7 Plug-in Metering

Plug-in kilowatt hour meters are discouraged and only optionally available on existing installations where existing socket bases are already installed and cannot be removed without significant switchboard modification or without affecting adjacent customers. Plug in metering may not be supported at all by some Metering Providers which may require the replacement of the plug-in base and/or the metering panel such that bottom connect metering equipment can be installed on a panel that complies with these Requirements.

4.8 Metering Communications

4.8.1 General

All metering equipment installed in the NEM is required to have communications fitted for remote access and reading. Generally, communications for metering is provided via mobile telephone infrastructure.

When metering *enclosures* are being positioned within or on a building, consideration *shall* be given to ensuring mobile phone signal is available at the metering equipment. Where equipment is installed in a secure location indoors, the use of metering surrounds is encouraged such that mobile phone signal is not impeded by metal *enclosures* and doors.

When metering equipment is enclosed in metal *enclosures*, provision *shall* be made for the installation of an external antenna. Where equipment is installed in switch rooms, this may include provision of conduits to allow for antenna's to be run outside the room to obtain signal.

4.8.2 Segregation of wiring

Antenna or communications cabling associated with metering equipment is generally considered to be operating at extra-low *Voltage*. AS/NZS 3000 Wiring Rules requires that *cables* of low *voltage circuits* and *cables* of extra-low *voltage circuits shall* only be enclosed in the same wiring system where one of the following arrangements is employed:

- (a) The low *voltage cables* are of a type providing the equivalent of double insulation.
- (b) All *cables* or each *conductor* of a multi-core *cable* are *insulated* for the highest *voltage* present.
- (c) The low *voltage cables* are installed in a separate compartment of a common *cable trunking* system having fixed and continuous barriers between compartments.

Antenna or Communications cabling *shall* be installed and fixed, loomed and or cable tied in a manner that it will not obstruct any other *electrical equipment* (*Switchboard* escutcheons and meter panels) and their operational requirements and run in a manner to maximise separation with low *voltage circuits*.

4.8.3 Location of Equipment

With the exception of antennae, metering communications equipment *shall* be located on the meter panel of the associated meter, such that it will not obstruct any other *electrical equipment*, including the

<https://competitivemetering.com.au/>

meter, MIL / SPD, *Neutral* link and *shall* allow unhindered opening of the meter panel, and or *enclosure* door, removal of door where applicable, and removal of the meter panel.

4.8.4 Customer and third party provided Communication Equipment

Customer and third-party provided communication equipment *shall* not be installed on the meter panel or obstruct access to the meter panel. The installed equipment *shall* not obstruct or cause interference to other equipment, including the meter, MIL / SPD, *Neutral* link and metering communications equipment.

Where mobile reception at the metering equipment is improved using a mobile repeater, this equipment *shall* be installed in accordance with this clause and such that it cannot be inadvertently disabled.

5 Low Voltage Current Transformer Metering

5.1 General Requirements

These requirements specify the acceptable arrangements for low voltage current transformer metering (230/400V) with a maximum current specified in clause 1.10 of these Requirements.

In conjunction with this, low voltage current transformer metering installations should also be constructed in accordance with the full requirements of the relevant jurisdictions Service & Installation Rules and NZS /AS 3000 Wiring Rules.

5.2 Isolation

Isolation is required on both sides of individual Current transformers to facilitate de-energisation during testing and/or replacement and to prevent back energisation from any backup supplies that may be present in the *electrical installation*. Only one of the isolation devices is required to provide fault protection for the electrical installation.

Each individual Current Transformer *Metering Installation shall* be capable of being *isolated* separately by a suitable isolator. All *Isolation* equipment *shall* be clearly identified and readily *Accessible* and *shall* be installed and maintained by the customer and be capable of being operated by the Metering Provider and locked in the off position.

5.3 Typical Current Transformer Dimensions

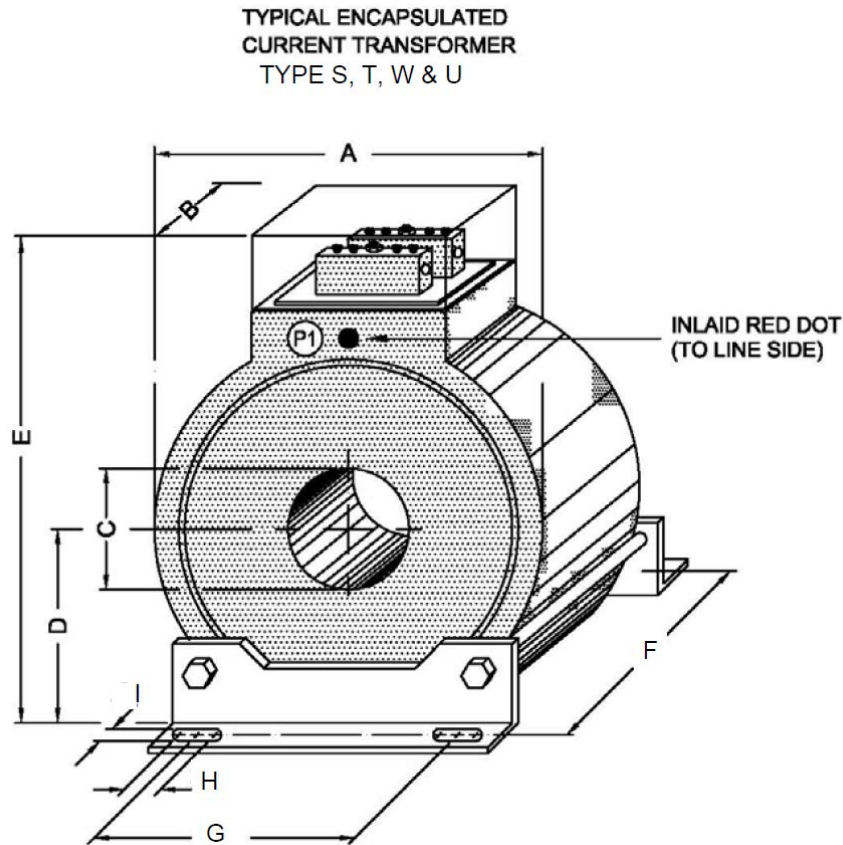

Typical Current Transformer Dimensions (Measurements in Millimetres)									
CT Type	Width	Thickness	Aperture Diameter	Aperture Centre Height	Height	Mounting height	Mounting width	Mounting slot size	Mounting hole size
	A	B	C	D	E	F	G	H	I
S	130	70	45	85	180	80	75	25	10
T	165	65	80	85	210	80	75	25	10
W	170	65	112	85	220	80	75	25	10
U	248	57	170	134	311	123	190	25	10

Table 4 - Typical Current Transformer Maximum Dimensions

5.4 Current Transformer Chambers

Metering current transformers (CTs), potential fuses and their associated wiring shall be mounted in a dedicated chamber within a switchboard enclosure. In general, each current transformer chamber is a dedicated chamber for one NMI and as such, no other equipment or wiring is permitted in or to pass through the chamber. MEN connection, busbars, wiring or equipment other than that required for metering purposes shall not be located within a CT chamber. Exceptions include neutral and earthing conductors with all other exceptions only by agreement with Metering Provider.

Access to the CT chamber *shall* be:

- Available without the need to interrupt supply to a customer.
- Via doors/escutcheon that are easily able to be safely opened and are preferably via doors hinged on a vertical side, with a handle or lock on the opposite side or
- Escutcheons or covers with at least two handles that are easily and safely removed.

- Such access covers or doors shall incorporate a means to be sealed and/or be locked with a minimum 5.5 mm diameter hasp. (Refer to clause 2 of these requirements)
- If hinged, doors/escutcheons *shall* be capable of opening to 90 degrees or be removable.
- Labelled "Revenue Metering Current Transformers".

All live conductors within current transformer chambers *shall* be individually insulated to prevent inadvertent contact with live parts. Neutral conductors are exempt whether considered live or not.

All busbar or cable connection bolting points which cannot otherwise be effectively covered with insulation *shall* be covered with non-adhesive insulation secured in place with cable ties.

Note: CT Chambers are accessed periodically while live by metering providers for maintenance and testing activities. The provision of insulation on busbars and connections is to reduce the risk of inadvertent contact when carrying out testing within the live chamber.

The current transformer secondary terminals *shall* be readily accessible.

It is recommended that Current transformers and busbars be mounted vertically.

Potential fuses *shall* be located forward of the CT secondary terminals and shall not obstruct the clear opening dimensions detailed below. (Refer to Section 5.6.1)

Current Transformer chambers *shall* be constructed in accordance with AS/NZS 61439 to accommodate the Current Transformers of the dimensions detailed in Table 4.

Busbars or cables *shall* be evenly spaced to facilitate current transformer removal and replacement.

The overall dimensions of the Current Transformer chamber *shall* allow adequate clearances to safely and conveniently apply a tong ammeter or flexible Rogowski coil sensor around the primary conductor for testing.

The clear opening through which access to the CT's is obtained *shall* not be less than:

- 560mm H/W x 340mm H/W with a depth not less than 300mm for in-line mounting and
- 440mm H/W x 540mm H/W with a depth not less than 300mm for staggered mounting

The CT Chamber general dimensions *shall* be:

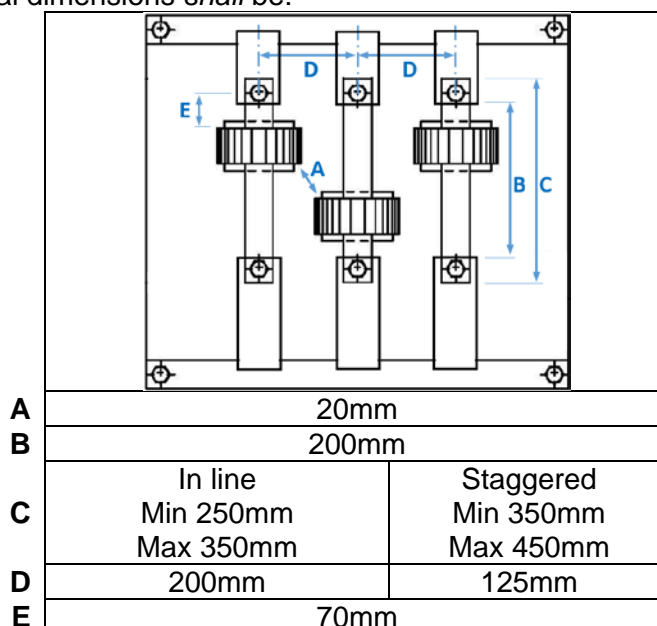

Figure 10 - CT Chamber general dimensions

5.5 Current Transformer Installation Requirements

For general dimensions and mounting of current transformers for correct polarity refer to section 5.3 of these Requirements.

Current transformers *shall* be installed in a manner that facilitates replacement and mounted with suitably sized bolts, nuts and washers (self-tapping screws are not permitted). A readily removable section of busbar as shown in Figure 25 - Typical CT chamber arrangements shall be provided within the current transformer chamber.

Current transformers must have adequate clearance between the outside of the primary conductor and inside of CT aperture (20-30mm gap) to allow for a small conductor of approximately 4mm² to be easily passed through the aperture for the connection of testing equipment.

Current transformers *shall* be mounted such that their nameplates are readily visible.

The current transformer secondary terminals *shall* be *readily accessible* and between 500mm and 1800mm from floor or ground level to allow access to terminals without undue risk to personnel when the switchboard is energised.

5.6 Voltage Circuit Protection & Isolation

Provision *shall* be made for voltage circuit protection and isolation, by way of fuse links, to be installed within the current transformer chamber.

5.6.1 Fuses in Current Transformer Chambers

Fuses installed within the current transformer chamber *shall* comply with AS/NZS 60269, be HRC with a maximum rating of 20 amps and *shall* be mounted in such a manner that the fuse carriers can be removed and replaced without undue risk to personnel when the switchboard is energised (facing the front of the chamber and in front of the plane of the primary conductors). (Refer to Figure 25 - Typical CT chamber arrangements).

Where the neutral conductor of the voltage circuit terminates inside the chamber, it shall be terminated with the same fuse carrier type as the phase conductors, coloured white and containing a link rather than a fuse link

The voltage circuit fuses *shall* be connected to the busbars in such a manner that the energising current of the meter will not be registered through the current transformers (i.e. should be connected to line side of the current transformers).

Particular care *shall* be taken with unprotected supply conductors between the busbar and voltage circuit fuses. The supply conductors from the busbars to the voltage circuit fuses *shall*:

- Be as short as practicable,
- Be double insulated and a minimum of 4mm² stranded cable of not more than 7 strands.
- Not have any joints in the conductors
- Originate from within the current transformer chamber
- Be adequately supported,
- Not exceed 1 metre in length,
- Be adequately separated from busbars or conductors operating at higher temperatures (12mm is considered adequate separation).

Where colour coded cables are unavailable, colour coding *shall* be provided by the use of appropriate coloured sleeving at both ends with a minimum sleeve length of 150mm.

5.6.2 Fuses on Meter Panels

Where metering panels are remote to Current Transformer Chambers, the installation of an additional set of fuses on the metering panel may be appropriate.

Should fuses be installed on the meter panel they *shall* comply with AS/NZS 60269, be HRC with a rating of 6 amps and *shall* be mounted in such a manner that the fuse carriers can be effectively sealed, removed and replaced without undue risk to personnel.

Fuses should be mounted on the front of the meter panel beside the test block.

Appendix B – Low Voltage CT Layouts, Figure 24 - General arrangement for metering fuse sealing blocks provides an example of an effective sealing method for voltage circuit fuses mounted on the meter panel.

Refer to Appendix B – Low Voltage CT Layouts, Figure 23 – Typical CT Meter Panel Equipment Placement for examples of how fuses may be installed on the meter panel.

5.7 Current Transformer Metering Panels

Each current transformer *Metering Installation shall* have an insulated hinged panel with an area for the exclusive mounting to metering and control equipment that meets the requirements of Clause 3 of these Requirements.

The minimum size panel permitted *shall* be 550mm (H) x 550mm (W).

The clearance from the back of the meter panel to the back of the enclosure shall be a minimum of 75mm.

Where meters are enclosed, the clearance between the front of the meter panel and the back of the closed door (including any hat section) shall be not less than 175mm.

Whole Current metering *shall not* be installed behind or on the same panel as current transformer metering except where the Whole Current meter is for a secondary supply meter associated with the same customer (i.e. for the same NMI).

All current transformer Meter Panels *shall* have provision for sealing in accordance with section 2 of these Requirements.

Refer to Figure 23 – Typical CT Meter Panel Equipment Placement for examples of how equipment may be placed on the meter panel.

5.8 Spacing between Meters and Heavy Current Carrying Conductors

AS62052.21 and 22 provides limits for the maximum AC magnetic field that metering equipment can be exposed to from nearby heavy current carrying conductors without causing errors in meters registration. To ensure maximum accuracy of the metering installation it is necessary to take adequate precautions against the effects of external magnetic fields.

5.8.1 Grouped Conductors

There are no special requirements for spacing or shielding where the current is carried by a three-phase cable or three single core cables in a trefoil formation.

5.8.2 Separated Conductors

Where conductors of a circuit are physically separated, as in spaced single core cables or busbars, meters/meter must be suitably spaced from the conductors to reduce the effect of the magnetic field.

Exception: A distance not exceeding two metres at each end to facilitate termination of the cables is permitted

Where spacing alone cannot be achieved, magnetic shielding of suitable thickness may be used to reduce the minimum clearance by enclosing the conductors in a mild steel pipe or duct or enclosing the meters/meter wiring within a mild steel enclosure. Stainless steel, some alloy steels, aluminium, copper and other non-ferrous metals are not suitable materials for magnetic shielding. When enclosing *metering equipment*, consideration should be given to signal propagation for communications equipment associated with the meters (Refer to section 4.8)

The minimum spacing between revenue meters/meter wiring and conductors carrying heavy currents shall be derived from Table 5 - intermediate points may be obtained by interpolation.

Conductor Current (A)	Min Spacing (mm)			
	No Shielding	Thickness of Shielding (mm)		
		1.2	2.5	5.0
Up to 150	100	-	-	-
400	500	375	250	125
600	700	525	350	175
1000	900	675	450	225
1500	1200	900	600	300
2000	1400	1050	700	350
3000	1700	1275	850	425
4000	2000	1500	1000	500

Table 5 - Spacing between revenue meters/meter wiring and conductors carrying heavy currents

Note: Where the above spacing cannot be maintained within the switchboard, it is expected that the meter panel be installed remote from the switchboard. Particular care should be taken when the switchboard is constructed of aluminium or stainless steel.

Under no circumstances shall current transformer meter wiring be grouped with other conductors. Meter wiring run externally to the switchboard enclosure shall be contained within a separate conduit or cable trunking.

Each individual set of current transformer meter wiring installed behind a meter panel containing multiple groups of current transformer meters, shall be grouped and separated from the other sets of current transformer meter wiring.

5.9 Current Transformer Metering Test Block

A test block that complies with **Error! Reference source not found.** (Mk III) of Appendix C – Specification for Test Blocks for Transformer-Operated Meters of these Requirements *shall* be incorporated in all *metering installations* with current transformer metering.

The test block shall be mounted immediately below, and in the same plane as the current transformer meter, such that the voltage connection terminals are on the right-hand side when viewed from the front of the test block.

The test block shall be so mounted that the CT secondary links fall closed and the voltage circuit links fall open.

Refer to Figure 23– Typical CT Meter Panel Equipment Placement for examples of how test blocks are expected to be placed on the meter panel.

All connecting wiring shall be enclosed under the test block cover (surface wiring is not permitted).

5.10 Wiring to Current Transformers, Test Blocks etc.

Current transformer metering installations *shall* be wired in accordance with Figure 26 - Wiring Diagram for CT Metering in Appendix B – Low Voltage CT Layouts. Cables shall be unbroken (without joints) and individually and suitably identifiable (numbers, colours) along the entire length from CT chamber to metering panel in accordance with Figure 26.

Current Transformer wiring within the CT chamber *shall* be double insulated if the micro ambient is more than 55 degrees.

Where maximum route lengths permit, an 11 core 2.5mm² multicore cable with numbered cores and earth, identifiable along the entire length is recommended between the current transformer chamber and meter panel.

The conductors in the cores *shall* be PVC insulated stranded cable of no more than 7 strands. Where numbered cores are used, the following convention shall be implemented.

Core Number	Designation
1	A Phase CT Polarity
2	A Phase CT Return
3	B Phase CT Polarity
4	B Phase CT Return
5	C Phase CT Polarity
6	C Phase CT Return
7	A Phase Voltage Circuit
8	B Phase Voltage Circuit
9	C Phase Voltage Circuit
10	Neutral
Green/Yellow	Earth

Table 6 – Multi-Core Cable core designations

A maximum route length of a standard wiring loom *shall* be in accordance with Table 7 of these Requirements.

Within a switchboard, provision for the loom *shall* be provided in the form of channels, holes, knockouts or conduit of adequate sizes to install the loom.

Where the meter panel and current transformer chamber are remote from one another, a minimum 32mm conduit *shall* be provided to accommodate a standard loom.

Unless otherwise agreed with the *metering provider*, the conduit *shall* be rigid, and bends shall be used to negotiate comers and their number *shall* be kept to a minimum. The use of elbows is not acceptable.

A draw wire *shall* be provided where the loom is not installed at the time of the conduit's installation.

A fixed neutral terminal comprising of a 6mmⁿ tapped hole with a brass metal thread equipped with a flat and lock washer and nut where required shall be provided for the connection of the metering neutral in each current transformer chamber.

The terminal shall be connected to the neutral associated with the active conductors being metered or the consumer's mains neutral prior to the current transformers.

A meter neutral label *shall* be attached to the meter neutral conductor adjacent to its connection to the main neutral.

Where the neutral conductor does not pass through a connection within the current transformer chamber, the conductor supplying the terminal *shall* be double insulated and a minimum size of 4mm² and terminated at a link.

The tee off connection *shall* be located in an area which is segregated from all other wiring and equipment, labelled "metering neutral", and provided with facilities to seal the area with a seal.

Earthing of metal metering and current transformer enclosures *shall* conform with the requirements of AS/NZS3000, including size of earthing conductor. Where earthing of a separate metering enclosure is required, the earthing conductor may be installed within the conduit containing the loom.

Current transformer metering secondary non-polarities shall be starred and earthed as shown in Figure 26 - Wiring Diagram for CT Metering. The earth conductor shall be connected directly to the main earth conductor or earth bar and not to a separate earthed medium such as the switchboard frame.

The earthing conductor shall be PVC insulated stranded cable of no more than 7 strands and can be 2.5mm² cable for all current transformer metering installations.

Rated Burden	Max Route Length 2.5 mm ²	Max Route Length 4 mm ²	Max Route Length 6 mm ²
5 VA	7.5m	12.5m	18m
15 VA	22.5m	40m	—
Note:			
<ul style="list-style-type: none"> • 200/5 (S) ratio CTs are supplied with a rated burden of 5 VA • 800/5 (T), 1500/5 (W) and 2000/5 (U) ratio CTs are supplied with a rated burden of 15 VA. 			

Table 7 – CT Secondary wiring size requirements

5.11 Changes to Existing Current Transformer Metering Installations

When all or part of the existing metering installation requires changing (e.g. upgrading of a switchboard, change to the type of supply), the metering provider may require the total metering installation, including current transformers, to be upgraded to comply with these Requirements (Refer to Section 1.8) and the National Electricity Rules.

6 High Voltage Metering

This page is intentionally left blank
High Voltage metering requirements to be added in future versions

7 Specific Jurisdictional Requirements and Transitional Arrangements

The requirements for the facilities customers provide for the installation of metering and network equipment have changed significantly as the electrical industry evolved during the 20th century. Energy distribution and hence metering was originally managed by small regional authorities and councils that resulted in a significant variation in the arrangements for metering equipment at customers properties. As smaller energy distribution businesses merged becoming larger businesses during the second half the 20th century, the requirements for metering installations have also been slowly aligning to a point where a mostly consistent set of requirements has existed for each state since the start of the 21st century.

These requirements seek to start the transition to a nationally consistent approach to the specification of requirements for metering installations. This section seeks to provide guidance on how legacy arrangements are to be upgraded in a range of scenario's when the metering equipment is changed.

The section addresses each jurisdiction individually such that key stakeholders such as energy retailers, distributors, governments and regulators for that jurisdiction can contribute to how the various legacy metering arrangements are to be handled when applying these requirements during metering works.

7.1 Queensland

7.1.1 Card Operated Metering

In Ergon Energy's Far North Queensland region, card operated meters (COMs) will be supplied for designated remote communities and most *isolated* generation sites in the Torres Strait Islands.

Commercial installations requiring special tariffs or current transformer metering will not use card operated meters.

Temporary Builder's Supplies in card operated meter areas *shall* have card operated meters installed with commercial tariffs to apply.

Requests for exemptions can be lodged for critical loads (e.g. sewerage pumps, unmanned communications sites etc) so that card operated meters are not used.

A metering *Isolation* link is required to be installed on the line side of all card operated meters.

In general Ergon Energy will provide one service to a community title scheme or cluster development installation with card operated meters.

Where a cluster or community title scheme development with card operated meters consists of a number of tenanted buildings a meter position located on common ground for each building may be permitted.

The following meter positions will also be acceptable:

- i. The *main Switchboard* located on common ground and all metering equipment installed at this position.
- ii. The *main Switchboard* and the first metering point located on common ground and subsequent metering points located either on each building or as otherwise approved by Ergon Energy.

Note: - A single community meter position is preferred, however approval may be granted for an additional community meter where a single position is not practical. Each community meter will be treated as a separate account for billing purposes.

To clarify the required metering type in the remote communities and *isolated* generation sites in Far North Queensland contact Ergon Energy Customer Service.

7.2 New South Wales

This section is intentionally left blank
Specific NSW metering requirements to be added in future versions

7.3 South Australia

This section is intentionally left blank
Specific SA metering requirements to be added in future versions

7.4 Tasmania

7.4.1 Background

Tasmania has had relative state-wide stability around the requirements for metering panels for many years. A key feature of the legacy Tasmanian arrangements was the use of a small fixed meter panel for the exclusive installation of utility meters. A space has also historically been reserved within the meter enclosure beside the panel for consumer wiring to run to avoid the need for a consumer's electrician to access the space behind the meter. The meter panel itself has been historically supplied by TasNetworks until the commencement of metering contestability on December 1st, 2017.

These Requirements introduce new requirements (among others) that all metering panels are to be hinged and also make allowance for consumer wiring to be run behind the hinged panel. This section primarily seeks to clarify the scenarios around when legacy meter panels/enclosures in Tasmania are upgraded to either fully or partially meet these requirements.

These requirements are to be applied in accordance with the [TasNetworks Service and Installation rules](#) and the [Department of Justice Electricity Consumption Metering Safety Requirements \(Tasmania\)](#).

Examples legacy Tasmanian residential switchboards / meter panels



7.4.2 New Installations and consumer-initiated works

New installations, upgrades to consumers mains and relocations of meter positions *shall* fully comply with these requirements from July 1st 2021.

Meter installations triggered by the installation of an Inverter Energy System (IES) as defined by AS 4777 or for tariff changes may be installed on the legacy standard flat panel. If the panel is constructed from material containing Asbestos, timber or is broken, the fixed panel itself *shall* be replaced with a fixed panel made from materials that conforms with these requirements (like for like replacement)

If there is insufficient space for metering and distributor equipment on the legacy fixed panel, the panel *shall* be upgraded to fully comply with these requirements.

7.4.3 Repairs and faults

If the metering enclosure is to be replaced because of damage (e.g. corrosion), then the replacement enclosure and panel shall fully comply with these requirements.

Replacement of faulty metering or distributor equipment may be installed on the legacy standard flat panel. If the panel is constructed from material containing Asbestos, timber or is broken, the fixed panel itself *shall* be replaced with a fixed panel made from materials that conforms with these requirements (like for like replacement).

7.4.4 Metering Protection

The TasNetworks Service and Installation rule require that a 100A HRC service protection device be installed on the network connection. This device exceeds the protection requirements for metering equipment used in Australia and as such, in all instances, a meter protection device that meets these Requirements must be installed (i.e. 80A HRC next to the meter). The downgrading of the Service protection device is not permitted by TasNetworks.

If the installation of the metering protection device cannot be accommodated on the legacy fixed panel, then the panel shall be upgraded to one that meets these requirements.

We would also like to include:

7.4.5 Location of Panels

For all new connections, and meter relocations, restrictions in the TasNetworks SIR's and the DOJ Electricity Consumption Metering Safety Requirements can be relaxed to allow for panels to be mounted 2000cm to the top of the meter Panel and 500cm minimum height to the bottom of the meter panel. Existing metering enclosures box can stay between 180cm & 210cm per the DOJ Electricity Consumption Metering Safety Requirements.

7.5 Australian Capital Territory

This section is intentionally left blank
Specific ACT metering requirements to be added in future versions

7.6 Victoria

This section is intentionally left blank
Specific Vic metering requirements to be added in future versions

Appendix A – Typical Panel Layouts

Single Occupancies

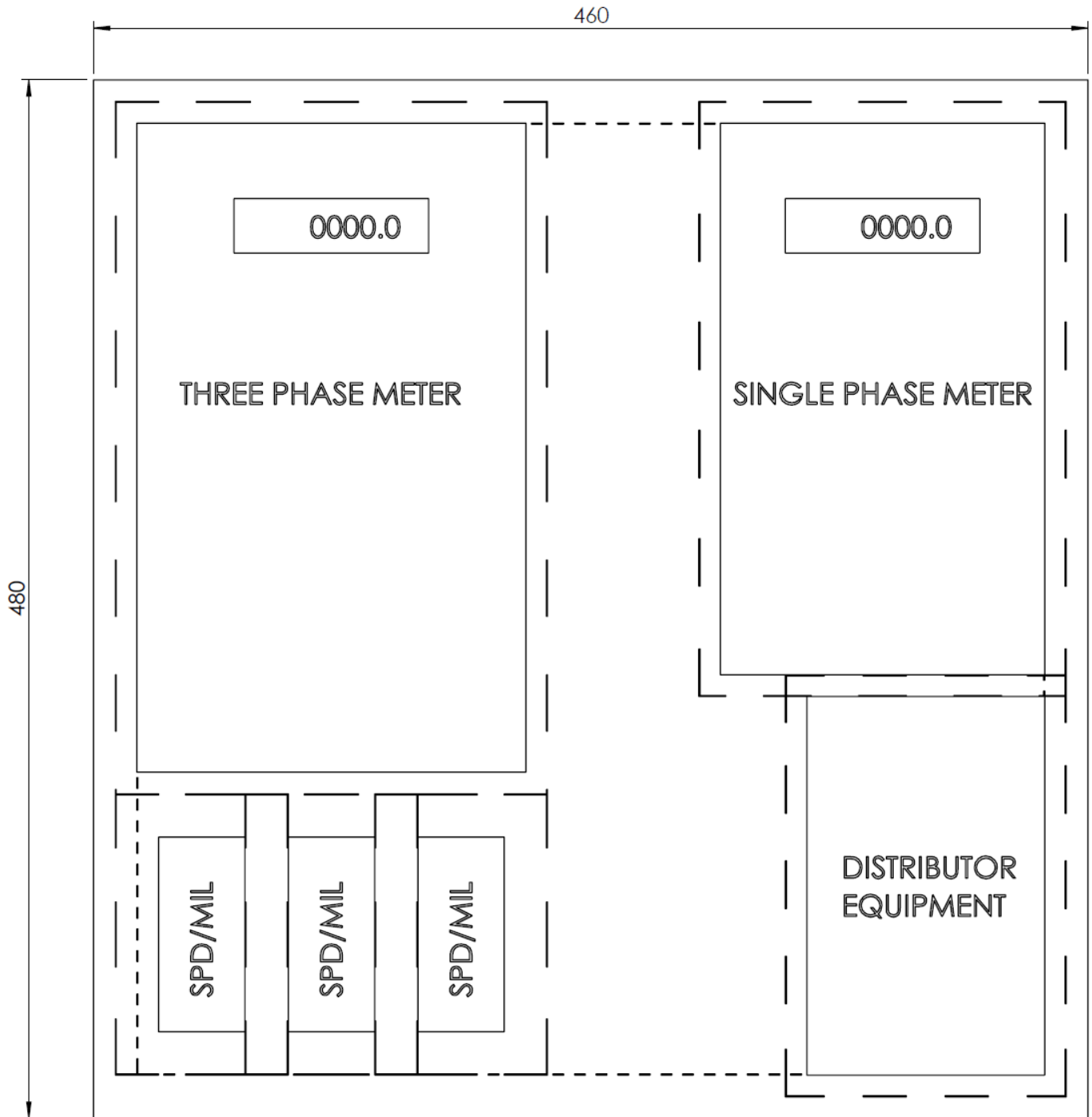

Figure 11 - Typical Panel Layout for Residential House with Multi-phase, single phase meters and load control

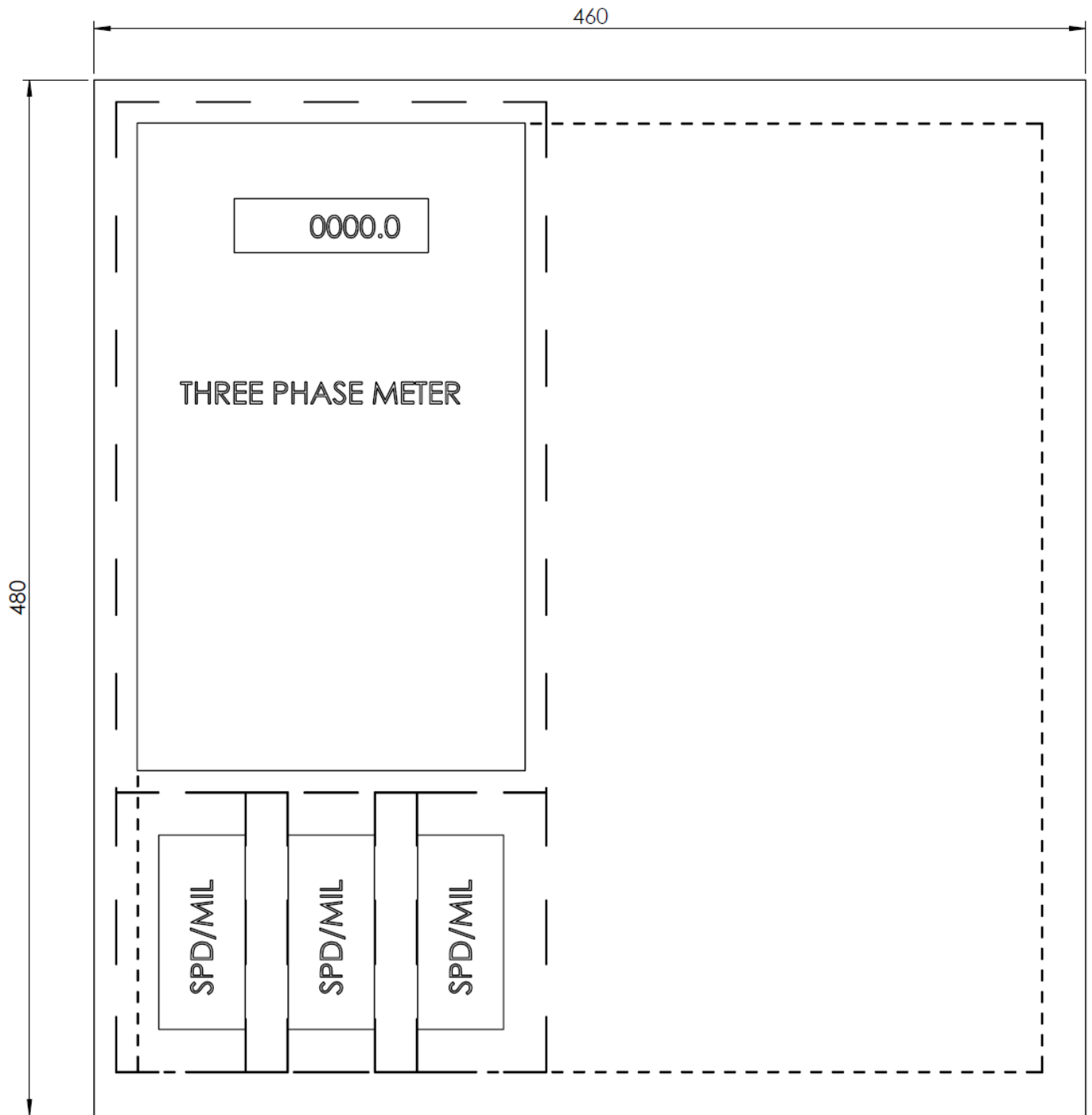

Figure 12 - Typical Panel Layout for Residential House with Multi-phase meter

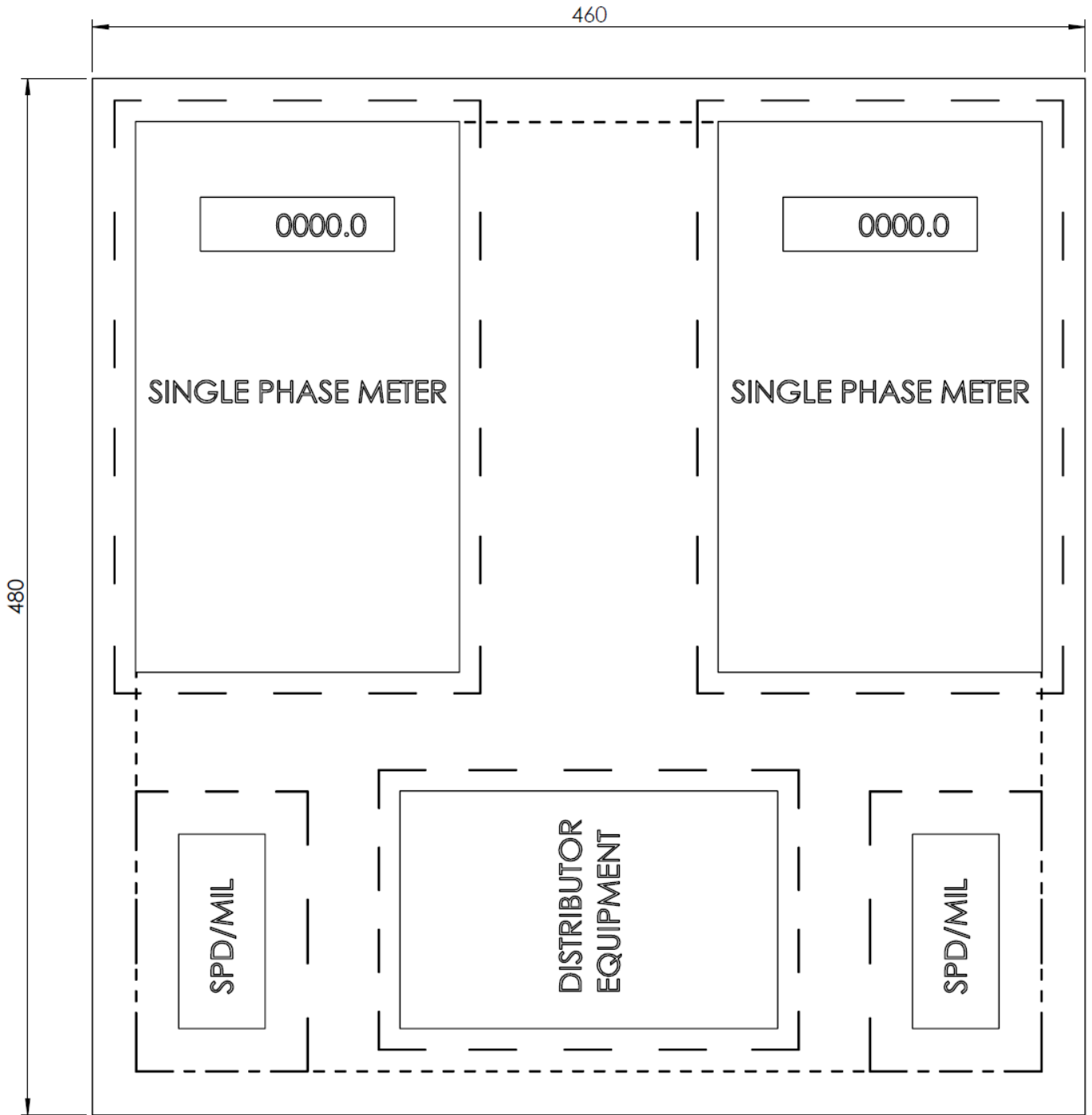

Figure 13 - Typical Panel Layout for Residential House with two single phase meters and load control

Multiple Occupancies

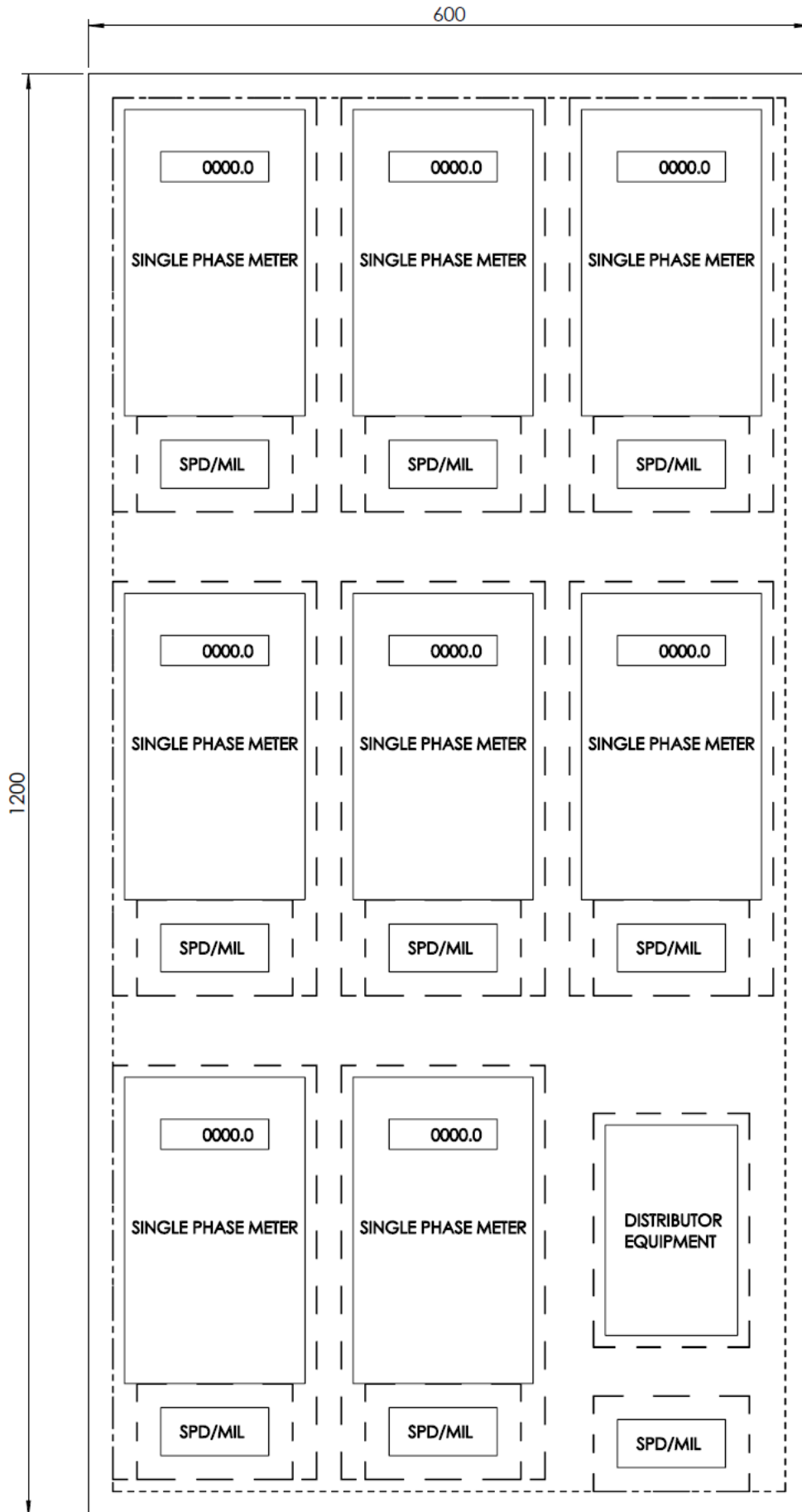

Figure 14 - Typical Panel Layout for Multi Occupancy, Single phase, 1200 x 600 panel



Figure 15 - Typical Panel Layout for Multi Occupancy, multiphase, 1200 x 600 panel

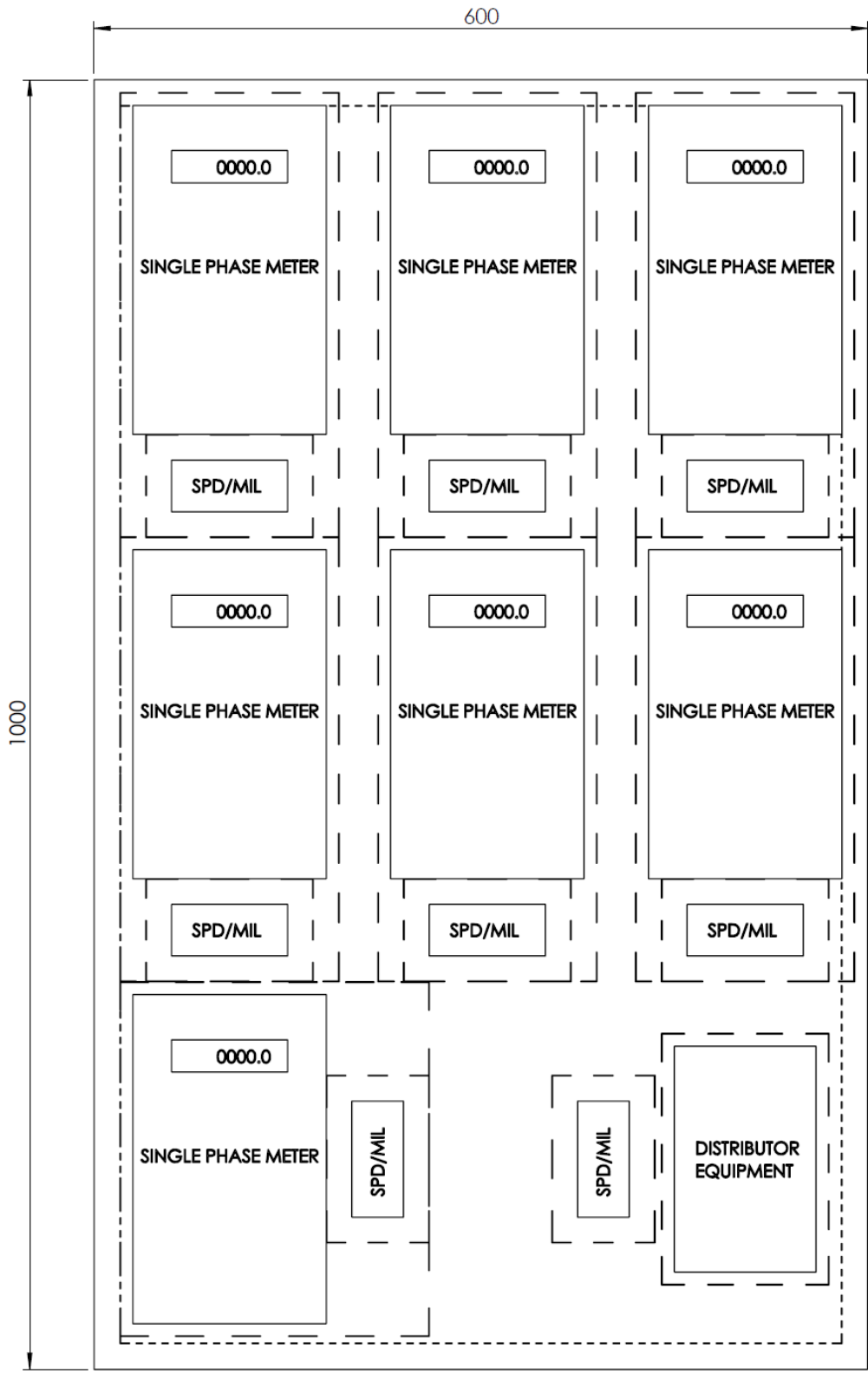

Figure 16 - Typical Panel Layout for Multi Occupancy, Single phase, 1000 x 600 panel

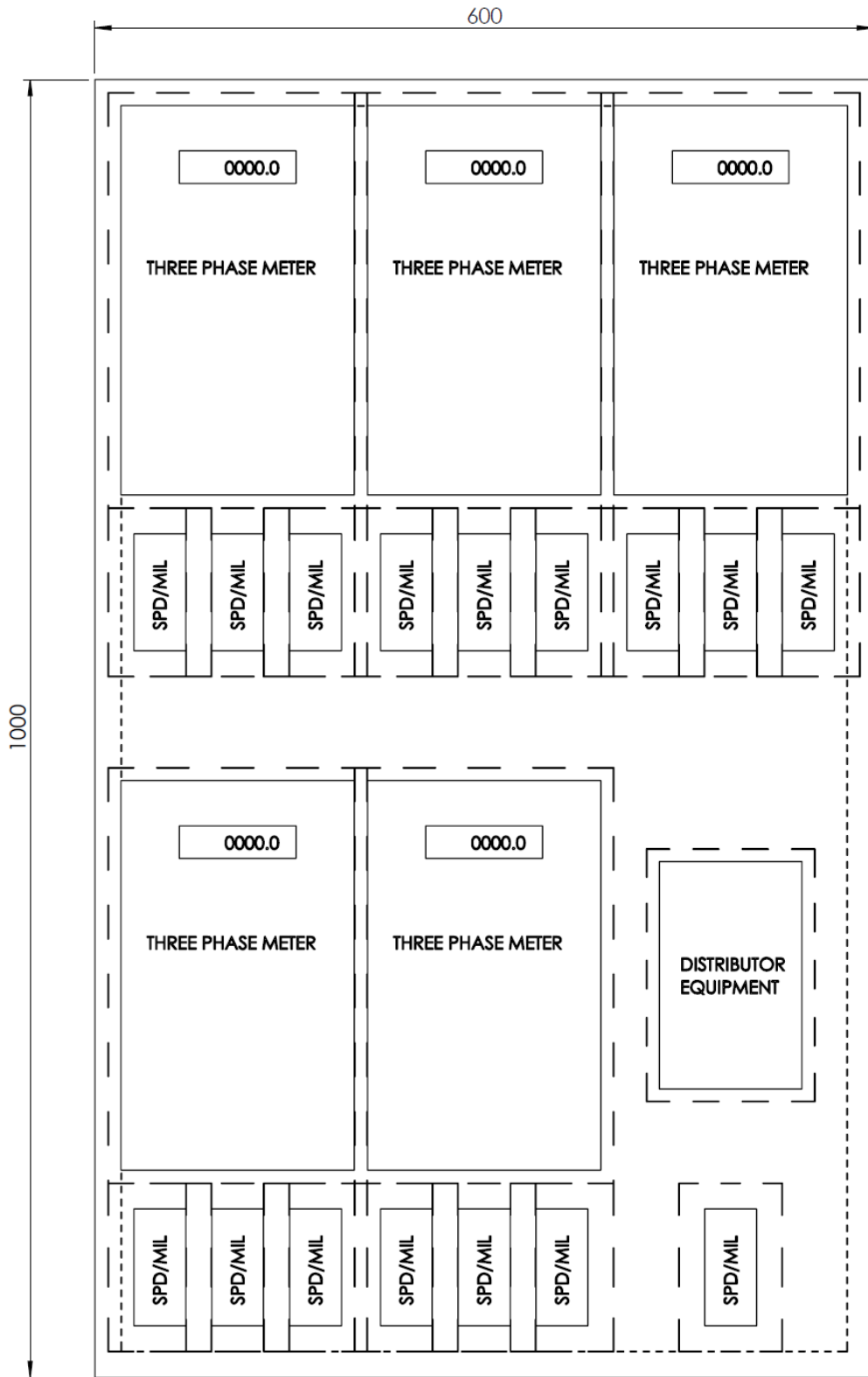

Figure 17 - Typical Panel Layout for Multi Occupancy, multiphase, 1000 x 600 panel

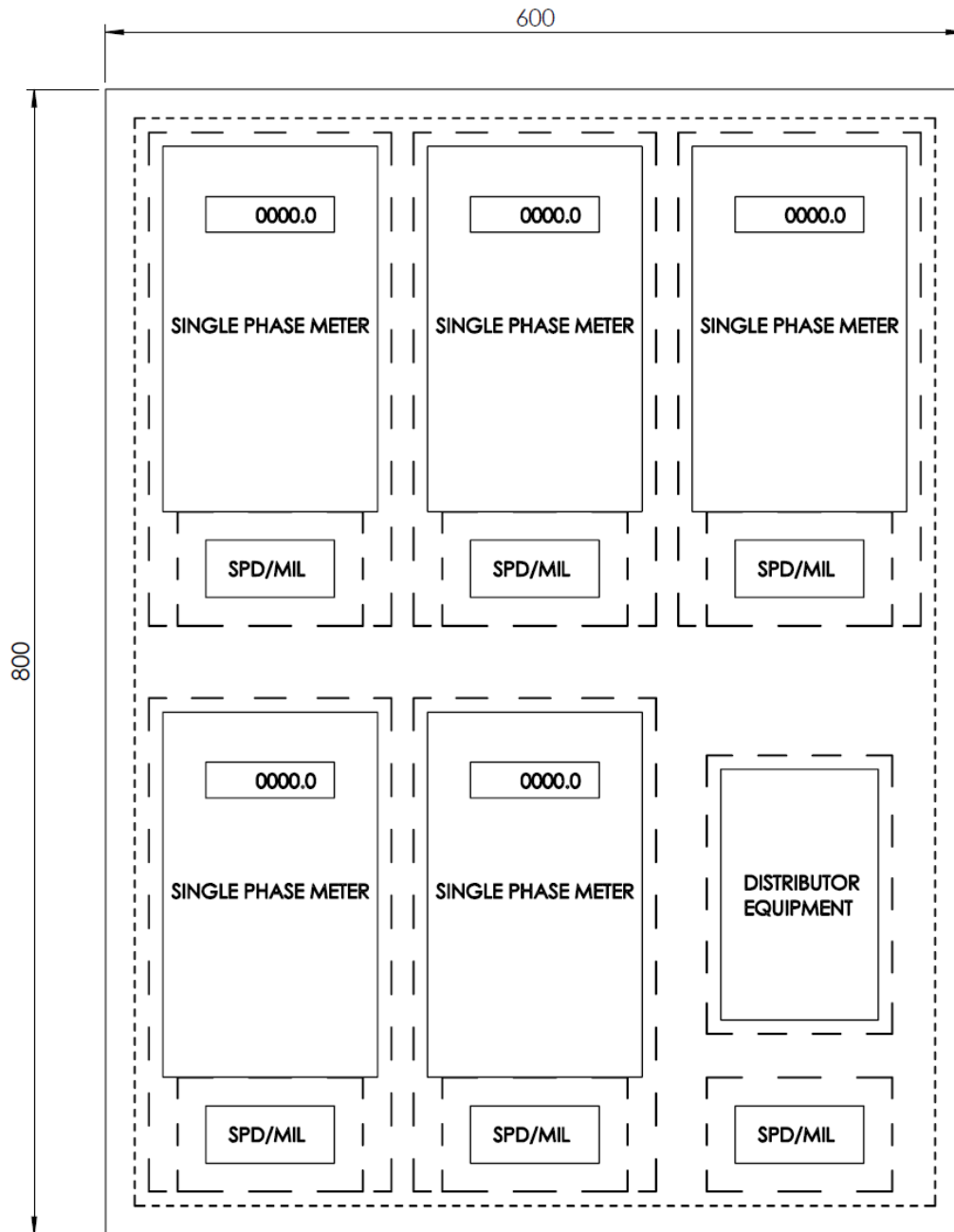

Figure 18 - Typical Panel Layout for Multi Occupancy, Single phase, 800 x 600 panel

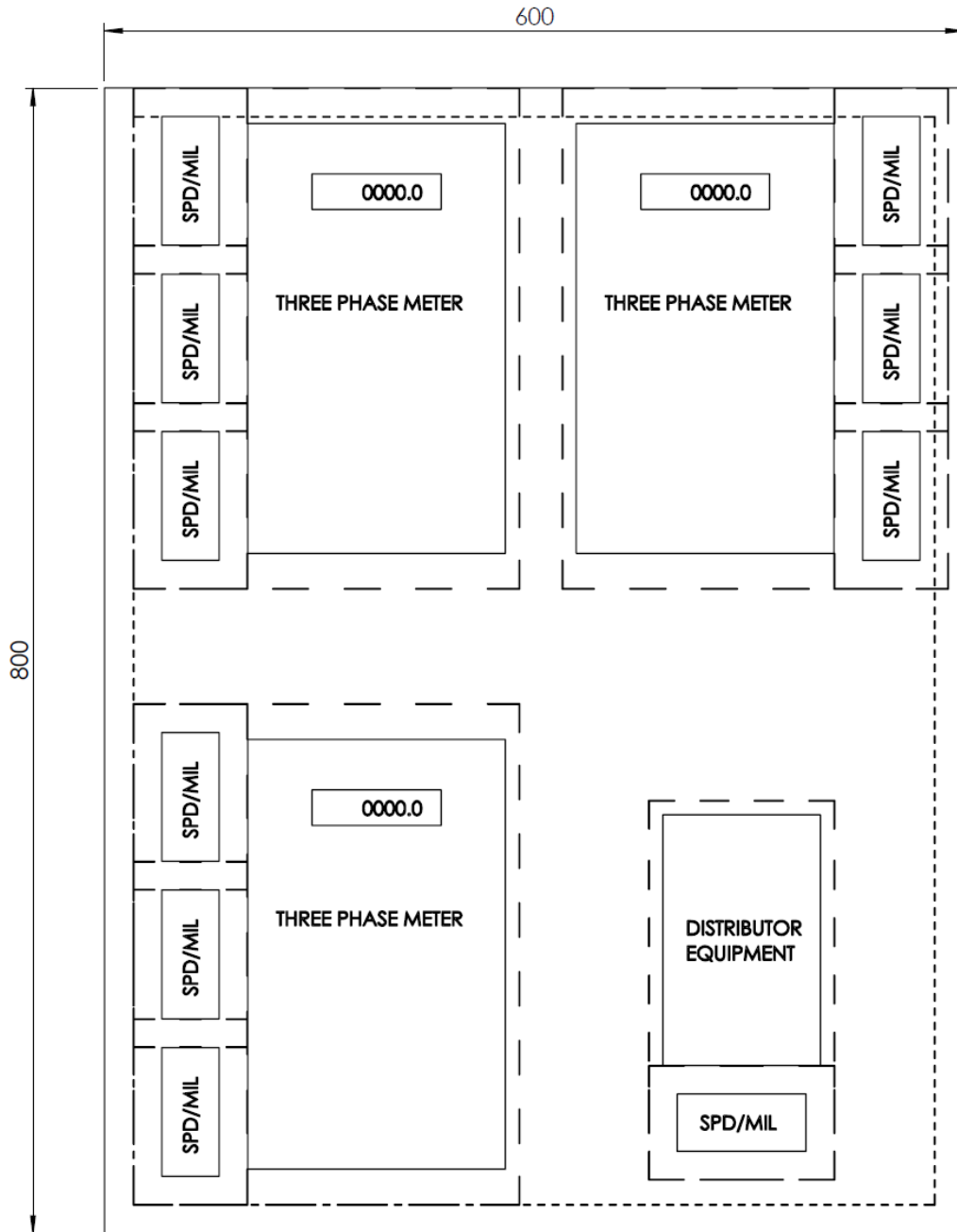

Figure 19 - Typical Panel Layout for Multi Occupancy, multiphase, 800 x 600 panel

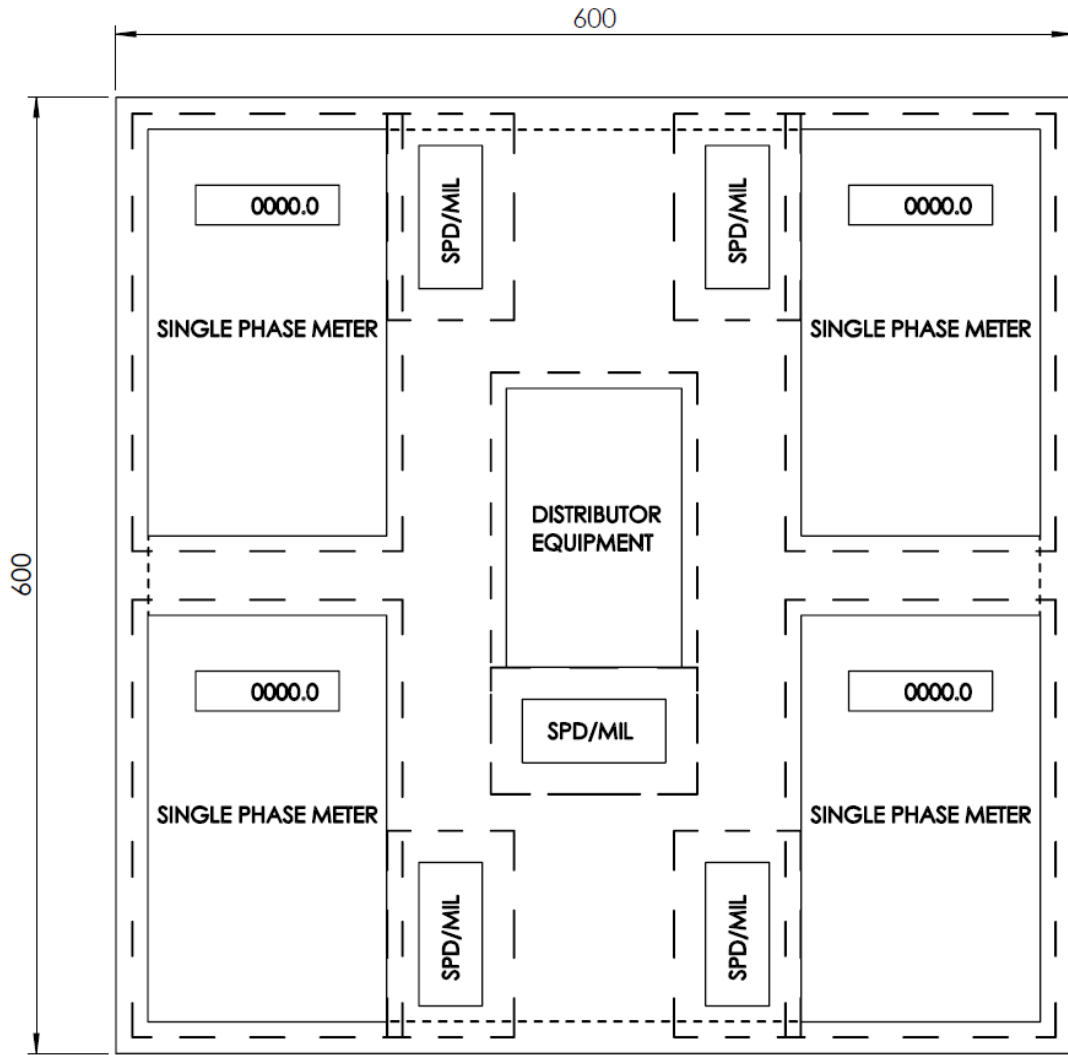

Figure 20 - Typical Panel Layout for Multi Occupancy, Single phase, 600 x 600 panel

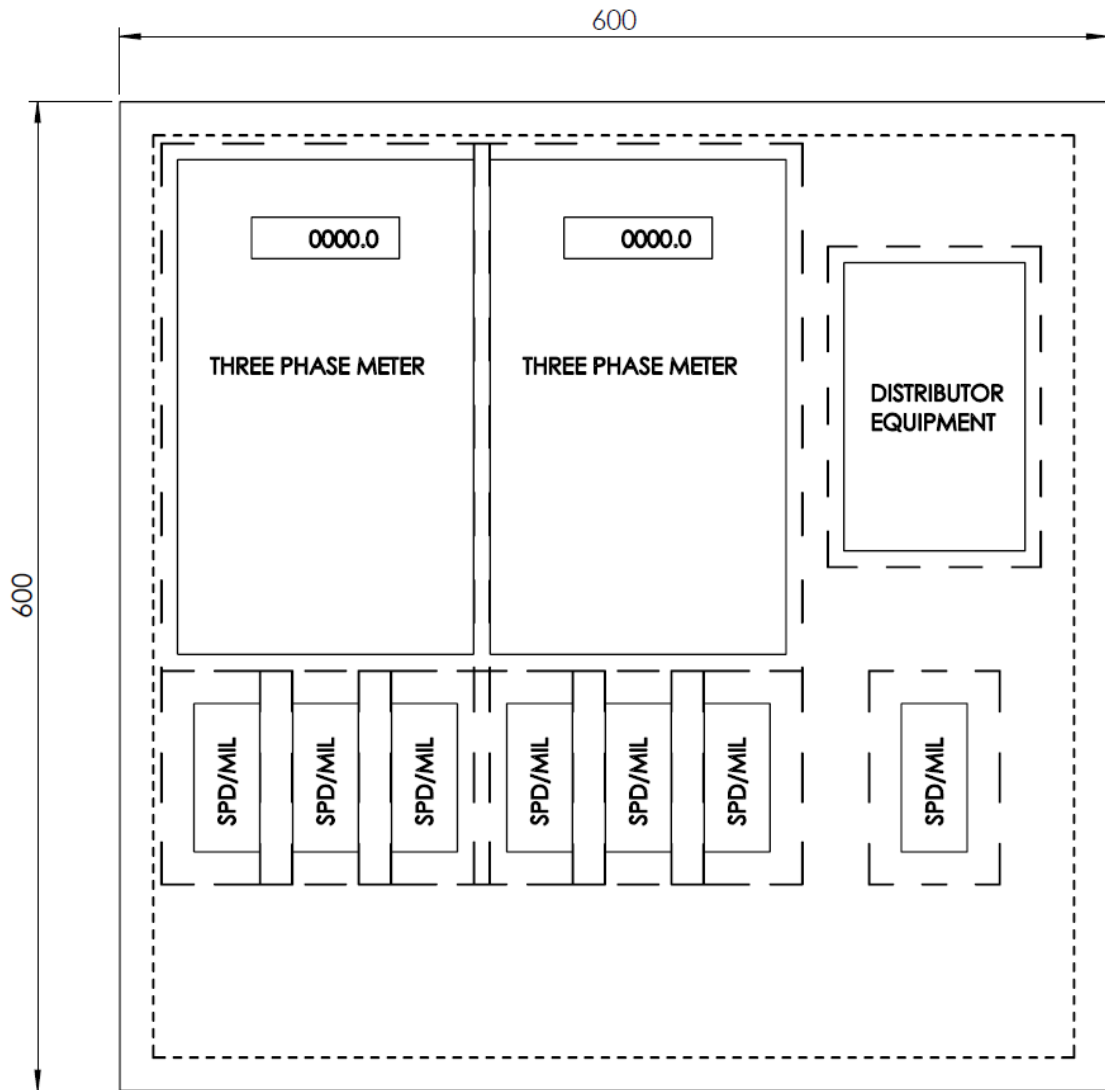

Figure 21 - Typical Panel Layout for Multi Occupancy, multiphase, 600 x 600 panel

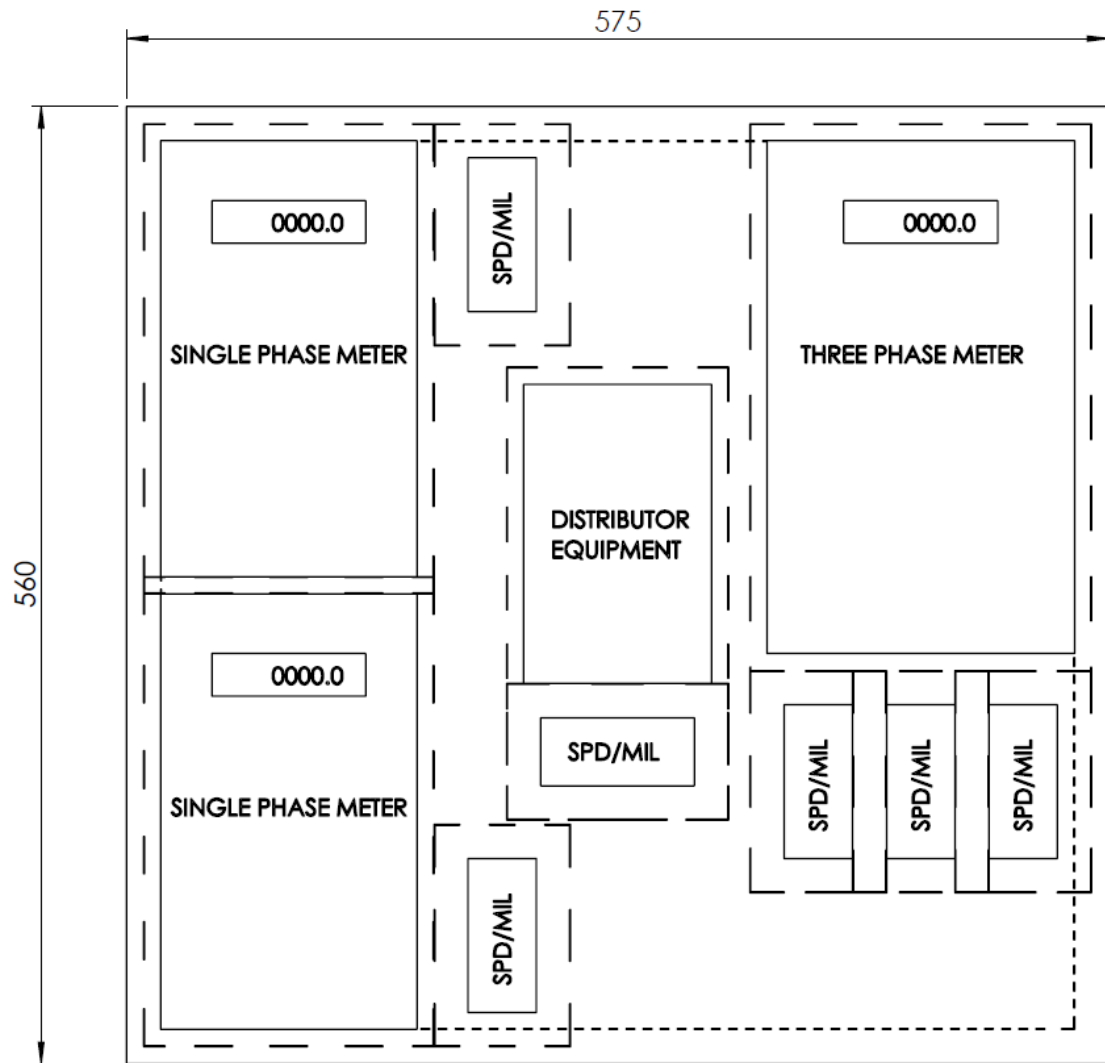

Figure 22 - Typical Panel Layout for Multi Occupancy, multiphase and single phase, 560 x 575 panel

Current Transformer Metering

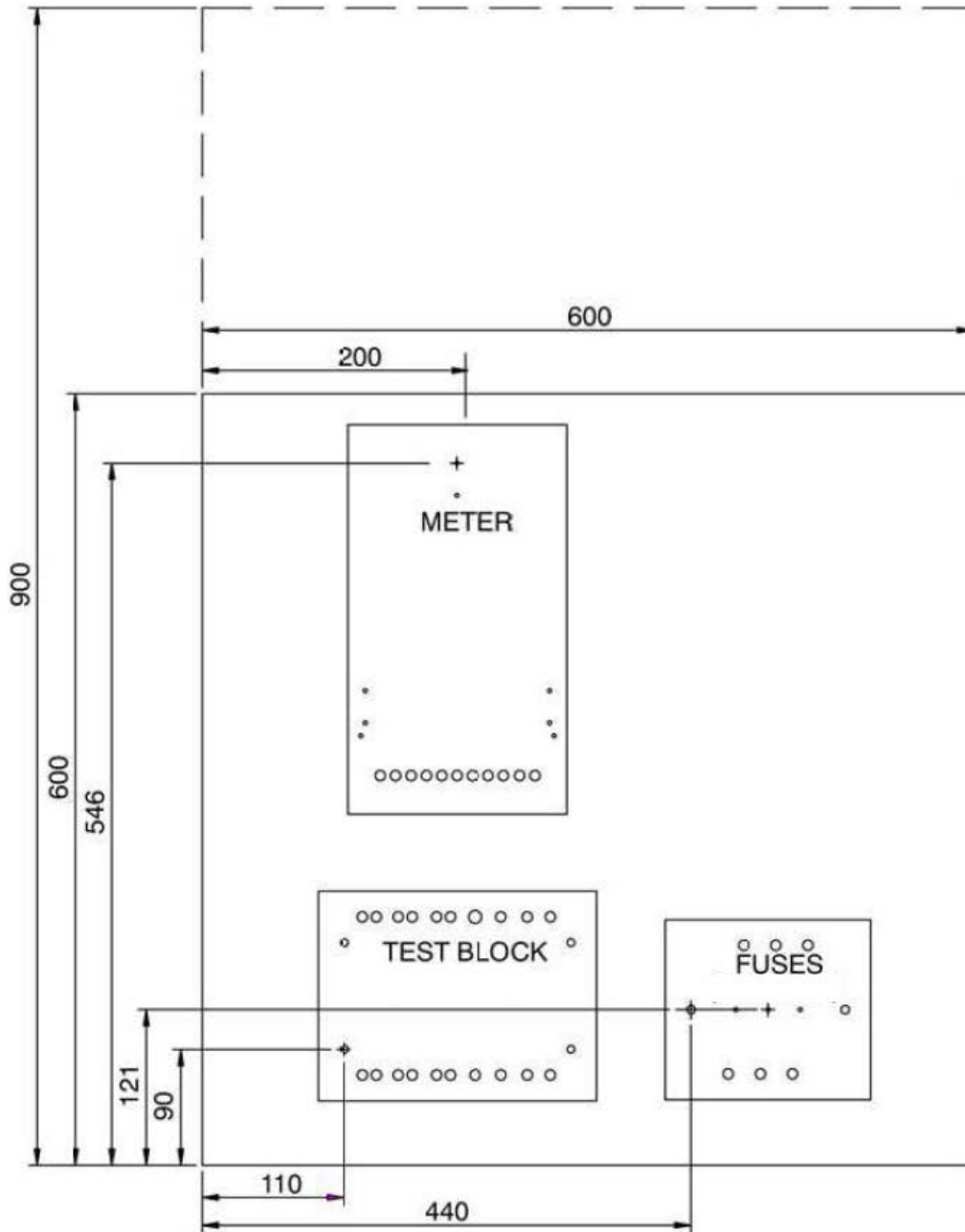

Figure 23 – Typical CT Meter Panel Equipment Placement

Appendix B – Low Voltage CT Layouts

General Arrangements for Metering Fuse Sealing Blocks

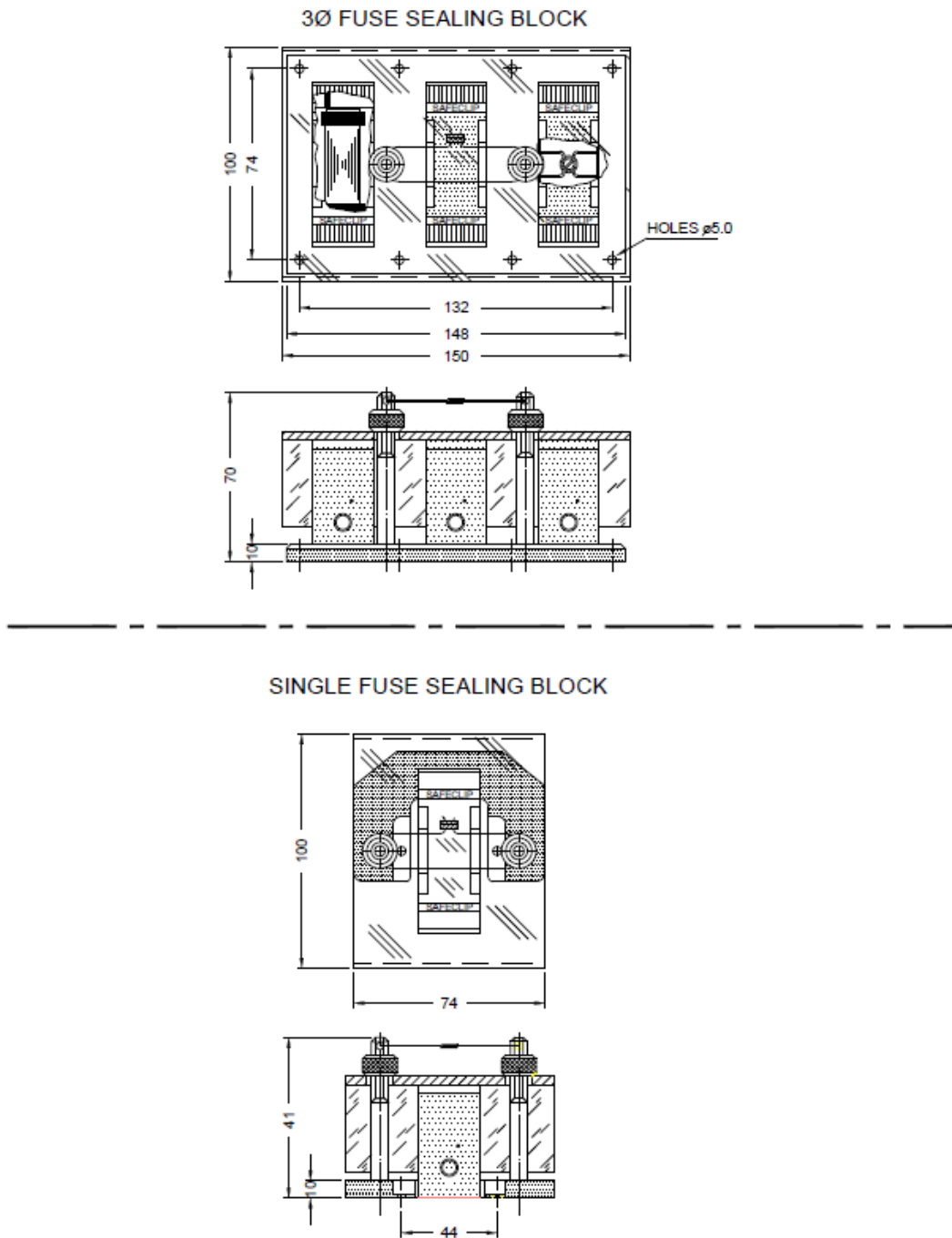
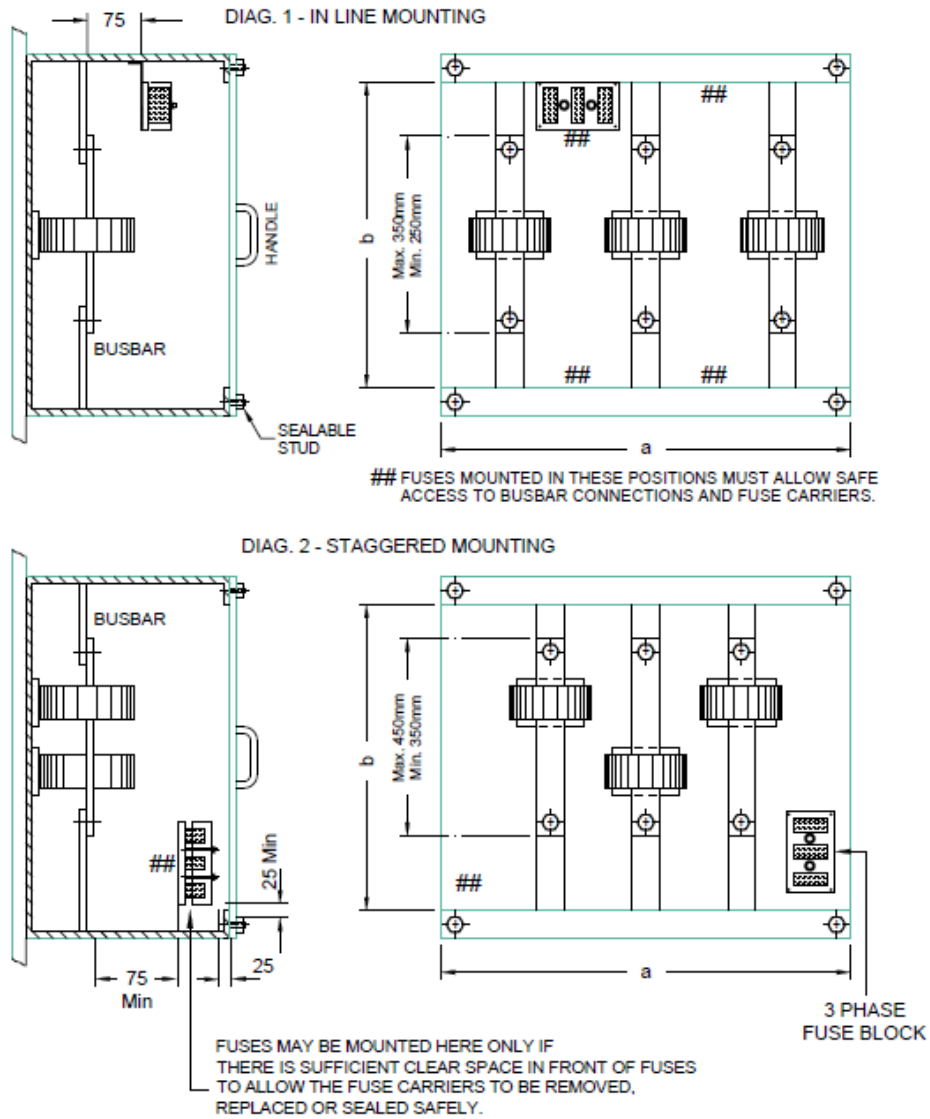

Figure 24 - General arrangement for metering fuse sealing blocks

Chamber Arrangements – Single Occupancy



NOTES:

1. VOLTAGE FUSE BLOCKS MAY BE MOUNTED ON EITHER FRONT OR SIDE OF ENCLOSURE FOR EACH CT. ARRANGEMENT.
2. ALL LIVE CONDUCTORS TO BE INSULATED - BUSBAR AND CABLE BOLTED CONNECTIONS TO BE COVERED WITH NON-ADHESIVE INSULATION, ADEQUATELY SECURED IN PLACE BY CABLE TIES.

Figure 25 - Typical CT chamber arrangements

Wiring Diagram – LV CT Metering Connections

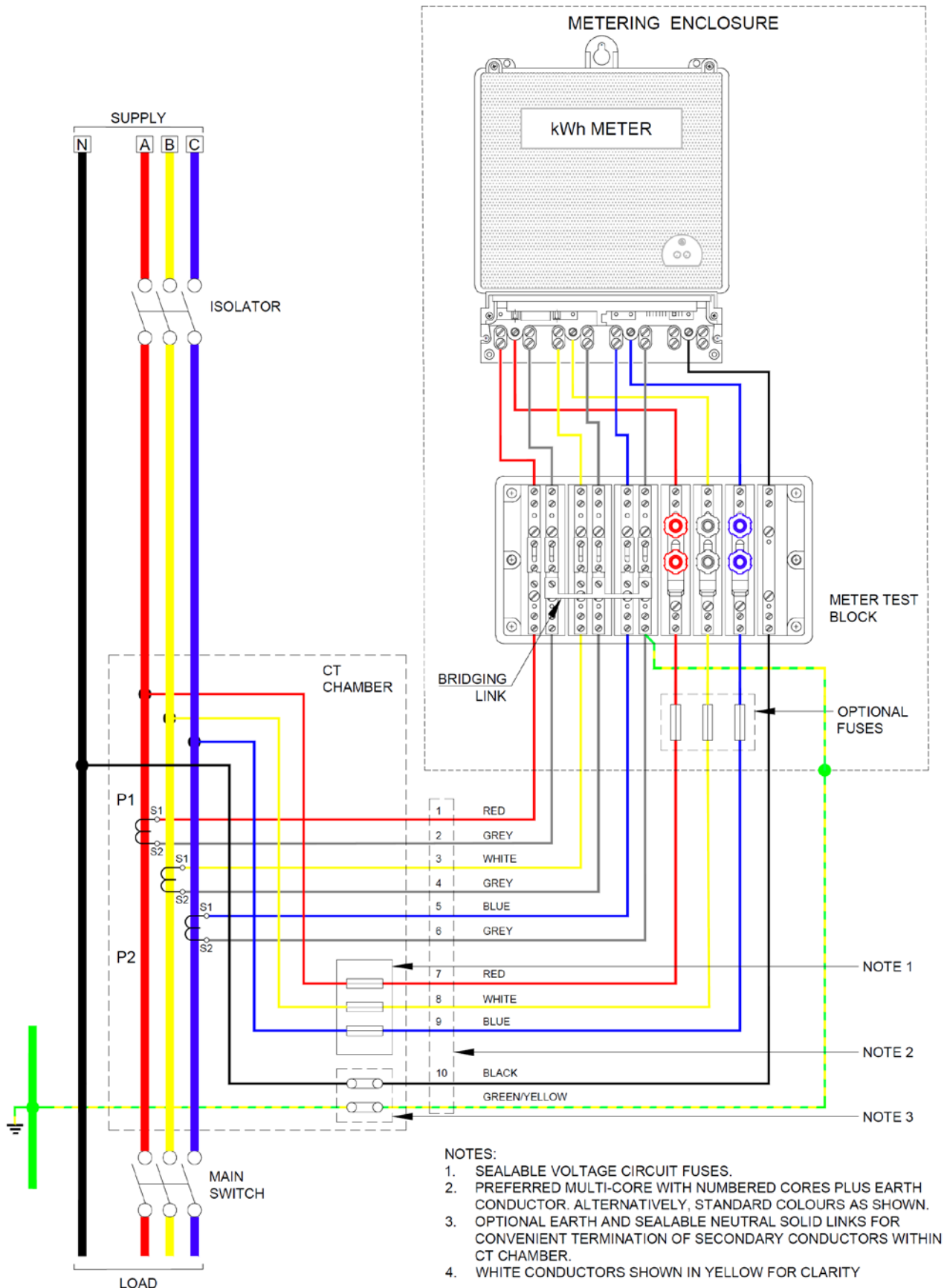

Figure 26 - Wiring Diagram for CT Metering

Appendix C – Specification for Test Blocks for Transformer-Operated Meters

(This appendix has been derived from the ESAA Standard No. S(b)7.-1976 as prepared by No.27 Committee, Metering of Section No.2 Transmission and Distribution, of the ESAA, as was adopted by the ESAA on 22nd October 1975.)

1 Scope

- 1.1 This specification applies to transformer-operated meter test blocks which may be installed on customers' premises to facilitate removal and site-testing of the metering installation.

2 Type

- 2.1 The test blocks shall be front-connected and provide for the connection of three-phase, three and four-wire meters with a current rating of 20A, and a voltage rating of 660V.
- 2.2 Each block *shall* provide for three current circuits, three voltage circuits and one neutral circuit.
- 2.3 Each voltage circuit *shall* be fitted with a slide link and two insulated nuts. The slide link *shall* be so insulated as to enable its manipulation while energised.
- 2.4 The neutral circuit *shall* be a solid bar without slide links.
- 2.5 Provision *shall* be made for the insertion of auxiliary instruments in the current, voltage and neutral circuits with the aid of 4 mm diameter test plugs.
- 2.6 Four mounting holes of not less than 6 mm diameter *shall* be provided in the base of the test blocks.
- 2.7 The construction of the test blocks *shall* comply with AS/NZS 61439.
- 2.8 The test blocks *shall* conform to the constructional and layout features shown in this appendix.
- 2.9 Two hardware arrangements differ in the following way:
 - Mk I having isolation facility on both polarity and non-polarity leg of the current circuit; and
 - Mk II having isolation facility on the polarity leg and the non-polarity as a solid bar.
- 2.10 The hardware can be equipped with additional components:
 - Bridging link to star-connect the non-polarity legs of the current circuits – locatable either on the meter side or the current transformer side of the current transformer isolation links.
 - Current transformer shorting swing links, located on the current transformer side of the isolation links. These links can be left open for normal operation, or closed, when access to the meter is required for tested.
- 2.11 The preferred arrangement is the Mk1 test block without current transformer shorting swing links, with bridging link star-connecting the non-polarity legs of the current circuits, located on the current transformer side of the isolation links. (See Figure 27). The reasoning for this preference is as follows:
 - The Mk1 test block, together with dedicated polarity and non-polarity wiring for each CT ensures independent operation of each current transformer, plus full access for testing and measurements;
 - Excluding the shorting swing links eliminates the potential to leave the current transformers shorted after leaving the site. Instead, by requiring the use of external shorting links, the cover is only able to be reinstated if the links are removed, thus discouraging the circumstances of leaving the current transformers shorted after leaving the site;
 - Star connecting the non-polarity on the current transformers, on the current transformer side, allows provision for referencing the secondary current transformers to earth potential for safety, at all times, irrespective of the position of isolation links

2.12 Alternative arrangements are and have been commonly used in different jurisdictions, including:

- Queensland (Figure 28)
- New South Wales, Australian Capital Territory (Figure 29)
- Victoria, South Australia, Tasmania (Figure 30)

3 General Construction

- 3.1 The test block base and cover and insulated portions of the voltage slide links and insulated nuts shall be of moulded insulating material or materials complying with AS/NZS61439. Insulating materials shall not be adversely affected by normal (operational) heat and abnormal heat. Glow-wire test principles of AS/NZS 61439.1 shall be used to verify the suitability of insulating materials.
- 3.2 All moulded material for the base *shall* be black except that the phases of the voltage links shall be identified by red, white and blue coloured insulated nuts.
- 3.3 Unless otherwise specified all current carrying metal parts shall be made of electro tin-plated brass suitable for electrical purposes. Any steel holding down screws shall be suitably protected against corrosion. Reference is drawn to AS/NZS 5112; Tunnel type terminal neutral bars for low voltage switchboards - Requirements for termination of copper conductors up to 50 mm² for verification of corrosion standards and testing.
- 3.4 ISO metric coarse pitch machine screw threads shall be used, except where otherwise specified.

4 Terminals

- 4.1 Cable terminals *shall* comply with AS/NZS 5112 and have tunnel entries, each having a diameter not less than 5 mm and length 14 mm. Each entry shall be countersunk.
- 4.2 Each terminal *shall* be provided with two brass cheese head 4 mm screws for effectively clamping the external conductor.
- 4.3 Access to the terminals *shall* be obtained by 9 mm diameter holes suitably placed in the faces of the moulded base.

5 Cover

- 5.1 The moulded cover shall effectively enclose all current carrying parts and shall extend beyond the top and bottom edges of the test block base. It shall provide clearances of not less than 18 mm between the external edges of the base and the internal edges of the cover. With the cover in position, no conductor, its insulation or any mounting screws shall be visible.

6 Sealing

- 6.1 Nonferrous nickel-plated knurled nuts suitable for sealing shall be provided for fixing the cover in position.
- 6.2 Sealing holes in nuts and studs shall be not less than 1.6 mm diameter.

General Arrangements for Metering Test Blocks

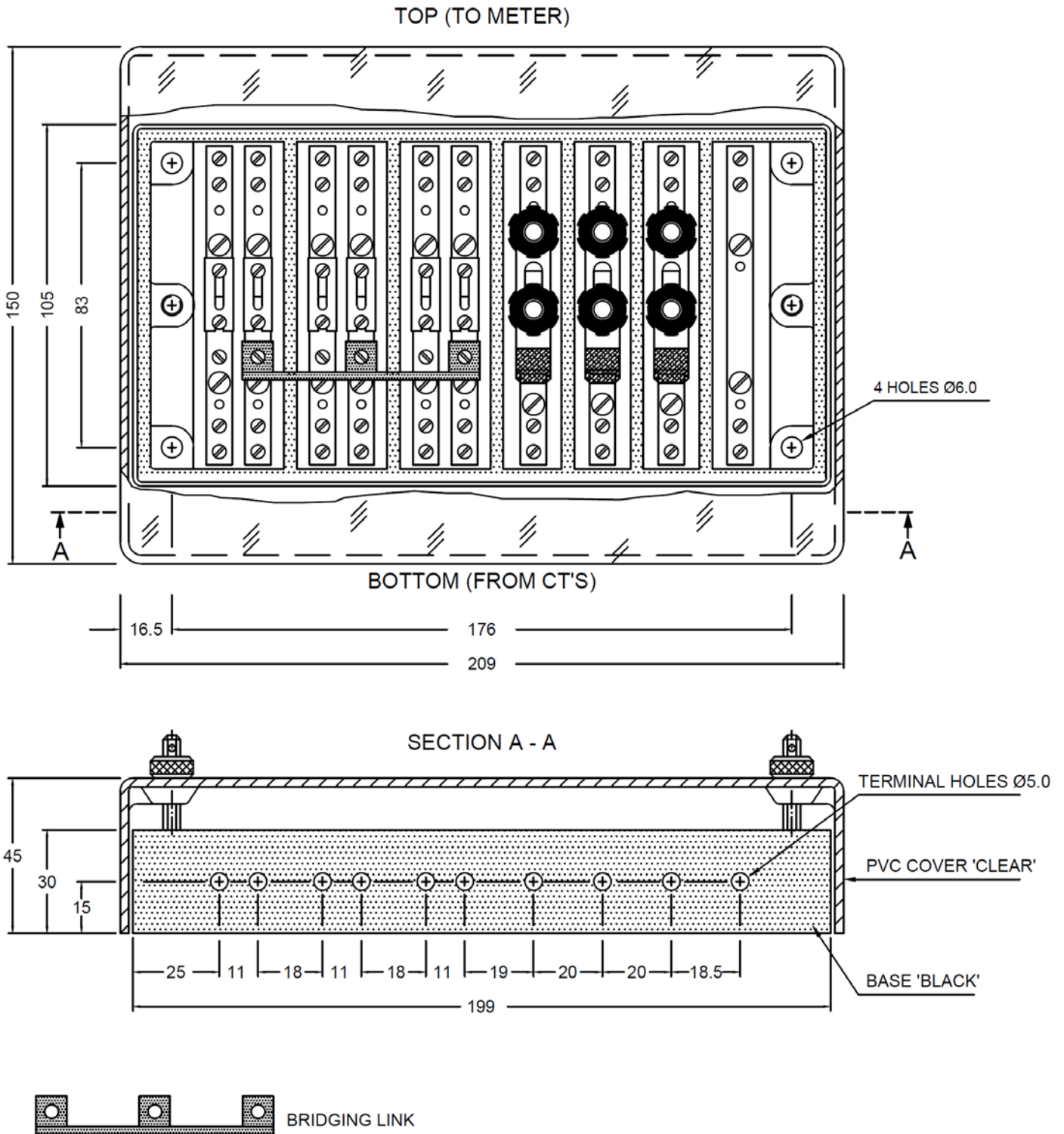

Figure 27 Preferred Test Block Arrangement

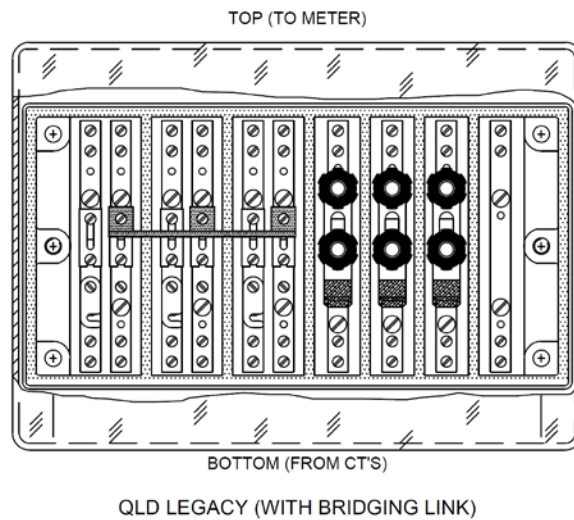

Figure 28 Mk1 Test block configuration commonly used in QLD

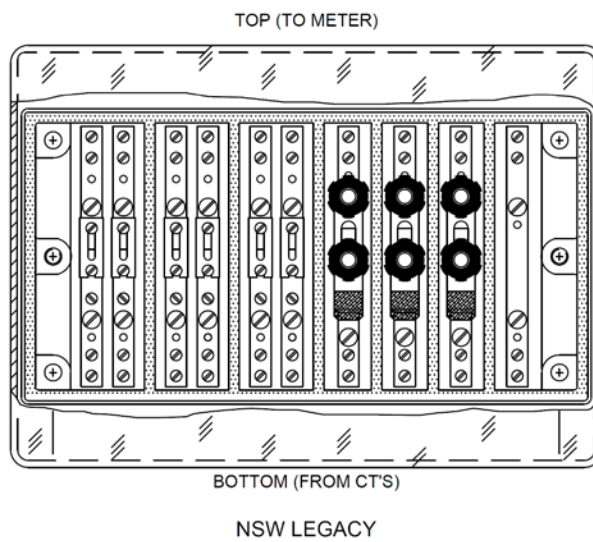

Figure 29 Mk1 Test block configuration commonly used in NSW and ACT

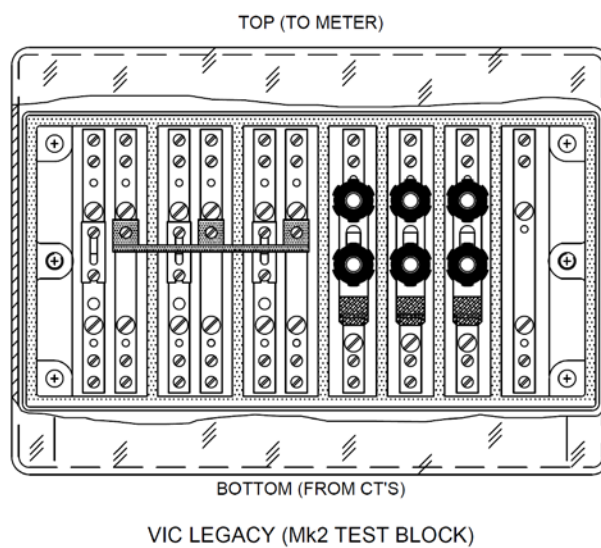

Figure 30 Mk2 Test block configuration commonly used in Vic, SA and Tas