

## E003+E004 Online test

## Ref 1

Four resistors 1 ohm, 2 ohm , 3 ohm and 4 ohm are connected in series to 5V. Calculate the circuit current & potential difference across each resistor.

A	1A,3V,2V,5V,7V	B	0.5A,0.5V,1V,1.5V,2V
C	3A,1V,5V,6V,7V	D	0.A,1V,2V,3V,4V
Answer			

## Ref 2

A 2.2K  $\Omega$  resistor is connected in series with a resistor of unknown value across 16V supply. If the current is 5 mA, calculate the value of unknown resistor.

A	1 K $\Omega$	B	3 K $\Omega$
C	4 K $\Omega$	D	2 K $\Omega$
Answer			

## Ref 3

Two resistors are connected in series to a 115V supply, one is known to have 470  $\Omega$  and voltage across it is 47V. Calculate (a) the value of second resistor (b) the circuit current.

A	100 $\Omega$ , 1A	B	800 $\Omega$ , 0.2A
C	680 $\Omega$ , 0.1A	D	1200 $\Omega$ ,0.1A
Answer			

## Ref 4

Resistors of 5  $\Omega$ , 10  $\Omega$  and 3  $\Omega$  are connected in parallel to 12V supply. Calculate the supply current.

A	4A	B	3A
C	1A	D	2A
Answer			

Ref 5

Resistors of  $33\text{K}\ \Omega$ , and  $68\text{K}\ \Omega$  are connected in parallel to  $50\text{V}$ . Calculate (a) total circuit resistance (b) total circuit current (c) individual branch currents.

A	$44.5\text{K}\ \Omega$ , $4.5\text{mA}$ , $3\text{mA}$ , $1.58\text{mA}$	B	$22.2\text{K}\ \Omega$ , $2.25\text{mA}$ , $1.5\text{mA}$ , $0.79\text{mA}$
C	$30\text{K}\ \Omega$ , $3\text{mA}$ , $2\text{mA}$ , $1\text{mA}$	D	$60\text{K}\ \Omega$ , $6\text{mA}$ , $4\text{mA}$ , $2\text{mA}$
<b>Answer</b>			

Ref 6

Resistors of values  $12\ \Omega$  and  $8\ \Omega$  are connected in parallel with  $R_3$  of unknown value across a  $6\text{V}$  supply. When the current from the supply is  $2.25\text{A}$ , calculate (a) the value of  $R_3$  (b) current flowing in  $R_3$ .

A	$12\ \Omega$ , $0.5\text{A}$	B	$6\ \Omega$ , $1\text{A}$
C	$24\ \Omega$ , $0.25\text{A}$	D	$8\ \Omega$ , $1.25\text{A}$
<b>Answer</b>			

Ref 7

Five resistors are connected as follows. Find (a)  $R_t$  (b)  $I_t$  (c)  $2\ \Omega$  resistor current.

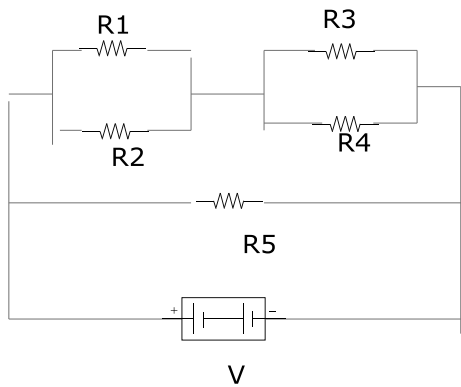

$R_1=2\ \Omega$ ,  $R_2=8\ \Omega$ ,  $R_3=3\ \Omega$ ,  $R_4=6\ \Omega$ ,  $R_5=7.2\ \Omega$ .  $V=6\text{V}$

A	$3.6\ \Omega$ , $5\text{A}$ , $2.66\text{A}$	B	$4.8\ \Omega$ , $5\text{A}$ , $7\text{A}$
C	$7.2\ \Omega$ , $7.5\text{A}$ , $4\text{A}$	D	$2.4\ \Omega$ , $2.5\text{A}$ , $1.33\text{A}$
<b>Answer</b>			

Ref 8

Resistors  $1.8\text{ K}\Omega$  and  $1.2\text{ K}\Omega$  are connected in series to  $12\text{V}$  supply. Calculate the power dissipated in each resistor and total power.

A	1W,0.5W,0.7W	B	0.0576W,0.0384W,0.096W
C	0.0144W,0.009W,0.024W	D	0.0288W,0.0192W,0.048W
Answer			

Ref 9

A  $1\ \Omega$  resistor is connected in series with parallel combination of  $6\ \Omega$  and  $3\ \Omega$  resistors to  $6\text{V}$  supply. Calculate (a)  $R_t$  (b) Each resistor current.

A	$3\ \Omega$ , 2A, 0.66A, 1.33A	B	$4\ \Omega$ , 1A, 2A, 3A
C	$10\ \Omega$ , 4A, 3A, 5A	D	$6\ \Omega$ , 1A, 1.32A, 2.66A
Answer			

Ref 10

Resistors of  $2.2\text{K}\ \Omega$  and  $7.88\text{K}\ \Omega$  are connected in series and parallel across  $3.3\text{K}\ \Omega$  and  $2.7\text{K}\ \Omega$  series combination. They are connected to  $9\text{V}$  supply. Calculate (a)  $R_t$  (b)  $I_t$  (c) Each resistor current.

A	$7.5\text{K}\ \Omega$ , 4.8mA,1.8mA,3mA	B	$3.75\text{K}\ \Omega$ , 2.4mA,0.9mA,1.5mA
C	$2\text{K}\ \Omega$ , 1.2mA,0.5mA,1mA	D	$10\text{K}\ \Omega$ , 8mA,2mA,3mA
Answer			

Ref 11

3 filament lamp indicators are each rated  $12\text{V}$  and  $0.36\text{ w}$ . If they are connected in series, what supply voltage should be used? Find supply voltage, the current and total power dissipated.

A	36V,0.03A,108W	B	108V,0.09A,3.24W
C	72V,0.06A,2.16W	D	18V,0.015A,0.54W
Answer			

Ref 12

A circuit is fed with a 9V supply but a 4V ground potential is required at the base of a transistor. If this voltage is to be derived from 12 K $\Omega$  resistor connected to ground. Calculate the value of second resistor forming potential divider.

A	15K $\Omega$	B	20K $\Omega$
C	30K $\Omega$	D	5K $\Omega$
Answer			

Ref 13

Find RX

If  $R_1=1000 \Omega$ ,  $R_2=1000 \Omega$ ,  $R_3=2715 \Omega$ ,  $V= 1.5V$  at bridge balanced condition.

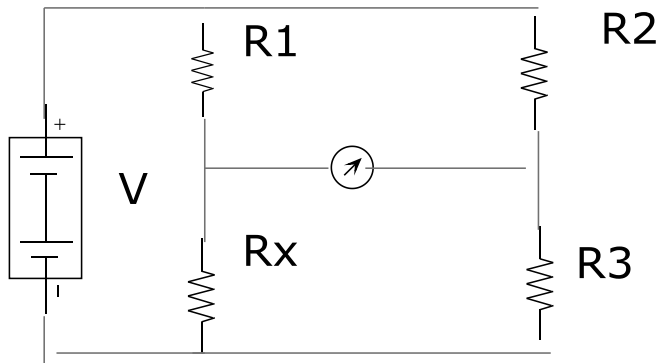

A	3000 $\Omega$	B	2715 $\Omega$
C	1000 $\Omega$	D	2000 $\Omega$
Answer			

Ref 15

A cell has emf 1.5V and internal resistance 0.5 ohm. Calculate its terminal voltage at (a) No load (b) providing 200mA current (c) when connected to a load of 8 ohm.

A	1.5V, 1.4V, 1.41V	B	6V, 1.4V, 1.4V
C	3V, 2.8V, 2.8V	D	3V, 1.4V, 1.41V
Answer			

Ref 16

A battery is made by connection 8 cells in series. Each has 1.5V and internal resistance 0.35 ohm. Calculate (a) EMF & internal resistance of battery. (b) The terminal voltage when supplying 400mA. (c) The current & terminal voltage when a load of resistance 20 ohm is connected to battery.

A	12V, 2.8 $\Omega$ , 5.1V	B	15V, 1.4 $\Omega$ , 5.1V
C	12V, 2.8 $\Omega$ , 10.11V	D	6V, 2.8 $\Omega$ , 10.11V
Answer			