

SECTION 6 DAMP SITUATIONS

6.1 GENERAL

6.1.1 Application

This Section specifies the minimum requirements for the selection and installation of electrical equipment in locations subject to the effects of water or high humidity (damp situations), that shall be achieved to satisfy Part 1 of this Standard.

6.1.2 Selection and installation

In addition to the requirements of Sections 2 to 5 of this Standard, electrical equipment used in damp situations shall be selected and installed to perform the following functions:

- (a) Provide enhanced protection against electric shock in locations where the presence of water or high humidity present an increased risk.

NOTE: This increased risk of electric shock is generated by a reduction in body resistance and the likelihood of contact of the body with earth potential.

- (b) Provide adequate protection against damage that might reasonably be expected from the presence of water or high humidity.

NOTE: Appendix G describes the IP system of classification of degrees of protection for electrical equipment.

The particular requirements for specific damp situations are additional to, replace, or modify the general requirements of the other Sections of this Standard. Where this Section does not specify a requirement, the relevant requirements of other Sections of this Standard apply.

This Section applies to the following damp situations:

- (i) Baths, showers and other fixed water containers.
- (ii) Swimming pools, paddling pools and spa pools or tubs.
- (iii) Fountains and water features.
- (iv) Saunas.
- (v) Refrigeration rooms.
- (vi) Sanitization and general hosing-down operations.

6.2 BATHS, SHOWERS AND OTHER FIXED WATER CONTAINERS

6.2.1 Scope

The particular requirements of this Clause (Clause 6.2) apply to electrical installations in locations containing a bath, shower or other fixed water containers and their surrounding zones, where the risk of electric shock is increased by a reduction in body resistance and the likelihood of the body making contact with the water and with conductive structure(s) in contact with the general mass of earth.

- * Other fixed water containers are those designed to contain water in normal use and do not include fortuitous containers or areas not intended to contain water for normal operations or water containers into which persons do not normally put a part or all of their body.

For the purposes of this Clause, a full chemical safety washdown facility, such as a deluge shower, in which a person can stand, shall be treated as a shower under Clause 6.2.2.1. In addition, a self-contained eyewash facility with a fixed or flexible hose shall be treated as a fixed water container under Clause 6.2.2.2.

The requirements of this Clause are based on the classification of zones surrounding the water container.

Barriers, such as screens, doors, curtains and fixed partitions that provide effective protection against spraying water may be used to limit the extent of a classified zone.

Ceilings, walls with or without windows, doors and floors that limit the extent of rooms containing a bath, shower or other water container also limit the associated zones.

- * Due to the nature of these locations, certain methods of protection against electric shock are not permitted. Refer to Clause 6.2.3.

NOTES:

- 1 For locations containing baths for medical treatment, special requirements may be necessary.
- 2 Electrical equipment installed behind a fixed panel that provides a degree of protection not less than IPX4 and to which access may only be gained by the use of a tool would not be considered to be in a classified zone.
- 3 Electrical equipment recessed into a ceiling such that all live parts are above the lower surface of the ceiling is considered to be outside any zone immediately below the ceiling.

6.2.2 Classification of zones

6.2.2.1 Baths and showers

Four zones (Zones 0, 1, 2 and 3) are classified for baths and showers:

- (a) Zone 0 shall be the area of the interior of a bath or a shower base.

NOTE: A shower base may be defined by either a raised hob or a depression in the floor.

- (b) Zone 1 for a bath shall be the area limited by the following:
- (i) Zone 0.
 - (ii) The vertical projection of the internal rim of the bath above Zone 0.
 - (iii) When the bath contains a shower, by the vertical plane 1.2 m radius from the shower fixed plumbing connection.
 - (iv) In Australia, by the floor and a horizontal plane 2.5 m above the floor. A
 - (v) In New Zealand, by the floor and a horizontal plane 2.25 m above the floor. NZ
 - (vi) The height of the fixed plumbing connection, if higher than the horizontal plane specified in Item (iv) or (v).

NOTE: A barrier of a height at which the shower connection is made to the fixed plumbing, or 1.8 m, whichever is the greater, may be used to reduce the 1.2 m dimension in Item (b)(iii).

- (c) Zone 1 for a shower shall be the area limited by the following:
- (i) Zone 0.
 - (ii) For a fixed plumbing connection on the wall, by the vertical plane 1.2 m radius from the fixed plumbing connection. A barrier of a height at which the shower connection is made to the fixed plumbing, or 1.8 m, whichever is the greater, may be used to reduce the 1.2 m dimension.
 - * (iii) For a fixed plumbing connection on the ceiling, by the vertical plane horizontally distant from the fixed plumbing connection, and as follows:
 - (A) In Australia, a radius of 0.6 m. A
Exception: A barrier with a minimum height of 1.8 m may be used to reduce the 0.6 m dimension.
 - (B) In New Zealand, a radius of 1.2 m. NZ
Exception: A barrier with a minimum height of 1.8 m may be used to reduce the 1.2 m dimension.
 - (iv) In Australia, by the floor and a horizontal plane 2.5 m above the floor. A
 - (v) In New Zealand, by the floor and a horizontal plane 2.25 m above the floor. NZ
 - (vi) The height of the fixed plumbing connection, if higher than the horizontal plane specified in Item (iv) or (v).

NOTE: Examples of barriers include a hinged or sliding door, or a shower curtain.

- (d) Zone 2 shall be the area limited by—
 - (i) the vertical plane limiting Zone 1 and the parallel vertical plane 0.6 m external to Zone 1; and
 - (ii) the floor and the horizontal plane 2.25 m above the floor.
- (e) Zone 3 shall be the area limited by the following:
 - (i) The vertical plane limiting Zone 2 and the parallel vertical plane 2.4 m external to Zone 2.
 - (ii) In Australia, by the floor and a horizontal plane 2.5 m above the floor. A
 - (iii) In New Zealand, by the floor and a horizontal plane 2.25 m above the floor. NZ
 - (iv) In Australia, Zone 3 shall include the area above Zone 2 up to 2.5 m above the floor. A

Examples of these zones are shown in Figures 6.1 to 6.11.

6.2.2.2 Other fixed water containers

Two zones (Zones 0 and 2) are classified for fixed water containers other than baths and showers:

- (a) Zone 0 shall be the area of the interior of the water container.
- * (b) Zone 2 for an individual water container with a capacity not exceeding 40 L, and having fixed water outlets, shall be the area limited by—
 - (i) the vertical plane 0.15 m from the internal rim of the water container; and
 - (ii) the floor and the horizontal plane 0.4 m above the water container.

NOTE: Figure 6.12 shows a typical double bowl sink where the capacity of each container does not exceed 40 L.
- * (c) Zone 2 for water containers having either a capacity exceeding 40 L, or a water outlet through a flexible hose, shall be the area limited by—
 - (i) the vertical plane 0.5 m from the internal rim of the water container; and
 - (ii) the floor and the horizontal plane 1.0 m above the water container.

Examples of these zones are shown in Figures 6.13 and 6.14.

NOTES:

- 1 There is no Zone 1 or 3 for these water containers.
- 2 An example of a water outlet through a flexible hose is a vegetable sprayer.

6.2.3 Protection against electric shock—Prohibited measures

The following measures of protection against electric shock are prohibited and shall not be used:

- (a) Protection by means of obstacles, in accordance with Clause 1.5.4.5.
- (b) Protection by placing out of reach, in accordance with Clause 1.5.4.6.

6.2.4 Selection and installation of electrical equipment

6.2.4.1 Degree of protection required

Electrical equipment permitted to be installed in a classified zone shall have at least the following degree of protection:

- (a) In Zone 0—IPX7.
- (b) In Zones 1 and 2—IPX5 in communal baths/showers; IPX4 in other locations.
- (c) In Zone 3—IPX5 in communal baths/showers; no specific degree of protection in other locations.

The requirements for selection and installation of electrical equipment are provided in Table 6.1.

6.2.4.2 Socket-outlets

Socket-outlets shall not be installed within 0.3 m of the floor of a bathroom, laundry or other similar location where the floor is likely to become wet.

Regardless of the degree of protection provided by the equipment, the following requirements apply to the installation of socket-outlets in classified zones:

- (a) *Zone 0 and Zone 1* Socket-outlets shall not be installed in Zone 0 or 1.
- (b) *Zone 2* Socket-outlets installed in Zone 2 shall be—
 - (i) of the automatic switching type incorporated in a shaver supply unit complying with AS/NZS 3194; or
 - (ii) protected by an RCD with a fixed rated residual current not exceeding 30 mA and enclosed in a cupboard that maintains the enclosure of the socket-outlet during normal operation of the connected equipment.
- (c) *Zone 3* Socket-outlets installed in Zone 3 shall be—
 - (i) protected by an RCD with a fixed rated residual current not exceeding 30 mA;
 - (ii) supplied individually as a separated circuit, in accordance with Clause 7.4; or
 - (iii) supplied as an SELV or a PELV system, in accordance with Clause 7.5.

6.2.4.3 *Switches and other accessories*

Switches and other accessories shall not be installed within 0.3 m of the floor of a bathroom, laundry or other similar location where the floor is likely to become wet.

The following requirements apply to the installation of switches and other accessories in classified zones:

- (a) *Zone 0* Switches and other accessories shall not be installed in Zone 0.
- (b) *Zone 1 and Zone 2* Only switches and accessories with at least the required degree of protection shall be installed in Zones 1 and 2.

6.2.4.4 *Luminaires*

The following requirements apply to the installation of luminaires in classified zones:

- (a) *Zone 0* Luminaires installed in Zone 0 shall be—
 - (i) provided with the required degree of protection;
 - (ii) designed and constructed specifically for use in a bath, shower or water container;
 - (iii) supplied at a nominal voltage not exceeding 12 V a.c. or 30 V ripple-free d.c.; and
 - (iv) supplied from a source located outside Zone 0 as an SELV or a PELV system, in accordance with Clause 7.5.
- (b) *Zones 1, 2 and 3* Luminaires installed in Zones 1, 2 and 3 shall be provided with at least the required degree of protection.

Exceptions: Regardless of the degree of protection provided by the equipment, the following luminaires may be installed in Zone 2:

1 Luminaires of Class II construction (double or reinforced insulation) that require the removal of a cover to access lamps.

NOTE: A batten holder is not a Class II luminaire.

2 Luminaires supplied from a source located outside Zone 2 as an SELV or a PELV system, in accordance with Clause 7.5.

6.2.4.5 *Other electrical equipment*

The following requirements apply to the installation of appliances and other electrical equipment in classified zones:

- (a) *Zone 0* Appliances and other electrical equipment installed in Zone 0 shall be—
 - (i) designed and constructed specifically for use in a bath, shower or water container;
 - (ii) provided with the required degree of protection; and

- (iii) supplied—
 - (A) from a source located outside Zone 0;
 - (B) at a nominal voltage not exceeding 12 V a.c. or 30 V ripple-free d.c.; and
 - (C) as an SELV or a PELV system, in accordance with Clause 7.5.
- (b) *Zones 1, 2 and 3* Appliances and other electrical equipment installed in Zones 1, 2 and 3 shall be provided with at least the required degree of protection for the particular zone.

Heating cable systems intended for heating the location, and that are embedded in the floor and protected in accordance with Clause 4.10, may be installed.

6.2.4.6 *Switchboards*

A switchboard shall not be located within any classified zone.

6.2.4.7 *Electricity generation systems*

- * Electricity generation systems, including engine-driven generator sets, stand-alone power systems, grid-connected inverter systems and battery systems shall not be installed within any classified zone.

TABLE 6.1

SELECTION AND INSTALLATION OF ELECTRICAL EQUIPMENT FOR BATHS, SHOWERS AND OTHER FIXED WATER CONTAINERS

Equipment	Zone 0	Zone 1	Zone 2	Zone 3
Clause 6.2.4.2— Socket-outlets	Not permitted	Not permitted	(a) A shaver outlet; or (b) RCD-protected and in a cupboard (no specific IP rating).	(a) <0.3 m not permitted (b) ≥0.3 m no IP rating† but shall have— (i) RCD protection; (ii) separated supply; or (iii) SELV or PELV supply.
Clause 6.2.4.3— Switches/ accessories	Not permitted	Same as Zone 2	<0.3 m not permitted ≥0.3 m IPX4†	<0.3 m not permitted ≥0.3 m—No IP rating†

(continued)

TABLE 6.1 (continued)

Equipment	Zone 0	Zone 1	Zone 2	Zone 3
Clause 6.2.4.4— Luminaires	IPX7 and specifically for use and SELV or PELV supply	IPX4†	IPX4†; or Class II construction (double or reinforced insulation); or SELV or PELV; or recessed into ceiling	No IP rating†
Clause 6.2.4.5— Other electrical equipment	IPX7 and specifically for use and SELV or PELV supply	IPX4†	IPX4†; or recessed into ceiling	No IP rating†
Clause 6.2.4.6— Switchboards	Not permitted	Not permitted	Not permitted	Not permitted
* Clause 6.2.4.7— Electricity generation systems	Not permitted	Not permitted	Not permitted	Not permitted

† Degree of protection IPX5 required in communal baths/showers.

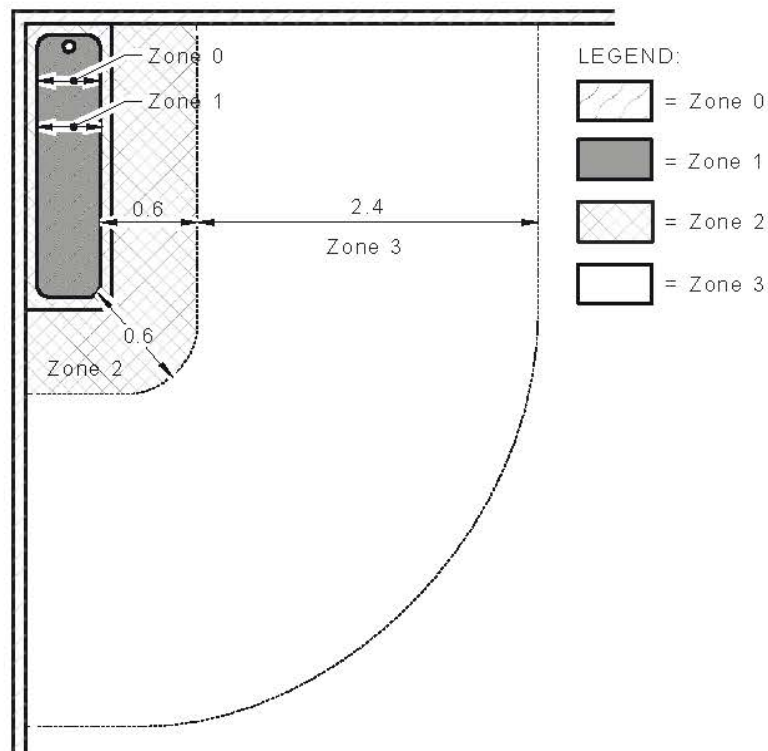



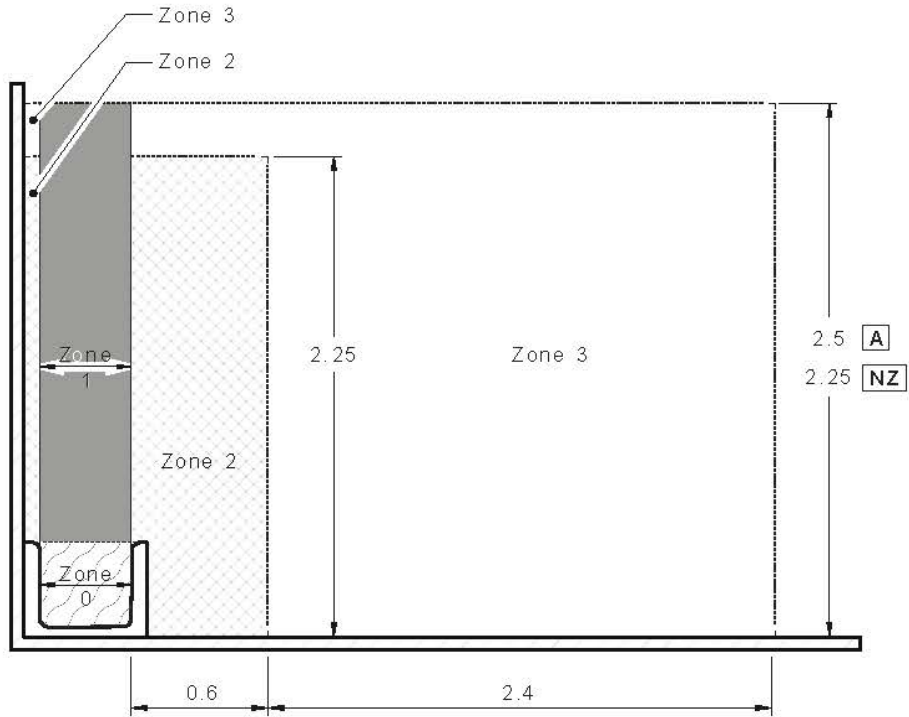

DIMENSIONS IN METRES

FIGURE 6.1 ZONE DIMENSIONS (PLAN)—
BATH WITHOUT SHOWER OR FIXED BARRIER



LEGEND:

-  = Zone 0
-  = Zone 1
-  = Zone 2
-  = Zone 3

DIMENSIONS IN METRES

FIGURE 6.2 ZONE DIMENSIONS (ELEVATION)—
BATH WITHOUT SHOWER OR FIXED BARRIER

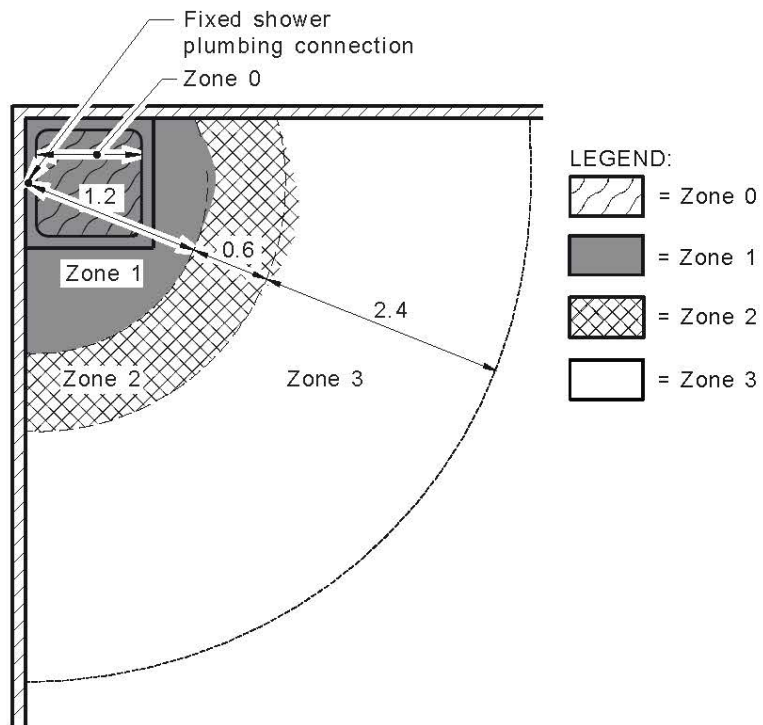

DIMENSIONS IN METRES

FIGURE 6.3 ZONE DIMENSIONS (PLAN)—SHOWER WITH FIXED PLUMBING CONNECTION ON WALL AND BASE WITHOUT BARRIERS

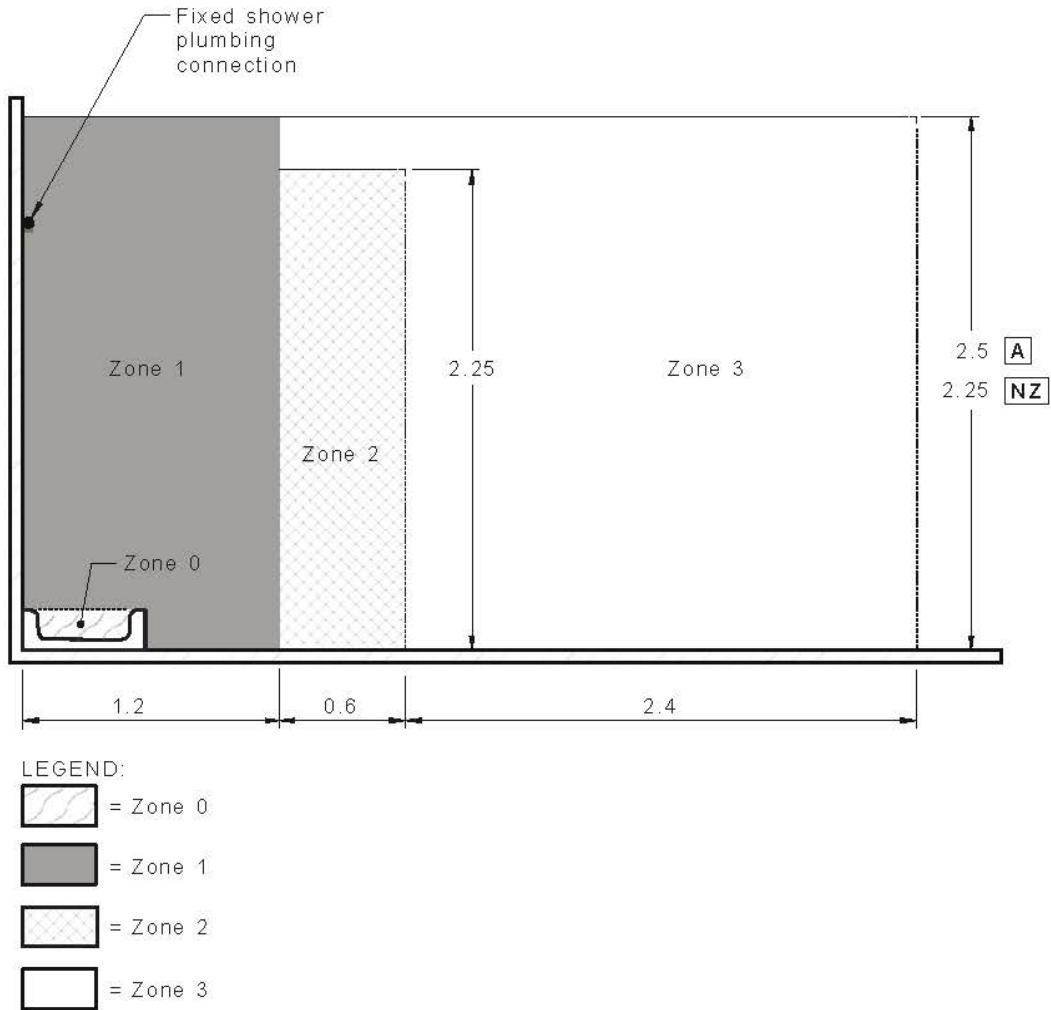

DIMENSIONS IN METRES

FIGURE 6.4 ZONE DIMENSIONS (ELEVATION)—SHOWER WITH FIXED PLUMBING CONNECTION ON WALL AND BASE WITHOUT BARRIERS

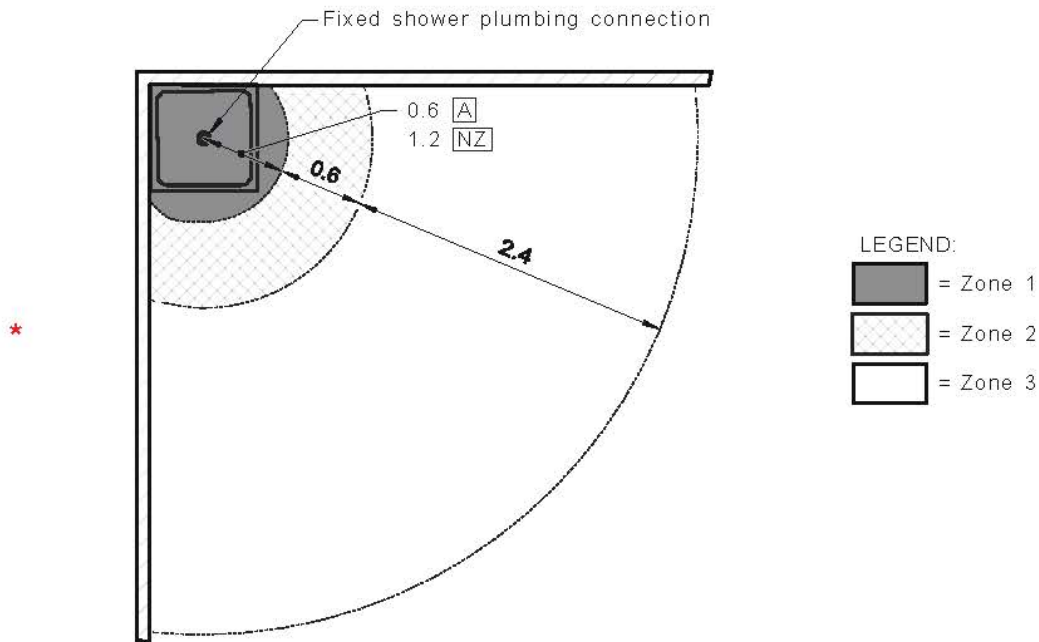

NOTE: Limitation of zones by barriers or enclosures apply, as they do for wall-mounted plumbing connections.

DIMENSIONS IN METRES

FIGURE 6.5 BATHS AND SHOWERS, ZONE DIMENSIONS (PLAN)—
SHOWER WITH FIXED PLUMBING CONNECTION ON CEILING
AND WITHOUT BARRIERS

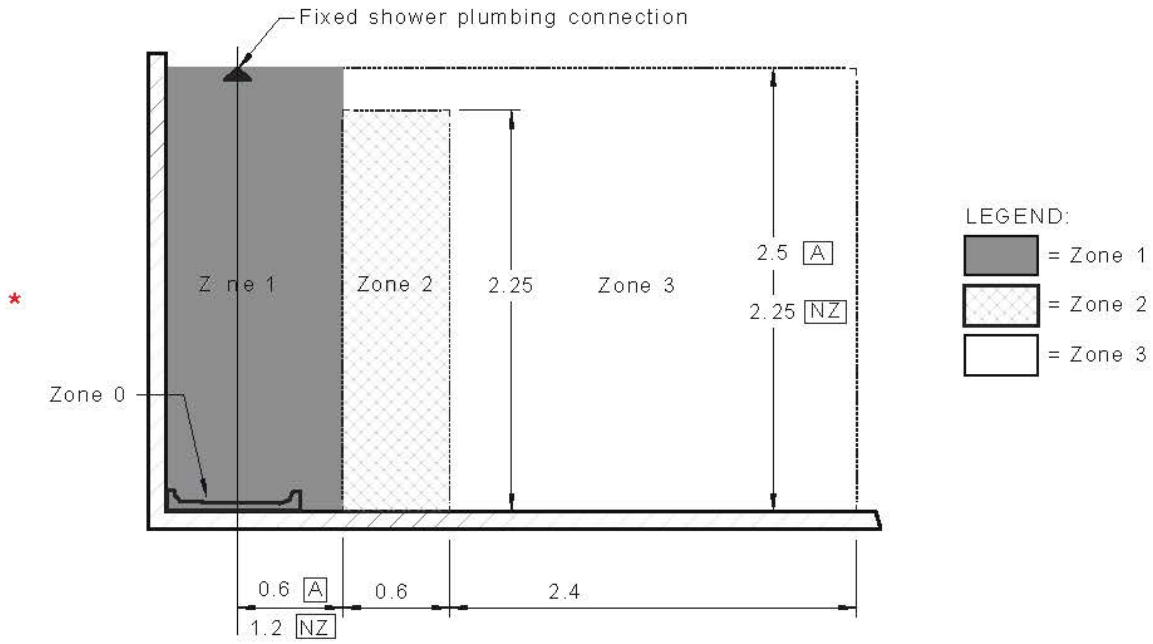

DIMENSIONS IN METRES

FIGURE 6.6 BATHS AND SHOWERS, ZONE DIMENSIONS (ELEVATION)—
SHOWER WITH FIXED PLUMBING CONNECTION ON CEILING
AND WITHOUT BARRIERS

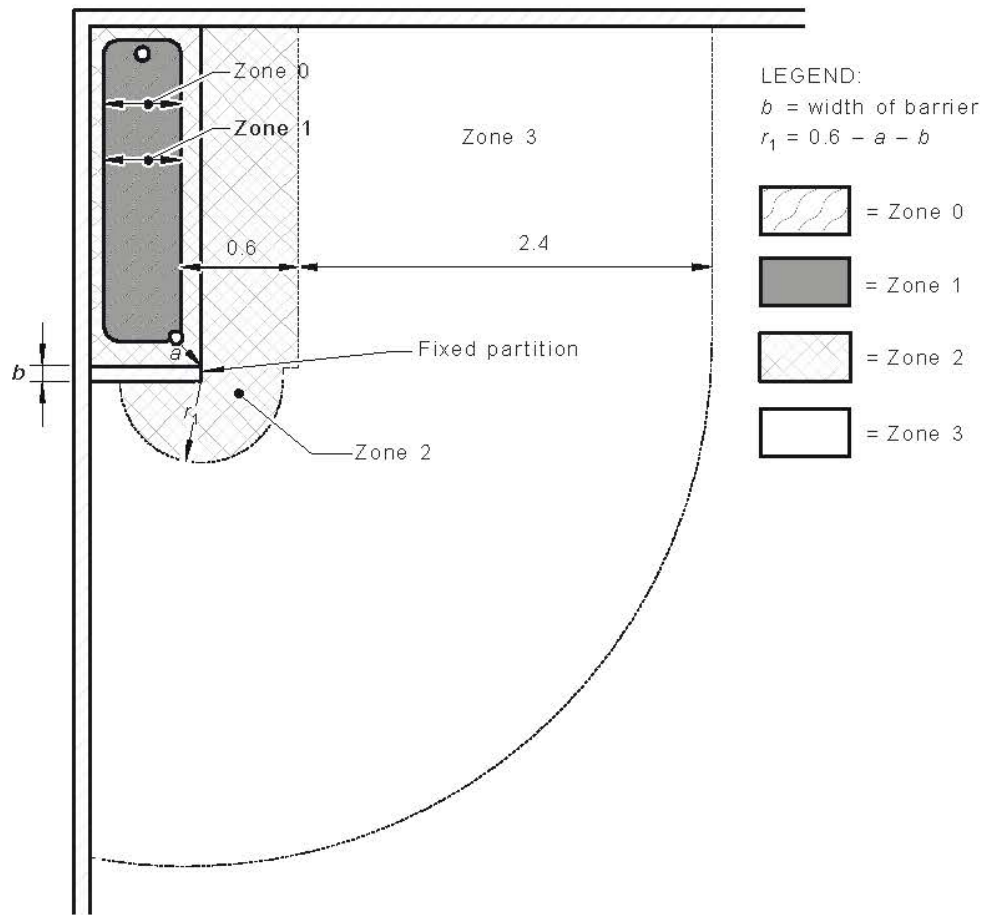

DIMENSIONS IN METRES

FIGURE 6.7 ZONE DIMENSIONS (PLAN)—
BATH WITHOUT SHOWER WITH FIXED BARRIER

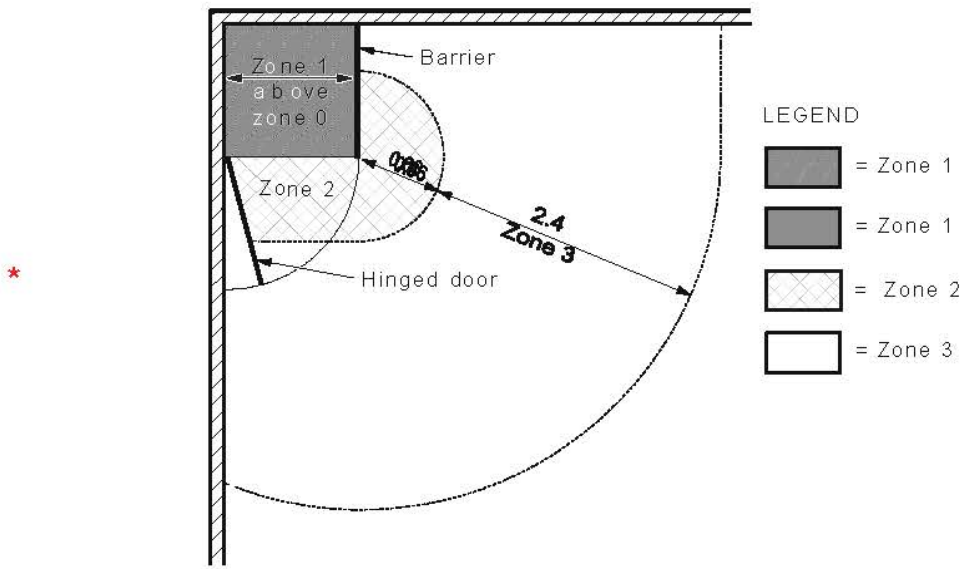

DIMENSIONS IN METRES

FIGURE 6.8 ZONE DIMENSIONS (PLAN)—
ENCLOSED SHOWER WITH HINGED DOOR

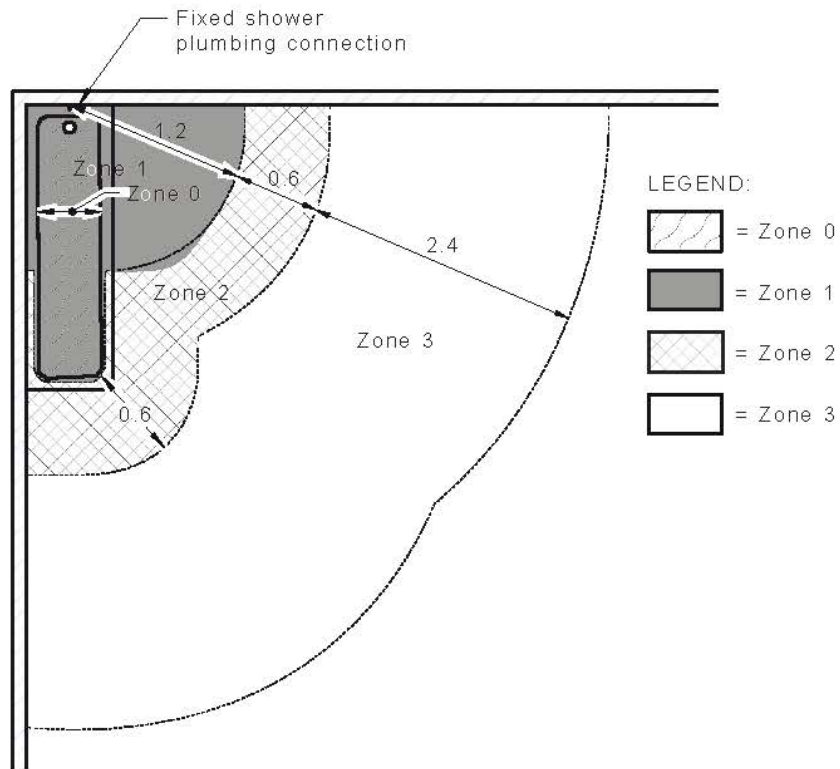

DIMENSIONS IN METRES

FIGURE 6.9 ZONE DIMENSIONS (PLAN)—
BATH WITH SHOWER WITHOUT BARRIER

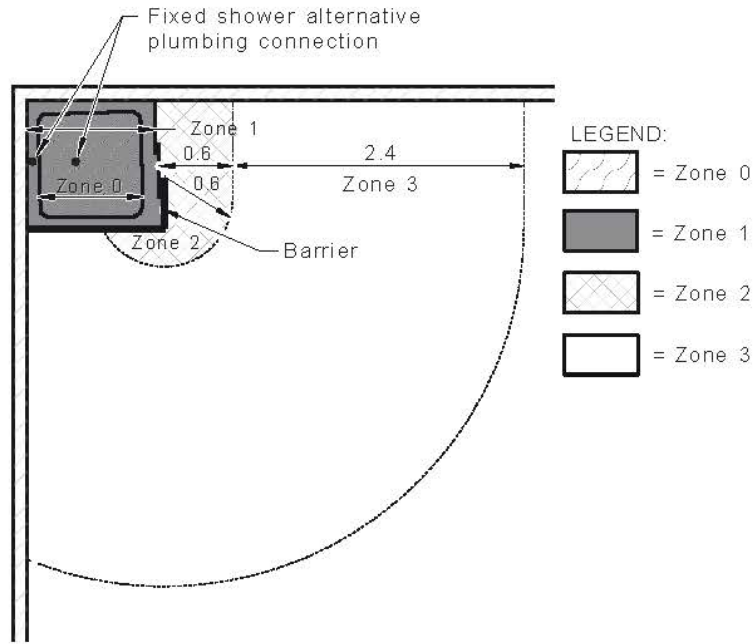

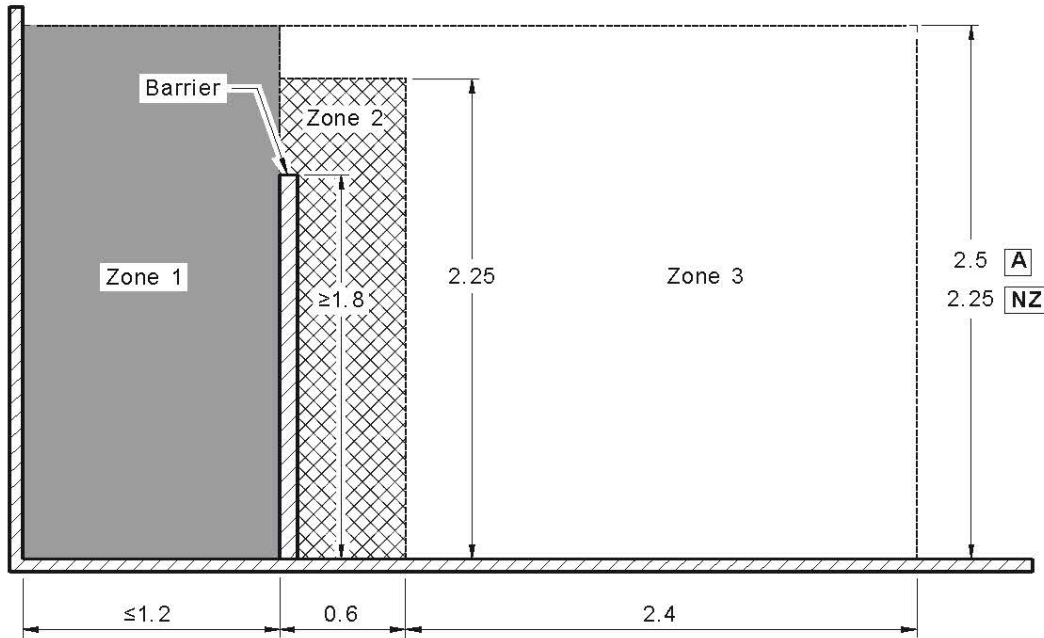

DIMENSIONS IN METRES

FIGURE 6.10 ZONE DIMENSIONS (PLAN)—ENCLOSED SHOWER WITH FIXED PLUMBING CONNECTION ON CEILING OR WALL AND A BARRIER



LEGEND:

-  = Zone 1
-  = Zone 2
-  = Zone 3

NOTE: Refer to Clause 6.2.2.1(a) for Zone 0.

DIMENSIONS IN METRES

* FIGURE 6.11 ZONE DIMENSIONS (ELEVATION)—SHOWER WITH FIXED PLUMBING CONNECTION ON CEILING OR WALL AND A BARRIER

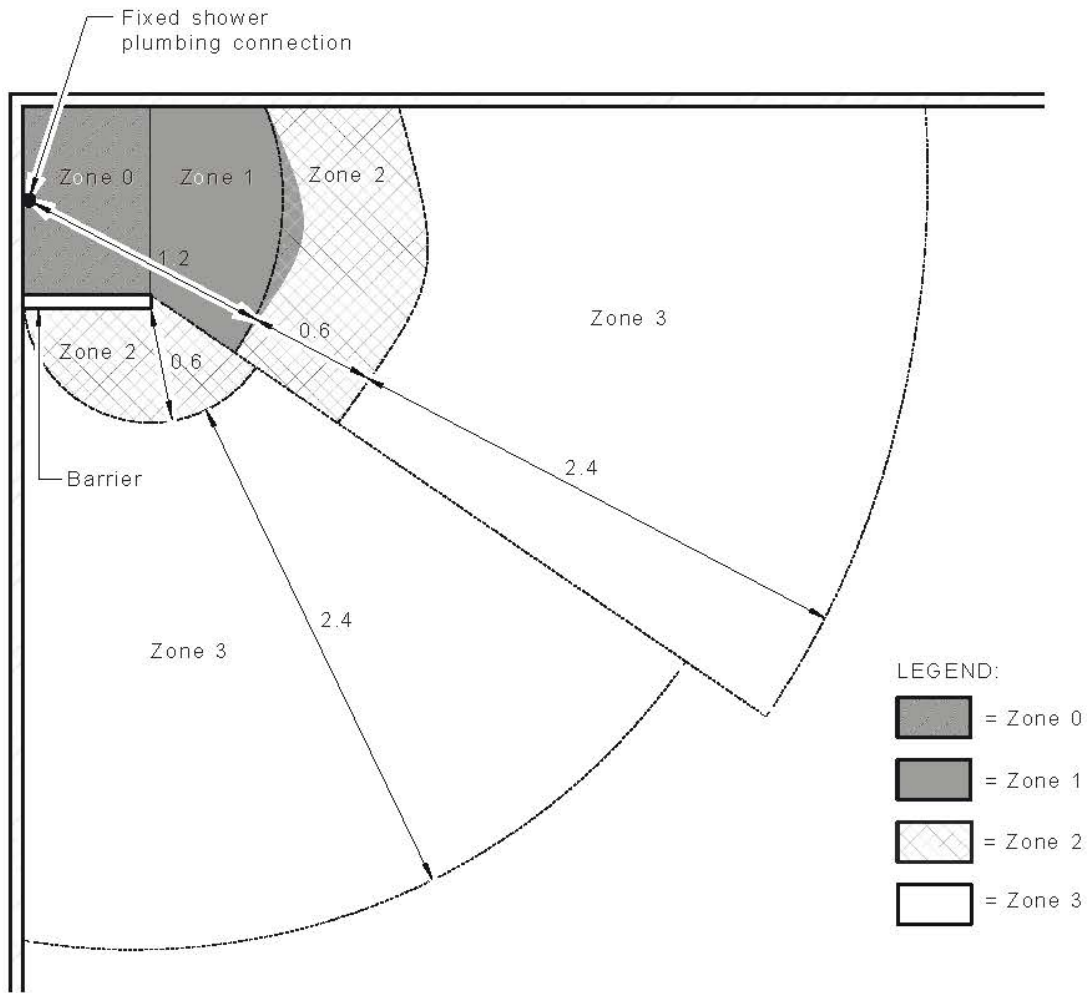

DIMENSIONS IN METRES

FIGURE 6.12 ZONE DIMENSIONS (PLAN)—PARTIALLY ENCLOSED SHOWER WITH FIXED PLUMBING CONNECTION ON WALL

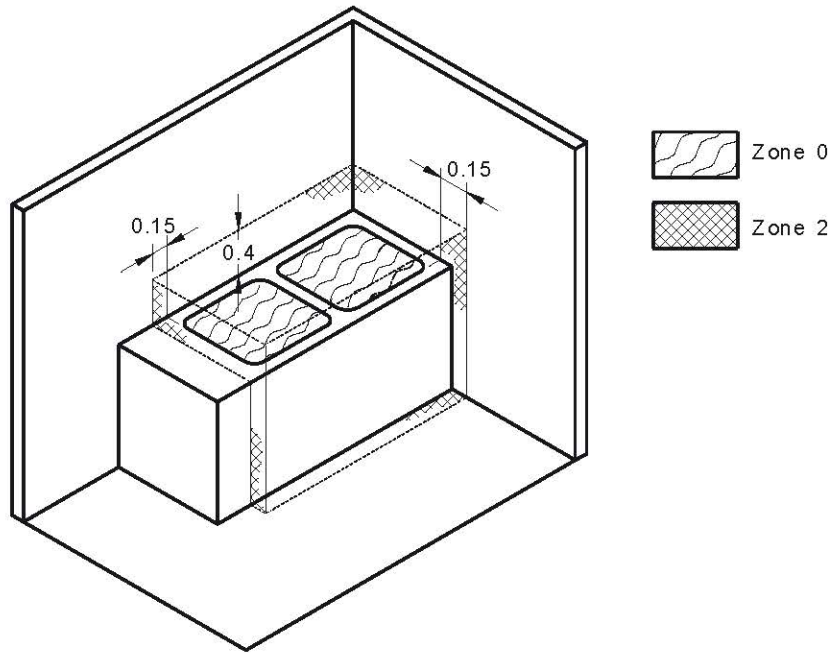

DIMENSIONS IN METRES

- * FIGURE 6.13 ZONE DIMENSIONS FOR OTHER FIXED WATER CONTAINERS WITH FIXED WATER OUTLETS WHERE NO CONTAINER HAS A CAPACITY EXCEEDING 40 L

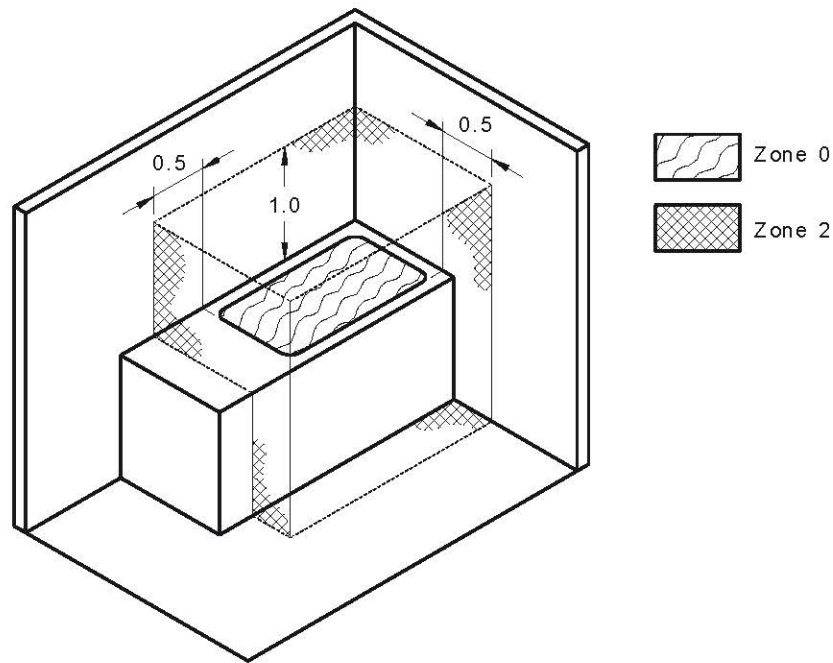

DIMENSIONS IN METRES

- * FIGURE 6.14 ZONE DIMENSIONS FOR OTHER FIXED WATER CONTAINERS WITH A FLEXIBLE WATER OUTLET OR WITH A CAPACITY EXCEEDING 40 L

6.3 SWIMMING POOLS, PADDLING POOLS AND SPA POOLS OR TUBS

6.3.1 Scope

The particular requirements of this Clause (Clause 6.3) apply to electrical installations in locations containing swimming pools, paddling (wading) pools and spa pools or tubs and their surrounding zones, where the risk of electric shock is increased by a reduction in body resistance and the likelihood of contact of the body with the water and conductive structure(s) in contact with the general mass of earth.

NOTE: For swimming pools for medical or large commercial use, special requirements may be necessary.

These requirements are based on the classification of zones surrounding the water container.

Ceilings, walls with or without windows, doors, floors, barriers and fixed partitions (e.g. a 1.8 m solid fence) that limit the extent of a room or area containing a swimming pool, paddling pool, spa pool or tub, and fixed partitions that provide effective protection against spraying or splashing water, limit the associated zones.

Due to the nature of these locations, certain methods of protection against electric shock are not permitted. Refer to Clause 6.3.3.1.

The requirements for swimming pools also apply to electrical installations in areas of natural waters, lakes in gravel pits and coastal and similar areas, especially those intended to be occupied by persons for swimming, paddling and similar purposes.

6.3.2 Classification of zones

6.3.2.1 *Swimming pools and paddling pools*

Three zones (Zones 0, 1 and 2) are classified for swimming pools and paddling pools:

- (a) Zone 0 shall be the area of the interior of the water container of a swimming pool or paddling pool.
- (b) Zone 1 shall be the area limited by the following:
 - (i) Zone 0.
 - (ii) A vertical plane 2.0 m from the internal rim of the water container.
 - (iii) The floor or surface expected to be occupied by persons.
 - (iv) The horizontal plane 2.50 m above the floor or the surface.
 - (v) When the pool contains a diving board, springboard, starting block or a slide, by—
 - (A) the vertical plane situated 1.50 m around the diving board, springboard, starting block or slide; and
 - (B) the horizontal plane 2.50 m above the highest surface expected to be occupied by persons.
- (c) Zone 2 shall be the area limited by—
 - (i) the vertical plane limiting Zone 1 and the parallel vertical plane 1.50 m external to Zone 1; and
 - (ii) the floor, or surface expected to be occupied by persons, and the horizontal plane 2.50 m above the floor or surface.

Examples of these zones are shown in Figures 6.15 and 6.16.

6.3.2.2 *Spa pools or tubs*

6.3.2.2.1 *General*

- * Spa pools or tubs with a water capacity not exceeding 680 L shall comply with the requirements of Clause 6.2.

A spa pool that is attached to a swimming or paddling pool shall be considered to be an extension to the swimming or paddling pool.

NOTE: Electrical equipment installed behind a fixed panel that provides a degree of protection not less than IPX4, and to which access may only be gained by the use of a tool, would not be considered to be in a classified zone.

6.3.2.2.2 *Water capacity exceeding 5000 L*

Three zones (Zones 0, 1 and 2) are classified for spa pools or tubs with a capacity exceeding 5000 L, as set out in Clause 6.3.2.1.

6.3.2.2.3 *Water capacity not exceeding 5000 L*

Two zones (Zones 0 and 1) are classified for spa pools and tubs with a capacity exceeding 680 L and up to and including 5000 L, as set out below:

- (a) Zone 0 shall be the area of the interior of the water container.
- (b) Zone 1 shall be the area limited by—
 - (i) the vertical plane 1.25 m from the internal rim of the water container; and
 - (ii) the floor, or the surface expected to be occupied by persons, and the horizontal plane 2.50 m above the floor or surface.

Examples of these zones are given in Figures 6.17 to 6.19.

6.3.3 Protection against electric shock

6.3.3.1 *Prohibited measures*

The following measures of protection against electric shock are prohibited and shall not be used:

- (a) Protection by means of obstacles, in accordance with Clause 1.5.4.5.
- (b) Protection by placing out of reach, in accordance with Clause 1.5.4.6.

6.3.3.2 *Supplementary equipotential bonding*

Where electrical equipment situated in a classified zone is required to be earthed, all extraneous conductive parts in Zones 0, 1 and 2 shall be connected together by equipotential bonding conductors and connected to the protective earthing conductor of the electrical equipment, in accordance with Clause 5.6.2.6.

6.3.3.3 *Voltage gradients*

Where electrical equipment is in contact with pool or tub water, failure of insulation may result in a hazardous voltage appearing across or through the water. A very low voltage is sufficient to present a hazard to persons immersed in the water.

Protective measures for such equipment shall include—

- (a) use of RCDs with a fixed rated residual current not exceeding 30 mA to protect circuits supplying Class I (earthed conductive parts) equipment; or
- (b) electrical separation, in accordance with Clauses 1.5.5.5 and 7.4.

6.3.4 Selection and installation of electrical equipment

6.3.4.1 Degree of protection required

Electrical equipment permitted to be installed in a classified zone shall have at least the following degree of protection:

- (a) In Zone 0—IPX8.
- (b) In Zone 1—IPX5.
- (c) In Zone 2—IPX4.

The requirements for selection and installation of electrical equipment are provided in Table 6.2.

6.3.4.2 Wiring systems

Wiring systems shall be installed so as to prevent—

- (a) entry of moisture to any connection; and
- (b) water siphoning through any wiring enclosure or cable.

Bare aerial conductors shall not be installed over Zones 0, 1 or 2.

Other types of aerial cables shall be installed in accordance with Clause 3.12.

6.3.4.3 Socket-outlets

Socket-outlets shall not be installed within 0.3 m of any floor or any other horizontal surface in any location where the floor or surface is likely to become wet.

Regardless of the degree of protection provided by the equipment, the following requirements apply to the installation of socket-outlets in classified zones:

- (a) *Zone 0* Socket-outlets shall not be installed in Zone 0.
- (b) *Zone 1* Socket-outlets not necessary for the connection of pool equipment shall not be installed in Zone 1.

Socket-outlets necessary for the connection of pool equipment shall be as follows:

- (i) Provided with the required degree of protection.
- (ii) Located—
 - (A) at a height not less than 0.45 m above ground level and at a horizontal distance not less than 1.25 m from the internal rim of the water container; or
 - (B) beneath and not less than 0.5 m from the edge of a fixed continuous horizontal barrier that is not less than 1.25 m wide measured from the internal rim of the water container.

- (iii) One of the following:
 - (A) Supplied individually as a separated circuit, in accordance with Clause 7.4.
 - (B) Supplied as an SELV or a PELV system, in accordance with Clause 7.5.
 - (C) Protected by a residual-current device with a fixed rated residual current not exceeding 30 mA.
- (iv) Controlled by a switch that requires manual operation and does not operate automatically by the insertion or withdrawal of a plug.
- (c) *Zone 2* Socket-outlets installed in *Zone 2* shall be provided with the required degree of protection and—
 - (i) supplied individually as a separated circuit, in accordance with Clause 7.4; or
 - (ii) supplied as an SELV or a PELV system, in accordance with Clause 7.5; or
 - (iii) protected by an RCD with a fixed rated residual current not exceeding 30 mA.

6.3.4.4 *Switches and other accessories*

The following requirements apply to the installation of switches and accessories, other than socket-outlets, in classified zones:

- (a) *Zone 0* Switches and other accessories shall not be installed in *Zone 0*.
- (b) *Zone 1 and 2* Switches and other accessories installed in *Zone 1* or *Zone 2* shall be provided with the required degree of protection.

6.3.4.5 *Luminaires, appliances and other electrical equipment*

- * The following requirements apply to the installation of luminaires, appliances and other items of electrical equipment, excluding those specified in Clauses 6.3.4.3 (Socket-outlets) and 6.3.4.4 (Switches and other accessories), in classified zones:

- (a) *Zone 0* Luminaires, appliances and other electrical equipment installed in *Zone 0* shall be—
 - (i) designed and constructed specifically for use in a swimming or spa pool; and
 - (ii) provided with the required degree of protection.

Each luminaire, appliance or other item of electrical equipment shall be supplied—

- (A) from an individual source installed outside *Zone 0*;

NOTE: An individual source may be an individual isolation transformer or an individual winding on an isolation transformer having a number of secondary windings, provided that the output complies with Clause 7.5.3.

- (B) at a nominal voltage not exceeding 12 V a.c. or 30 V ripple-free d.c.; and
- (C) as an SELV or a PELV system, in accordance with Clause 7.5.

Luminaires installed in Zone 0 shall not be provided with a protective earthing conductor. Refer to Clause 5.4.3.

- (b) *Zone 1* Luminaires, appliances and other electrical equipment installed in Zone 1 shall be provided with the required degree of protection and—
 - (i) supplied as an SELV or a PELV system, in accordance with Clause 7.5; or
 - (ii) of Class II construction (double or reinforced insulation) and fixed in position; or
 - (iii) of Class I construction (earthed conductive parts), fixed in position and supplied from a circuit protected by an RCD with a fixed rated residual current not exceeding 30 mA.
- (c) *Zone 2* Luminaires, appliances and other electrical equipment installed in Zone 2 shall be provided with the required degree of protection and—
 - (i) supplied as an SELV or a PELV system, in accordance with Clause 7.5; or
 - (ii) supplied individually as a separated circuit, in accordance with Clause 7.4; or
 - (iii) of Class II construction (double or reinforced insulation); or
 - (iv) of Class I construction (earthed conductive parts) and supplied from a circuit protected by an RCD with a fixed rated residual current not exceeding 30 mA.

NOTES:

- 1 Heating cable systems in Zones 1 and 2 intended for heating the location and that are embedded in the floor and protected in accordance with Clause 4.10 may be installed.
- 2 The use of a purpose made pump and installation to the manufacturer's instructions complying with the requirements of AS/NZS 60335.2.41 for each zone is deemed to comply with the requirements of this Clause.

6.3.4.6 *Switchboards*

A switchboard shall not be installed within any classified zone.

6.3.4.7 *Electricity generation systems*

- * Electricity generation systems, including engine-driven generator sets, stand-alone power systems, grid-connected inverter systems and battery systems shall not be installed within any classified zone.

6.3.4.8 *Electricity distributor's electrical equipment*

- * Pools and spas shall not be located in areas containing electrical equipment, including connection pits and cabinets, owned by the electricity distributor, that result in such equipment being incorporated into any classified zone.

TABLE 6.2
SELECTION AND INSTALLATION OF ELECTRICAL EQUIPMENT
FOR SWIMMING POOLS, PADDLING POOLS AND SPA POOLS
OR TUBS

Equipment	Zone 0	Zone 1	Zone 2
Clause 6.3.4.3— Socket-outlets	Not permitted	Not permitted for general use For pool equipment only: (a) IPX5. (b) (i) ≥ 0.45 m high; and ≥ 1.25 m from internal rim; or (ii) under and ≥ 0.5 m from edge of fixed continuous horizontal barrier ≥ 1.25 m wide. (c) (i) separated supply; (ii) SELV or PELV supply; or (iii) RCD protection.	IPX4 and— (a) separated supply; (b) SELV or PELV supply; or (c) RCD protection.
Clause 6.3.4.4— Switches/accessories	Not permitted	IPX5	IPX4
Clause 6.3.4.5(a), (b) and (c)—Luminaires, appliances and other equipment	IPX8; and specifically for use; and 12 V a.c./30 V d.c. SELV or PELV supply from source outside zone No earth	IPX5 and— (a) SELV or PELV supply; (b) Class II construction (double or reinforced insulation); or (c) Class I construction (earthed conductive parts), fixed in position and RCD protection.	IPX4 and— (a) SELV or PELV supply; (b) separated supply; (c) Class II construction (double or reinforced insulation); or (d) Class I construction (earthed conductive parts), and RCD protection.
Clause 6.3.4.5(d)— Heating cable systems	Not applicable	Permitted where embedded in the floor area under the zone and protected to Clause 4.10.5	As for Zone 1

(continued)

TABLE 6.2 (continued)

Equipment	Zone 0	Zone 1	Zone 2
Clause 6.3.4.6— Switchboards	Not permitted	Not permitted	Not permitted
* Clause 6.3.4.7— Electricity generation systems	Not permitted	Not permitted	Not permitted
* Clause 6.3.4.8— Electricity distributor's electrical equipment	Not permitted	Not permitted	Not permitted

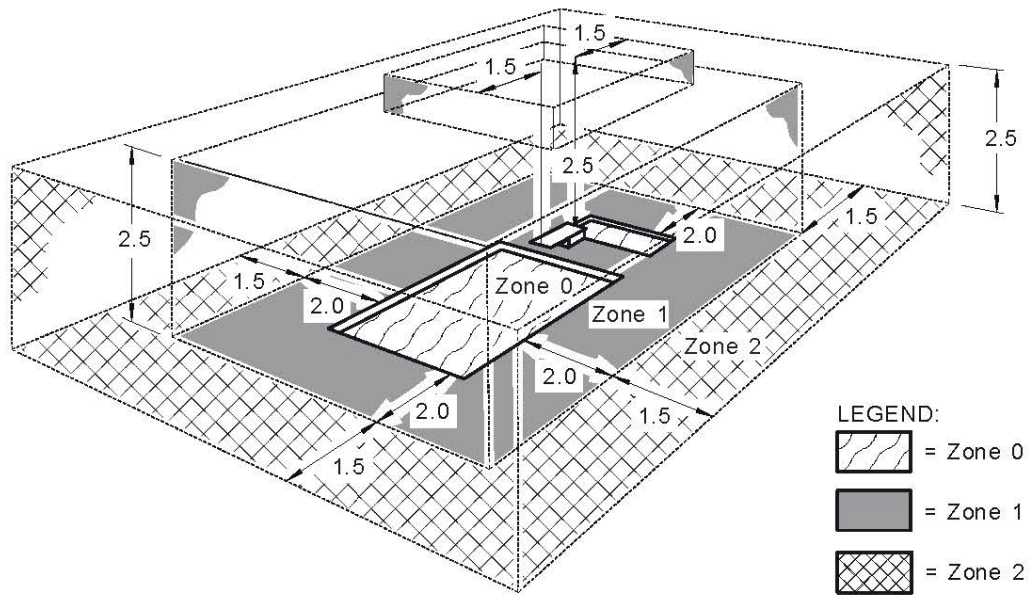

DIMENSIONS IN METRES

FIGURE 6.15 ZONE DIMENSIONS OF IN-GROUND SWIMMING POOLS

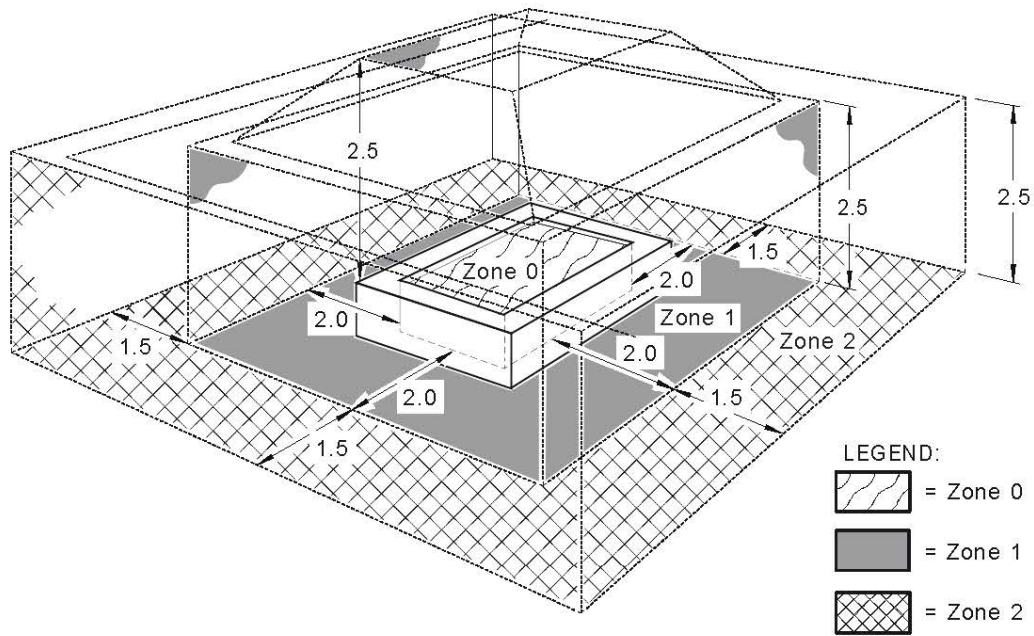

DIMENSIONS IN METRES

FIGURE 6.16 ZONE DIMENSIONS OF ABOVE-GROUND SWIMMING POOLS

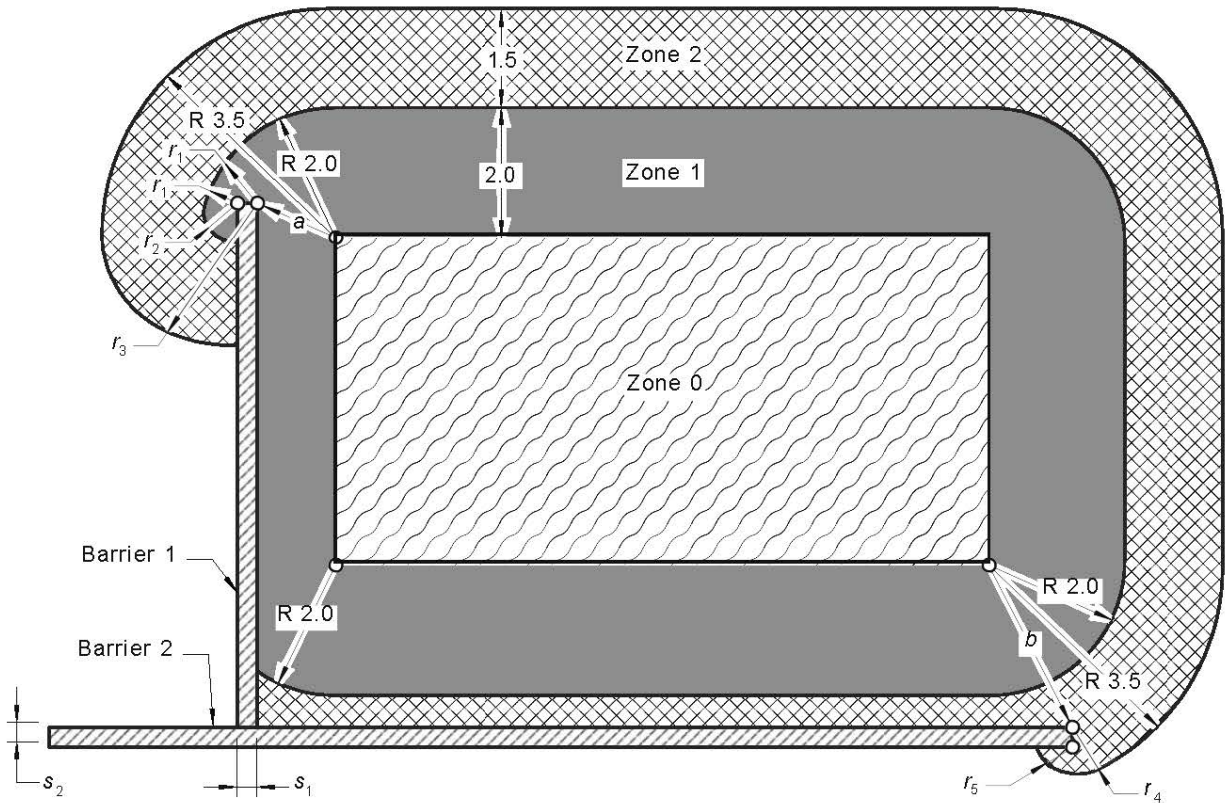

LEGEND:

- $r_1 = 2.0 - a$
 - $s_1 = \text{Width of barrier 1}$
 - $r_2 = r_1 - s_1$
 - $s_2 = \text{Width of barrier 2}$
 - $r_3 = 3.5 - a$
 - $r_4 = 3.5 - b$
 - $r_5 = r_4 - s_2$
- = Zone 0
 - = Zone 1
 - = Zone 2

NOTE: These dimensions apply to swimming pools, paddling pools and wading pools.

DIMENSIONS IN METRES

FIGURE 6.17 ZONE DIMENSIONS OF SWIMMING POOLS WITH FIXED BARRIERS (MINIMUM 1.8 m HIGH)

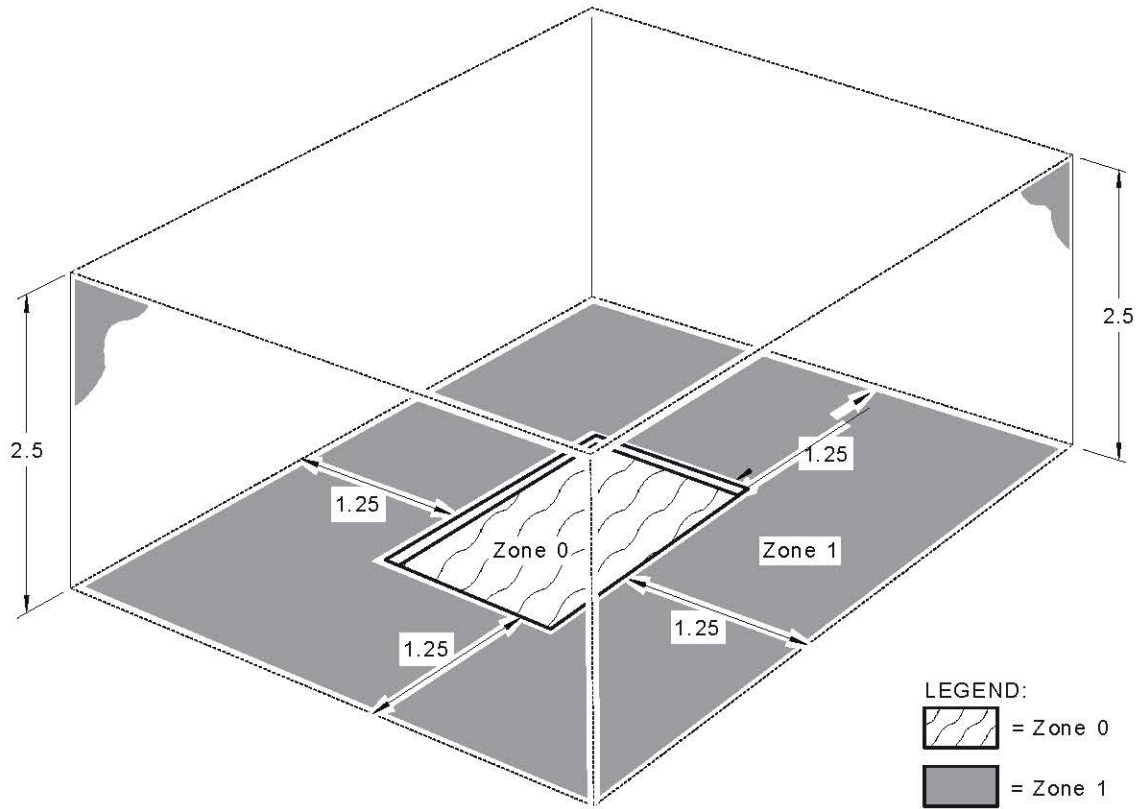

DIMENSIONS IN METRES

FIGURE 6.18 ZONE DIMENSIONS OF IN-GROUND SPA POOLS AND TUBS WITH WATER CAPACITY NOT EXCEEDING 5000 L

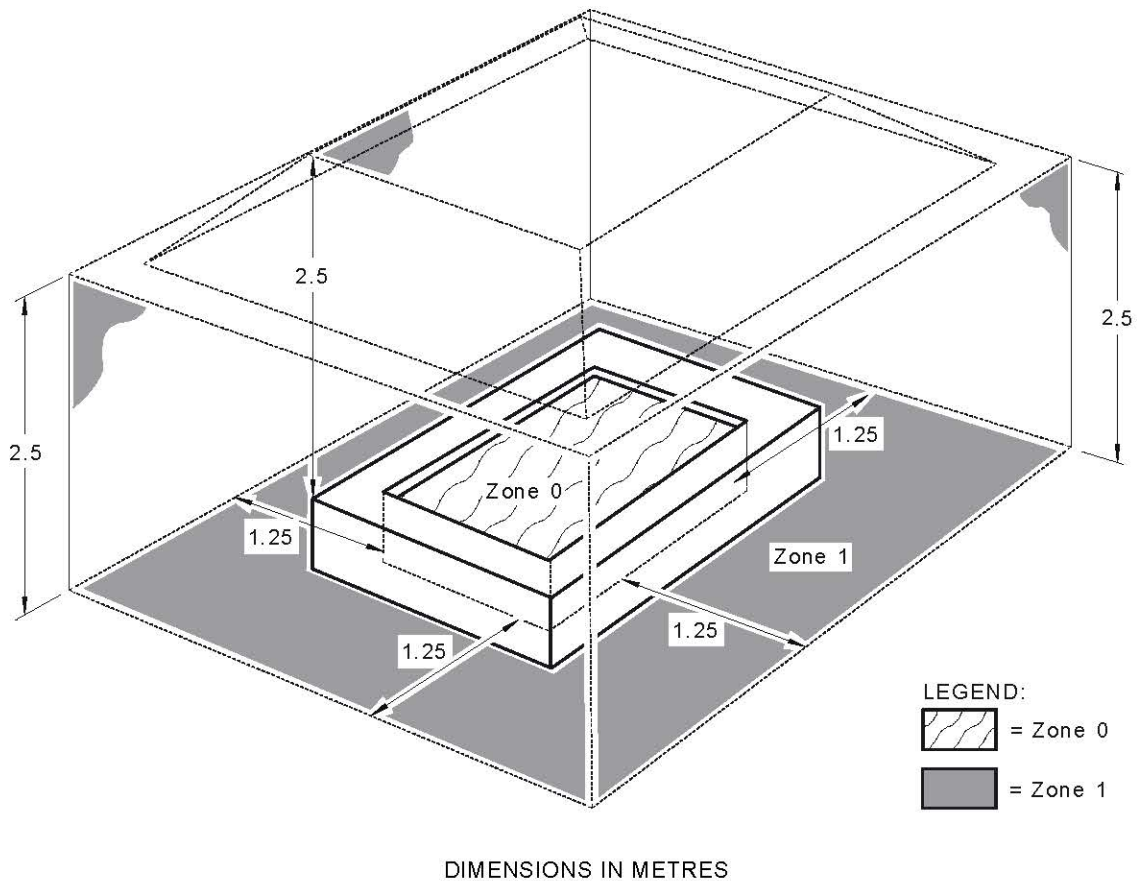

FIGURE 6.19 ZONE DIMENSIONS OF ABOVE-GROUND SPA POOLS
AND TUBS WITH WATER CAPACITY NOT EXCEEDING 5000 L

6.4 FOUNTAINS AND WATER FEATURES

6.4.1 Scope

The particular requirements of this Clause (Clause 6.4) apply to the electrical installations associated with water containers of fountains and water features and their surrounding zones where the risk of electric shock is increased by a reduction in body with the water and conductive structure(s) in contact with the general mass of earth.

These requirements are based on the classification of zones surrounding the water container associated with the fountain or water feature and are intended to—

- (a) protect electrical material and electrical equipment from the corrosive effects of chemicals used in the treatment of water in fountains and water features; and
- (b) counter the increased risks of using electrical equipment in areas where the body may be partially immersed in water.

Exception:

These requirements need not apply to fountains or water features where—

- (a) the depth of water does not exceed 0.3 m; or*
- (b) suitable means are provided to restrict entry of persons to the water.*

Ceilings, walls with or without windows, doors and floors that limit the extent of a room or area containing a fountain or water feature and fixed partitions that provide effective protection against spraying or splashing water, limit the associated zones.

Due to the nature of these locations, certain methods of protection against electric shock are not permitted. Refer to Clause 6.4.3.2.2.

6.4.2 Classification of zones

Two zones (Zones 0 and 1) are classified for fountains and water features:

- (a) Zone 0 shall be the area of the interior of the water containers including any recesses in their walls or floors or the interior of water jets or waterfalls.
- (b) Zone 1 shall be the area limited by the following:
 - (i) The vertical plane 2.0 m from the internal rim of the water containers.
 - (ii) The floor, or surface expected to be occupied by persons, and the horizontal plane 2.50 m above the floor or surface.
 - (iii) When the fountain or water feature contains sculptures and decorative water containers, by—
 - (A) the vertical plane situated 1.50 m around the sculptures and decorative water containers; and
 - (B) the horizontal plane 2.50 m above the sculptures and decorative water containers.

Examples of these zones are shown in Figures 6.20 and 6.21.

6.4.3 Protection against electric shock

6.4.3.1 Use of SELV

Where SELV is used, regardless of the nominal voltage, basic protection shall be provided in accordance with Clause 7.5.5.

6.4.3.2 Application of protective measures against electric shock

6.4.3.2.1 Supply

Electrical equipment shall be—

- (a) earthed and protected by an RCD with a fixed rated residual current not exceeding 30 mA;

- (b) supplied at either extra-low voltage or low voltage through an isolating transformer complying with AS/NZS 61558, and not earthed; or
- (c) supplied by other suitable measures that take account of the electrical equipment construction, installation methods and physical location.

6.4.3.2.2 Prohibited measures

The following measures of protection against electric shock are prohibited and shall not be used:

- (a) Protection by means of obstacles, in accordance with Clause 1.5.4.5.
- (b) Protection by placing out of reach, in accordance with Clause 1.5.4.6.

6.4.4 Selection and installation of electrical equipment

6.4.4.1 Degree of protection required

Electrical equipment permitted to be installed in the classified zone shall have at least the following degree of protection:

- (a) In Zone 0—IPX8.
- (b) In Zone 1—IPX5.

The requirements for selection and installation of electrical equipment are provided in Table 6.3.

6.4.4.2 Wiring systems

Wiring systems for a fountain or water feature shall be—

- (a) elastomer or thermoplastic insulated and sheathed copper cables or flexible cords suitable for immersion in the type of water being used;
- (b) where subject to mechanical damage, installed in a wiring enclosure; and
- (c) installed so as to prevent—
 - (i) entry of moisture to any connection; and
 - (ii) water siphoning through any wiring enclosure or cable.

6.4.4.3 Socket-outlets

Socket-outlets shall not be installed in Zone 0 or Zone 1.

6.4.4.4 Switches and other accessories

The following requirements apply to the installation of switches and accessories, other than socket-outlets, in classified zones:

- (a) *Zone 0* Switches and other accessories shall not be installed in Zone 0.
- (b) *Zone 1* Switches and other accessories installed in Zone 1 shall be provided with the required degree of protection.

6.4.4.5 *Luminaires, appliances and other electrical equipment*

The following requirements apply to the installation of luminaires, appliances and other electrical equipment in classified zones:

- (a) *Zone 0* Luminaires, appliances and other electrical equipment shall be—
- (i) designed and constructed specifically for use in a fountain or water feature;
 - (ii) provided with the required degree of protection; and
 - (iii) each luminaire, appliance or other item of electrical equipment shall be supplied—
 - (A) from an individual source installed outside Zone 0;

NOTE: An individual source may be an individual isolation transformer or an individual winding on an isolation transformer having a number of secondary windings, provided that the output complies with Clause 7.5.3.
 - (B) at a nominal voltage not exceeding 12 V a.c. or 30 V ripple-free d.c.; and
 - (C) as an SELV or a PELV system, in accordance with Clause 7.5.

Luminaires installed in Zone 0 shall not be provided with a protective earthing conductor. Refer to Clause 5.4.3.

- (b) *Zone 1* Luminaires, appliances and other electrical equipment installed in Zone 1 shall be provided with the required degree of protection and—
- (i) supplied as an SELV or a PELV system, in accordance with Clause 7.5; or
 - (ii) of Class II construction (double or reinforced insulation) and fixed in position; or
 - (iii) of Class I construction (earthed conductive parts), fixed in position and supplied from a circuit protected by an RCD with a fixed rated residual current not exceeding 30 mA.

NOTE: The use of a purpose made pump and installation to the manufacturer's instructions complying with the requirements of AS/NZS 60335.2.41 for each zone is deemed to comply with the requirements of this Clause.

6.4.4.6 *Switchboards*

A switchboard shall not be installed within any classified zone.

* 6.4.4.7 *Electricity generation systems*

Electricity generation systems, including engine-driven generator sets, stand-alone power systems, grid-connected inverter systems and battery systems, shall not be installed within any classified zone.

* **6.4.4.8 Electricity distributor's electrical equipment**

Fountains and water features shall not be located in areas containing electrical equipment, including connection pits and cabinets, owned by the electricity distributor, that result in such equipment being incorporated into any classified zone.

*

TABLE 6.3

**SELECTION AND INSTALLATION OF ELECTRICAL EQUIPMENT
FOR FOUNTAINS AND WATER FEATURES**

Equipment	Zone 0	Zone 1
Clause 6.4.4.3— Socket-outlets	Not permitted	Not permitted
Clause 6.4.4.4— Switches/accessories	Not permitted	Shall be provided with the required degree of protection
Clause 6.4.4.5— Luminaires, appliances and other equipment	(a) Designed and constructed specifically for use in a fountain or water feature. (b) Provided with the required degree of protection. (c) Supplied— (i) from an individual source installed outside Zone 0; (ii) at a nominal voltage not exceeding 12 V a.c. or 30 V ripple free d.c.; and (ii) as an SELV or a PELV system. Luminaires shall not be provided with a protective earth.	Shall be provided with the required degree of protection and— (a) supplied as an SELV or a PELV system; (b) of Class II construction (double or reinforced insulation) and fixed in position; or (c) of Class I construction (earthed conductive parts), fixed in position and supplied from a circuit protected by an RCD with a fixed rated residual current not exceeding 30 mA.
Clause 6.4.4.6— Switchboards	Not permitted	Not permitted
* Clause 6.4.4.7— Electricity generation systems	Not permitted	Not permitted
* Clause 6.4.4.8— Electricity distributor's electrical equipment	Not permitted	Not permitted

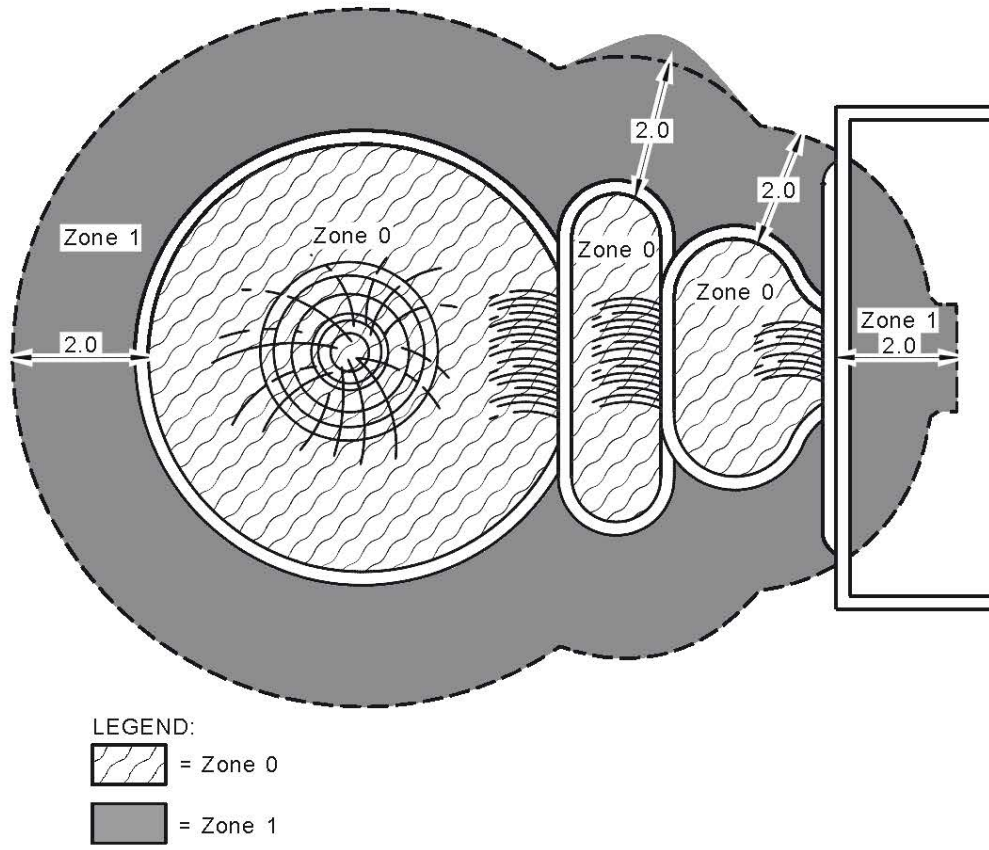

DIMENSIONS IN METRES

FIGURE 6.20 EXAMPLE FOR DETERMINATION OF THE ZONES OF A FOUNTAIN (PLAN)

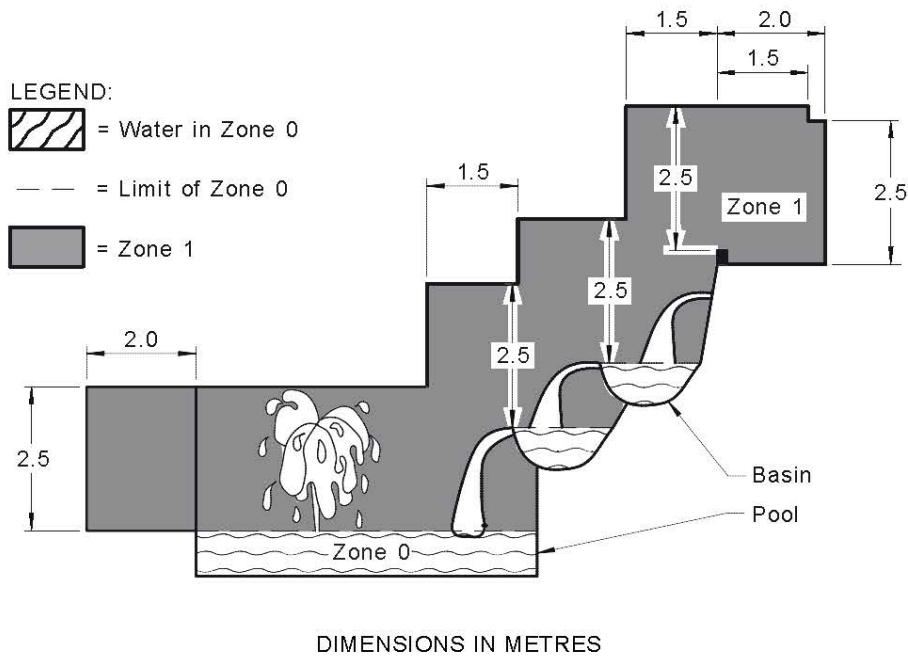

FIGURE 6.21 EXAMPLE FOR DETERMINATION OF THE ZONES OF A FOUNTAIN (ELEVATION)

6.5 SAUNAS

6.5.1 Scope

The particular requirements of this Clause (Clause 6.5) apply to electrical installations in rooms or enclosures containing heating equipment used exclusively for sauna heating.

These requirements are based on the classification of zones surrounding the sauna heater.

* Due to the nature of these locations, certain methods of protection against electric shock are not permitted. Refer to Clause 6.5.3.2.

6.5.2 Classification of zones

Three zones (Zones 1, 2 and 3) are classified for locations containing a sauna heater:

- (a) Zone 1 shall be the area containing the sauna heater limited by—
 - (i) the vertical plane 0.5 m from the external edge of the sauna heater; and
 - (ii) the floor, or surface expected to be occupied by persons, and the cold side of the thermal insulation of the ceiling.

- (b) Zone 2 shall be the area limited by—
 - (i) the vertical plane limiting Zone 1 and the cold side of the thermal insulation of the walls of the sauna room or enclosure; and
 - (ii) the floor, or surface expected to be occupied by persons, and the horizontal plane 1.0 m above the floor.
- (c) Zone 3 shall be the area limited by—
 - (i) the vertical plane limiting Zone 1 and the cold side of the thermal insulation of the walls of the sauna room or enclosure; and
 - (ii) the horizontal plane 1.0 m above the floor and the cold side of the thermal insulation of the ceiling.

NOTE: Zone 3 is directly above Zone 2. Examples of these zones are given in Figure 6.22.

6.5.3 Protection against electric shock

6.5.3.1 Use of SELV

Where SELV is used, regardless of the nominal voltage, basic protection shall be provided in accordance with Clause 7.5.5.

6.5.3.2 Prohibited measures

The following measures of protection against electric shock are prohibited and shall not be used:

- (a) Protection by means of obstacles, in accordance with Clause 1.5.4.5.
- (b) Protection by placing out of reach, in accordance with Clause 1.5.4.6.

6.5.3.3 Additional protection by RCD

All equipment within the sauna room, other than the sauna heater, shall be provided with additional protection by an RCD with a fixed rated residual current not exceeding 30 mA.

6.5.4 Selection and installation of electrical equipment

6.5.4.1 Degree of protection required

Electrical equipment installed within the sauna room shall have a degree of protection of at least IPX4B or IP24.

6.5.4.2 Requirements in classified zones

The installation of electrical equipment and wiring in classified zones shall be in accordance with the following:

- (a) *Zone 1* Only electrical equipment belonging to the sauna heater shall be installed in Zone 1.
- (b) *Zone 2* There are no special requirements concerning heat resistance of electrical equipment for Zone 2.

- (c) *Zone 3* Electrical equipment shall be suitable to withstand a minimum temperature of 125°C and the insulation of conductors shall be suitable to withstand a minimum temperature of 170°C.

6.5.4.3 *Wiring systems*

Wiring systems should be installed outside the zones, i.e. on the cold side of the thermal insulation.

If the wiring system is installed in Zone 1 or 3, i.e. on the warm side of the thermal insulation, it shall be heat-resistant, in accordance with Clause 6.5.4.2(c). Metallic sheaths and metallic conduits shall not be accessible in normal use.

NOTE: Examples of suitable wiring systems are insulated, unsheathed cables in non-metallic enclosures or sheathed cables.

6.5.4.4 *Socket-outlets, switches and other accessories*

Socket-outlets, switches and other accessories shall not be installed within a sauna room or enclosure.

Exception: Switches and other accessories that form part of the sauna heater may be located within the sauna room or enclosure.

6.5.4.5 *Sauna heating appliances*

Sauna heating appliances shall be installed in accordance with the manufacturer's instructions.

6.5.4.6 *Switchboards*

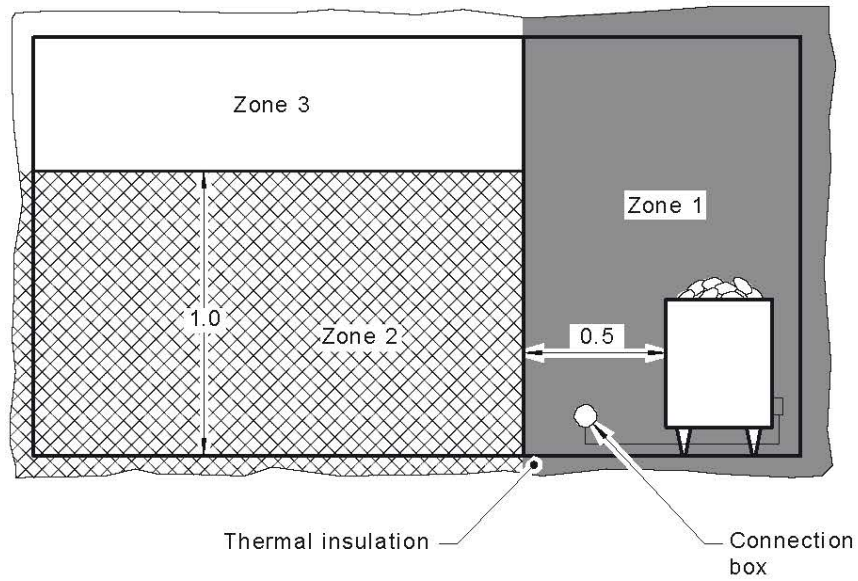

A switchboard shall not be installed within any classified zone.

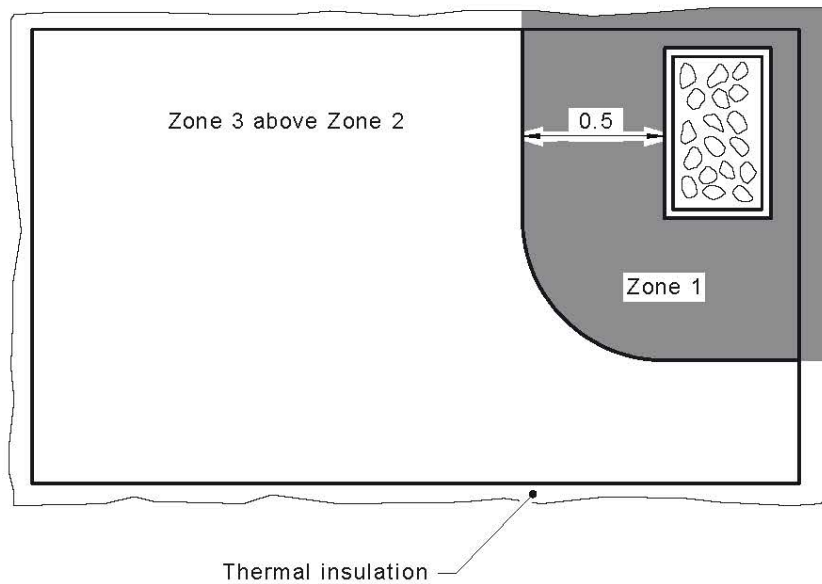

(a) Elevation



(b) Plan

- LEGEND:
-  = Zone 1
 -  = Zone 2
 -  = Zone 3

DIMENSIONS IN METRES

FIGURE 6.22 CLASSIFIED ZONES FOR SAUNA HEATERS

6.6 REFRIGERATION ROOMS

6.6.1 Scope

The particular requirements of this Clause (Clause 6.6) apply to all of the area within refrigeration rooms, such as, freezers or cold rooms.

Due to the nature of these locations, certain methods of protection against electric shock are not permitted. Refer to Clause 6.6.2.2.

6.6.2 Protection against electric shock

6.6.2.1 Use of SELV

Where SELV is used, whatever the nominal voltage, basic protection shall be provided in accordance with Clause 7.5.5.

6.6.2.2 Prohibited measures

The following measures of protection against electric shock are prohibited and shall not be used:

- (a) Protection by means of obstacles, in accordance with Clause 1.5.4.5.
- (b) Protection by placing out of reach, in accordance with Clause 1.5.4.6.

6.6.3 Selection and installation of electrical equipment

6.6.3.1 Degree of protection required

Electrical equipment permitted to be installed within the refrigeration room shall have a degree of protection of at least IPX4B or IP24.

NOTE: See also Clause 6.7 regarding areas that are subjected to a sanitization or hosing-down process.

6.6.3.2 Wiring systems

6.6.3.2.1 General

The wiring system used for the supply, control and protection of electrical equipment within a refrigeration room shall be of a type that—

- (a) will not be affected by the operating temperature of the room; and
- (b) does not provide pockets or channels in which moisture might accumulate, or through which it might pass into electrical equipment.

Wiring systems not associated with the refrigeration room electrical equipment shall not be taken through, or be installed, in such rooms.

6.6.3.2.2 Types permitted

The following wiring systems are permitted:

- (a) Unenclosed sheathed cables including served MIMS cables.
- (b) Insulated, unsheathed or sheathed cables enclosed in a wiring enclosure that has adequate draining facilities.

- (c) Other wiring systems that are not inferior to the systems described in Item (a) or Item (b).

NOTE: PVC insulated, unsheathed or sheathed cables may not be satisfactory for electrical installations in refrigerated rooms where the cables may be subjected to bending, flexing or vibration at temperatures below approximately 0°C. See Clause 3.3.2.1 and Table 3.2.

6.6.3.2.3 Sealing

The following shall be sealed with a compound that does not set hard:

- (a) Each wiring enclosure at any point where it passes from a refrigerated to a non-refrigerated space.
- (b) The point of entry of cables into motors, luminaires, switches or other electrical equipment.

6.6.3.3 Socket-outlets, switches and other accessories

Socket-outlets, switches and other accessories shall be designed such that provision is made to prevent the retention of moisture within their enclosure.

This requirement may be satisfied by the use of socket-outlets, switches and other accessories, and controlgear having the required degree of protection, in accordance with Clause 6.6.4.1, or Clause 6.7, as appropriate, that are permanently sealed.

6.6.3.4 Luminaires, lampholders and other equipment

6.6.3.4.1 Luminaires

Luminaires shall be permanently sealed to prevent the entry of liquid or vapour, or shall be designed and constructed so that—

- (a) moisture cannot enter the lampholder and other components containing live parts; and
- (b) provision is made to prevent the retention of moisture in or on the fitting.

6.6.3.4.2 Lampholders

Lampholders shall comply with the following:

- (a) *Construction* Lampholders shall be—
- (i) the all-insulated type; or
 - (ii) any other suitable type that precludes the possibility of any external metal portion becoming live.
- (b) *Location* Lampholders shall not be suspended within 2.50 m of the floor or ground when on a flexible pendant.

6.6.3.5 Fixed appliances and motors

Fixed appliances shall be designed and constructed for the particular location and conditions.

Electrical equipment enclosures shall have, or provide, a degree of protection suitable for the conditions in which the electrical equipment is installed.

This requirement is deemed to be satisfied by the provision of internal heaters in the appliance or enclosure that would prevent the retention of moisture.

6.6.3.6 Heating elements in door seals

Heating elements in refrigeration room door seals shall be provided with additional protection by an RCD with a fixed rated residual current not exceeding 30 mA.

6.6.3.7 Switchboards

A switchboard shall not be installed in a refrigeration room.

6.7 SANITIZATION AND GENERAL HOSING-DOWN OPERATIONS

6.7.1 Scope

The particular requirements of this Clause (Clause 6.7) apply to electrical installations where sanitization or general hosing-down operations are carried out.

Due to the nature of these locations, certain methods of protection against electric shock are not permitted. Refer to Clause 6.7.3.2.

NOTE: Electrical installations where the requirements of this Clause may apply include food production or processing areas and agricultural or horticultural premises, such as rooms, locations or areas where—

- (a) livestock are kept;
- (b) feed, fertilizers, vegetable or animal products are produced stored, prepared or processed;
- (c) plants are grown, such as greenhouses or hydroponic installations;
- (d) agricultural or horticultural products are produced, prepared or processed, e.g. dairies, and facilities for drying, stewing, pressing out, fermenting, butchering, meat processing, etc.; or
- (e) car wash bays and the like are provided.

6.7.2 Classification of zone

The classified zone is based on the dimensions and limits of any location likely to be affected by hosing, as follows:

- (a) Where the area is to be sanitized or hosed down throughout, the classified zone consists of the whole of the space between the floor, walls and ceiling, including any recess therein, enclosing the area.
- (b) Where hosing-down is limited to the floor and walls, the classified zone consists of—
 - (i) any location within the space from the floor, or the base of a recess in the floor, to a horizontal plane 2.0 m above the floor;

- (ii) any wall within the area; and
 - (iii) any location on a ceiling that is within 1.0 m of a wall within the area.
- (c) Where hosing-down is limited to the floor only, the classified zone consists of any location within the space from the floor, or the base of a recess in the floor, to a horizontal plane 1.0 m above the floor.

6.7.3 Protection against electric shock

6.7.3.1 Use of SELV

Where SELV is used, whatever the nominal voltage, basic protection shall be provided in accordance with Clause 7.5.5.

6.7.3.2 Prohibited measures

The following measures of protection against electric shock are prohibited and shall not be used:

- (a) Protection by means of obstacles, in accordance with Clause 1.5.4.5.
- (b) Protection by placing out of reach, in accordance with Clause 1.5.4.6.

6.7.4 Selection and installation of electrical equipment

6.7.4.1 Degree of protection required

Electrical equipment installed within the classified zone shall have a degree of protection of at least—

- (a) IPX5 where low or medium pressure hosing-down is used; and
- (b) IPX6 where high pressure hosing is used.

6.7.4.2 Electrical equipment

Electrical equipment, including the wiring system, used in the classified zone shall be of a type that—

- (a) will not be affected by the method of hosing, materials used, temperature and pressure of the hosing medium;
- (b) is protected against moisture that might accumulate; and
- (c) does not provide channels or pockets through which moisture might pass into electrical equipment.

6.7.4.3 Switchboards

Switchboards installed in classified zones in locations subject to sanitization or hosing-down operations shall be provided with a minimum degree of protection of IPX6.