

**UEE62220 Advanced Diploma in Electrical Engineering+**  
**UEE62122 Advanced Diploma in Engineering Technology (Electrical)**  
**Exercises**

Prepared by

**U Kyaw Naing (Joe)**

BE(EP), MSc(EE), MIEAust, RPEQ(Electrical), Postgrad Dip Sc Ed (Curtin University-WA)

MSc(Science Education)(Curtin University –WA) ,Grad Dip Adult & Vocational Ed (TAFE-NSW),

Certificate IV TAA (TAA40104 +TAE40110), Registered Teacher (Western Australian College of Teaching),

Certificate of Proficiency (Electrical Fitter-NSW VTT), Certificate III in Electrical Wiring (TAFE-NSW),

NSW Electrician Licence, Craft Certificate (Electronic-Computer System) (NSW VTT)

No	EE011 Units	EE020 Units UEE62220+UEE62122	Page
1	UEENEEE011C+E017C	UEECD0026 + UEECD0024	2
2	UEENEEE125A Part 1	UEECD0036	5
3	UEENEEE127A	UEECD0049	18
4	(UEENEEG160A+G161A) Part 1		30
5	UEENEEE126A Part 1	UEECD0039	39
6	UEENEEE071B	UEECD0059	65
7	Electrical Workshop UEENEEE101A+E102A+E104A +E105A+E107A+E108A+E137A	UEECD0007+ UEECD0019+ UEECD0044+ UEECD0046+ UEECD0020+UEECD0016+UEECD0051	72
8	UEENEEG101A+G102A	UEEEL0021+UEEEL0019+UEEEL0020	82
9	UEENEEG106A+G033A+G063A	UEEEL0023+UEEEL0008+UEEEL0009+UEEEL0010+ UEEEL0003	92
10	UEENEEG103A+G104A	UEEEL0012	100
11	UEENEEG107A	UEEEL0018	104
12	UEENEEG130A Part 2	UEEEL0038	109
13	UEENEEG076A+G127A+G128A+G177A+G130A(1) +UETTDRIS68A+DRIS74A+	UETDRIS033	115
14	UETTDRIS73A+UEENEEG006A Part 1	UEEEL0024+UEEEL0025	132
15	UETTDRIS71A	UETDRIS027	143
16	UEENEEG143A+G145A+I145A	UEEEL0043+UEEEL0041+UEEIC0016	152
17	UEENEEG144A+I146A+ (UEENEEG160A+G161A) Part 2	UEEEL0019+UEEIC0017	168
18	UEENEEE126A Part 2	UEECD0039+UEECD0049	176
19	UEENEEE125A Part 2	UEECD0036	182
20	UEENEEG149A	UEEEL0062	193
21	UEENEEG169A+G170A+E124A	UEEEL0058+UEEEL0015+UEECD0014+UEECO0001+ UEECO0002+UEECO0015+UEECO0017	201
22	UEENEEI124A Part 1	UEECD0010	207
23	UEENEEI129A Part 2	UEEIC0020	208
24	UEENEEI129A Part 3	UEEIC0020	212
25	UEENEEI148A+I129A Part 1	UEEIC0040+UEEIC0042	218
26	UEENEEI149A+I129A Part 1	UEEIC0040+UEEIC0042	229
27	UEENEEI124A Part 2		233
28	UEENEEI120A+I123A	UEEIC0028+UEEIC0006	240
29	UEENEEK125A	UEERE0060+UEERE0061	254
30	UEENEEK135A		259
31	UEENEEK151A	UEERE0066	263
32	Work Performance Practicals and Projects		275

**Exercises for slides**

E011+E017

**(1) Hazard of electricity +risk assessment**

Slide 1

Q1.What are the hazards of electricity

Slide 2

Q2.How can electricity impact on human's body?

Q3.What are the effects of electricity passing through the body?

Slide 3

Q4.How can you classify Extra Low Voltage & Low Voltage

Slide 4

Q5.How will you manage the risk?

Slide 5+6

Q6.What are the risk of danger given by the improperly maintained electrical equipment?

Slide 7

Q7.Write down the electrical equipments maintenance plan.

---

**(2) Risk analysis**

Slide 1

Q8.What are the risks?

Q9.How are the risks classified?

Q10.How can the risk be evaluated?

Slide 2

Q11.How will you manage the risk?

Slide 3

Q12.Write down the risk reduction procedures in maintenance work.

**(3) Low Voltage Safety**

Slide 1

Q13. Describe the risks in LV system.

Slide 2

Q14. What are the dangers that can be given by electrical equipments in laboratory?

Slide 3+4

Q15. Describe the risks and dangers in power station and outline the recommended safety equipments and emergency procedures.

Slide 5

Q16. Outline the process of maintenance work in substation.

---

#### **(4) Safety in substation**

Slide 2+3+4+5

Q17. Write down the check list to perform the tasks in substation.

Slide 6+7

Q18. Write down the safety procedures and methods to assess the risk and to reduce the risk.

---

#### **(5) Installation safety**

Slide 3

Q19. Write down the steps in measurement process.

Slide 4+5

Q20. Draw the motor control centre risk assessment table.

---

#### **(6) Working near exposed main**

Slide 1

Q21. Write down the code of practice for working near exposed main and apparatus.

Slide 2+3

Q22. Which precautions are to be emphasized when working in substation?

**E025****Exercises for slides**

Slide 1+2

Q1. Sketch the graph for capacitor charging voltage and inductor charging current

Slide 3

Q2

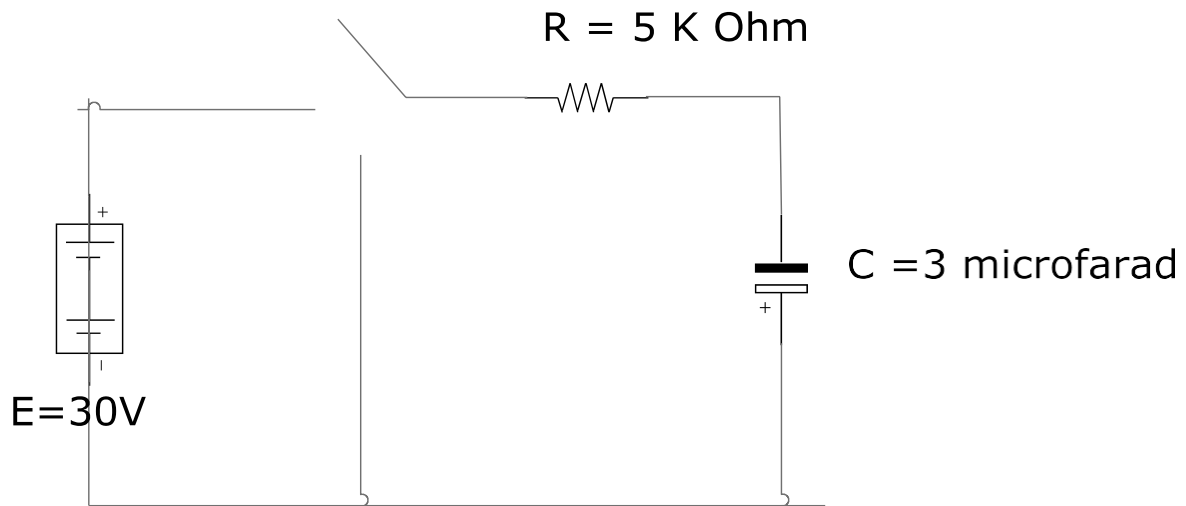
Calculate  $V_c$  and  $I_c$ 

Slide 4

Q3. Write down the formula to calculate the charging time

Slide 5

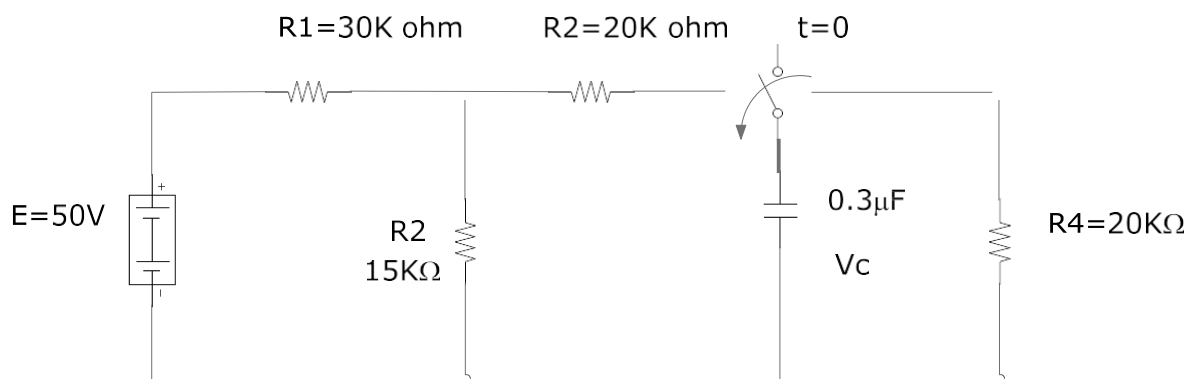
Q4. For the given network, find the mathematical expression for  $V_c$  &  $I_c$ 

Slide 6

Q5. Find the voltage across and charge on each capacitor for the network.

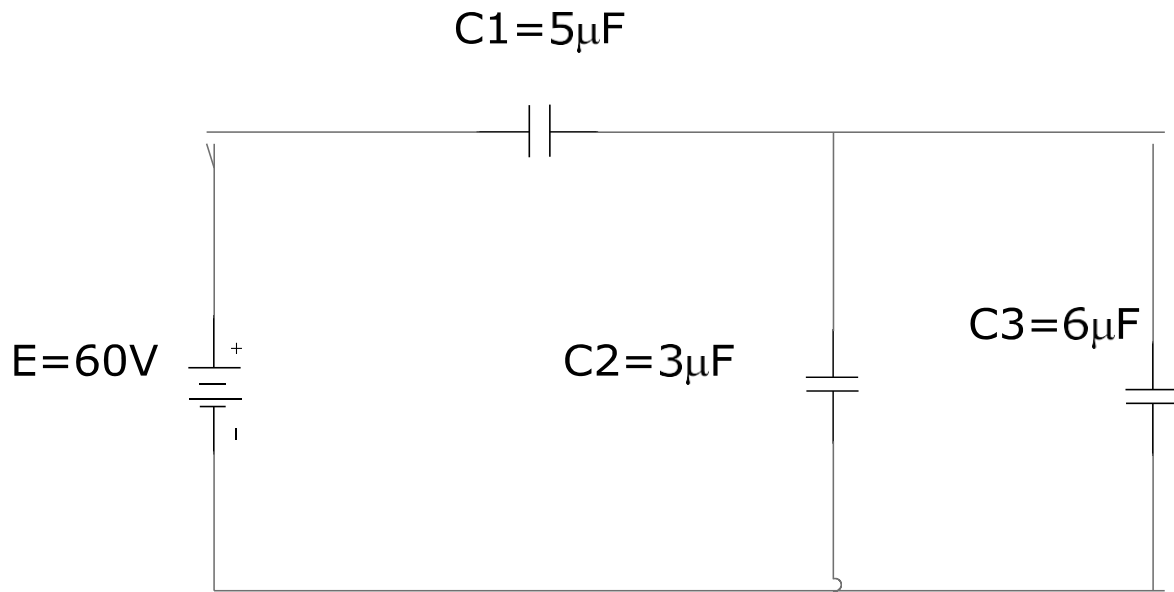

Slide 8

Q6. Find the mathematical expression for the transient current in inductor L

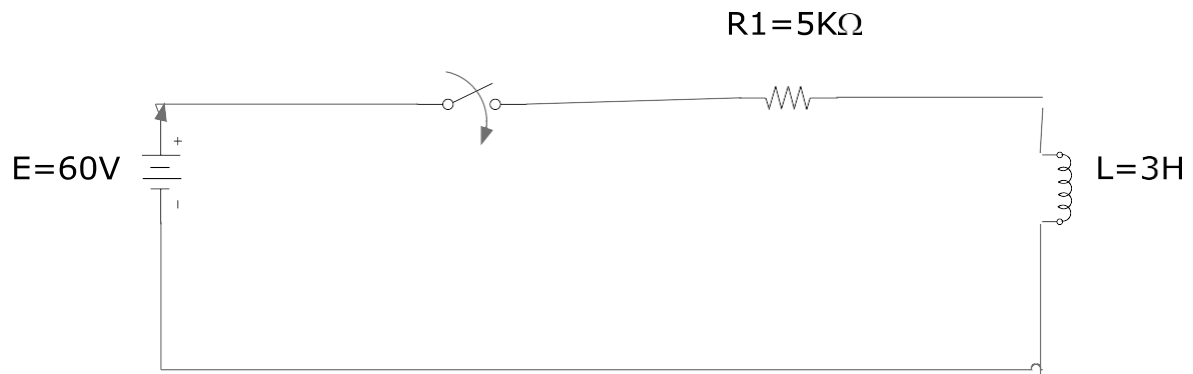

E025/2/Slide 2

Q7. Write down the equation to calculate parallel resonance.

E025/2/Slide 3

Q8. write down the equation for maximum impedance frequency ( $f_m$ ) and quality factor at parallel resonance.

E025/2/Slide 4

Q9. For the given network with  $f_p$  provided.

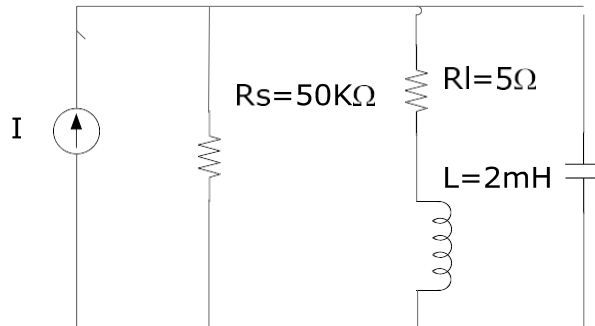

(a) Determine  $Q_l$

(b) Determine  $R_p$

© Calculate  $Z_{tp}$

(d) Find  $C$  at resonance

(e) Find  $Q_p$

(f) Calculate  $BW$

E025/3/Slide 1

Q10. Sketch the graph for

(a) DC (b) Square wave (c) triangular wave (d) Sawtooth wave (e) Rectified dc wave

Q11. Write down the equation for Fourier series.

E025/4/Slide 1

Q12. Sketch the ideal pulse waveform

E025/4/Slide 2

Q13. Sketch the actual pulse waveform

E025/4/Slide 3

Q14. What is base line voltage?

Q15. Write down the equation to calculate % tilt

Q16. Sketch the graph to indicate overshoot.

E025/4/Slide 4

Q17. Determine the followings for the given pulse

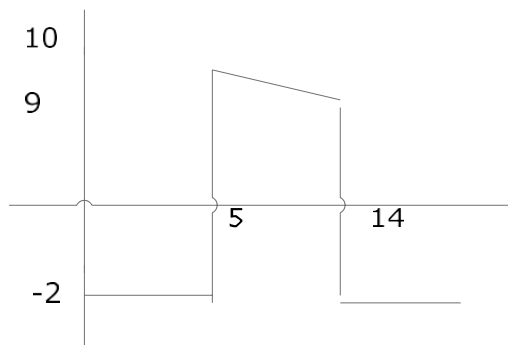

- Positive or negative going
- Base line voltage
- Pulse width
- Maximum amplitude
- Tilt

E025/4/Slide 5

Q18. Write down the equation to calculate the pulse repetition rate and duty cycle.

E025/4/Slide 6

Q19.

Determine the pulse repetition frequency (Prf) and duty cycle for given periodic waveform.

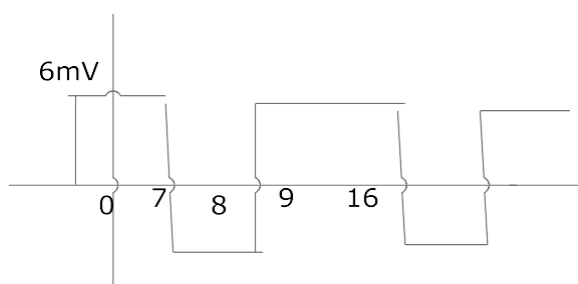

E025/4/Slide 6

Q20. Determine the average value for given periodic pulse waveform.



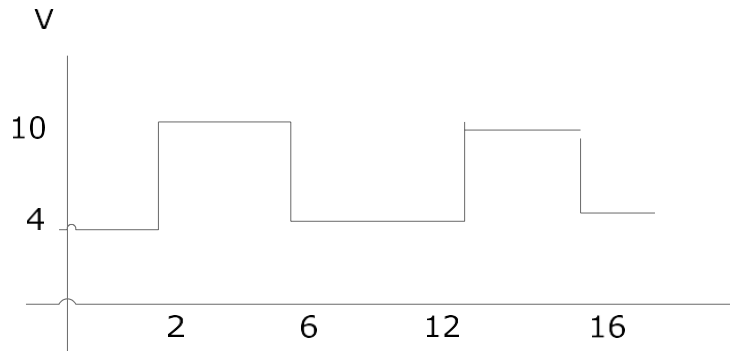

E025/5/Slide 1

Q21. Describe the types of filters.

Q22. Sketch the operation graph of low pass filter.

E025/5/Slide 2

Q23. Sketch the operation graph of high pass filter

Q24. Sketch the operation graph of band pass filter

E025/5/Slide 3

Q25. Sketch the operation graph of band stop filter

Q26. Sketch the equivalent circuit diagram for (a) Low pass filter (b) High pass filter

E025/5/Slide 4

Q27. Sketch the schematic diagram and equivalent circuit diagram for (a) Band pass filter (b) Band stop filter.

E025/5/Slide 5

Q28. Sketch the equivalent circuit diagram for (a) RC filter (b) RL filter and write down the equation to calculate cut-off frequency

E025/5/Slide 6

Q29. Given  $R=30K$  ohm,  $C$  2000 pico farad

(a) Sketch the normalised plot

(b) Determine the magnitude and phase at  $f = \frac{1}{2} F_c$

E025/6/Slide 1

Q30. Write down the formula to calculate the voltage gain of high pass filter.

Q31. Sketch the Bode plot for frequency and voltage gain  $A_v$  in Decibel & phase angle.

E025/6/Slide 2

Q32. Sketch the Bode plot for Low pass RC filter.

E025/7/Slide 1

Q33. Sketch the transformer equivalent circuit and write down the equation to calculate induced voltage, mutual inductance and coupling coefficient.

E025/7/Slide 2

Q34. For the given transformer

- Find mutual inductance ( $M$ )
- Find induced voltage  $E_p$  if the flux changes at the rate of  $500 \text{ m wb/ sec}$
- Find the induced voltage  $E_s$  if the same rate of change indicated in (b)
- Find the induced voltage  $E_p$  and  $E_s$  if the current  $I_p$  changes at rate of  $3 \text{ A/s}$

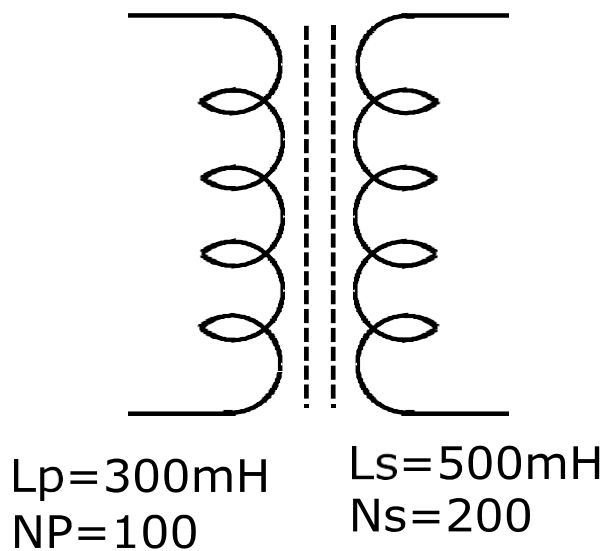

E025/7/Slide 3

Q35. Sketch the connection of mutually coupled coils in same and opposite directions. Write down the equations to calculate total inductance.

E025/7/Slide 4

Q36. Find total inductance of the given series coil.

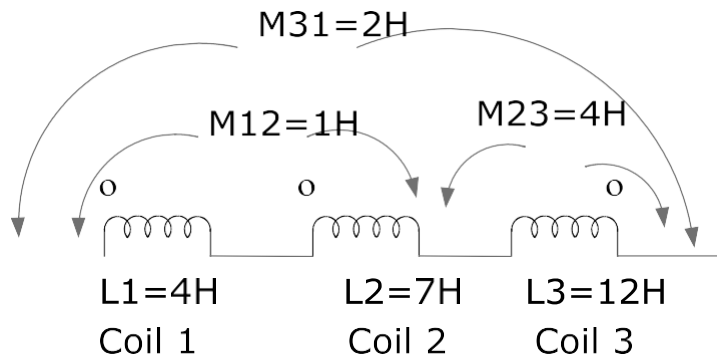

E025/7/Slide 5

Q37. Write down transformer voltage equation

Q38. Write down the equation to calculate the turn ratio of transformer.

Q39. Write down the equation to calculate the secondary resistance referred to primary, secondary inductive reactance referred to primary and secondary voltage referred to primary.

E025/7/Slide 6

Q40. For the transformer given in the figure

- Determine  $R_e$  and  $X_e$
- Determine the magnitude of voltages  $V_I$  and  $V_s$
- Determine the magnitudes of  $V_s$  to establish the same voltage in (b) if  $R_e$  and  $X_e = 0$  ohm.

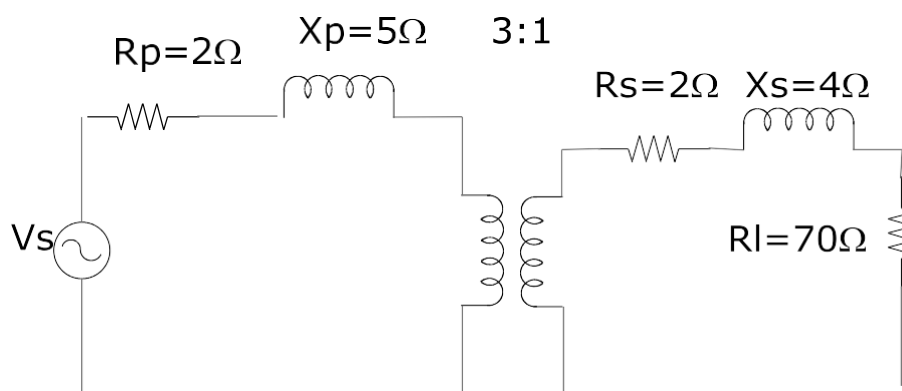

E025/8/Slide 1

Q41. For the given series resonance circuit, find  $I$ ,  $V_r$ ,  $V_I$  and  $V_c$ . If the resonance frequency is 4000Hz, Find the bandwidth. What power dissipated in circuit.

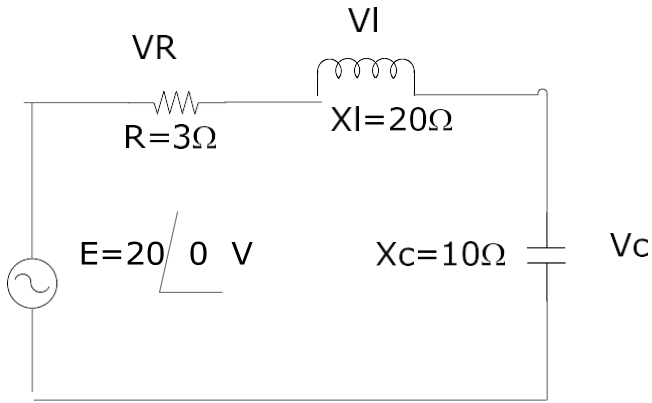

Q42. Write down the equation to calculate the quality factor.

E025/8/Slide 2

Q43. For the given parallel resonance network,

- (a) Determine  $Q_p$
- (b)  $R_p$
- (c)  $Z_{tp}$

Find C at resonance . Find  $Q_p$  and BW

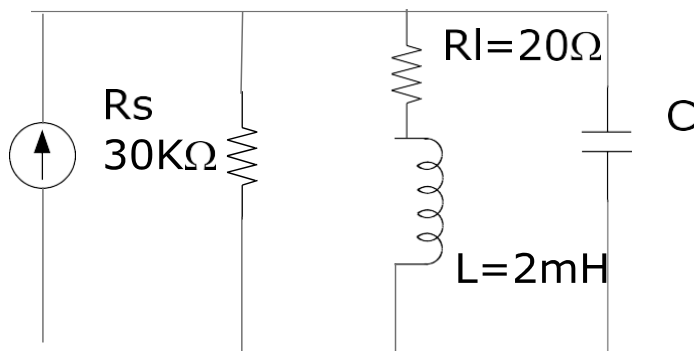

$f_p = 0.05 \text{ mHz}$

E025/8/Slide 3

Q44. Design a parallel resonance circuit to have given graph. Use 20 ohm, 2 mH inductor . Current source has 30 K ohm internal resistance

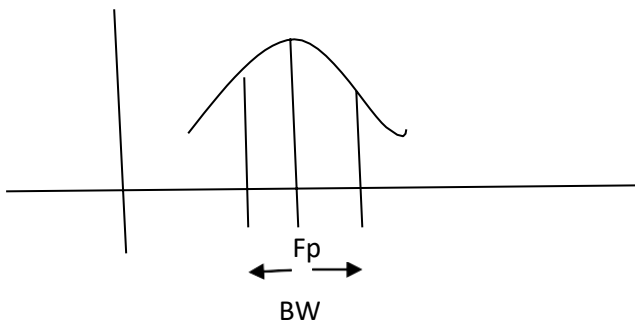

$f_p = 100 \text{ Hz}$

BW=3000HZ

E025/8/Slide 4

Q45. For the given transformer, determine  $R_e$  and  $X_e$ ,  $V_l$  and  $V_s$

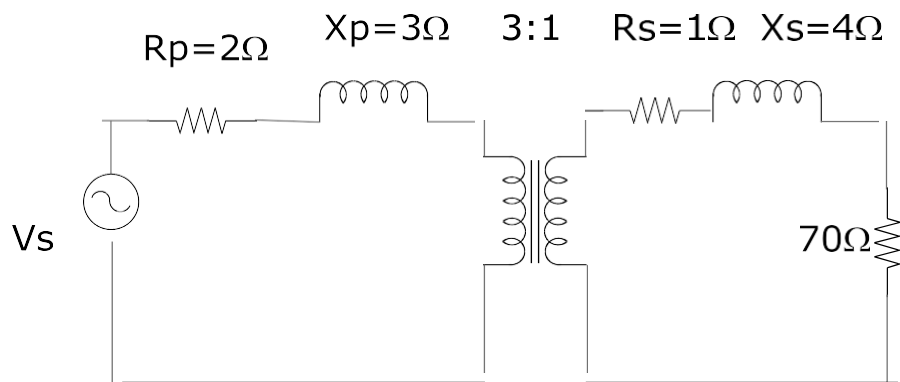

E025/8/Slide 5

Q46. Determine the voltage value of given periodic waveform.

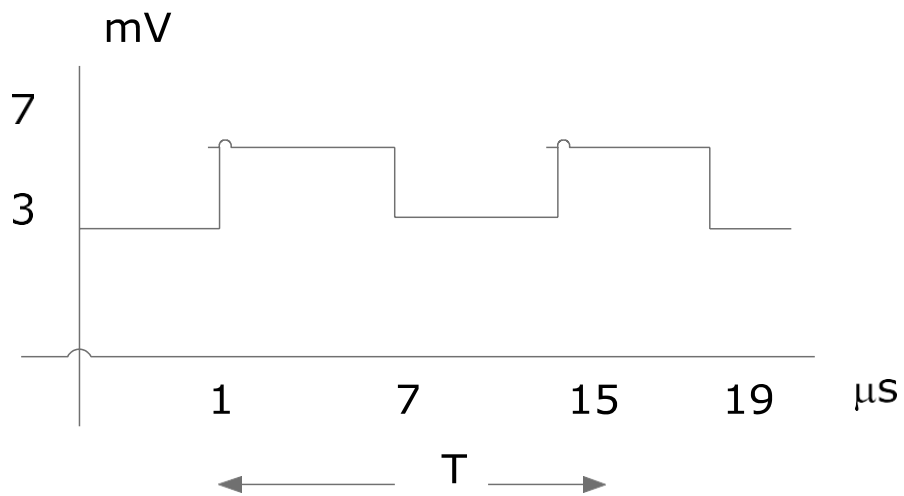

E025/10/Slide 1+2

Q47. Determine the frequency response of impedances, phase angle and current of the following parallel RL network. Calculate resonant frequency.

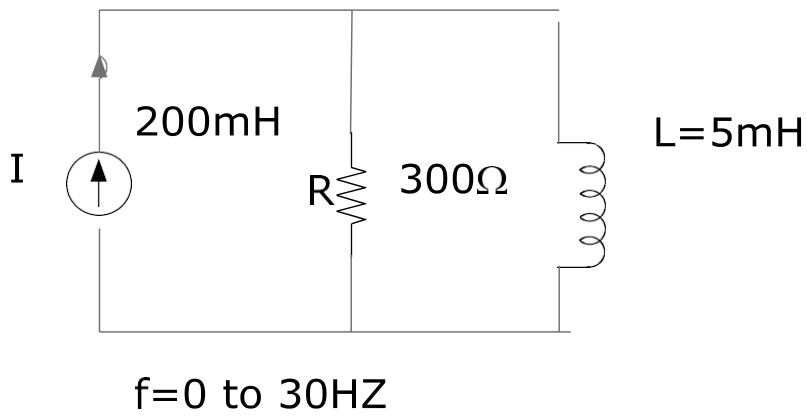

E025/11/Slide 1

Q48. Write down the equation to calculate frequency gain, voltage gain and phase angle for

- (a) low pass filter (b) High pass filter (c) Low pass filter with limited attenuation (d) High pass filter with limited attenuation.

Q49.

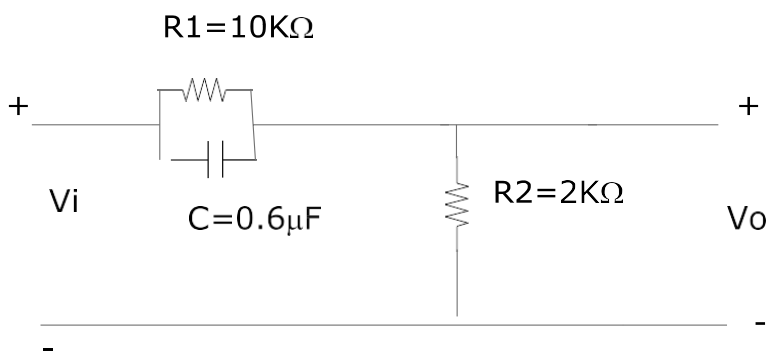

For the above circuit

- (a) Sketch  $A_v$  db VS  $f$  using log scale  
 (b) Sketch  $Q$  vs  $f$  using log scale

The circuit is high pass filter with limited attenuation.

E025/13/Slide 1

Q50.

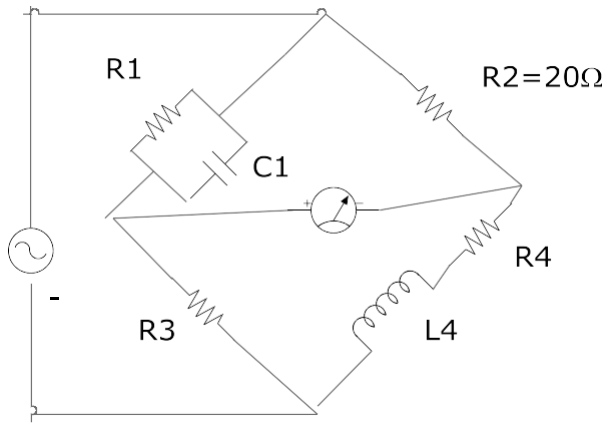

If the above circuit is balanced  $R_1 = 4 \text{ ohm}$ ,  $R_4 = 3 \text{ ohm}$   $X_4 = j 6 \text{ ohm}$  . Find  $X_{c1}$  &  $R_3$

Q51. Sketch the circuit diagram and frequency response of RC circuit and write down the equation.

Q52. Sketch the circuit diagram and frequency response of parallel RL circuit and write down the equation.

E025/14/Slide 1

Q53. Convert delta to star for the given circuit.

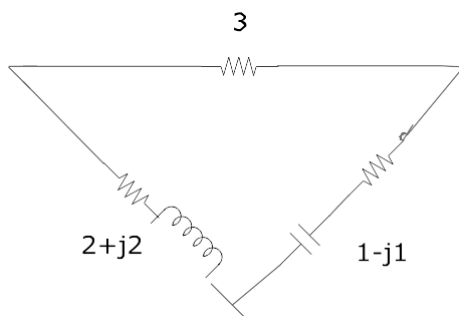

Q54. Convert star to delta for given circuit.

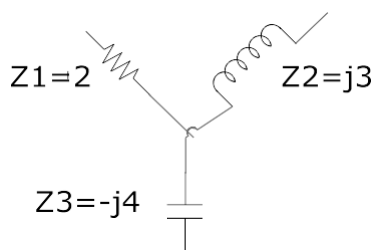

E025/14/Slide 2

Q55. Determine the impedance  $Z$  parameter for the given circuit.

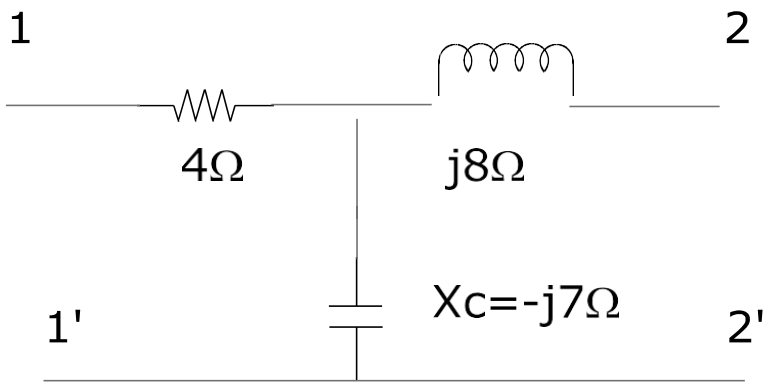

Q56. For the following system employed in the loaded amplifier

- Determine No load voltage gain
- Loaded voltage gain
- Total loaded voltage gain
- $R_o$

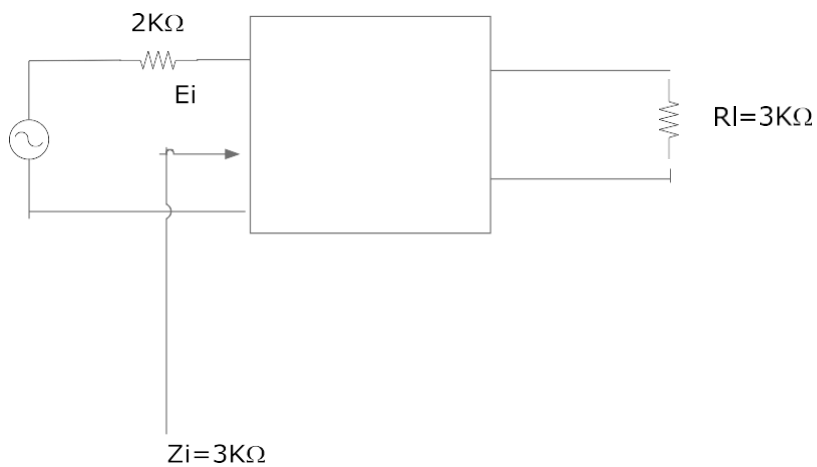
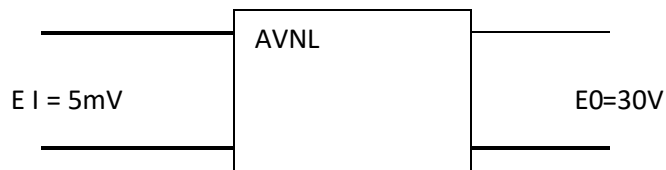

Q57. For the given cascaded system

- Determine the loaded voltage and current gain for each stage
- Calculate total voltage and current gain
- Find total power gain



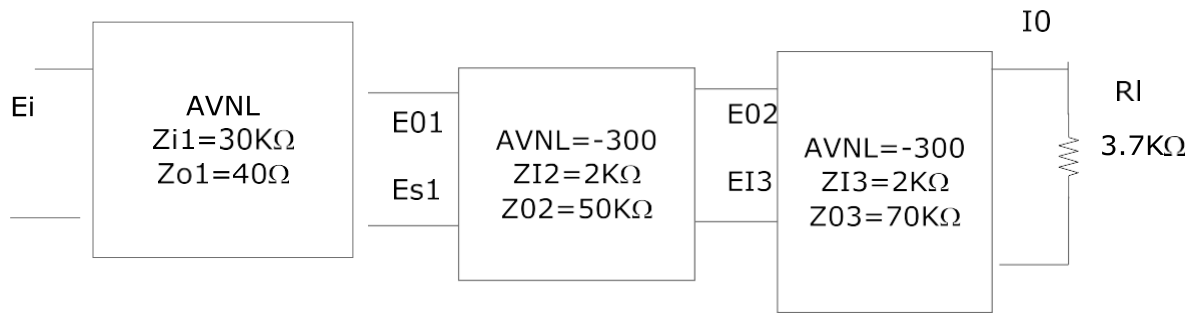

E026

(1) Harmonic and Fourier Analysis

Slide 1

Q1. Sketch the following curves

- (a) Half wave rectifier sine wave
- (b) Square wave
- (c) Exponential wave
- (d) Triangular wave
- (e) Sawtooth wave

Slide 2

Q2. Write the equations for (a) Ninth harmonic (b) Generalized equation for fundamental and harmonic wave.

Slide 3

Q3. Sketch half wave symmetry wave form

Slide 4

Q4. Draw a sample half wave symmetric waveform

Slide 5

Q5. Sketch even symmetry wave

Slide 6

Q6. Sketch odd symmetry wave.

Slide 7+8

Q7. Write the equation for even function and odd function.

Slide 9

Q8. Indicate whether the following series are even or odd

(a)  $f(t) = \frac{2}{\pi} \sin wt + \frac{3}{2\pi} \sin 3wt + \dots$

(b)  $f(t) = 70 \sin \omega t + 20 \sin 2\omega t + 10 \sin 3\omega t + 40 \cos \omega t + 10 \cos 2\omega t$

(c)  $f(t) = 35 - \frac{10}{\pi} \sin \omega t - \frac{10}{2\pi} \sin 2\omega t + \dots$

Slide 10/11

Q9. Construct Fourier series for given wave

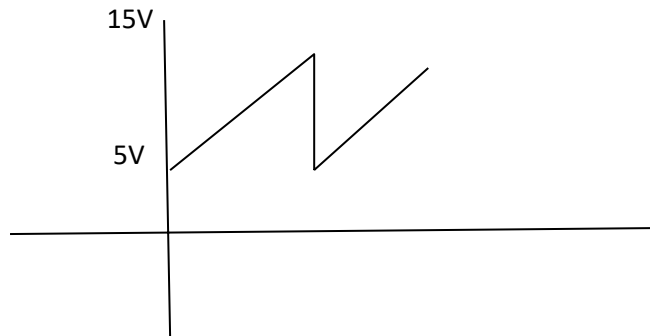

Slide 12+13+14+15

Q10. A series RL circuit has a resistance of  $30 \Omega$  and inductance of  $0.3H$ . The applied voltage is

$$V(t) = 35 + 180 \sin \omega t + 120 \sin 3\omega t \quad \text{where } \omega = 250 \text{ rad/s}$$

Find (a) the instantaneous current (b) RMS value and current (c) Average power supplied to circuit.

---

(2) Calculation of harmonic

Slide 1 to 7

Q11. A wave form has a period  $T = 50ms$ . Calculate the frequencies of fundamental, second, third and fourth harmonics.

Slide 8+9+10

Q12. For each of the following wave form, state the frequencies of the first 3 components.

(a)

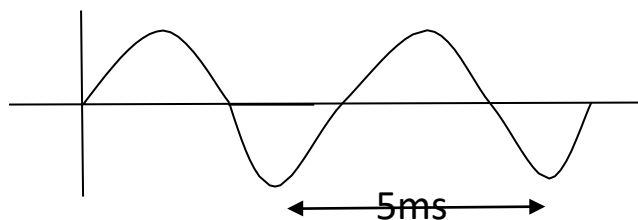

These questions will help you revise what you have learnt in Section 2.

1. For each of the following waveforms, state the frequencies of the first three components present.

(a)

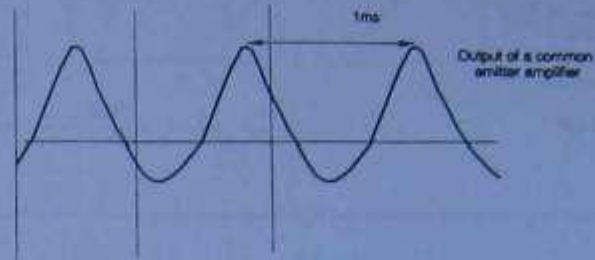

(b)

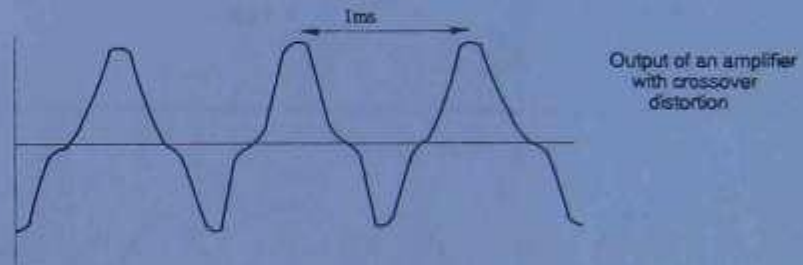

(c)

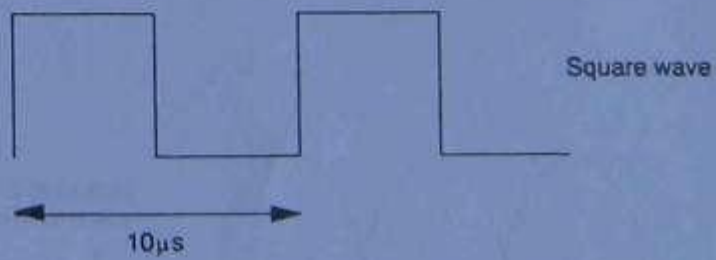

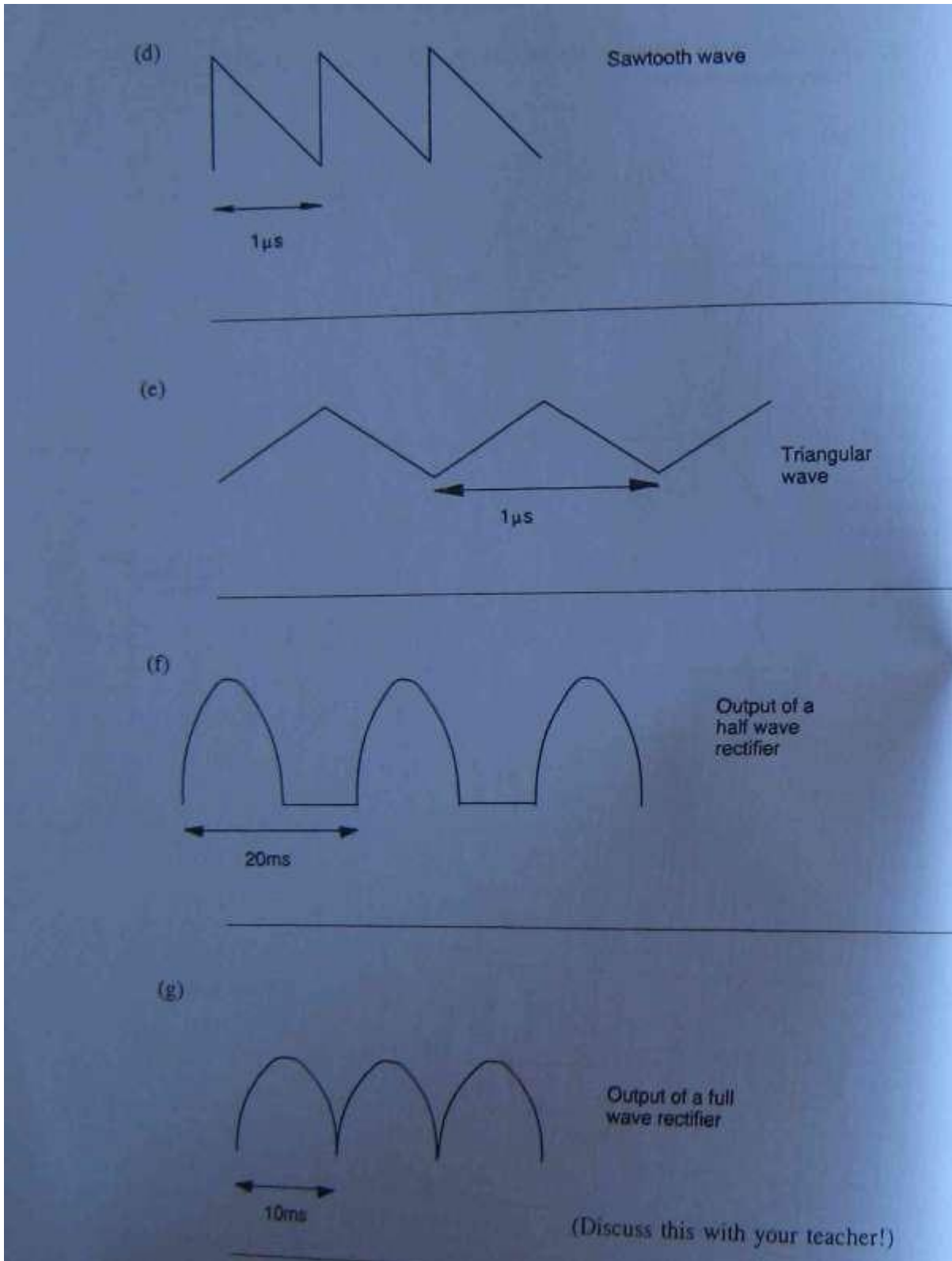

Slide 13, 14 to 20

Q13. Find the first and fourth terms of the given trigonometric wave Fourier series

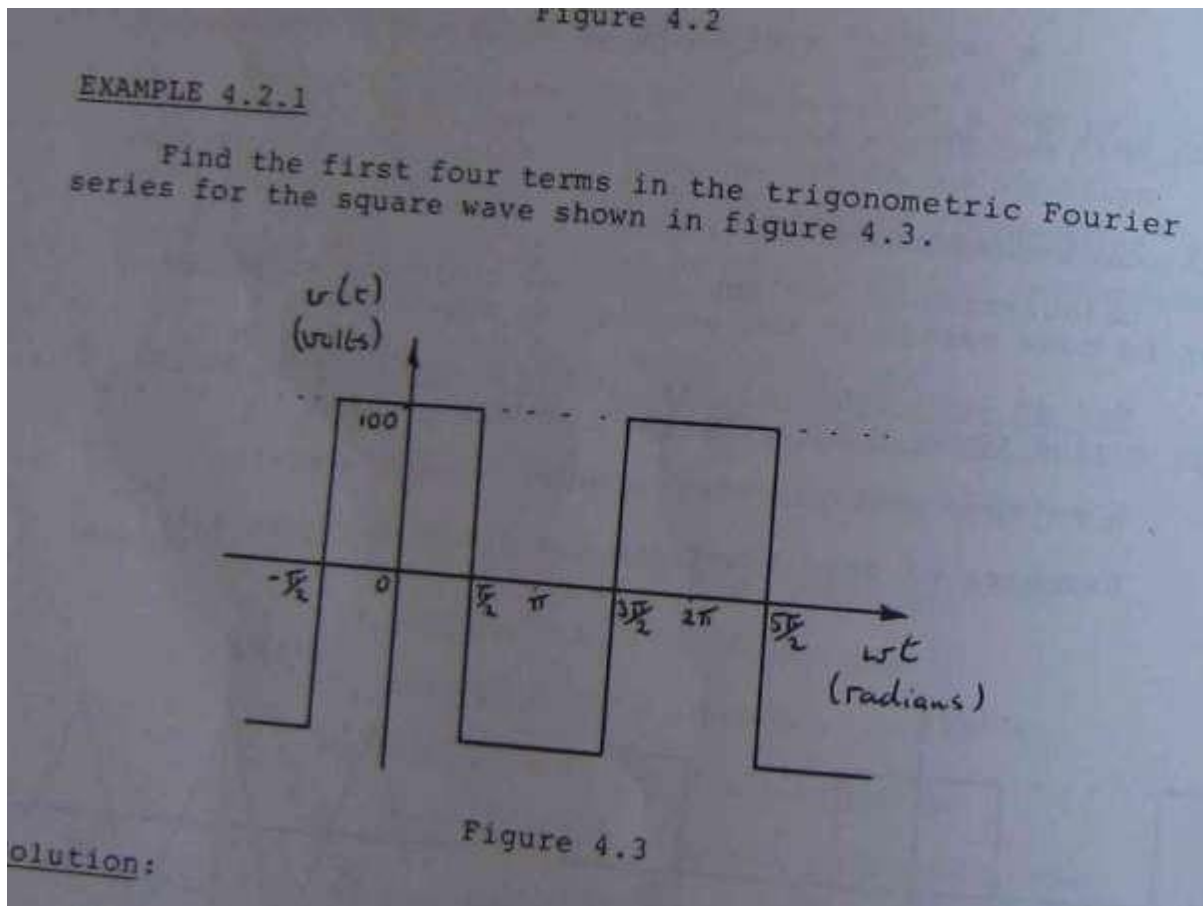

Slide 21

Q14. Write the equation to calculate  $V_{rms}$

Slide 22+23

Q15. For the series resonant circuit of the given figure. Find  $I$ ,  $V_r$ ,  $V_l$ ,  $V_c$

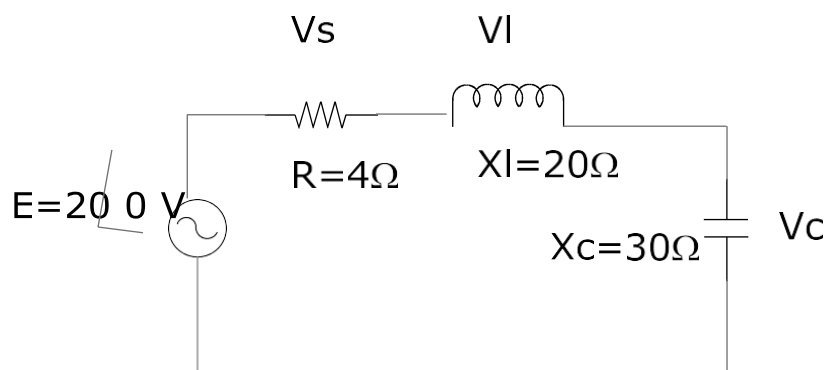

What is  $Q$  of the circuit (b) If resonant frequency is 6000 Hz, find bandwidth (d) power dissipation at half power frequency.

## (3) Ordinary differential equation

Slide 1

Q16.

$$\frac{dy}{dx} = 8x^2 \quad \text{Find Y}$$

Slide 2+3

Q17. Solve  $y'' = 8x - 3$ ,  $y(0) = 1$ ,  $y'(1) = -4$ 

Slide 3+4

Q18.

$$\frac{dy}{dx} + 4y = 7 \quad y(0) = 3 \quad \text{Find the equation.}$$

Slide 5

Q19

Solve

$$\frac{dy}{dx} = \sec y \tan x$$

Slide 6+7

Q20. Find general equation of

$$(5X + XY^2)dX + (Y + 2X^2Y)dY = 0$$

Slide 8

Q21. In above problem, find the particular equation for  $y(1) = 3$ 

Slide 9+10+11

Q22. Solve

$$X \frac{dy}{dx} - 3y = X^3 \cos 5X$$

---

(4) linear differential equation

Slide 1+2+3

$$x \frac{dy}{dx} - 4y = x^3 \cos 6x$$

(5) Application of logarithm

Slide 1+2+3+4

Q24. Sketch log graph for 10,100,1000,10000,100000

(6) Beta, Gamma functions

Slide 1 to 6

Q25. Evaluate the each of followings

(a)	(b)	(c)	(d)
$\Gamma(5)$	$\Gamma(5/2)$	$\Gamma(2) \Gamma(2.5)$	$6\Gamma(8/3)$
-----	-----	-----	-----
$2 \Gamma(2)$	$\Gamma(1/2)$	$\Gamma(5.5)$	$2\Gamma(2/3)$

Slide 7 to 15

Q26.

$$\int_0^2 x^4 (1-x)^3 dx$$

Slide 16+17

Q27.

$$\text{Solve } \int_0^{\pi/4} \sin^3 \theta \cos^4 \theta d\theta$$

(7) Vector analysis

Slide 1 to 7

Q29. If  $A = A_1i + A_2j + A_3k$



$$\mathbf{B} = B_1\mathbf{i} + B_2\mathbf{j} + B_3\mathbf{k}$$

$$\text{Prove } \mathbf{A} \cdot \mathbf{B} = A_1 B_1 + A_2 B_2 + A_3 B_3$$

Slide 8 to 10

If  $\mathbf{A} = 4\mathbf{i} - \mathbf{j} + 3\mathbf{k}$      $\mathbf{B} = 8\mathbf{i} + 4\mathbf{j} - 2\mathbf{k}$  Find (a)  $\mathbf{A} \cdot \mathbf{B}$  (b)  $\mathbf{A} \times \mathbf{B}$

---

(8) Laplace transform

Slide 1 to 10

Q32. Find the Laplace transform of the followings

(a)  $4e^{-5t}$  (b)  $8t^3$  (c)  $8 \cos 8t$  (d)  $\sin 12t$

Slide 11

Q33. Find Laplace transform of

$-4$

$$\sqrt{t}$$

Slide 12

Q34. Find Laplace transform of  $8 \sin 3t - 4 \cos 4t$

Slide 13

Q35. Find  $\mathcal{L}(\sin 2t + \cos 2t)$

---

(9) Sufficient condition for Laplace transform

Q36. What is the condition to apply Laplace transform

---

(10) Inverse Laplace

Slide 1 to 6

Q31. Find

(a) 8

$$\mathcal{L}^{-1} \frac{\text{-----}}{S+3}$$

(b)

$$\mathcal{L}^{-1} \frac{5S-4}{S^2+5}$$

(c)

$$\mathcal{L}^{-1} \frac{2S-3}{S^2}$$

(11) Gamma function in Laplace transform

Slide 1+2

Q32. Find

$$\mathcal{L}^{-1} \frac{4-3S}{S^{5/2}}$$

Q33. Find

$$\mathcal{L}^{-1} \frac{1}{S^2+3S}$$

(12) Laplace transform in differential equations

Slide 1+2

Q34. A resistor  $R = 20 \Omega$  Inductor 4 H and a voltage E volt are connected in series with switch S .

At  $t = 0$ , the switch is closed and  $I = 0$ .

Find I for  $t > 0$  if (a)  $E = 50V$  (b)  $E = 30 e^{-4t}$  (c)  $E = 60 \sin 7t$

Slide 3+4

Q35. Solve  $30 e^{-4t} = 3 \frac{dI}{dt} + 20I$

---

(13) Matrix & Numerical method

Slide 1

Q36

$$A = \begin{vmatrix} 3 & 1 & 5 \\ -2 & 0 & 2 \end{vmatrix} \quad B = \begin{vmatrix} 5 & -4 & 1 \\ 7 & 1 & 3 \end{vmatrix}$$

Find  $A+B$ ,  $A-B$ ,  $4A$

Slide 2 to 14

Q37. Solve  $4X_1 + 7X_2 + 8X_3 = 20$

$$12X_1 + 14X_2 + 9X_3 = 15$$

$$5X_1 + 6X_2 + 9X_3 = 25$$

Slide 15+16

Q38. If  $P_0(X) = 2$ ,  $P_1(X) = X$  Find (a)  $P_2(X)$  (b)  $P_3(X)$  (c)  $P_4(X)$

Slide 17 to 19

Q39. Expand (a)  $(20+X)^4$ . (b)  $(4+X)^5$ . (c)  $(8+7X)^3$

Q40. Expand  $(7-8X)^3$

---

14) Legendre function

Slide 1 to 7

Q41. Expand the function  $f(x) =$

$$1 \quad 0 < x < 1$$

$$0 \quad -1 < x < 0$$

In the series

$$\sum_{k=0}^1 A_k P_k(X)$$

Slide 8+9

Q42. Find  $A_3(X)$  and  $P_3(X)$

-----  
 (15) Partial differential equation, multiple integral

Slide 1+2

Q43. If  $v = F(y-3x)$

$$\text{prove } \frac{\partial v}{\partial x} + 3 \frac{\partial v}{\partial y} = 0$$

Slide 3 to 6

Q44. Find the volume of region R bounded by parabolic cylinder  $Z = 4 - X^2$  & planes  $X = 0, Y=0, Y=6, Z=0$

Slide 7+8

Q45

Q45 Find the following partial differential equation

$$(a) \frac{\partial}{\partial y} 3X^2 \cos y$$

$$(b) \frac{\partial}{\partial y} 4X^3 - \tan y \sin \theta$$

$$(c) \frac{\partial}{\partial y} 3(X^2 + 2y)^3$$

$$(d) \frac{\partial}{\partial y} 3(X + 2y)^5$$

Slide 10 to 12

Q46.

Find

$$\int_{y=1}^{y=3} \int_{x=0}^{x=2} X^2 + 3y \, dx \, dy$$

$$\int_1^2 \int_2^3 \int_0^{\pi/4} \text{Sec}\theta \tan\theta \, d\theta \, dx \, dy$$

$$\int_1^{y=32} \int_0^1 e^x \, dx \, dy$$

E029+G006 (G012+E-46)

(1) Electric motor selection +application

Slide 1

Q1.What are the factors to be considered for selection and application of electric motor?

Slide 2

Q2.Sketch the characteristics of induction motor

Slide 3

Q3.Three voltages, phase to neutral are measured to be 230, 218 and 209 V on normal 415 V 50HZ supply. Determine the % voltage imbalance for 220V.

Slide 4

Q4.Sketch the graph for de-rating factor and % voltage imbalance.

Slide 5

Q5. Write the equation to calculate synchronous speed slip speed, motor current & voltage relation, motor torque & voltage relation.

Slide 6+7

Q6. Sketch the diagram for normal cage rotor.

Slide 8

Q7.Sketch the graph for power factor and efficiency.

Slide 9

Q8.Explain the duty cycle & class of rating of induction motor.

-----

(2) Duty type of motor

Slide 1+2+3

Q9. Describe the duty type of motor

Q10. 3 phase 15 Kw 415 V 50Hz 1440 RPM squirrel cage induction motor has the designation H5 what does this designation indicate?

Q11.define the term “ starting torque’ as applicable to electric motor.

Q12.Interpret motor classification S2 & S 6

Slide 4+5+6

Q13.Describe the classification & types of motor enclosures

Slide 7+8+9

Q14. Describe the types of mounting and bearing for motors.

Q15. Interpret the following motor classification symbol. IP22, IP 44, IC 01

Slide 9

Q16. Write the formula for calculation of motor acceleration torque.

Slide 10+11

Q17. A 15 Kw, 4 pole, 50Hz squirrel cage induction motor is used to drive a machine having considerable inertia.

Motor rotor has moment of inertia  $3.15 \text{ Kg-m}^2$  pulley has moment of inertia  $0.3 \text{ Kg-m}^2$ . Load has moment of inertia  $70 \text{ Kg-m}^2$ . Load is driven by a belt drive at half the speed of motor. Calculate (a) total moment of inertia (b) If motor full load speed is 1475 rpm, calculate the full load torque.

-----  
(3) Induction motor starting

Slide 1

Q18. To drive the following loads. Describe the required starting torque of electric motor compressing, belt conveyor drive, rock crushing.

Slide 2+3+4

Q19. A cyclic process has a starting load of 50KW rising in a linear ramp fashion in 15 sec to 260 KW. During the next 30 sec the load is constant at 320 Kw. It then falls abruptly to 60KW at which value, it remains constant for 60 sec. When the cycle repeats, determine a suitable size of motor for application.

Slide 5

Q20. The electrical power supply company set the requirement that 415V 3 ph motor starting current shall not exceed  $53+3.3K$  where K is the output rating of the largest motor in Kw. If 3 ph 25 KW motor is connected to other motors in load group with similar capacity, calculate the permissible starting current.

Slide 6

Q21. Write the names of reduced voltage starters

Q22. Write the method of current interrupting

Slide 7+8

Q23. Sketch auto transformer starter and express the starting current and torque equation.

Slide 9+10

Q24. 30 KW, 4 poles 415V motor full load current is 30 amp starting current is 62% of rated current starting torque is 150% of full load torque. Determine the locked current & torque at starting for (a) Star/Delta starting (b) primary resistance starting (c) auto transformer starting at 70% tapping.

..... -  
(4) Induction & synchronous motor (E029+G006)

Slide 1+2

Q25. Sketch the diagram of induction motor and synchronous motor.

Slide 3

Q26. Sketch the installation diagram of synchronous motor in PF improvement.

Slide 4

Q27. Write down the starting current and torque of synchronous motor.

Slide 5

Q28. Describe the motor protection methods.

Slide 6+7+8+9

Q29. Sketch the pole connection diagram of 3 phase induction motor.

..... -  
(5) Density, friction, linear motion

Slide 1+2+3

Q30. Determine the mass of air in room 15m x 7m x 3 m . Density of air = 1.325 kg/ m<sup>3</sup>

Q31. 750 ml sulphuric acid has a mass of 1.7 Kg. What is the density & relative density of sulphuric acid?

Q32. Determine specific volume of air at sea level and normal temperature?

Slide 4+5+6

Q33. A body mass 6 Kg rest on a horizontal surface and the coefficient of friction between two surfaces is 0.35. What horizontal force will be required to start the body moving?

Slide 7



Q34. A horizontal force 60N is required to start a 20Kg block moving in horizontal surface. What is the value of friction coefficient?

Slide 8+9

Q35. A 150 Kg block rests on a plane. The coefficient of friction between all surfaces is 0.25. Determine the force required to pull the plate from under the block.

Slide 10+11+12

Q36. Find the total emergency stopping distance of a car and total time taken from the point where the driver sights the danger if the driver's reaction time before applying the brake is 0.9 sec. Initial velocity is 65 km/hr and retardation due to brake is  $8 \text{ m/s}^2$

-----  
(6) Force, mass , acceleration

Slide 1

Q37.

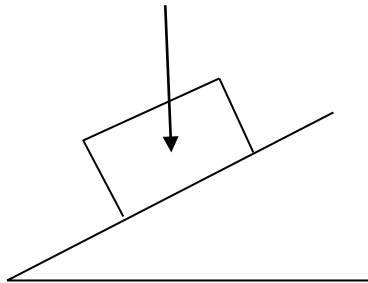

Determine the acceleration of a body sliding down a smooth plane inclined to horizontal at 30 degree.

Slide 2+3

Q38. A train of total mass 130 ton is travelling at 70 km/hr on level track. The tractive resistance is 90N/ton. Calculate the tractive effort required to accelerate the train to 130 km/hr in 35 second.

Slide 4

Q39. Determine the acceleration of bodies A & B and the force of tension in the cord for the system.

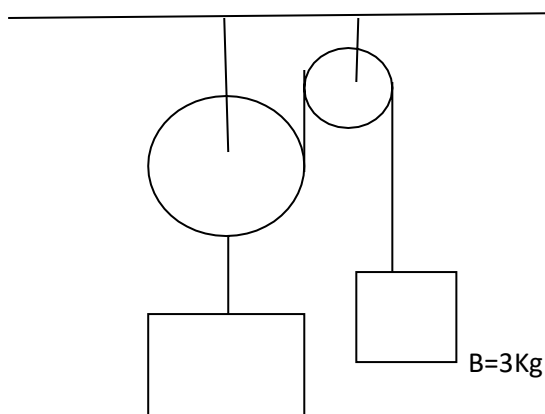

A = 6 Kg

Slide 7+8

Q40. A flywheel starts from rest and accelerates at the rate of  $2.7 \text{ rad/s}^2$  for 35 sec. Calculate angular velocity of 7 rad/sec, brakes are applied to the flywheel producing a retardation of  $5 \text{ rad/s}^2$ . Determine the time taken to reduce its angular velocity to 45 rad/sec

-----  
(7) Torque , work ,power energy

Slide 1+2

Q42. Determine the net torque required to give a flywheel with a mass moment of inertia  $0.8 \text{ kg-m}^2$ , angular acceleration is  $18 \text{ rad/s}^2$ .

Q43. Determine the torque required to accelerate a turbine rotor under going a dynamic balancing test from rest to a speed of 16000 rpm in 8 sec. If the mass moment of inertia of rotor is  $12 \text{ kg-m}^2$ .

Slide 3

Q44. Determine the centrifugal force acting on a passenger of mass 80 kg in a car travelling at 95 km/hr around a curve of 150 m radius.

Slide 4

Q45. Determine the work done by the force of 60N moving distance of 4 m in the direction of force.

Q46. A hoist lifts a load of 2 ton through a vertical distance of 28 m. Determine the amount of work done against gravity.

Q47. A flywheel makes zero revolution while the torque applied to it is 45N. Determine the workdone.

Slide 5+6+7+8

Q48. A hoist lifts a load of 2 ton through the vertical distance 25m in 30 sec. What is average power?

Q49. A train moving at 68 km/hr requires 45 KN of tractive effort at this speed . Determine the driving power.

Q50. An output shaft of an electric motor rotates at 1500 rpm and produces torque 85 N-m what is shaft power?

Slide 9+10

Q51. Calculate the potential energy of a drop hammer which has a mass of 1.5 ton and is raised 1.8 m above the pile head before being allowed to drop freely in order to drive it into ground.

Q52. Calculate the kinetic energy of a vehicle of 1800 Kg mass moving with velocity of 90 Km/hr .

Slide 11+12+13

Q53. Calculate the kinetic energy of mass moment of inertia of  $65 \text{ kg-m}^2$  rotating at 300 rpm.

Q54. A rocket of 3 ton mass is fired vertically upward with a velocity of 300 m/s what is momentum.

Q55. A block of mass 3 kg is freely suspended on a string. A bullet of mass 80 g is fired horizontally into the block. If the velocity of the bullet before the impact is 400 m/s, calculate the velocity of block with the bullet embedded in it immediately after the impact.

(8) Impulse

Slide 1+2

Q56. When a golf ball having a mass 60 g is struck by club. The ball and club are in contact for 0.002 sec immediately after the impact. The ball travels at 48 m/s. Determine the average force of collision.

Slide 3

Q57. The exhaust gas from a rocket has a velocity of 1300 m/s and flows at a rate of 7 kg/s. Determine the thrust produced by gas.

Slide 4

Q58. A simple machine is represented diagrammatically in the given figure. The load is 500 N. The effort is 60 N. The distance moved by the load and effort are 150 mm and 1300 mm respectively. Calculate MA and VR.

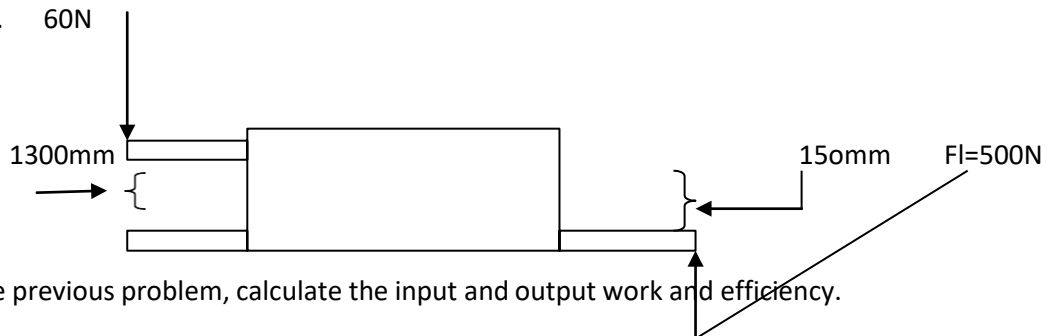

Q59. For the previous problem, calculate the input and output work and efficiency.

Slide 6+7

Q60. A machine can lift 500 N with velocity ratio 10. Actual force is 70 N. Calculate the frictional effort.

(9) The law of machine.

Slide 1+2+3+4

Q61. The machine has to be tested under different loads and the following effort.

Load $F_l$	0	100	200	300	500
Effort $F_e$	5	25	45	65	105

Plot load/ effort graph and determine the law of machine.

Slide 5

Q62. In previous problem, calculate the efficiency for each load and lifting efficiency.

Slide 6+7+8

Q63. The following question refers to the same machine.

- Given that effort required to lift a load of 8 ton is 400N. Calculate Mechanical advantage.
- If the effort moves 250 mm for every mm moved by the load, calculate output work and input work.
- If the load is lifted, a total distance of 1.87 m, calculate the output work and input work.
- Calculate the efficiency.
- Calculate fractional effort.

-----  
(10). Mechanical Drive System

Slide 1+2

Q64. The input shaft of a gear box rotates at 1480 rpm and transmits torque. The output shaft rotates at 600 rpm and transmits the torque 170 N-m. Determine the input and output power and efficiency of the drive.

Slide 3+4

Q65. Determine the weight of a tubular steel column 130mm outside diameter 150mm inside diameter and 4.5 m high.

Slide 5+6+7

Q66. A steel test specimen, 15mm diameter ruptured under load 47 kN. What was the ultimate strength of the steel.

Q67. A portable testing machine for carrying out crushing tests on concrete applies an axial force of 483N which causes compression failure in a concrete specimen. 180mm diameter and 350 mm high. What is the ultimate compressive strength of concrete?

---

(11) Power Factor measurement

Slide 1+2

Q68. Draw the circuit diagram to measure PF.

---

(12) Stress and strain

Slide 1+2

Q69. If a bar of mild steel 25 mm x 15 mm in CSA is subjected to trust force 20KN. Determine the stress in material.

Slide 3

Q70. Determine the minimum required diameter of the high tensile steel rod to carry a tensile load 30 KN with a safety factor 4.5

Slide 4+5

Q71. If the diameter of mild steel pin in given figure is 15 mm and the maximum force applied to the coupling is 12 KN. What is the shear stress in material of the pin and safety factor .

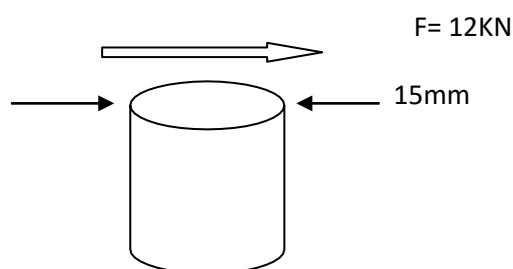

Slide 6+7

Q72. Determine the required diameter of a single mild steel belt , holding 2 overlapping strips of metal against a shear stress in force of 5 KN . If the allowable stress in shear is 120 Mpa

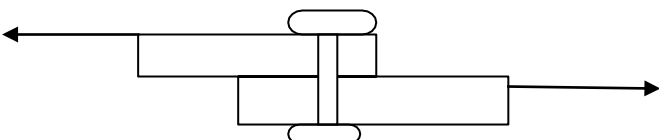

---

(13) Power and machine

Slide 1

Q73. Study the questions and answers for slide.

Slide 2

Q74. A transformer has no load 3 KW & full load copper winding . Power loss is 5 Kw when it is delivering one third load current. Find total losses.

Slide 3

Q75. Study questions and answers.

Slide 4

Q76. If 4 pole alternator is producing electricity at 60Hz, find the speed.

Slide 5.

Q77. Study question and answer.

E050

(1) Power index + Graph

Slide 1

Q1. Solve  $(8X^3=9X+1) (8X^3-X^2-12)$

Q2. Expand  $(7X-5) (X^2-5X+4)$

Slide 2

Factorise

Q3.  $2X^2+7X-9$

Q4.  $8X+18$

Q5.  $18-24a$

Q6.  $ab+a$

Q7.  $16XY-8X^2$

Q8.  $15X^2Y-20aX^2+5X^2$

Q9.  $3a^2b^2+6ab^2$

Slide 3

Q10. Factorise  $16e^{4X}-4e^{3X}$

Q11. Solve  $\frac{e^{2X}+3e^{3X}}{e^{-X}+3e^X}$

Slide 4+5+6+7

Q12 Factorise

(a)  $X^2+4X+3$

(b)  $2Q^2+16Q+24$

(c)  $3Z^2+21Z+30$

(d)  $X^2+8X+15$

(e)  $E^2+11E+24$

Slide 8+9

Q13. Solve  $\frac{16X^2+80X+96}{4X^2-36}$

$$\text{Q14.(a) } \frac{6-4K}{3} = \frac{3(K-8)}{K}$$

$$\text{(b) } \frac{X-6}{3} = \frac{5-3X}{X-3}$$

$$\text{(c) } \frac{5}{2R+3} = \frac{3+2R}{7}$$

Slide 10

$$\text{Q15 Solve } (X-8)(X+3) = 3X-1$$

Slide 11+12+13+14

$$\text{Q16 Plot } Y = 3X^2 - 24X + 15$$

Slide 15

Q17. The following values of X and Y are believed to satisfy the equation of  $Y = aX^2 + bX$ . Find a linear equation that suits this information and evaluate a & b.

X	1	2	3	4	5
Y	10	32	68	114	168

(2) Logarithmic graph

Slide 1+2+3

$$\text{Q18. Evaluate } \log_9 1/9$$

$$\text{Q19. } \log_3 4 \sqrt[4]{5} = ?$$

Slide 4+5

Q20. If an amplifier has an input power at 0.0018 watts output 6.8 watts. Calculate power gain dB

Q21. An amplifier has input power 25mW

(a) Output 6.8 watts, find power gain.

(b) Attenuator has input power 17.6 watts, output power 9 mW. Find attenuation.



Slide 6

Q22.  $\log_2 (0.7V + 0.3) = -3$

Q23. Solve  $3^x + 5 = 18$

Q24.  $\log_{10} \frac{K}{(2K-X)} = t$  Find X

Slide 7+8+9+10+11+12

Q25. Plot  $X$  vs  $Y = \log_{10} X$  for the following X values  $X = 0.2, 0.4, 0.6, 0.8, 1, 2, 3, 4, 5$

-----

(3) Circular function & trigo

Slide 1

Q18. Convert the followings into radian

(a)  $90^\circ$

(b)  $270^\circ$

(c)  $130^\circ$

Slide 2+3

Q19. Use circular function & find the values of the following angles.

(a)  $\tan 140^\circ$  (b)  $\tan 280^\circ$  (c)  $\tan 180^\circ$  (d)  $\sin 60^\circ$  (e)  $\sin 325^\circ$

Slide 4+5+6

Q20. Plot the following graphs

(a)  $8 \sin (\theta + 80^\circ)$

(b)  $60 \cos (\theta - 30)$

(c)  $19 \cos (\theta - \pi/6)$

(d)  $15 \sin (\theta + \pi/6)$

Q23. Find the phase angle difference

(a)  $8 \sin (\theta + 80^\circ)$  &  $12 \sin (\theta + 40^\circ)$

(b)  $6 \cos (\theta + 10^\circ)$  &  $24 \cos (\theta - 70^\circ)$

-----

(4) Circular function & trigo

Slide 1

Q24. Convert the following analog into degrees

- (a)
- $\pi/5$
- (b)
- $2\pi$
- (c)
- $\pi/3$
- (d)
- $\pi/15$
- (e)
- $3\pi/12$

Slide 3

Q25. Sketch  $8 \sin(146 \times 10^3 t - 0.855)$  mA

Slide 4+5

Q26. Sketch  $v = 280 \cos(314t + 78)$  volt

Slide 6+7

Q27. Find period and angular velocity of

- (a) 70HZ (b) 165HZ (c) 30MHz

Find the frequency and angular velocity of 3sec

Slide 8

Q28. Calculate (i) the period (ii) amplitude of the given curves

(a)

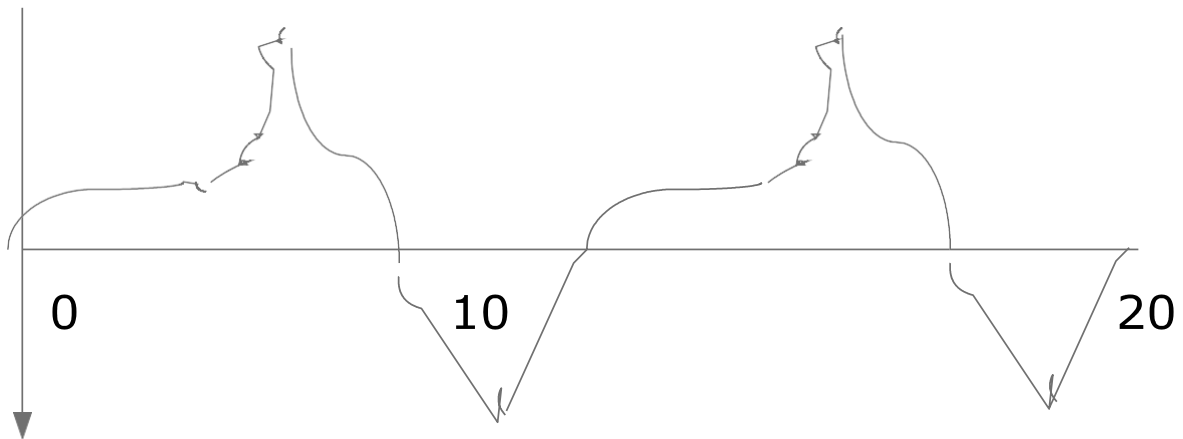

(b)

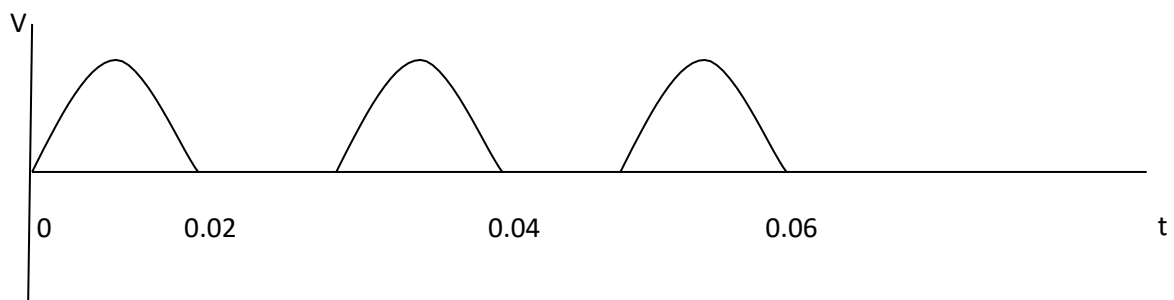

(c)

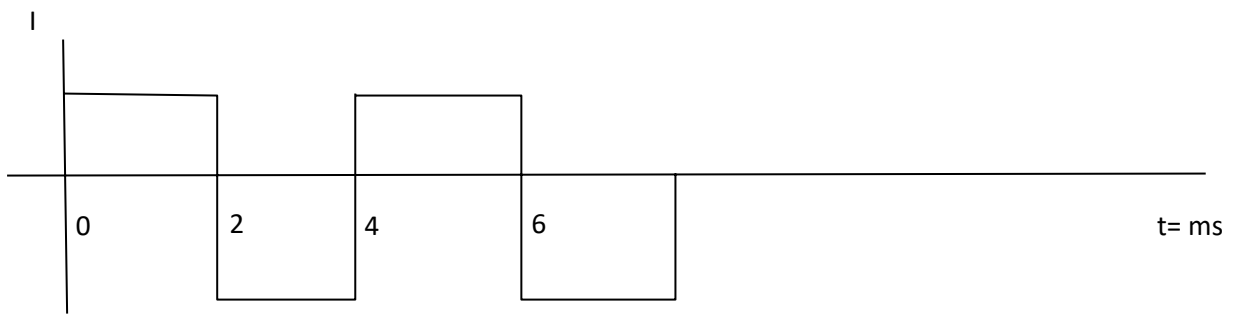

Slide 9+10

Q29. Plot (a)  $Y=9\sin 4\theta$ (b)  $Y=230 \sin 0.5 \theta$ 

Slide 11

Q30

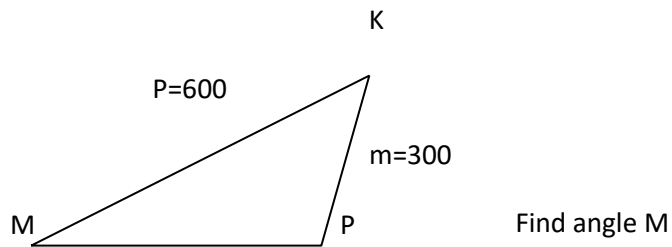

Slide 12

Q 31.

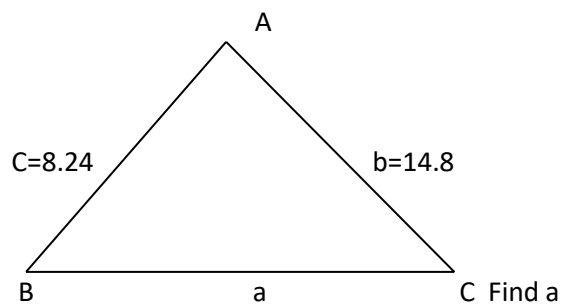

(5) Trigonometric Identities

Slide 1+2+3

Q32. Prove that  $\operatorname{cosec} \theta - \sin \theta = \cos \theta \cot \theta$ Q33. Simplify  $\operatorname{cosec} \theta$  $\sec \theta$ Q34. Simplify  $\cos(90^\circ - \theta)$  $\sin \theta$ 

Q35. Simplify

(a)  $\tan^2 \theta - \sec^2 \theta$

(b)  $\cot^2 \theta - \operatorname{cosec}^2 \theta$

(c)  $\sqrt{\operatorname{cosec}^2 \theta - \cot^2 \theta}$

Q36. Prove  $\sqrt{\frac{1 - \cos^2 \theta}{1 - \sin^2 \theta}} = \tan \theta$

Q37. Prove  $\frac{\sec^2 A - 1}{1 + \tan^2 A} = \sin^2 A$

Q38.  $\frac{\cos^2 \theta - 1}{1 - \sec^2 \theta} = \cos^2 \theta$

Slide 4+5

Q39. Prove

(a)  $\cos^2 X \tan^2 X + \cos^2 X = 1$

(b)  $(\cos \theta + \sin \theta)(\cos \theta - \sin \theta) = 2\cos^2 \theta - 1$

Q40. Prove

(a)  $\frac{\sin X}{-\cos X} - \frac{\sin X}{1 + \cos X} = 2 \cot X$

(b)  $\frac{1 + \cot \theta}{\operatorname{cosec} \theta} = \frac{\tan \theta + 1}{\sec \theta}$

Slide 6

Q41. Prove  $\cot A \cos A = \operatorname{cosec} A - \sin A$

Q42. Simplify  $\sec^2 \theta - \sin^2 \theta = \cos^2 \theta$

Q43. Simplify  $\cos \theta \cdot \cos 2\theta - \sin \theta \sin 2\theta$

Slide 7

Q44. Simplify  $\sin^2 \beta \sin \delta + \cos^2 \beta \sin \delta$

Q45. Simplify  $\sin(X+Y) \sin Y + \cos(X+Y) \cos Y$

Q46. Express  $\frac{\sin(A+B)}{\sin A \sin B}$  in terms of  $\tan A$  and  $\tan B$

Sin(A-B)

Slide 8

Q47. Find the exact value of  $\sin 15^\circ$  &  $\sin 75^\circ$ 

(6) Vector

Slide 1 + 2

Q48. If a body undergoes a displacement in 13 m due north followed by a displacement of 7 m due east. Find the displacement and direction.

Slide 23+4+5

Q49.

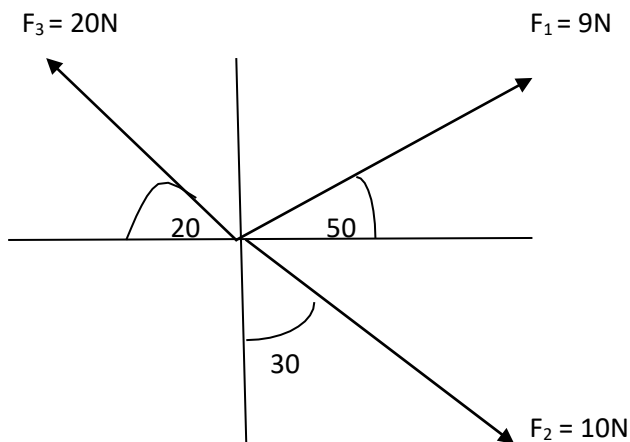

Slide 6

Q50

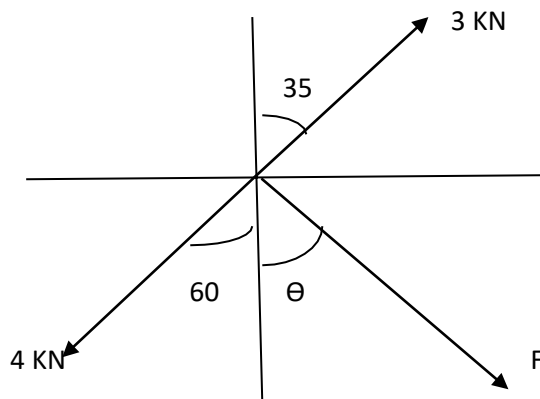
Find  $F$  &  $\theta$  if the system is in equilibrium

Slide 7

Q51.

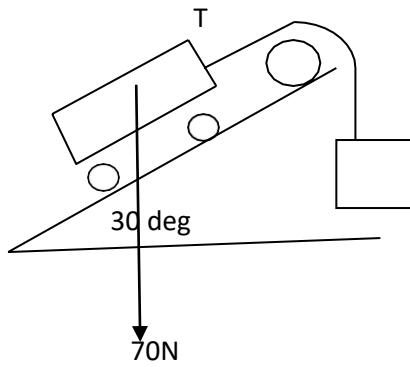

Find T if the system is equilibrium.

Q52.

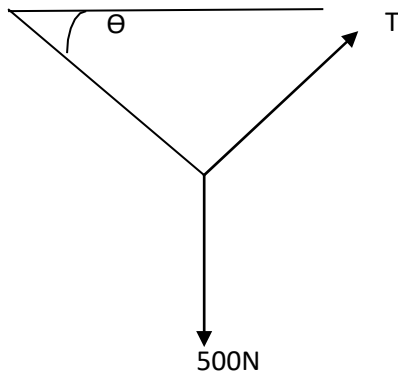
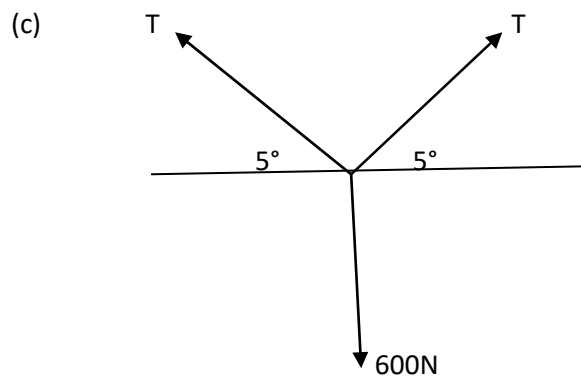
Find T &  $\theta$ 

Slide 9+10+11+12

Q53. Locate point (3,7) & (4,5) on the co-ordinate plane and find (a) Distance between points (b) Gradient

Q54.  $36 = 8 + 7X$  Find gradient

-----

(7) Area

Slide 1+2+3+4+5+6+7+8

Q55. Find the areas of the following shadings

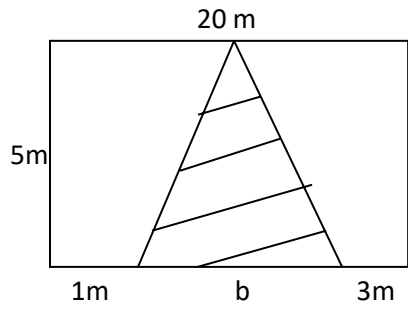

Q56.

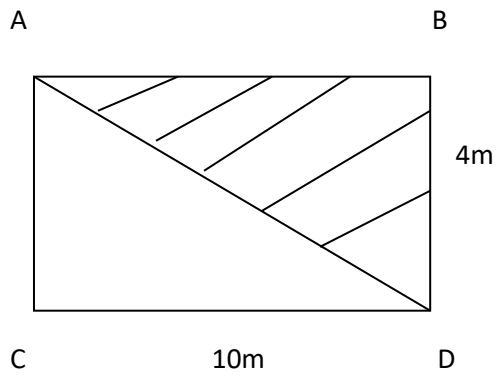

Q57.

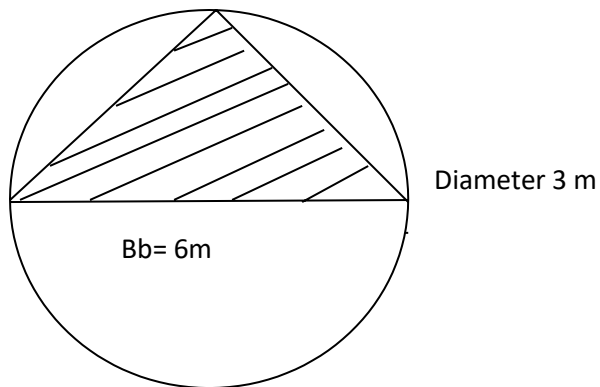

Q58

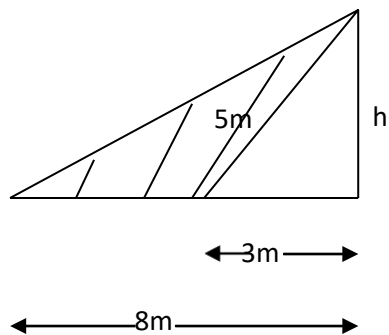

Q59.

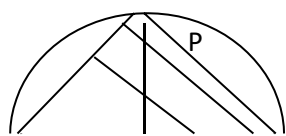

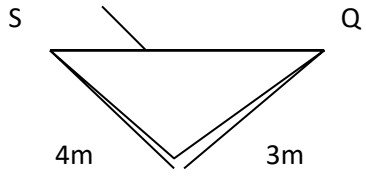

Q60.

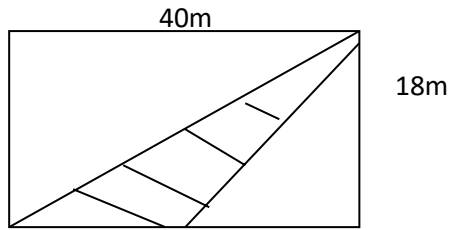

Slide 9+10+11

Q61.

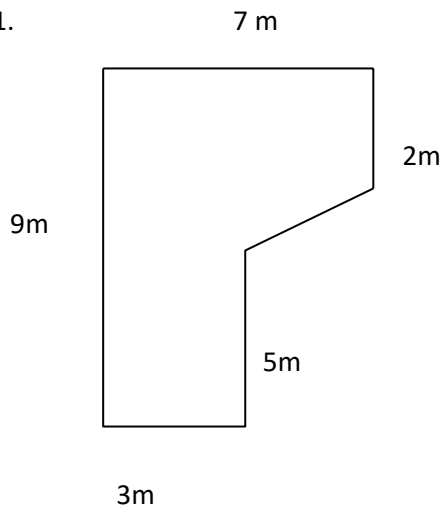

Q62.

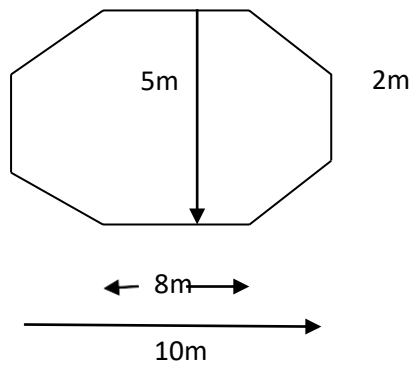

Q63.

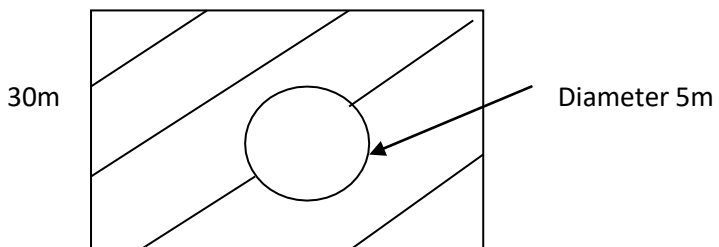



40m

Slide 12+13+14

Q64. Find the area

Q65.

Q66.

---

(8) Differentiation

Slide 1+2

Q67.  $Y = 5X^4 + 6X^3 + 7X^2 + 8$  find  $dy/dx$ Q68.  $Y = \sin 2X + \cos 3X$  Find  $dy/dx$ 

---

(9) Successive differentiation

Q69. Differentiate  $y = \frac{X}{X+1}$

$$X^2 + 3X + 1$$

Q70  $y = \frac{X^2 - 3X + 1}{\dots}$  Find  $dy/dx$

$$X^2 - 3X + 1$$

Slide 4+5

ax  $Q71$  Differentiate (1)  $y = e^{ax}$  (2)  $y = e^{\frac{1}{2}bx + x}$

Slide 6+7

Q72. Differentiate (1)  $\log_e X^2$  (2)  $\log_e (X^2 - 1)$  (3)  $\log_e \sin X$

Slide 8

Q73.  $Y = X^4 + 3X^3 + 2X^2 + 7$  Find  $dy/dx$   $d^2y/dx^2$

Slide 9

Q74. Find the first three differential coefficients of the function.

$$Y = \frac{1}{2X + 1}$$

Slide 10+11+12

Q75. Differentiate

(a)  $Y = X^9$

(b)  $Y = X^4$

(c)  $Y = m X^k$

(d)  $Y = (X - 3)^4$

(e)  $Y = 4 X^{-4.2}$

(f)  $Y = 3.2 (2X + 3)^{1/5}$

Q76. Differentiate

(a)  $Y = 2X^{3/2} + X^{-3/2}$

(b)  $Y = 7X^6 + 6X^5 + 4X^4 + 3X^2 + 2X + 1/3$

(c)  $Y = \frac{1}{\sqrt{X}} + \frac{1}{\sqrt[3]{X^2}}$

(d)  $Y = -X^{-2} + 1/X + X^2$

Q77. The induced emf of a dc machine is given by  $E = 0.68 + 700 I_f - 701 I_f^2 + 13 I_f^3$ , Find field excitation current  $dE / dI_f$

Q78 Differentiate

(a)  $(X+1)^{1/3}(X-3)$

(b)  $(2X+7)^3(4X^2-5)^2$

(c)  $(5X^2+6X+7)(5X-1)$

(d)  $\frac{4-X}{X-X^2}$

$X^{-2}$

$X^{1/5}$

(e) .....

$X^{1/2} - 1$

Slide 12+13+14+15

Q79. Differentiate the following exponential functions

(a)  $e^{-ax}$

(b)  $e^{(X^2+3X)}$

(c)  $\text{Log}_e(X^2+2X+3)$

(d)  $a^{x^2+1}$

(e)  $x^{\sin x}$

Q80. The current growth in a resistive inductive circuit from a suddenly applied battery is given by

$$I = E/R (1 - e^{-Rt/L})$$

Where E, R L are constants . Find the rate of change of current in time.

(10) Differentiation

Slide 1

Q81.  $Y = \sin^3(3X^2 + 1)$  find  $y'$

Slide 2

Q82.  $X^2 + Y^2 = 9$  find  $dy/dx$

Slide 3+4

Q83. Differentiate  $y \log_e X = 2$

Slide 5+6+7+8

Q84. Differentiate the following trigonometric functions

(a)  $\sin(20X + 5) + \cos(8X + 3)$

(b)  $\tan^3 4X$

(c)  $\sec X \tan X$

(d)  $\operatorname{cosec}^5(X^2 + 1)$

(e)  $\cot 7X \sin 6X$

(f)  $1 - 10 \sin 20t + 5 \sin 30t + 8 \sin 40t$

Slide 9

Q85. The potential difference across an inductor of self inductance  $L$  is

$$V_L = L \frac{di}{dt}$$

If  $i = 20 \sin (300t + 70^\circ)$  Find the potential difference  $V_L$

Slide 10+11+12

Q86. The self inductance of a reactor winding of a salient pole synchronous machine is

$$L = L_0 + L_2 \cos 2\theta$$

Where  $L_0$  and  $L_2$  are constants and  $\theta$  is the angular position of rotor. Find the rate of change of inductance with angular position.

Slide 13

Q87. Find the first two differential coefficient of the following functions.

(a)  $\text{Log}_e(X^2 - 1)$  (b)  $\sin^2 X$  (c)  $e^{X^2/2}$  (d)  $a^x$

(11) Integration

Slide 1

Q88. (a)

$$\int \frac{8}{X} dx$$

(b)  $\int X^{\frac{1}{5}} dx$

Slide 2

Q89.

Solve

(a)

$$\int X^{-4} dx$$

(b)  $\int X^{\frac{2}{5}} dx$

(c)

$$\int X^{-1/5} dx$$

(d)

$$\int (X^5 + 2X^4) dx$$

Slide 3

Q90.

$$\int (2X + 3)^4 dx$$

Q91.

$$\int (-3X + 2)^{-2/3} dx$$

Slide 6

Q92. Integrate

(a)  $X^6$  (b)  $\frac{2}{3} X^{-1/3}$  (c)  $6 X^{-3}$  (d)  $3 X^{1/6}$  (e)  $\frac{1}{3} X^{-2/3} + X^3$  (f)  $(2X + 4)^4$  (g)  $(1+X)^{-5}$  (h)  $(3-X)^{1/3}$

(i)  $(7X + 7)^{1/3}$  (j)  $(3X - 8)^{-5/2}$

Slide 7+8

Q93.

$$\int \sin^2 X dx$$

Q94

$$\int \cos^2 X dx$$

Q95.

$$\int \cos^2 2X dx$$

Q96

$$\int \tan^2 4X dx$$

Slide 9

Q97

$$\int (\sin X \cos X) dx$$

Q98

$$\int (\sin 2X \cos 2X) dx$$

Q99

$$\int (\sin 4X \cos 5X) dX$$

Slide 12+13+14+15+16

Q100. Integrate

- (a)  $\sec^2 X$
- (b)  $\tan X$
- (c)  $\cos 5X$
- (d)  $\sin 7X$
- (e)  $\cot X$
- (f)  $\operatorname{cosec} X \cot X$
- (g)  $\sec X \tan X$

Slide 17+18+19+20

Q101

$$(a) \int e^{-x} dx$$

$$(b) \int X e^{X^2} dx$$

Q102. Integrate the followings

(a)  $e^{-4x}$

(b)  $2e^{7x}$

(c)  $5e^{-1/5 x}$

(d)  $3x e^{-x^2}$

(12) Integration applications- Electrical

Slide 1

Q103 Find the average value of current for saw tooth wave period  $T = 0.1$  sec

Slide 2

Q104. Find average value of current for full wave rectified dc voltage wave.

Slide 3+4+5

Q105. Find RMS value of (a) Triangular wave (b) sinusoidal wave

Slide 6

Q106. Find RMS value of complex wave

Slide 7+8+9+10

Q107. Find  $I_{RMS}$  of  $I(t) = 10 \sin 100t + 15 \sin 200t$

Q108. A voltage waveform is represented by the equation  $v(t) = 20 - 30 \sin wt$  volt

Determine (a) average value (b) RMS value (c) Form factor



Slide 11+12+13+14+15

Q109. Determine average value, RMS value and form factor

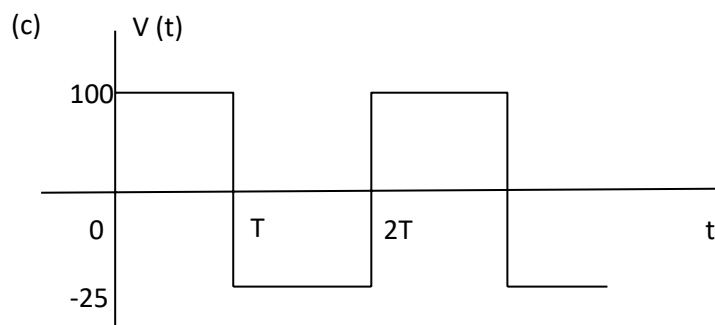
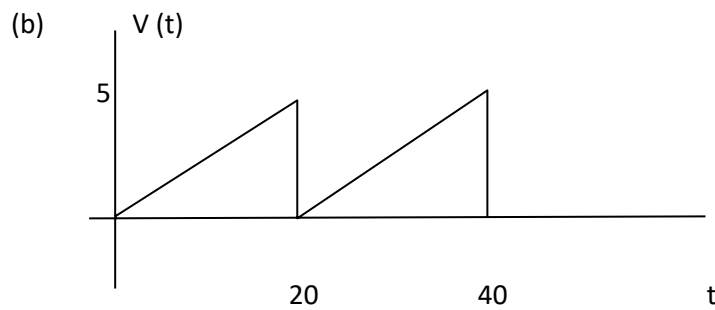
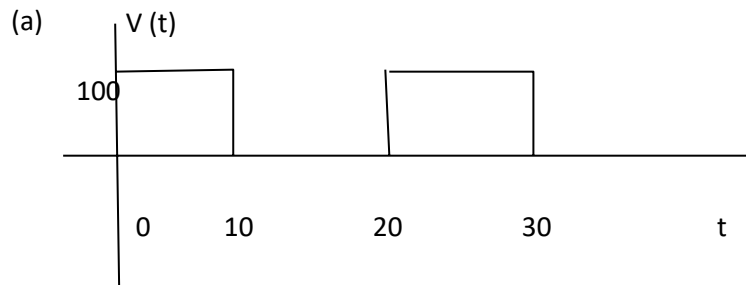

Slide 16+17+18

Q110. If a  $110\Omega$  resistor dissipates an average power of 1000 watt . Determine

- (a) RMS value of current (b) Maximum value of current if the waveform is sinusoidal (c) Maximum value of current if the waveform is triangular
-

## (13) Differential equation

Slide 1+2+3

Q111.

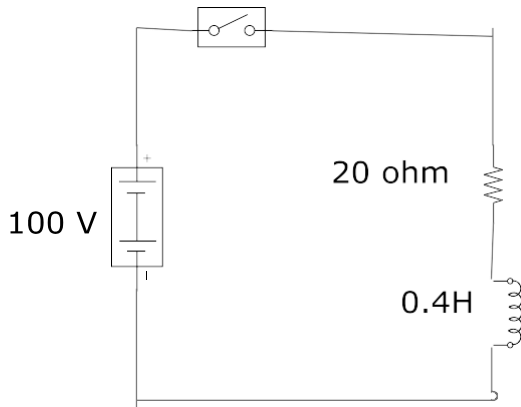

For the circuit shown above determine the following values after the switch is closed

- (a) The final value of current
- (b) The initial value of current
- (c) Time constant of the circuit
- (d) The equation of the current

Slide 4

Q112.

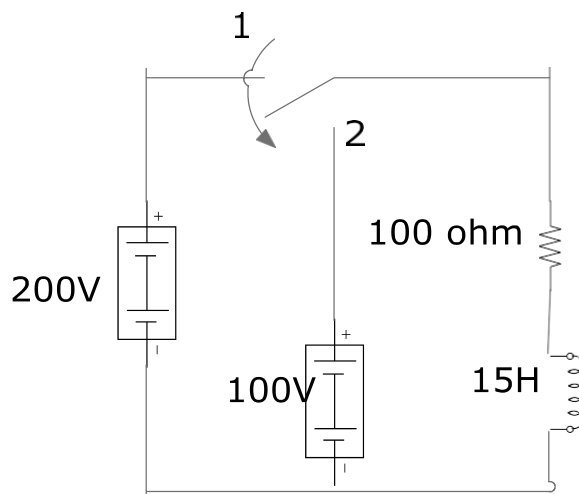

Determine the equation of the current in above figure after switching in position 2. Assume that the steady state current has been attained in position 1

Slide 5+6+7

Q113. An emf  $e = 200 \sin(314 t + \theta)$  volt is applied to a coil of resistance  $400 \Omega$  and inductance  $0.6 \text{ H}$  while  $\theta$  is  $20^\circ$ . Determine the equation of the resultant current to the coil.

Slide 8+9

Q114. An emf of  $e = 300 \sin(700t + \theta)$  volt is applied to a RC circuit where  $R = 500 \Omega$  and  $C = 7 \mu\text{F}$  when  $\theta$  is  $70^\circ$ . Determine the equation of the current if the initial charge on capacitor is  $400 \mu\text{C}$ .

---

(14) RL-RC 2<sup>nd</sup> order

Slide 1+2+3+4

Q115.

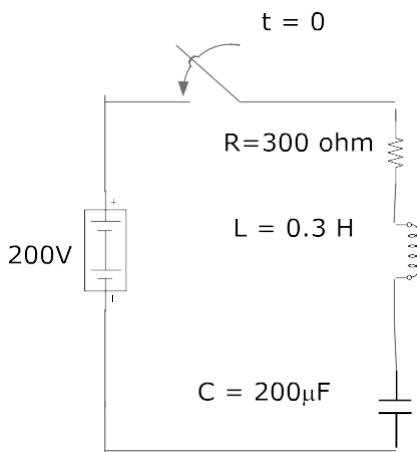

In the given circuit, determine the equation of current if initial charge on capacitor is zero.

Slide 5+6

Q116

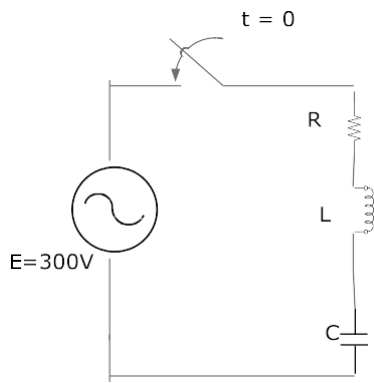

$E = 300V$   $R = 300 \Omega$   $L = 0.7H$   $C = 400\mu F$ . Find the equation of the current if the initial charge on the capacitor is 30 milli-coulomb

(15) Statistics and data collection

Slide 1+2+3+4+5

Q117. A population of 5 sales persons selling car phones to both private and commercial customers over a period of one month. The numbers of telephones sold for each person is shown in the following table.

Sale person	Phones sold
Thomas (A)	13
Barry (B)	25
James (C)	10
Matthew (D)	7
Phillip (E)	17

- List all possible samples of size
- For each sample, calculate data range, sample means, sample standard deviation.
- Calculate mean, frequency, relative frequency
- Graph

Q118. In above problem, calculate mean of distribution and sample mean.

Slide 6

Q119. A certain brand of rope is known to have a mean breaking strength 30 kg with a standard deviation of 0.7 kg. A random sample of rope is tested for breaking strength. What is the possibility

that sample mean breaking strength of 60 pieces of rope will be (a) between 29.9 & 30.1 kg (b) less than 29.8 kg

Slide 7+8+9+10+11

Q120. A certain large company is interested in whether or not there is a relationship between the amount spent on advertising per month & the gross sale volume. To examine this expenditures and associated same volume selected for monthly basis.

Month	Advertising expenditure \$10000	Sale Y x \$ 10000
1	1.2	101
2	.8	92
3	1.0	110
4	1.3	120
5	0.7	90
6	0.8	83
7	1.0	93
8	0.6	75
9	0.9	91
10	1.1	108

Slide 12+13+14+15

Q121. Find the mode of the following

(a) 18,19,18,20,18,18,20,21,37,18

(b) 27,28,29,30,14,20

(c) 19,18,20,35,18,18,19,46,19

Q122. Find the medium of the followings

(a) 8,4,3,9,12

(b) 17,20,17,21,19,19,21,22,38,29

Q123. Find the mean of the following graph frequency distribution

Interval	Frequency	Interval	Frequency
0 to 9	1		
10 to 19	2		
20 to 29	4		
30 to 39	9		
40 to 49	4		
50 to 59	2		

Slide 16

Q124. Find the range of the following sample of data.

(a) 17,18,17,19,17,30,20,19,17,17

(b) 17,18,17,19,20,19,17,17

Slide 17

Q125. 9, 11, 14, 16, 20

Calculate (a) Mean (b) Residual (Deviation)

Slide 18+19+20

Q126. Calculate the variance of 9, 11, 14, 16, 20

Q127. Calculate variance and standard deviation for the sample of data.

$X = 1, 2, 4, 4, 8$

Slide 21

Q128. Find the standard deviation of the following sample of grouped data

Interval	Frequency
10 to 14	3
15 to 19	6
20 to 24	4
25 to 29	2

30 to 34

1

-----

(16) Statistics-Probability

Slide 1

Q129 A bag contains 6 red balls , 4 blue and 3 green balls . Find the probability that if one ball only is drawn randomly , it will be green.

Slide 2+3+4

Q130. There are 52 cards in a standard pack in which 39 cards contain heart. Calculate the probability that the card containing heart is drawn and probability that the card not containing heart is drawn.

Slide 5+6

Q131. A single die is tossed. What is the probability of a 6 appearing on the upper most face given that number showing is even.

Slide 7+8+9+10+11+12+13

Q132. Suppose we have 3 events X,Y,Z

$$P(X) = \frac{1}{2} \quad P(Y) = \frac{1}{4} \quad P(Z) = \frac{1}{8}$$

Find (a)  $P(Z|X)$

(b)  $P(Z|X \cup Y)$

(c)  $P(X \cup Y)$

(d)  $P(\overline{X \cup Y})$

-----

(17) Probability distribution

Slide 1+2+3+4

Q133. Suppose that IQ score are normally distributed with mean  $\mu = 110$  , standard deviation  $\delta = 16$  .

Indicate the following on the graph

(a) Approximately 69% of people have IQ between 86 and 116

(b) Approximately 94% of people have IQ between 69 and 129

(c) Almost everyone (approximately) 99.8% have IQ between 56 and 146.

Slide 5+6

Q134. The distribution of adult female height has a mean  $\mu = 166$  cm standard deviation  $\delta$  (relative height to mean) = 7.8 cm. Find the standard score corresponding to a female height of (a) 163 cm (b) 177 cm.

Q135. The weight of a certain species of elephant are distributed with a mean of 21 tonne and standard deviation of 3 tonne. Suppose also that weight of garden snails are distributed with a mean of 31 gm and standard deviation 3.1 gm.

Which is heavier. An elephant 24 ton or a snail 35 gm

Slide 7

Q136. If a student shows the following results in a series of tests . Compare the overall performance.

Subject	Standard score	Mean $\mu$	Standard deviation
Maths	160	140	12
English	119	119	9
History	180	190	10
Science	100	90	7

Slide 8+9+10+11+12+13

Q137. Use Z table. Calculate the area between the standard normal curve for the following intervals

- (a) Between  $Z = 0$  &  $Z = 1.4$
- (b) Between  $Z = 0$  &  $Z = -2$
- (c) Between  $Z = -0.2$  &  $Z = 2.3$
- (d) The right of  $Z = 1.9$
- (e) To the left of  $Z = 1.65$
- (f) Between 0.59 & 1.7



E071

(1) Project specification

Slide 1+2+3+4+5

Q1.What contents are included in NSW Electrical Service Rule?

Slide 6

Q2.What are the aspects of electrical contracting

Slide 7

Q3.Before performing sale and marketing, what questions are to be raised?

(2) HV Conductor + sales & marketing

Slide 1+2+3

Q4.What are the required Australian Standards for 11KV OH conductors?

Q5.Describe the clearance requirement for OH conductors?

Slide 4+5+6+7+8

Q6.Sketch insulator & surge arresters and describe the components.

Slide 9

Q7.Write the requirements for top switches and pole transformers

Slide 10

Q8.Describe angle of deviation requirement and required construction for insulator construction.

Slide 11 +12+13

Q9.Write the specifications for HV aerial bundled cables

Slide 14

Q10.Write down the required Australian Standards for OH line construction.

---

(3) Line Infrastructure +material storage

Slide 1+2+3+4+5

Q11.Sketch 11KV pin construction , cross arm structure and provide the materials list. Describe safety testing. Also provide relevant Australian standard references .

Slide 7

Q12.Describe tools and materials storage system at worksite.

---

(4) Mechanical fittings+ light fixture+ purchasing

Slide 1+2+3+4

Q13. Write the specifications for LV OH conductor, fitting, erection , fusing and de-energizing procedures.

Slide 5+6

Q14. Write the specifications for installation of LV conductor from which consumer service main to be attached. Clearance from foot path and appropriate termination procedures are to be followed.

Slide 7

Q15.What are the steps to be followed for purchasing?

Slide 8+9

Q16.Draw a purchase order.

---

(5) Hazards identifications+ residential electrical contract.

Slide 1

Q17. What information are to be included in writing the specifications for hazardous identification.

Slide 2+3

Q18.Write a safety instruction for working near LV installation and system.

Slide 4+5+6+7

Q19.Prepare a general safety advice for the employees who are modifying the existing electrical installation or system

Slide 8+9+10+11+12+13+14+15+16+17

Q20.You are required to provide an electrical installation diagram and specification for main power supply for 1 phase 2 circuits. Sketch an electrical installation diagram and write the specification.

Slide 18+19+20

Q21.Explain the features of residential electrical contracting work.

---

(6) telecommunication +Insurance

Slide 1+2+3

Q22. What are the components of telecommunication system?

Q23.what are the important facts in writing of telecommunication specifications?

Slide 3+4

Q24.Sketch coaxial cable and indicate the components.

Slide 4

Q25.What are to be included in telecommunication specification?

Slide 5

Q26.Describe the types of end-office switching and accessories.

Slide 6

Q27.Explain the followings

(a) Pocket switching (b) digital transmission and switching

Slide 7+8

Q28.Explain the international telecommunication standards in group 3 & 4

Slide 9+10+11

Q29.Explain the insurance for electrical contracting

---

(7) Domestic electrical installation +Paper work

Slide 1+2+3

Q30. Write down the specifications for domestic electrical installation.

Slide 4+5+6+7

Q31. Explain the electrical regulation clauses for wiring systems.

Slide 8+9+10

Q32. Describe the paper work in electrical contracting.

Slide 11

Q32(a) Draw a service order form.

Slide 12

Q33. Write down the aspects of cutting cost.

---

(8) Pulling the cable into conduit + Management planning

Slide 1+2\_3+4+5

Q34. Write the steps for pulling cable into conduit.

Slide 7+8

Q35. Write the bending radii requirement for 11KV cable

Slide 9+10

Q36. Explain the management planning requirement for service work.

Slide 11+12+13+14

Q37. Write the specifications for concrete work.

Slide 15+16

Q38. Write the specification for cable pulling

Slide 17+18

Q39. Explain electrical contracting for speciality work.

Slide 19+20

Q40. Explain design & build work

---

(9) Design standard for Over head line+ Job accounting

Slide 1+2+3

Q41. Write the design standard for OH development.

Slide 4+5+6+7

Q42. Describe cable installation & bonding procedure.

Q43. Explain various types of distribution substations with sketches.

Slide 8

Q44. How do you understand job accounting?

Slide 9+10+11+12

Q45. Describe the followings

- (a) Complex system (b) sectional system.

Slide 13+14

Q46. Sketch Job order form and job record form.

---

(10) UG cable specification + contract bid work

Slide 1+2+3+4

Q47. Write the specifications for laying of UG cable up to 22KV.

Slide 5+6+7+8

Q48. Write the procedures for installation of conduits with sketches.

Slide 9+10+11

Q49. Explain (a) Contract bid work (b) Bonding (c) Contract (d) Documentation (e) Arbitration (f) Bidding

Slide 12

Q50. Provide sample quotation form.

---

(11) HV OH line protection + Job schedule

Slide 1+2

Q51. Explain the protection system for 11 KV / 22KV feeders

Slide 3

Q52.Explain the protection of LV OH network.

Slide 4+5

Q53.Describe insulation co-ordination & OH line protection.

Slide 5+6

Q54.Explain (a) Design parameters (b\_) Supply quality (c) Reliability

Slide 7+8

Q55.Explain sectional job schedule

Q56.Sketch sectional job schedule plan

Q57.Sketch (a) composite schedule (b) cash flow schedule

Slide 9+10

Q58.Explain office management & responsibility

Q59.Describe the duties of estimator

Slide 11+12

Q60.Write the duties of superintendent.

---

(12) Mechanical switches + manager+ estimator+ superintendent

Slide 1

Q61.Sketch the following switches

(a)No,SPST (b) NC, SPST (c) SPDT (d) push button

Slide 2

Q62.Describe (a) knife switch (b) Rotary selector switch

Slide 3+4+5+7

Q63.Explain (a) Limit switch (b) Manual motor starter (c) Mercury switch (d) Relay

Slide 6

Q64.What are the characteristics of contracting?

Slide 8

Q65 Describe any three types of electro magnetic relay

Slide 9

Q66. Sketch standard relay symbol.

Slide 10

Q67. Explain the followings with sketches (a) Relay (b) Solid state relay (c) Electro-mechanical relay

Slide 11+12

Q68. Explain any four different types of relay.

Slide 13+14+15

Q69. Explain the functions of owner/ project manager , estimator, superintendent.

Electrical Workshop

E001

(1)OHS + Manual Handling

Slide 1

Q1.Briefly explain the safety procedures to be obeyed in workplace

Slide 2

Q2.What are the factors & conditions that threaten the health and safety.

Q3.Explain heat stress and effect of it.

Q4.How will you prevent and control the cold?

Slide 3

Q5.What are psychological symptoms of stress?

Slide 4

Q6.What are to be careful to use electricity in workplace?

Slide 5+6

Q7.What are the dangers that can be caused by electricity?

Q8.What are to be checked to avoid electric shock?

Slide 7

Q9.What are to be careful in clothing to avoid danger at work?

-----

(2) Safety +Assembly+ Drawing

Slide 1

Q10.Explain the followings with sketches

(a) Electrical safety interlock

(b) RCD

Slide 2+3+4

Q11.Explain danger tagging

Q12.The method to rescue from live electrical situation.

Q13.Study questions 1 to 6.

-----



E002

Slide 5+6

Q16.What is the purpose of fixing?

Q17.Sketch the fixing by using drill, bolt and screw.

Slide 7

Q18.Write the procedures for drilling & fixing bolt and nut.

Slide 8+9

Q19.Express the list of equipments and tools for mechanical fitting

Q20.Write the procedures for drilling a large hole with sketches.

Slide 10

Q21.Sketch the failure of screw assembly.

---

E002+E005

Slide 1

Q22.Explain the setting instruction for ceiling suspension anchor with sketches.

Slide 2

Q23.What are the types of anchors?

Q24.Explain (a) ceiling suspension anchor (b) screw in anchor

Slide 3

Q25.Explain masonry nails setting instruction with necessary sketches.

Slide 4

Q26.Write setting instruction for built in fixings.

Slide 5

Q27.Write the setting instruction for plugs and sockets.

Slide 6

Q28.Describe the factors affecting the fastener's performance in dense concrete bases.

Slide 7

Q29.What are the types of mechanical fixings in timber bases?

Q30.Sketch the following wood nails (a) Round plain wire (b) Square twisted (c)Panel pin (d) Staple

Slide 8

Q31. Write the installation procedures for wood screw.

Slide 9

Q32. Sketch the assembly of shear plate connector.

---

(4) Fixing accessories +Soldering

Slide 1

Q33. Sketch the fixing with joist hanger.

Slide 2+3

Q34. Sketch cantilever bracket

Q35. Explain strength of mechanical fixings in timber bases.

Slide 4

Q36. Sketch (a) Lateral loading (b) Axial loading (c) Lap joint (d) Gusseted joint (e) Spacing of nails.

Slide 5

Q37. Describe corrosion and how to prevent it.

Slide 6+7

Q38. How will you make mechanical fixing in mass walling bases

Slide 8

Q39. Why soldering is done?

Slide 9+11

Q40. Explain (a) Epoxy (b) Welding (c) Soft soldering (d) Soldering process

Slide 10

Q41. Explain (a) solder (b) flux (c) characteristics of solder (d) temperature control

Slide 12

Q42. How will you inspect the solder joint?

Q43. Explain stripping of wire.

Slide 13

Q44. How will you make solder joint?

Q45. What are the characteristics of solder joint?

Slide 14

Q46. Sketch terminal soldering diagram.

---

E008

(5) Fixed electrical wiring + Home wiring circuit simplification

Slide 1

Q47. Describe the colour coding of wires.

Slide 2

Q48. Explain (a) PVC (b) MIMS (c) XLPE (d) PTFE

Slide 3

Q49. Describe colour coding of flexible cord.

Slide 8

Q50. Describe the features of (a) ASCR (b) Galvanized steel (c) UG cable

Slide 9

Q51. What are the applications of TPS cable?

Slide 10

Q52. What are the application of MIMS cable?

Slide 11+12+13

Q53. Sketch (a) Lopping in batten holder (b) looping at switch for wiring

Slide 14+15+16+17

Q54. Draw the circuit of socket outlet connection.

---

(6) Wiring circuit + 2 ways switching

Slide 1

Q55. Sketch (a) lighting control circuit (b) Fluorescent light

Slide 2+3+4+5+6

Q56. Sketch two ways light connection.

Slide 7+8

Q57. Sketch 5 ways switch connection.

Slide 9

Q58. Sketch forward/ reverse motor connection.

Slide 10

Q59.Explain power wiring.

---

E033

(7) Electrical safety test

Slide 1

Q60.Where is the switch to be connected?

Q61.Identify the polarity of socket outlet.

Slide 2+3

Q62.How will you test the polarity of socket outlet?

Slide 4+5

Q63.How will you test the polarity of switch & light in wiring?

Slide 6+7

Q64.Sketch the testing of Edison screw lamp holder.

Slide 8+9

Q65.Explain the polarity testing of a new installation with sketch.

Slide 10

Q66.Explain polarity testing of socket outlet with sketch.

Slide 11

Q67.How will you test insulation resistance?

Slide 12

Q68.What are the reasons for earthing?

Slide 13.

Q64.Sketch RCD protection.

Slide 14+15

Q65.Sketch DB protected by ELCB.

Slide 16

Q66.Sketch the simple test panel for metering current & voltage of appliances.

---

E003

(8) DC Circuit

Slide 1+2

Q67. Resistors 8 ohm and 9 ohm are connected in series to 24V, calculate (a)  $R_t$  (b)  $I$  (c) Voltage across each resistor.

Slide 3

Q68. An electric heater of 30 ohm is connected to 120 V through a cable of 1 ohm. Find current & voltage across heater.

Slide 4

Q69. Four resistors 2 ohm, 3 ohm, 4 ohm and 5 ohm are connected in series to 12V. Calculate the circuit current & potential difference across each resistor.

Slide 5.

Q70. A 35  $\Omega$  resistor is connected in series with a resistor of unknown value across 70V supply. If the current is 10 mA, calculate the value of unknown resistor.

Slide 6

Q71. Two resistors are connected in series to a 240V supply, one is known to have 300  $\Omega$  and voltage across it is 60V. Calculate (a) the value of second resistor (b) the circuit current.

Slide 7+8+9

Q72. Do the exercises on these slides.

Slide 10+11

Q73. Resistors of 6  $\Omega$ , 8  $\Omega$  and 40  $\Omega$  are connected in parallel to 24V supply. Calculate the supply current.

Slide 12+13

Q74. Resistors of 44K  $\Omega$ , and 88 K $\Omega$  are connected in parallel to 100V. Calculate (a) total circuit resistance (b) total circuit current (c) individual branch currents.

Slide 14

Q75. Resistors of values 24  $\Omega$  and 16  $\Omega$  are connected in parallel with  $R_3$  of unknown value across a 12V supply. When the current from the supply is 3A, calculate (a) the value of  $R_3$  (b) current flowing in  $R_3$ .

Slide 15.

Q76. Four resistors of 30  $\Omega$ , 80  $\Omega$ , 40  $\Omega$  and 12  $\Omega$  are connected in parallel with each other and connected to 120V supply. Calculate total current.

Slide 16+17

Q77. Do all exercises.

---

(9) DC series and parallel circuit.

Slide 1+2+3

Q78. A  $2\ \Omega$  resistor is connected in series with parallel combination of  $8\ \Omega$  and  $9\ \Omega$  resistors to  $12\text{V}$  supply. Calculate (a)  $R_t$  (b) Each resistor current.

Slide 4

Q79. Resistors of  $3\ \Omega$  and  $8\ \Omega$  are connected in series and parallel across  $4\ \Omega$  and  $5\ \Omega$  series combination. They are connected to  $12\text{V}$  supply. Calculate (a)  $R_t$  (b)  $I_t$  (c) Each resistor current.

Slide 5

Q80. Five resistors are connected as follows. Find (a)  $R_t$  (b)  $I_t$  (c)  $3\ \Omega$  resistor current.

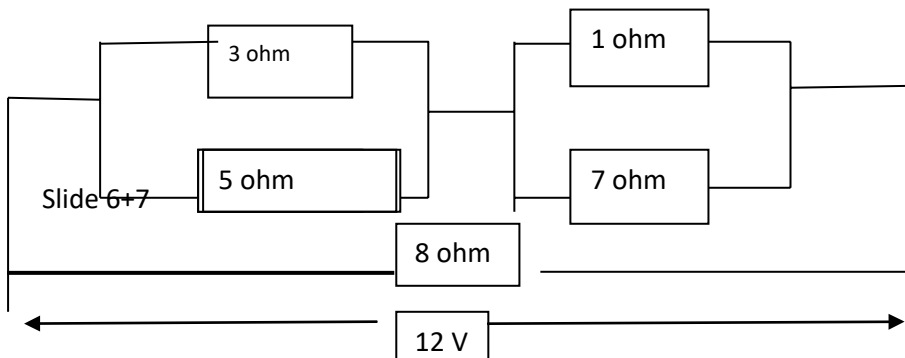

Q81. A resistor has a voltage of  $3\text{V}$  across it and draws a current  $500\text{mA}$ . Find the power.

Q82. The voltage across  $20\ \Omega$  resistor is  $1\text{V}$ , calculate the power dissipated in it.

Slide 8

Q83. Resistors  $2\ \text{k}\Omega$  and  $4\ \text{k}\Omega$  are connected in series to  $24\text{V}$  supply. Calculate the power dissipated in each resistor and total power.

Slide 9

Q84. Do all exercises

---

## (10) Lamp and resistor circuits

## Slide 1

Q85. An indicator lamp rated at 12V, 2W is required to show when a 24V supply is switched on. Calculate the resistance and power rating of suitable dropper resistor.

## Slide 2

Q86. 3 filament lamp indicators are each rated 24V and 0.72 W. If they are connected in series, what supply voltage should be used? Find supply voltage, the current and total power dissipated.

## Slide 3

Q88. Do all exercises.

## Slide 4+5+6

Q89. A circuit is fed with a 12V supply but a 5V ground potential is required at the base of a transistor. If this voltage is to be derived from 20 k $\Omega$  resistor connected to ground. Calculate the value of second resistor forming potential divider.

## Slide 8

Q90. A linear potential divider pot has a total resistance 60 k $\Omega$  and is connected across a 12V supply. If a voltage 4 V is required with one end connected to positive side of supply. What will be the resistance values on either sides of the tapping and through what fraction of its total possible movement from the positive end will the slider have to be moved.

## Slide 9

Q91. Do all exercises.

## (11) Wheat stone bridge

## Slide 1+2+3

Q92.

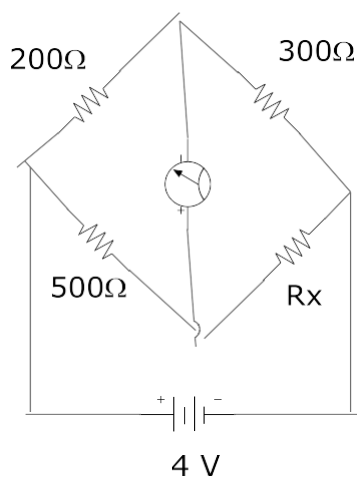

Find  $R_x$

Slide 4

Q93

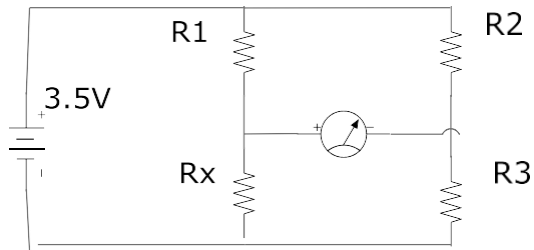

If  $R_1 = 500\Omega$ ,  $R_2 = 700\Omega$ ,  $R_3 = 40\Omega$ . Find  $R_x$

Slide 5+6

Q94.

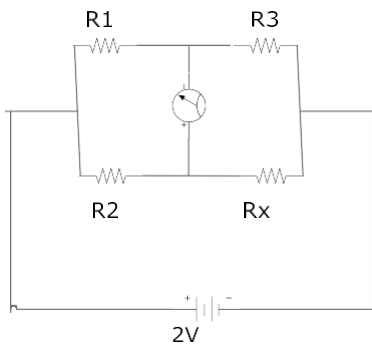

Find  $R_x$

Slide 7

Q95. Do exercises.

Slide 8+9

Q96. Sketch the electro-plating process.

Slide 9+10

Q97. Sketch &amp; explain electric cell.



Slide 11+12

Q98. A cell has emf 2V and internal resistance 1 ohm. Calculate its terminal voltage at (a) No load (b) providing 300mA current (c) when connected to a load of 10 ohm.

Slide 12+13

Q99. A battery is made by connection 10 cells in series. Each has 2V and internal resistance 0.2 ohm. Calculate (a) EMF & internal resistance of battery. (b) The terminal voltage when supplying 400mA. (c) The current & terminal voltage when a load of resistance 20 ohm is connected to battery.

Slide 14.

Q100. Do all exercises.

G001+G002

(1) Magnetism + Electro-magnetic

Slide 1

Q1. What is magnetic shielding?

Q2. Sketch a magnetic field around current carrying conductor.

Q3. Sketch magnetic field around two like poles & unlike poles.

Slide 2

Q4. Sketch the diagram for right hand rule.

Q5. Write the equation for magneto-motive force.

Q6. What are the application of electro-magnet.

Slide 3

Q7. Compare the electric circuit & magnetic circuit.

Q8. Write the equation for magnetizing force.

Slide 4

Q9. Sketch flux density VS magnetizing force for cast iron, cast steel and silicon steel.

Q10. Write the equation for flux density.

Slide 5.

Q11. Write the equation for force and torque of current carrying conductor.

Slide 6

Q12. A 300 V voltmeter has resistance  $300,000\Omega$ . If meter coil has 5000 turns, calculate total magnetomotive force of the coil for full scale deflection.

Slide 7.

Q13. What flux is produced in a magnetic circuit with a reluctance of  $40,000$  amp-turns/wb when its coil of 700 turns, a current of 2 amp from the supply.

Q14. A plunger brake electro-magnetic operates at a flux density of 3.5 tesla. If the CSA of the magnetic circuit is  $0.06$  sq-m and reluctance is  $30,000$  amp-turn / wb, what current is required to operate the magnet if the coil has 3000 turns.

Slide 8

Q15. The conductor of a coil can safely carry a current of 1 amp and when wound into a coil is required to produce a flux of 0.08 wb in a magnetic circuit which has reluctance  $300,000$  amp-turns/wb. Calculate the number of turns required on the coil.

Slide 9

Q16. A 300V coil of 7000 turns produces a magnetizing force of 5000 amp-turn/m. If the magnetic circuit is 300 mm long and has CSA 600 sq-mm, find the reluctance of the coil.

Q17. A core of 7000 mm<sup>2</sup> CSA has a resistance of 70,000 amp-turns/wb and the coil on it has 100 turns and a maximum current carrying capacity of 3 amp. Calculate the maximum flux density in core.

-----

(2) Electro-magnetic induction

Slide 1

Q18. a contactor coil has 35000 turns and a series resistance of 700 ohm. If the coil is connected to 200V dc supply, calculate (a) the magneto-motive force (b) the power absorbed by the coil.

Slide 2

Q19. A lifting magnet has an operating coil of 800 turns with a resistance of 50 ohm. If the magnet is 350 m from the switch board and the interconnecting cable has a resistance of 5 ohm/ 1000m, calculate the voltage required at the switch boards to produce the coil magnetomotive force of 5000 amp-turns.

Slide 3

Q20. The core of a solenoid measures 40m x 40m in section and has a reluctance of 35000 amp-turns / wb. Calculate the current required in the energizing coil having 850 turns to produce a flux density of 4 tesla.

Slide 4+5

Q21. A conductor 0.4m long is moving at right angle to the magnetic field at a velocity of 7m/s. Calculate the electromotive force if the flux density is 3 tesla.

Slide 6

Q22. What is the velocity of a conductor 25000 m long and moving at right angle to magnetic field having a flux density of 1.8 tesla? The induced voltage is 6V.

Q23. A conductor moves at a velocity of 4.5 m/s in a magnetic field which has a flux density of 2.4 tesla. If the conductor is 1900 mm long and carries a current of 8 amp, determine (a) Electro-motive force (b) force exerted on the conductor (c) power dissipated.

Slide 7+8

Q24. A conductor which is 750 mm long moves at a velocity of 4.5 m/s. When it carries a current of 32 amp, the force exerted on the conductor is 6.4 N. Calculate (a) flux density (b) power generated by conductor (c) EMF induced.

Slide 9

Q25. A coil of 35 turns has a flux linking it at 0.7 wb. If this flux changes from 0.5 wb to 0.2 wb in 200 ms, calculate the induced emf in coil.

-----

## (3) Inductor

Slide 1+2

Q26. A transformer has 100 turns on the primary and 700 turns on secondary. If a flux of 0.4 wb is induced to zero in 10 ms, calculate the induced emf in each coil.

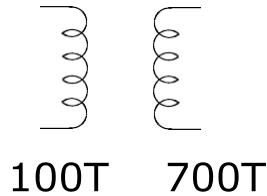

Slide 3+4

Q27. If a conductor is being rotated at 2000 RPM in magnetic field and induces 400V at 1000 RPM. Find the induced emf.

-----

## (4) Relay

Slide 1

Q28. What are the applications of electro-magnetic induction?

Q29. Sketch the basic relay

Slide 2

Q30. Sketch the connection of magnetic relay circuit.

-----

G002

## (1) 3 phase AC circuit basic

Slide 1+2

Q1. Write  $6+j8$ ,  $-6+j8$ ,  $-6-j8$ ,  $6-j8$  in polar form

Q2. Convert  $13 \angle 36.8^\circ$  and  $13 \angle 120^\circ$  to rectangular form

Slide 3+4+5

Q3. Sketch the voltage and current waves in 50V ac supplied to 50 ohm resistor, 5 ohm inductor and 5 ohm capacitor.

Slide 6

Q4. Sketch the waveform and vector diagram for the following AC voltages

$$80 \angle 0 \quad 120 \angle -30$$

Q5

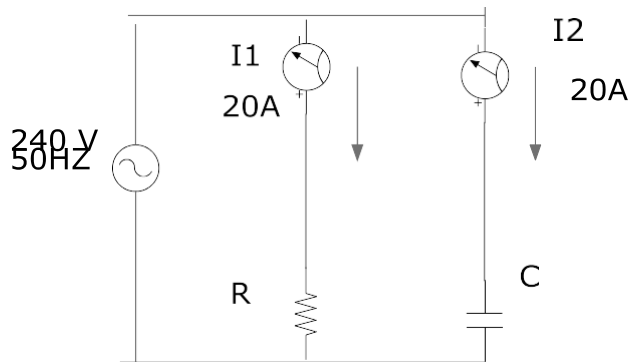

Draw the vector diagram for given circuit.

Slide 7

Q6.

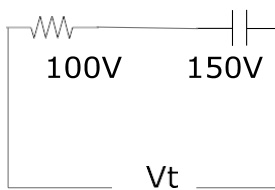

Draw the vector diagram for given circuit.. Find total voltage.

Q7. The circuit shows a choke (inductor) in series with a resistive industrial oven. The voltage across resistor is in-phase with the current and the voltage across the inductor leads the current by 90 degree. Draw a phasor diagram for the circuit showing  $V_1$ ,  $V_2$  and  $V_s$

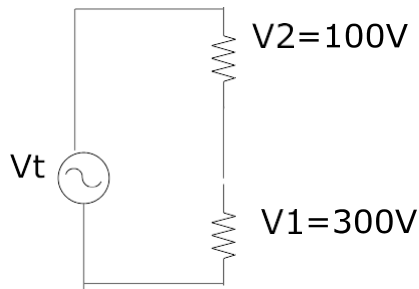

Slide 8+9+10

Q8. The frequency of a sine wave that has a period of 20 ms is \_\_\_\_\_.

Q9. A sine wave has a peak value 400 v. determine (a) RMS value (b) Average value

Slide 11

Q10. A sine wave has a maximum value of 200V, frequency of 60Hz. Determine the value of wave form at (a) 45 electrical degree (b) 90 electrical degree. (c) 210 electrical degree (d) after 5 ms.

Q11. Determine the periodic time for the following waveforms (a) 60Hz sine wave (b) 250 Hz square wave (c) 2000 Hz triangular wave.

Q12. Calculate the frequency for (a) 0.04 sec (b) 0.2 sec (c) 0.15 sec

Slide 12

Q13. For the waveform shown in figure, determine (a) maximum value (b) frequency (c) period (d) peak to peak value (e) RMS value

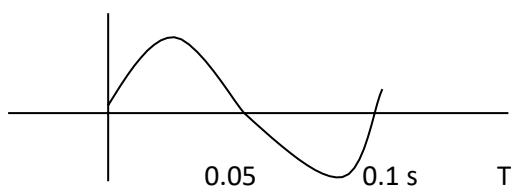

Q14. A single conductor of length 3 m is moving through a magnetic field of 1 tesla at velocity of 3 m/s, determine the induced voltage of the conductor in the magnetic field at (a) 30 degree (b) 60 degree (c) 120 degree

Slide 13+14

Q15. Study the review questions

-----

G049 Part 1

(6) Apparent, Real, Reactive Power

Slide 1+2

Q1. A load impedance  $300 \angle 36.9^\circ \Omega$  is supplied by same voltage  $600 \angle 0^\circ$  V. Find (a) apparent power (b) real power (c) reactive power.

Slide 3

Q2. Find the apparent, real and reactive power when a voltage  $V = 300 \angle 30^\circ$  V is supplying a load whose impedance is  $20 + j20 \Omega$ .

Slide 4

Q3. A network has an equivalent impedance  $Z = 6 + j8 \Omega$  and applied voltage  $V(t) = 50 \sin(2000t + 45^\circ)$ . Find (a) apparent power (b) real power (c) reactive power (d) power factor.

-----

(7) Three phase voltage

Slide 1+2+3+4

Q4. A 4 wires three phase supply is connected to a balanced three phase load. If  $V_{an} = 300 \angle 0^\circ$  V,  $Z_a = 40 \angle 45^\circ \Omega$ . Phase sequence ABC, find  $I_A, I_B, I_C$  and  $I_N$ .

Slide 5+6

Q5. Three identical impedance of  $34 \angle -40^\circ \Omega$  are connected to 415 V three phase 4 wires supply. The load is connected in star. Phase sequence is ABC. Find the line current & draw the phasor diagram.

-----

(8) Star / Delta load

Slide 1+2

Q6. In three phase system in followings are AC voltages and currents

$$I_A = 48 \angle -30 \text{ amp} \quad I_B = 48 \angle -150 \text{ amp} \quad I_C = 48 \angle 90 \text{ amp} \quad V_{AN} = 480 \angle 0 \text{ V} \quad V_{BN} = 480 \angle -240 \text{ V} \\ V_{CN} = 480 \angle +120 \text{ V} . \text{ Find total power.}$$

Slide 3+ 4+ 5

Q7. Three phase three wires 415 V ABC system supplies a delta connected load whose phase impedance is  $70 \angle 30 \Omega$  . Find the phase currents and line currents. Draw phasor diagram.

Slide 6+7+8+9+10+11

Q8. A delta load has three impedances.  $Z_a = 400 \text{ ohm}$ , in series with 700 mH inductor,  $Z_b = 200 \text{ ohm}$  in series with 50 micro farad capacitor.  $Z_c = 1000 \text{ mH}$  inductor . Line voltage = 415 V. Frequency 50HZ.  $E_{ab}$  is reference. Find all line currents.

Q9. A voltage  $V = 400 \sin 5000t$  is applied to resistance 300 ohm in series with 10 micro farad capacitor. Calculate (a) apparent power in VA (b) real power watt (c) Reactive power VAR (d) PF (e) draw the power triangle.

Slide 12+13

Q10. Solve  $(3 + j2)(1 + j2) + (2 - j2)^2$

$$4 + j8 + \dots\dots\dots$$

$$8 + j10$$

Slide 14+15+16

Q11. A three phase three wire, 415 V ABC system supplies a delta load where impedance is  $70 \angle 30 \Omega$  . Calculate three phase power.

Q12. In previous problem, if sequence is ACB, find power and line currents.

-----



## (9) Star/ Delta unbalanced load

Slide 1+2+3+4

Q13. A three phase 4 wires 400V supplies a star connected unbalanced load.

 $Z_A = 20 \angle -60 \Omega$     $Z_B = 8 \angle -90 \Omega$     $Z_C = 15 \angle 40 \Omega$  Calculate  $I_A$ ,  $I_B$ ,  $I_C$  and  $I_N$ . Draw phasor diagram.

Slide 5+6+7+8

Q14. In previous problem, if phase sequence is CBA, find line and neutral currents.

## (10) Unbalanced delta load

Slide 1+2+3

Q15. Calculate line currents for given delta connected load

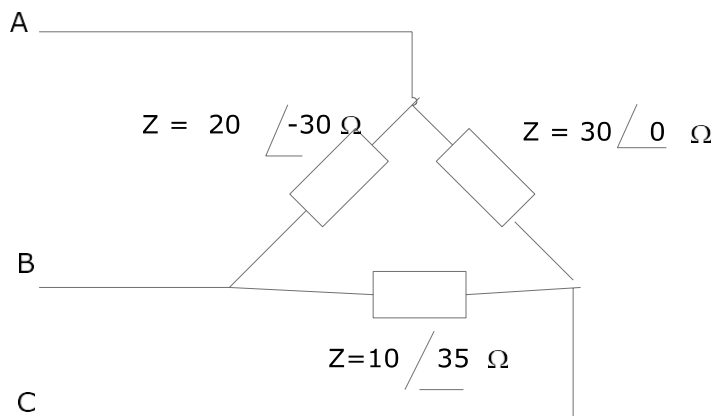
 $Z_a = 20 \angle -30 \Omega$     $Z_b = 30 \angle 0 \Omega$     $Z_c = 10 \angle 35 \Omega$  Voltage 415 V, Sequence ABC

Slide 4+5

Q16. Calculate three phase power for above problem.

Slide 6+7

Q17. If phase sequence is ACB in above problem, find line current &amp; power.

Slide 1+2+3

Q18. Find three phase power.  $V_{ab} = 415 \angle 0$     $I_{AB} = 30 \angle 30$     $V_{BC} = 415 \angle 120$     $I_{BC} = 40 \angle 105$ 
 $V_{CA} = 415 \angle -120$  V    $I_{CA} = 15 \angle -110$  amp

Slide 4+5+6

Q19.  $Z_a = 10 \angle 0^\circ$   $Z_b = 20 \angle 90^\circ$   $Z_c = 25 \angle -70^\circ$  ohm Line voltage = 400 V Find (a) Von (b) Phase voltages (c) Line current

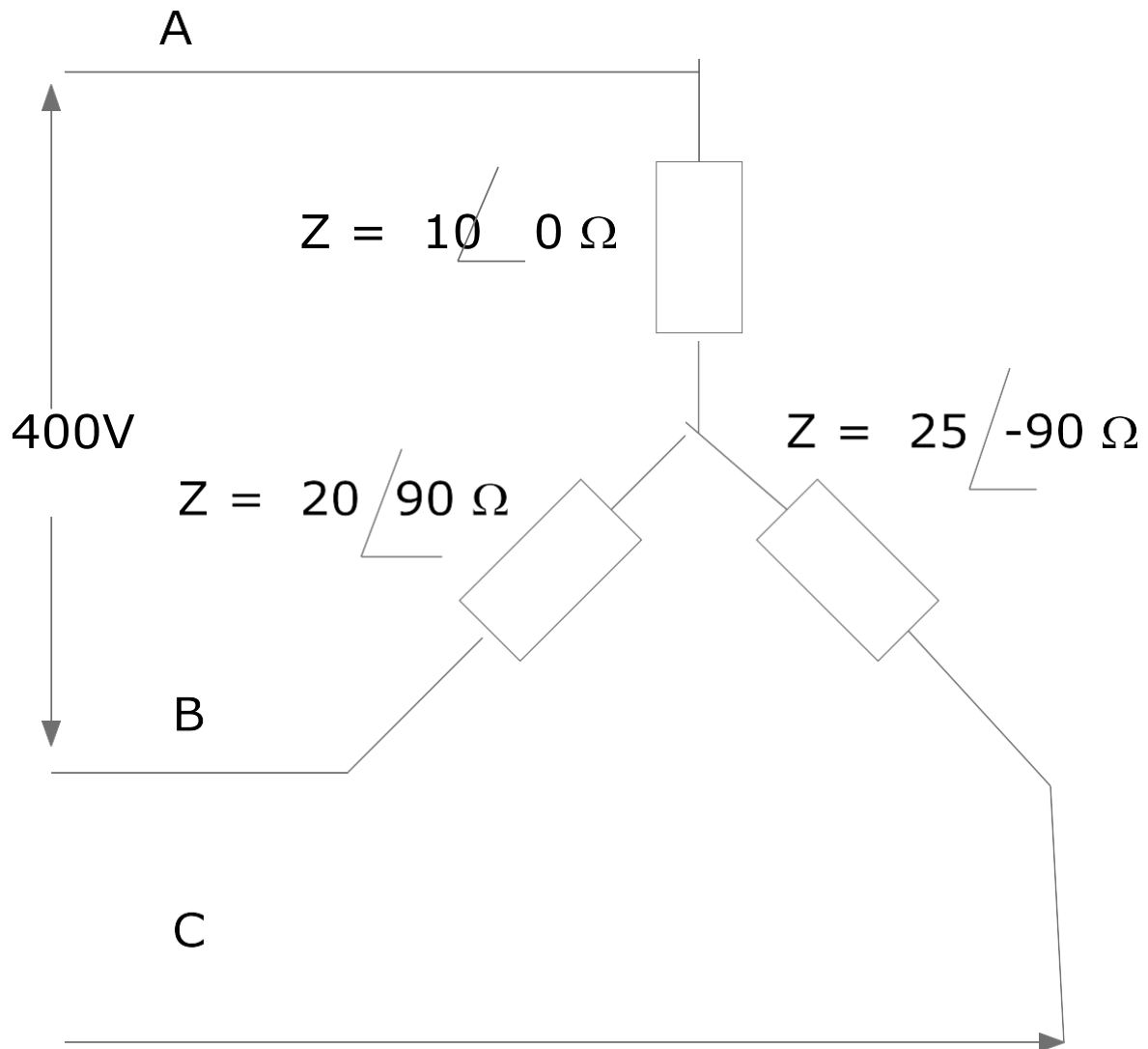

(12) Three phase load

Slide 1+9+10+11

Q20. A 300 V rms , 50 Hz source is supplying the following loads.

Load 1= 4 Kw

Load 2 = 10 KVA, 0.6 PF lagging

Load 3= 4 KVAR leading

Calculate (a) total load (b) total PF (c) the value of additional component to improve PF to 0.97.

Q21.

Study the problems in the following slides 12, 13, 14, 15, 16, 17

G003+G004+G007

(1) Basic wiring circuits + wiring rules

Slide 1

Q1. What are the required topics of background study and electrical wiring rule study for selecting and arranging the equipments for electrical installations?

Slide 2

Q2. Sketch basic wiring circuit to control one switch and light.

Slide 3+4+5

Q3. Sketch a circuit for one switch and socket outlet.

Slide 6

Q4. Sketch light control circuit by timer circuit

Slide 7

Q5. Sketch light dimmer circuit.

Slide 8

Q6. Sketch the typical switch and label the components.

---

(2) Water heaters, switch board wiring, RCD

Slide 1

Q7. What are the special features to be considered for water heater, cooking appliances and motors.

Slide 2+3

Q8. Write an important requirements to install a switch board and main switch board.

Slide 4

Q9. What are the prohibited and restricted locations to install switch board?

Slide 5+6+7+8

Q10. How is the switch board having the exposed live parts installed?

Q11. Describe the switchboard wiring

Slide 9

Q12. Sketch the protective earthing system.

Slide 10

Q13. How can the circuit protection be provided?

Slide 11

Q14. Sketch RCD connection diagram and express the types of RCDs.

---

(3) Earthing+ Wiring system+ safety test.

Slide 1

Q15. Sketch the earthing arrangement diagram. And perform the wiring rule practice provided in the service.

Slide 2

Q16. Sketch the arrangement of earth bar, neutral link and RCD on main switch board.

Slide 3

Q17. Sketch the electrical installation planning for one switch diagram consisting of main switch board, neutral link, earth link and branch circuits.

---

(4) Cable installation

Slide 1+2

Q18. Describe the usage & limitation of TPS wiring system.

Slide 3

Q19. Describe the safety testing procedures before connection to supply.

Slide 4

Q20. Sketch the installation of circular TPS cable on a cable tray.

Slide 5

Q21. Compare ladder & tray.

Slide 6

Q22. What are affecting the actual capacity of cable?

Q23. What are the installation requirements, cable support and weather proof?

Slide 7

Q24. Describe the types of conduits.

Slide 8+9

Q25. What are the installation requirements for conduit?

Slide 10

Q26. Describe the general features of wiring system?

Slide 11+12

Q27. Explain the selection of a suitable wiring system.

Slide 13+14

Q28. Explain (a) open wiring (b) Aerial wire (c) Catenary support.

Slide 15

Q29. Explain trunking system with sketch.

Slide 16+17+18

Q30. Explain cable trays and ladders with sketches.

Slide 19

Q31. Perform wiring rule practices for the tasks given in slides.

Q32. Explain underground wiring system with sketches.

Slide 20+21+22

Q33. What is category A system? Perform wiring rule practices for the tasks given in slides.

-----

(5) Earth fault, Hazard area

Slide 1

Q34. What are the types of earth fault, supply system fault and factors influencing earth fault currents.

Q35. Sketch the installation of earthing system.

Slide 2

Q36. Sketch ELCB system.

Q37. What is MEN system?

Slide 3

Q38. Perform the wiring rule practice tasks described in the slide.

Slide 4+5+6

Q39. What are the causes of earth fault? Perform the wiring rule practice tasks described in the slide.

Q40

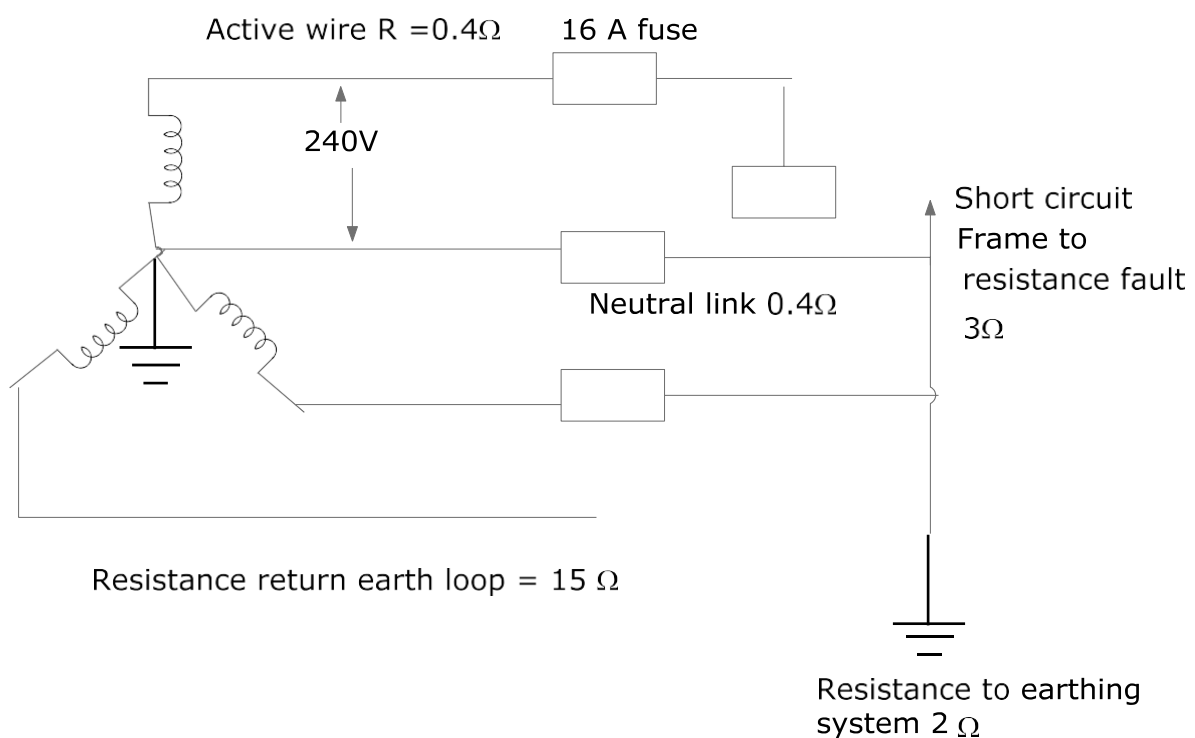

Short circuit frame to resistance fault 3 ohm. Resistance of return earth loop = 15 ohm.

Find the earth fault current in above diagram.

Slide 7

Q41. Sketch the installation of earthing system and write the supplementary system of earth protection.

Q42. How can you isolate live parts?

Slide 8

Q43. What is the meaning of hazardous area and describe types of them.

Slide 9

Q44. What are the types and methods of explosion protection?

Slide 10

Q45. Perform the wiring rule practice described in the slides.

Q46. What are the kinds of equipments and wiring systems that are not permitted in hazardous area?

Slide 11+12

Q48. Sketch the fault current diagram with fuse.

Q49. Perform the performing rule practice described in the slide.

Slide 14+15

Q50. What are the important aspects of electrical installation safety & employees responsibility?

-----

(6) Protection mechanism

Slide 1

Q51. What are the protection mechanism?

Q52. Explain fault current limiters and surge diverters

Slide 2

Q53. How can the switching transient be protected?

Slide 3

Q54. Describe the motor protection methods.



Q55. Sketch the layout of switch board.

Slide 3+4+5

Q56. Describe the switch board installation methods for non domestic electrical installations.

Slide 6

Q57. Perform electrical wiring rule practices described in the slide.

Slide 7+8+9

Q58. Determine the maximum demand of the heaviest loaded phase in a domestic electrical installation comprising

36 lighting points

24 x 10A single socket outlet

2 x 15 A socket outlet

2 x 6.6 KW range

1 x 4 Kw air con unit

1 x 15 kw instantaneous water heater.

3x 5 kw hot plate

Red	White	Blue
2x 15 A socket outlet	10 A socket outlet	36 lights
5 kw hotplate x 1	5 kw hot plate	9 x 10A socket outlet
4 kw air con x 1	5 kw water heater	2 x 6.6 kw oven
5kw water heater	3.6 kw cloth dryer	5 kw water heater.

Slide 10+11

Q59. Determine the maximum demand of the heaviest loaded phase of a block of 85 units comprising the following loads.

Lighting – 85 units

10 A socket outlet = 85 units

Electric range = 17 units

3 KW (13A) permanent strip heater – 85 units.

Quick recovery heater- 85 units.

Loading not associated

100 x 60 w lighting points

24 x 100 w lighting point

(Total lighting 8.4 KW)

21 x 10A single socket outlet

12 x 3.6 kw cloth dryer

3 x 12 kw lift motor

1x 5.5 kw three phase pump motor

1x 3 kw three phase water supply motor

Slide 12

Q60. Sketch the circuit diagram for installation & RCD testing

Slide 13+14+15+16+17

Q61. Explain energy demand metering with sketch.

Slide 18

Q62. What are the installation arrangement for RCD protection.

Slide 18+19

Q63. What are the level of protection required by regulations?

Slide 19+20

Q64. Sketch RCD and explain its operation

Slide 21

Q65. Classify RCD

Slide 22+23+25+26

Q66. Sketch typical installation circuit arrangement.

Slide 24.

Q67. Sketch KWH meter connection for hot water lighting and power.

Slide 27

Q68. Sketch the water heater with twin heat element.

Q69. What are the automatic control methods for hot water system.

Q70. What are the classifications of water heater?

Slide 28+29

Q71. Sketch thermostat connection for hot water heater.

-----

(7) RCD+ Cable selection

Slide 1+2+3+4+5

Q72. Determine the voltage drop for three phase separate final sub circuit and indicate if each result is within SAA limitation. Permissible voltage drop is 15V. Assume all cables are operating at their normal temperature.

- (a) 30 mm<sup>2</sup> copper V75 TPI cable in conduit 35 m 8 amp.
- (b) 3 mm<sup>2</sup> copper V75 SDI cable unenclosed and spaced apart 50 m 30 A.
- (c) 8 mm<sup>2</sup> copper XHF 110 multi-core cable on cable tray 20 m 100 amp.
- (d) 15 mm<sup>2</sup> copper multi-core MIMS cable Pf = 1 5 m 500 amp
- (e) 150mm<sup>2</sup> copper single core MIMS cable 5 m 500 amp
- (f) 75mm<sup>2</sup> aluminium multicore X-90 cable on cable tray 220 m 190 amp

## G003+G004+G007 Part 2

## (1) Cable selection

Slide 1+2

Q1. Write the steps to select cable.

Slide 3+4+5+6

Q2. Draw the cable selection and installation process.

Slide 7 to 15

Q3. Do the exercises for slide 7+8

Slide 15+16+17

Q4. Determine the voltage drop for each 3 phase separate final circuit. Permissible voltage drop is 16V. Assume that all cables are operating at normal voltage.

- (a) 30mm<sup>2</sup> copper V75 TPI cable in conduit 40m , 80A
- (b) 3mm<sup>2</sup> copper V75 SDI cable unenclosed and spaced apart
- (c) 15mm<sup>2</sup> copper X-HF 110 multicore cable on cable tray 20m , 90A
- (d) 12mm<sup>2</sup> copper multicore MIMS cable PF 1 , 35m , 60A
- (e) 180mm<sup>2</sup> single core MIMS cable 4m, 500A.
- (f) 85mm<sup>2</sup> Aluminium multicore X-90 cable on cable tray 150m , 200A
- (g) 3mm<sup>2</sup> copper V75 TPS multicore cable in conduit 25m 20A
- (h) 2mm<sup>2</sup> V90 multicore cable in UG conduit 75m 10A

## (2) Derating factor

Slide 1

Q5. Sketch the block diagram to derate the cable

Slide 2+3

Q6. The maximum demand current of the consumer in a non domestic installation is calculated to be 350A. The selected cable is 4 core non armoured V90 , insulated & sheathed , circular cable with copper conductors . The selected cable is 4 core non armoured V90 insulated & sheathed , circular cable with copper conductors installation of the cable places it clipped directly to un-internal wall open to air & protected binstallation is calculated y CB.

Slide 7+8

Q7. The maximum demand current of the submain in a non domestic installation is calculated to be 150A. The selected cable is 4 cores non armoured V90 insulated and sheathed with copper

conductors. Installation of the cable places it clipped directly to an internal wall with 4 other circuits. All touching open to air & protected by CB.

Slide 9

Q8. The maximum demand current of a submain in a non domestic installation is calculated to be 100A. The selected cable is 4 wire non armoured V90 insulated and sheathed, circular cable with copper conductors. Insulation of the cable tray with other circuits . All touching . The cable tray is suspended 350mm from ceiling open touching & the circuit is protected by CB.

Slide 10

Q9. 4 circuits consisting of 3 cores V90 circular non armoured & sheathed copper conductor cables are bunched together in closed throughing . The throughing is fixed to an internal wall in air horizontal position open air . Each circuit is to carry 60A when protected by CB.

Slide 11

Q10. Three circuits 4 cores of HF 90 TPI circular thermoplastic insulated sheathed non armoured copper conductor cables are buried directly in ground at depth 0.7m where ambient soil temperature of 25°C. The cables are spaced at a distance of 170mm from one another . Each circuit is to carry 130A when protected by CB.

Slide 12+13

Q11. 4 circuits consisting of 3 cores V90 circular non armoured insulated and sheathed copper conductor cables are buried together in closed throughing . The throughing is fixed to internal wall into air . Horizontal position is open to air. Each circuit is to carry 64A when protected by CB.

Slide 14

Q12. A single circuit consisting of 3 single core V90 insulated unsheathed non armoured TPI copper conductor cable enclosed in rigid thermo plastic conduit which is buried in the ground at depth 1.3 m in an ambient soil temperature 25°C. The circuit is to carry 180A when protected by CB.

Slide 15.

Q13. A factory installation by 3 phase 415V supply where by a multiple section installation . The maximum demand is 200A/ph. 3 single core non armoured V90 installed & sheathed circular cable with copper conductors. Installation in rigid thermoplastic conduit buried in ground at soil temperature 28°C. Cables are protected by CB. Calculate maximum conductor size and neutral.

-----

(3) Final subcircuit + Fault loop impedance+RCD

Slide 1

Q14. A final subcircuit supplies a load consisting of a range in domestic installation & is protected by 32A CB . Determine maximum internal fault loop impedance of final subcircuit based on 230V

Slide 2

Q15.A final subcircuit supplies a load consisting of 25A outlet and protected by 25A HRC fuse. Determine the maximum fault loop impedance of final subcircuit & based on 230V.

Slide 3

Q16.A final subcircuit supplies a load consisting of fluorescent lamp and it is protected by a 10A type (C)Circuit breaker . Determine maximum internal fault loop impedance of final subcircuit based on 230V.

Slide 4

Q17.Explain the operation of RCD.

Slide 5

Q18.Classify RCD.

Q19.What are the requirements of RCD?

Q20.Determine the installation arrangements of RCD

Q21.What are the causes of nuisance tripping?

Slide 6

Q22.Explain damp situation.

Slide 7

Q23.Sketch RCD, protected neutral, unprotected neutral.

Slide 8

Q24.Explain the requirements for installation & earthing

Slide 9+10

Q25.Outline safety testing procedures.

---

(4) Circuit testing

Slide 1

Q26.What are to be included in test on installation?

Slide 2

Q27.What are the responsibilities of inspection?

Slide 3

Q28.What are the types of test equipments?

Slide 4+5

Q29.Explain visual examination procedures in circuit checking.

Slide 6

Q30.Explain construction site testing.

Slide 13

Q31.Describe the frequency of inspection and test of all electrical equipments other than fixed equipments.

Slide 14+15

Q32.Describe the earth continuity & resistance testing with sketch.

Slide 16

Q33.What are the required items to be earthed?

Slide 17+18

Q34.Explain insulation resistance testing procedure.

-----

(5) Circuit testing (2)

Slide 1 to 5

Q35.Explain polarity testing.

Slide 6

Q36.

Explain polarity testing of sub-main with sketch.

Slide 7+8+9

Q37.Explain transposition testing with sketch.

Slide 10+11+12

Q38.Explain short circuit testing with sketch.

Slide 13+14+15+16

Q39.Explain interconnection testing with sketch.

G007

(1) Scope + Maximum demand

Slide 1+2

Q1. Express the overview of AS 3000:2007

Slide 3

Q2. Mention the AS 3000:2007 clauses for underground wiring system.

Slide 4

Q3. Sketch catenary system and earthing system.

Slide 5

Q4. Explain the selection and installation of appliances & accessories.

Slide 6+7+8

Q5. Determine the maximum demand of a single domestic electrical installation supplied at single phase with the following loads.

30A lighting points.

15 m lighting track.

8 – 10A single outlet.

10-10A double socket outlet.

1 x 60 w exhaust fan.

1 x 15A socket outlet.

1x 2000w strip heater

1x 15 KW range

1 x 5 KW water heater.

1 x 4 KW tennis court lighting

---

(2) Maximum demand for three phase system.

Slide 1+2+3

Q6. Perform the practice task for the problem in slide 1+2+3

(3) Maximum demand calculation

Slide 1+2+3+4



Q7. Determine the maximum demand of the heaviest loaded phase of a 90 units comprising the following loads.

Lighting – 90 units

10A socket outlet= 90 units

Electric range = 20 units.

2.5 KW (10.4 amp) permanent strip heater = 90 units. Quick recovery water heater = 90 units.

Loading not associated

100 x 60 w lighting points

21 x 100 w lighting points.

20 x 10 A single socket outlet

10 x 4 kw cloth dryer

1 x 5.5 kw three phase pumps

1 x 5 kw three phase water supply motor

-----

(4) Cable selection

Slide 1 to 6

Q8. Calculate the voltage drop in each segment of a three phase 400V non domestic installation consisting of the followings.

**Consumer main**

Three phase maximum demand 50A route length 30m cable size 25mm<sup>2</sup>

Cable configuration- V90 single core thermoplastic and sheathed copper conductors.

Cable Installation

The circuit is enclosed in heavy duty rigid thermoplastic conduit with no other circuits. Conduit is buried in the ground having an ambient soil temperature 25 °C and top cover 0.7m

**Sub main**

Three phase maximum demand 45 A , route length 45 m cable size 25mm<sup>2</sup>

Cable configuration

V90 single core thermoplastic & sheathed copper conductors structure in trefoil formation and installed in single circuit configuration. Unenclosed in air.

**Final sub circuit**

! phase maximum demand 30A route length 40 m cable size 5mm<sup>2</sup>

Cable configuration –V90 two cores and earthed thermoplastic and sheathed copper conductors.

Cable installation

The cables are clipped to the building structure and installed in single conduit configuration . Un-enclosed in air.

Does this portion of the installation comply with voltage drop requirement of AS/NZS 3000?

Slide 7+8+9+10+11

Q9.Perform the practice tasks on slide 10+11+12

-----  
(5)Three phase voltage drop

Slide 1+2+3

Q10. Perform the profile task on slide 1+2+3

Slide 4+5+6

Q11.Calculate voltage drop for a circuit in factory supplying two 15 A socket outlet route 50m protected by 25A CB V 75 TPI cable that is enclosed in air.

Q12.A 50 A three phase boiler is wired using 15 mm V75 TPI cables installed in rigid PVC conduit . The boiler is suited at 70 m from the switch board.

Q13.Six 240V 2000W flood lights outside a factory on a circuit protected by a 32A CB . Circuit cables are V 75 TPI installed enclosed in air route length 76m.

Q14.Two single phase socket outlets installed on a circuit with route length 60 m protected by 32A CB V75 TPI enclosed in air non domestic installation.

-----  
(6) Questions and answers part 1

Slide 1 to 10

Q15.Perform the practice task on questions and answers in slide 1 to 10.

(7) Questions and answers part 2

Slide 1 to 14

Q16.Perform the practice tasks on questions and answers in slide 1 to 14.

G008+G009

(1)AC MACHINE

Slide 1+2+3

Q1.Explain operating principle of AC machine.

Slide 4+5

Q2.Explain operation principle of single phase AC motor

Slide 6

Q3.Sketch universal series motor.

Slide 7

Q4.Sketch the shaded pole motor and explain it's operation.

Slide 8

Q5.How will you reverse (a) Three phase motor )b) Single phase motor.

Slide 9+10

Q6.What are the common faults in motor.

Q7.What are the requirements for motor control equipments?

Slide 11+12

Q8.Sketch DOL starter & explain operation.

Q9.Sketch Star/Delta starter & explain it's operation.

(2) AC Motor control

Slide 1

Q10.Sketch auto transformer starter.

Slide 2

Q11.Sketch primary resistance starter.

Slide 3

Q12.Sketch star / delta starter load characteristics

Slide 4

Q13.Sketch electronic soft start starter.

Slide 5

Q14.Sketch secondary resistance starter.

Slide 6+7

Q15.Explain three phase motor braking method?

Slide 8 to 13

Q16.Explain Plugging?

Slide 9 to 13

Q17.Explain Dynamic braking with sketches.

Slide 14+16

Q18.Explain controlled rectifier , inverter with sketch

Slide 15+17

Q19.Explain motor slip control

Slide 18

Q20.List motor protection systems

-----

(3) Synchronous Machine+ DC Machine + Transformer

Page 1 to 7 Synchronous machine. Do the exercises (Q 1 to 6) on page 6

Page 8 to 15 DC Machine .Do the exercises on page 12 & 13

Page 16 to 32 Transformer. Do the exercises on page 20 & 31

G012

(1) Electrical components + Energy & Power

Slide 1+2

Q1. Indicate the direction of current flow from battery to lamp

Slide 3

Q2. Sketch voltmeter & ammeter connection in circuit.

Slide 4

Q3. Explain the following effect of electrical current (a) Magnetic field (b) Piezo electric effect (c) Chemical effect (d) Heat effect (e) Solar light

Slide 5

Q4. Show the direction of current & magnetic field in (a) Current flowing straight conductor (b) Current flowing coil

Q5. Sketch lead acid battery basic construction diagram

Slide 6+7+8

Q6. What is (a) resistor (b) capacitor (c) inductor (d) semi conductor?

Slide 9

Q7. Define (a) work (b) energy (c) power

Slide 10+11

Q8. Convert 1 kwh to joules

Slide 12

Q9. To move a trolley along a workshop floor through a distance of 100 m, a force of 80 N was required, determine the work-done.

Q10. An electric motor of mass 500 kg was lifted through a height of 10 metres, determine the work-done on the motor.

Slide 13

Q11. The work done by a crane is 180 KJ when a switch board is lifted through a vertical height of 140m. Determine the force required.

Q12. An electrically operated lift is designed to raise a load of mass 1500 kg, a height of 80m in 130 seconds. Calculate the work done in (a) 130 sec (b) 3 sec.

Slide 14

Q13. Write the equations of electrical power.

## Slide 15

Q14. Calculate the power consumed by the light globe. Supply voltage is 240V, current is 0.97 amp.

Q15. Calculate the power consumed by the heater element of 20 ohm supplied by 240V.

## Slide 16

Q16. A motor consumes 12 KW of power when connected to a 240V supply. Calculate motor current.

Q17. A resistance of  $30\Omega$  is connected to a 80V DC supply. Determine (a) circuit current (b) power dissipated by the resistor.

-----

(2) Industrial electrical application + AC DC motor sensor.

## Slide 1

Q18. Show the examples of industrial electrical applications.

Q19. Provide the calculation method for building power consumption.

## Slide 2+3

Q20. Explain the use of sensors in building service .

## Slide 4

Q21. Explain amplifier.

## Slide 5+6

Q22. Describe basic principles of AC power generation with necessary sketches.

## Slide 1

Q23. Show the energy conversion for (a) car engine (b) hydro electric power system.

## Slide 2

Q24. If the process input is 160 KW, output is 155 KW, calculate efficiency.

Q25. What are the sources of energy?

## Slide 3+4

Q26. 3 KW , 240V motor, calculate current. If the wires to motor have a resistance of  $0.2\Omega$ . How much voltage is lost in wires?

Q27. A power station may be providing 200MW along a particular transmission line (a) if the voltage is 240V, find current.

(b) Transmission line has  $0.2\Omega / \text{km}$  and 400 km, what is the voltage drop in line?

(c) If the load voltage is changed from 240V to 100KV, find the ampere & voltage drop in line.

Q28. Sketch AC waveform form and write the equations for  $V_{\text{max}}$  &  $V_{\text{rms}}$ .

Q29. Define period.

Slide 5+6

Q30.

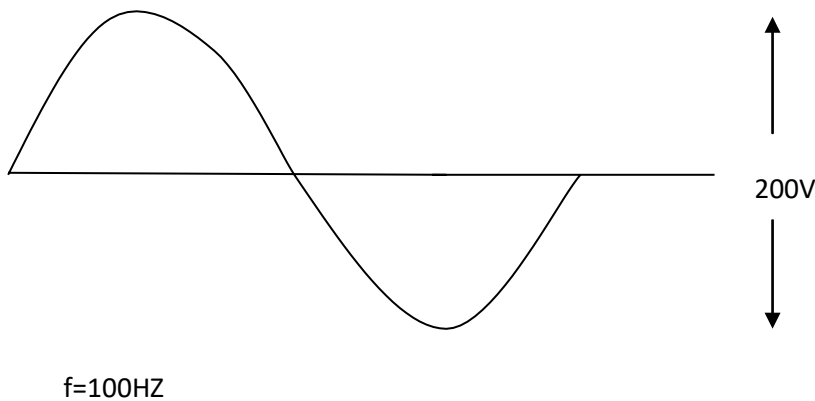

(a) Write the equation for the given wave form.

(b) Calculate period T

(c) Find RMS value of voltage

Slide 6

Q31. Sketch voltage & current waveform & vector diagram for pure resistive load.

Slide 7

Q32. Sketch voltage and current waveform & vector diagram for pure inductance (b) resistor & inductor.

Slide 8

Q33. Sketch voltage & current waveform and vector diagram for pure capacitance

Slide 9

Q34. Sketch voltage and current waveform and vector diagram for resistor and capacitor series circuit.

Slide 10.

Q35. Sketch voltage and current waveform & vector diagram for RLC circuit.

Slide 11+12

Q36. Sketch RLC series circuit and write the equation to calculate the current.

Q37. Write the equation to calculate power.

-----

(4) Transformer, voltage regulation , Inductance, Capacitance, Power, Power factor

Slide 1+5

Q38. What is transformer?

Q39. Sketch the simplified view of power distribution diagram.

Slide 2

Q40. Explain the construction of transformer with necessary sketch.

Slide 3

Q41. A welder needs to have 180 amp output and is to be connected to a 240V , 20A supply . What turn ratio is needed ? What voltage would be supplied to the electrode at output?

Slide 4+6

Q42. A secondary voltage of a transformer is measured as 40V at full load & 40.9 V at no load. What is voltage regulation?

Slide 7

Q43. Sketch series and parallel connection of inductors and write the equation to calculate total inductance.

Slide 8+9+10

Q44. Sketch series and parallel connections of capacitors and write the equation to calculate total capacitance.

Slide 11

Q45. Sketch volt meter, ammeter and watt meter connections for AC circuit.

Slide 12

Q46. Sketch power triangle and indicate real power, reactive power And apparent power.

Q47. Write the equation to calculate power factor.

Slide 13.

Q48. Sketch RL, RC circuit and describe the nature of power factor.

Slide 14.

Q49. For a supply voltage of 240V, 4 KW load, calculate the current needed for  $\phi=0^\circ$  ,  $\phi=30^\circ$  ,  $\phi=75^\circ$  .

Slide 15.

Q50. Describe the effect of power factor on supply current.



-----  
(5) Multiphase system, AC,DC motor, Induction motor

Slide 1+2

Q51.(a)Sketch multiphase supply system and write the equations for  $V_{AB}$ ,  $V_{BC}$ ,  $V_{CA}$

(b)Sketch vector diagram for three phase star system.

(c)Express the phase and line voltages.

Slide 4+5

Q52.Sketch delta connection.

Q53.Draw the delta connection of three phase on its terminal block.

Slide 4+5

Q54.Describe the principle of operation of dc motor.

Slide 6+7

Q55.Sketch (a) series motor (b) short shunt compound motor (c) long shunt compound motor

Slide 8+9

Q56.What are the applications of the following dc motors.

(a) DC compound motor

(b) DC series motor

(c) DC shunt motor

(d) DC compound motor

(e) Universal motor

Q57.How will you reverse the direction of rotation of dc shunt motor?

Slide 10+11

Q58.Sketch the physical diagram of three phase squirrel cage induction motor and explain its construction and operation.

Slide 12.

Q59.Sketch the connection of the poles of three phase 4 poles motor.

Q60.A three phase 4 poles motor is connected to 50HZ, calculate the speed.

Slide 13+14

Q61.Calculate the speed in RPM if frequency is 25HZ for 2 poles motor

Q62.The measured speed of three phase 415V 50HZ , 2 poles motor is 2700 rpm. Calculate slip speed and % slip.

Slide 15.

Q63.What is starting characteristics of three phase induction motor.

Q64.Sketch the connection diagram of three phase induction motor to reverse the rotation.

Q65.Write down the reduced voltage starting methods for three phase induction motor.

Slide 16.

Q66.What are the typical values of PF of three phase induction motor?

.....-

(6)Motor starting, wound rotor motor, motor construction

Slide 1+2+4

Q67.Sketch (a) Direct online starter (b) Primary resistance starter (c)Forward reverse starter

Slide 3+5

Q68.Sketch wound rotor motor.

Slide 6

Q69.Explain the operation principle of synchronous motor with sketch.

Slide 7

Q70.Describe the general features of the construction of electric motor in the following aspects

(a) Open (b)Drip proof (c) Wounded (d) Class A (e)Class B (f)Class C (g) Class D

Slide 8

Q71.Sketch (a) Split phase motor (b) Capacitor start motor (c) Capacitor start capacitor run motor

Slide 9

Q72.What are the starting torque, speed regulation , speed control , reversal methods and application of (a) DC shunt motor (b) Squirrel cage induction motor (c) Wound rotor motor.

Slide 10

Q73.A motor runs at the rating 60 HP for 20 sec, 200HP for 10 sec ,230HP for 35 sec, No load for 10 sec Calculate the average power rating of motor.

G015 (AA)

(1) OH Line mechanical design

Slide 1+2+3+4

Q1. 15m pole set 3m in ground with three No 4/0 standard copper conductors on a cross arm with conductor level at the top of pole and 50m balance of span in a heavy loading area. Pole got 22 cm at top and 33 cm at bottom. The moment due to wind on conductors when ice coated is as follows. No 4/0 stranded copper wire of 1.5 cm allow 2.8 cm of ice for a unit diameter of 4 cm area to wind. Calculate total moment of inertia and pole circumference required.

---

(2) Sag calculation

Slide 1+2+3

Q2. Perform the exercises for 4.cise for review questions on slide

Q3. The conductor to be erected over 180 m span has equivalent weight 5N/m diameter 15mm and ultimate tensile strength 38KN. Determine the sag if wind loading is 600 Pa and safety factor 4.

---

(3) Sag calculation + % Ultimate strength

Q4. 15m pole is installed with three No 4/0 bare conductors in one direction and three No 2/0 bare stranded copper conductors in opposite direction. Three No 4/0 conductors cause 1400017 N-m bending moment and three No 2/0 conductors cause 1173731 N-m bending moment wind load on pole is 13000 N-m. Calculate tower circumference to withstand the load if long leaf yellow pine ultimate stress  $51.3 \times 10^6$  is used. Take safety factor 2.5.

---

(4) Stay –Guy wire design

Slide 1+2+3+4+5

Q5. Three No 4 medium hard drawn copper primary conductor is attached at 12 m above the ground on pole. Four No 2 soft drawn copper is attached at 2.5 m below on pole. A pole face area to wind is  $2.8 \text{ m}^2$  and wind pressure is 198 Pascal at 7.5 m. The guy wire is attached At 9.5 m above the ground at  $40^\circ$ . Calculate the horizontal and vertical loading on guy wire. No 4 wire was 400 Kg weight for No 2 wire has 460 kg weight for the span. If allowable stress in guy wire is  $34 \times 10^6 \text{ N/ m}^2$ . Calculate the diameter of guy wire.

---

(5) Cross arm design + Assembly+ Pin & Bolt design

Slide 1+2+3

Q6.

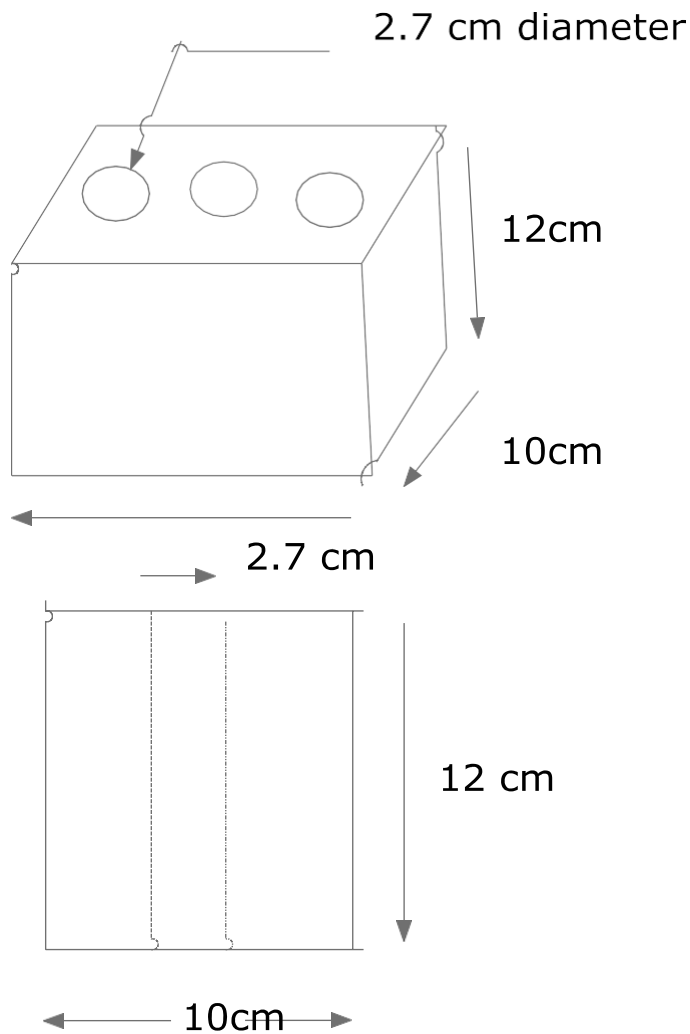

In above cross arm, total moment of inertia on cross arm is 500 N-m. Calculate the stress of the cross arm material

Slide4+5+6+7+8

Q7.13 m pole set in 2m in ground with three No 4/0 stranded copper conductors on cross arm with conductor level and 47 m span in heavy loading area.

Pole got 22 cm at top and 32 cm at bottom. The moment of inertia due to wind on conductor when ice coated is as follows.

No 4/0 copper wire of 1.5 cm diameter 2.8 cm thickness of ice. Calculate (a) total moment of inertia  
(b) Maximum fibre stress.

(6) Pole & line installation technique

Slide 1

Q8.Describe pole and line installation techniques.

Q9.Sketch line profile diagram.

Slide 2

Q10.What are the requirement for line planning?

Q11.What are the scales to be utilized for preparing line design drawing.

---

(7) Line deviation , Galvanizing + Current rating +UG cable

Slide 1

Q12.What is line deviation?

Q13.Write the equation to calculate the resultant force on pin.

Slide 2

Q14.Write the methods to do the protection against corrosion for line tower.

Q15.Can the pin insulation be used for termination of pole?

Slide 3

Q16.Determine the maximum deviation allowed on 11KN pin insulator for a 7/3.50 hard drawn copper conductor with a span of 180 m .The ultimate strength of he conductor is 27000N. The wind load is to be taken as 550Pa and the diameter of conductor is 10mm. Tension in conductor must not be more than 60% of ultimate strength. Transverse loading on pin insulator is not to exceed 45% of ultimate strength.

Slide 4

Q17.Wat are the standards for (a) Loading condition (b) Aerial conductor (c)Sag & tension (d)Foundation

Slide 5

Q18.Write down the methods and requirement for staying of pole and support.

Slide 6

Q19.Sketch the diagram for essential components of staying pole.

Slide 7

Q20.What are the requirement of conductor size and separation of conductors?

Slide 8

Q21.Show the table for span & spacing relationship

Slide 9

Q22.Do the review question exercises.

Slide 10

Q23.What are the methods to reduce the stress in UG cable?

## Line survey &amp; line design

Study slides 1 to 14 and perform the given line design.

---

## (8) Stress in UG cable

Slide 1

Q24. How will you reduce the stress in UG cable laying?

Slide 2+3

Q25. What are the causes of stress in UG cable & write the equation to calculate stress.

Slide 4+ 5+6+7+8+9

Q26. A single core 66KV cable has a conductor of 2.5 cm & sheathed inside diameter 6 cm. Find the maximum stress if two inter-sheaths are used. Find the best position, the maximum stress and the voltage on inter-sheaths.

Slide 10

Q27. Explain sheath current

---

## (9) UG cable capacitances, testing, connection

Slide 1+2

Q28. Sketch the UG cable & indicate capacitance. Express the equation to calculate capacitance.

Slide 3+4

Q29. A single core 66KV cable has a conductor diameter of 2.5 cm and sheath inside diameter 6 cm. Find the maximum stress if two inter-sheaths are used. Find the best position. The maximum stress & the voltage on inter sheaths.

Slide 5

Q30. In testing of UG cable, conductor 2 & 3 are connected. By measurement of capacitance between conductor 1 and 2-3 combination is 7  $\mu\text{F}$ . When all conductors are connected, the measured capacitance is 5  $\mu\text{F}$ . Calculate the capacitance between conductors & the capacitance between conductor & sheath.

---

## (10) Decision strength and fault in UG cable

Slide 1+2+3

Q31. Conductor insulation thickness = 0.52 cm, dielectric constant = 4, Belt thickness = 0.45 cm, Conductor diameter = 1.7 cm. Calculate the capacitance to neutral for 1.5Km long cable.

Slide 4

Q32.Explain UG cable fault finding methods.

---

(11) Voltage regulation & booster transformer

Slide 1

Q33.Write down the formula to calculate regulation for line.

Q34.Sketch the diagram of voltage regulator.

---

(12) Booster transformer

Slide 1+2

Q36.Sketch the diagram of booster transformer and write down the equation.

Q37.Sketch the induction & moving coil regulators.

Slide 3

Q38.Describe the voltage control method.

Q39.Write the equation to calculate the power line.

Slide 4

Q40.Describe the causes and effects of voltage regulation.

Slide 5

Q41.State three general methods of voltage control.

Q42.List five voltage control devices in distribution system.

Slide 6

Q43.What is voltage profile chart ?

Slide 7

Q44.For given single line diagram, plot the voltage profile for heavy load period. Voltage at point A is 120%

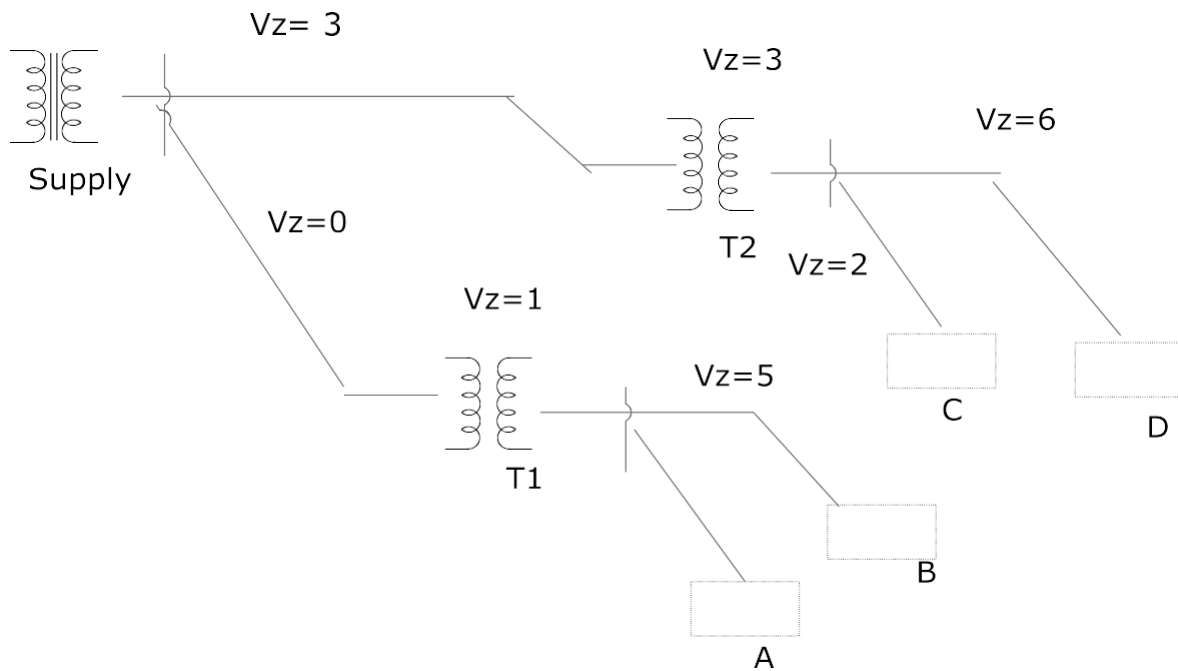

(13) UG cable infrastructure

Slide 1+2

Q45. What are the UG cable installation methods, explain them with necessary diagrams.

Slide 3

Q46. Find installation resistance per Km of cable of conductor diameter 1.8 cm & internal sheath diameter 5.2 cm.

Q47. In above problem if cable is subject to 132 KV. Find dielectric loss

Slide 4

Q48. Sketch cable ducts.

Slide 5

Q49. Sketch service boxes.

Slide 6

Q50. Wheel load 10,000 kg, impact 45% for heavy travelled street over which traffic may be concentrated. Wheel is 16 cm x 32 cm. Calculate concentric load on man-hole cover.

Slide 7

Q51. Explain (a) Roof (b) Wall (c) Floor (d) Frame cover (e) Ventilation

G015 (AE)

(15) Over current and earth fault protection



Slide 1+2

Q1.Sketch three phase over current protection.

Q2.Sketch three phase earth fault relay protection.

Slide 3+4+5

Q3.Explain the operation of directional element with sketch.

Slide 6

Q4.Locate the position of reverse power relay in power line.

Slide 7

Q5.Sketch the connection of combined protection scheme that contains two over current relays & one earth fault relay to provide phase to phase and earth protection.

Q6.How does directional element of relay perform?

Slide 8

Q7.Locate directional and non directional element in a ring circuit.

Slide 9+10+11+12

Q8.Explain time grading system.

---

(16)Time & current grading

Slide 1

Q9.Explain time and current protection with sketch

---

(17) Power transformer protection

Slide 1+3

Q10.What are the types of faults in power transformer?

Slide 2

Q11.Wat are the causes of transformer faults.

Slide 4+5

Q12.Explain differential relay protection for power transformer with sketches.

Slide 6

Q13.Sketch the connection of differential relay.

Slide 7

Q14. Sketch the diagram to provide earth fault & differential protection for three phase star/ delta transformer.

Slide 8

Q15. Sketch the vector diagram for primary and secondary main winding of star/ delta power transformer.

---

(18) Connection of differential relay

Slide 1+2

Q16. Sketch the connection of differential relay and explain the operation.

---

(19) Three phase differential relay

Slide 1

Q17. Sketch three phase star/ delta transformer protection with differential relay.

Slide 2

Q18. Explain the setting of differential relay.

---

(20) Connection of main transformer, CT , directional relay

Slide 1+2+3

Q19. Sketch the combined earth fault and differential protection for three phase star/ delta transformer.

---

(21) Definite minimum time point, interpreting relay specification

Slide 1+2

Q20. How will you adjust the definite minimum time point on relay curve?

Q21. Explain the operating characteristics of following relay

10 amp 150/40/200

---

(22) Capacitor bank protection

Slide 1

Q22. Sketch the diagram for capacitor bank and earth fault protection.

---

(23) Transmission line protection

Slide 1

Q23. Sketch transmission line differential protection

Slide 2+3

Q24. Sketch the modification diagram for transmission line protection with differential relay.

---

(24) Distance relay, pilot wire with differential three phase line protection

Slide 1

Q25. Explain the operation of distance relay

Slide 2

Q26. Explain the operation of distance relay with sketch

Slide 3+4

Q27. Sketch the characteristics curve of distance relay

Slide 5+6

Q28. Explain the zone protection of distance relay.

Slide 7+8

Q29. Sketch the protection diagram of distance relay with operating & restraining voltage and current.

---

(25) Distance protection scheme

Slide 1

Q30. Explain the distance protection scheme with sketch.

Slide 2

Q31. Explain the operation and construction of distance relay with sketch.

Slide 3

Q32. Explain the characteristics of distance relay.

Slide 4

Q33. Describe the directional distance relay with sketch.

Slide 5

Q34. What is the relation between maximum reach & relay characteristics.

Slide 6+7

Q35.Explain the zones for distance protection scheme.

Slide 8

Q36.Explain the operation of three phase distance relay.

Slide 9

Q37.Explain maximum reach and maximum reach angle.

---

(26) Protective transformer

Slide 1+2

Q38.Write the transformer voltage equation.

Slide 3

Q39.Explain the effect of magnetizing and hysteresis loss.

Slide 4

Q40.Explain the application of balancing winding in CT with sketch.

Slide 5

Q41.Write the equation for % composite error.

Q42.Explain the following specification

0.05 PL 950 R3

Slide 6+7

Q43.What is protective transformer?

Q44.For what reason, the balancing winding is inserted into CT secondary winding.

Slide 8

Q45.Explain 20 P 250 F30

---

(27) CT Characteristics

Slide 1

Q46.Explain (a) current transformer (b) potential transformer (c)power transformer

Slide 2

Q47.Explain burden impedance effect.

Slide 3

Q48. Interpret 10P 150 F15

Q49. Interpret 0.05 PL 950 R3

-----  
(28) Multi tapped CT, CT calculation , Testing CT

Slide 1+2

Q50. For 4000/2000/100/1 CT 10P300 is classified at 4000/ 1 winding. What will be the classification for 2000/1, 100/1 windings.

Slide 3+4

Q51. For 500/1 20P 250 CT secondary dc resistance is  $2\Omega$ . Calculate (a) Burden resistance (b) Excitation current (c) Secondary voltage (d) class voltage (e) Declared maximum ratio error

Slide 5

Q52. Explain (a) AC ratio check (b) DC polarity check (c) Three phase polarity test for three phase CT

Slide 6

Q53. How will you interpose & sum CT & PT?

(29) Digital relay+ Telecommunication for protection

Slide 1

Q54. What is digital relay?

Slide 2+4

Q55. Sketch the flow diagram of digital relay operation.

Slide 3+4

Q56. Sketch DAC system

Slide 5

Q57. Explain busbar protection with sketch

Slide 6

Q58. Write line & busbar protection with sketch.

Slide 7

Q59. Sketch the operation of digital relay.

Slide 8+9

Q60. Sketch the flow chart for the software of digital protective relay.

Slide 10

Q61.Explain the application of telecommunication network in power system protection.

---

(30) Typical control power installation diagram

Slide 1 to 3

Q62.Take the drawing practice on diagram.

---

(31) Three phase control diagram + comparator

Slide 1+2

Q63.Draw the directional element integration of distance relay protection

---

(32)Over current & earth fault protection , Directional protection, operating characteristics

Slide 1

Q64.Sketch the diagram of over current protection

Slide 2

Q65.Sketch earth fault relay protection diagram.

Slide 3

Q66.Sketch the combined over current and earth fault protection and explain it's operation.

Slide 4

Q67.Explain the operation of directional relay with diagram.

Slide 5+6+7+8

Q68.Locate directional & non directional elements in ring system.

Slide 9+10

Q69.Sketch the connection diagram of combinational protection scheme that contains two over current relays and one earth fault relay to provide phase to phase and phase to earth protection.

Slide 11

Q70.How will you adjust definite minimum time point on relay curve?

Slide 12+13+14+15+16+17

Q71.Sketch the curve for discrimination by both time & current of the following power.

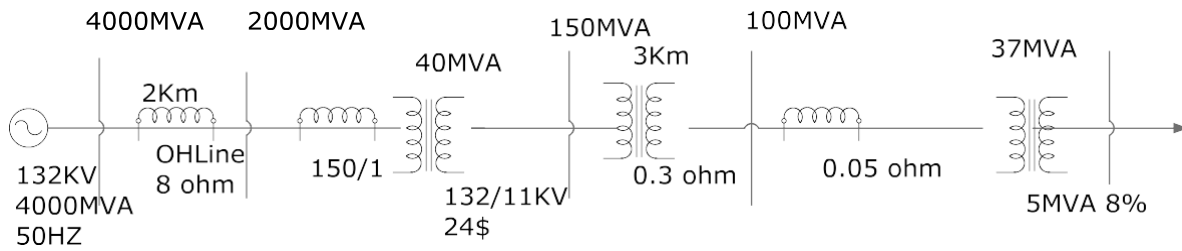

G015(AG)

(33) Alternator supply load

Slide 1+2

Q1. Generator A with 100MW, 4% drop and generator B of 200 MW 4% drop. Are supplying the 200MW load. Calculate their load share.

Slide 3+4

Q2. Generator A with 200MW 6% drop and generator B with 400MW 7% drop are supplying 300MW load, calculate their load share.

(34) Stability

Slide 1+2+3+4+5+6+8+9+10+11

Q3. A generator operating at 50HZ delivers 1 pu power to infinite busbar through network in which resistance may be neglected. A fault occurs which reduces the machine power transferable to 0.4pu whereas before the fault. This power was 1.8 pu and after the clearance of the fault, this power was 1.8 pu and after the clearance of the fault, it is 1.3 pu. By use of equal area criterion, determine the critical clearing angle.

Slide 7

Q4. Write the machine angular acceleration formula.

(35) Corona+ short circuit current+ Transient fault + voltage surge+ Reflection

Slide 1

Q5. What is corona?

Q6. Explain the concept of disruptive critical voltage.

Slide 2+3

Q7. How does corona happen? And express the factors related to occurrence of corona.

Slide 4

Q8. Write the formula to calculate break down voltage

Slide 5

Q9. What are the disadvantages of corona?

Slide 6+7

Q10. What are to be done to prevent the corona?

Slide 8

Q11. Sketch the short circuit current in AC network.

Slide 10

Q12. Sketch the connection of current limiting reactor.

Slide 11

Q13. Sketch the power response by line voltage surge graph.

Slide 12

Q14. What are the causes of voltage surge?

Q15. Write the equation for switching e.m.f velocity.

Slide 13

Q16. Sketch voltage surge & protection diagram .

Slide 14+15+16

Q17. A transmission line has  $0.015 \mu\text{F}$  capacitance and  $3 \text{ nH}$  inductance . It is joined with a cable of  $0.4 \mu\text{F}$  capacitance &  $0.3 \text{ mH}$  inductance. Calculate (a) Natural impedance of OH line. (b) Natural impedance of UG cable (c) Reflected crest voltage (d) Maximum voltage at junction.

Slide 17

Q18. 12 KV line with  $800 \Omega$ . Is connected to  $200 \Omega$  and  $300 \Omega$  lines.

Calculate (a) Reflected voltage (b) Maximum voltage at junction (c) Maximum current in brunch & main line .

---

(36) Reactive power control static VAR compensation

Slide 1+2+3

Q19. How will you connect the reactive power control capacitor bank to three phase system.

Q20. Sketch synchronous motor reactive power control diagram.

Q21. Explain how reactive power is controlled by static VAR compensation system.

---

(37) Line power flow receiving end voltage comparison.



Slide 1+2

Q22.

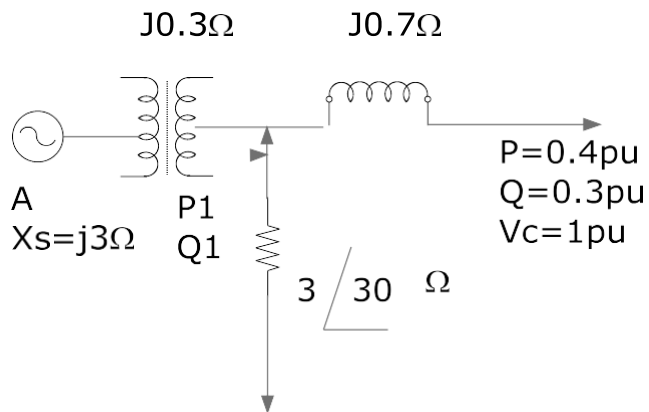

Calculate (a)  $V_A$  (b) current flow to  $Z$

-----

(38) Computerised control + Supervisory control+ IP based network + Digital control

Slide 1

Q23. Explain the application of telecom system in power line with sketch.

Slide 2+4+5

Q24. Explain telecom based differential protection system.

Slide 6

Q25. Explain distributed real time computer network for power system.

Slide 7+8+9

Q26. Explain remote and computer control in power system.

Slide 10.

Q27. Why is phase comparison relaying provided?

Q28. Sketch ADC control.

Slide 11+12+13+14

Q29. Sketch internal & external fault discrimination diagram.

Slide 15+16

Q30. Explain the application of computerised control and power network.

Slide 17.

Q31. Explain power line communication system.

Slide 18

Q32.How is telecommunication applied in power system?

Slide 19

Q33.Explain component of electronic control system for power line.

Slide 20

Q34.Explain digital signal processing sub system for computer control power system operation.

Slide 21

Q35.Sketch the typical protection scheme

Slide 22

Q36.Sketch the computer flow chart for power system protection.

Slide 23

Q37.Sketch electronic control system for power system protection.

-----  
(39) Metering + Location of CT+ Power Surge +Grounding +Harmonic

Slide 1

Q38.Sketch the basic metering arrangement in substation.

Slide 9

Q39.Sketch the location of CT in power line

Slide 10

Q40.Explain power surge protection for transmission line.

Slide 11+12

Q41.Explain grounding in power system.

Slide 13+14+15

Q42.A square wave has amplitude of 70V , fundamental is 90V. Calculate (a) Effective value of square wave. (b) Effective value of fundamental (c) Total harmonic distortion

Slide 6

Q43.Sketch the diagram of harmonic filter.

-----  
(40) Power system economic +Synchroscope+ Fuel cell +RAP

Slide 1+2+3

Q44.Describe producer & consumer's behaviour.

Slide 4

Q45. Sketch (a) Arcing horn (b) Lightning arrester (c) Surge absorber

Slide 5

Q46. Sketch the arrangement of instrument in sub station.

G040

(1) Transformer construction

Slide 1

Q1. Sketch shell & core type transformer constructions.

Q2. Write the transformer voltage equation.

Q3. Write voltage, current and turn relations of transformer.

Slide 2

Q4. Calculate iron core flux density & RMS magnetizing current for the following single phase transformer.

$N_p=500$   $E_p=2000V$  (RMS), Core CSA = 100 sq-cm where length = 200 cm Air gap 0.5mm,  $\mu_0= 1900$

Slide 3+4

Q5. Describe transformer cooling.

Q6. How will you check the polarity to operate transformers in parallel.

Q7. Transformer A, rated 10MVA,  $\%Z_a = 1+j2\%$

Transformer B, rated 20MVA  $\%Z_b = 2+j3\%$

(a) Calculate  $\%Z$  of 20MVA transformer based on 10MVA.

(b) MVA supplied by each transformer when they are supplying 15MVA unity PF.

Slide 5

Transformer equivalent circuit.

Q8. Write the equations to do transformer open circuit and short circuit tests.

Slide 6

Q9. Describe power flow diagram in transformer.

Slide 7

Q10. The followings are test results of three phase 66/11KV 40MVA Star/Star transformer.

No load test

LV side= 11KV LV side current = 60 amp, power 30KW

Short circuit test

Line voltage = 1700V Line to line current = rated current. Power = 30KW

Calculate  $R_{h+e}$ ,  $X_m$ ,  $R_e$ ,  $X_e$

Slide 8

Q11. In the following diagram, (a) Find iron loss (b) secondary load current (c) copper loss (d) load power (e) Efficiency

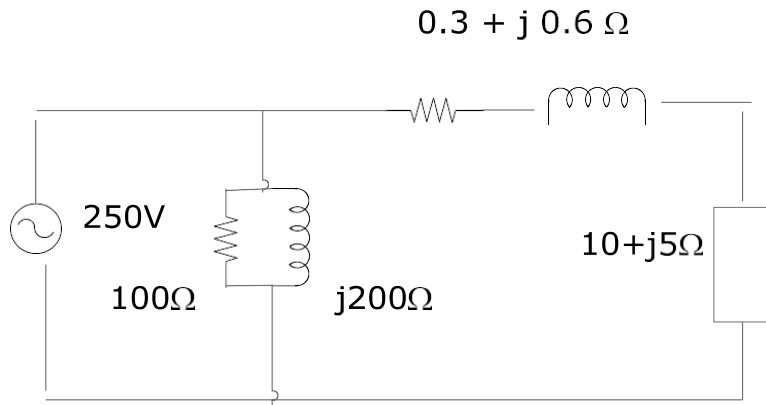

Slide 9+10

Q12. A 2000KVA 6600/415V three phase delta/ star transformer %R = 2.8, %X = 6 Maximum efficiency occurs at one third load. Calculate (a) Iron loss (b) Maximum efficiency at 0.9 power factor.

Slide 11

Q13. Sketch auto transformer and write VA equation.

Slide 12

Q14. 600/300 V 2 windings transformer single phase rated 10KVA. The transformer is to supply 900/ 200 V. Draw the circuit how to supply the load. Also find it's rating while supplying 900/200V.

(2) Power transformer + magnetisation

Slide 1+2+3

Q15. Sketch the location of power transformers in power line.

Slide 4+5+6

Q16. Explain the relationship between magnetisation and transformer voltage.

Slide 7+8

Q17. Explain (a) Permeability (b) Flux density (c) Magnetisation flux

Slide 9+10+11+12+13+14

Q18. Sketch –core type & shell type laminated iron core

Q19. Do the exercise on slide 11.

Slide 15

Q20. Explain transformer rating.

Slide 16+17+18

Q21. What are the requirements for parallel operation of power transformer.

Slide 19

Q22(A). What is per unit rating of power transformer.

Slide 20

Q22(B). Primary turn = 400

Primary voltage = 2400V rms

Frequency = 50HZ

CSA = 300 cm<sup>2</sup>, length of winding = 130 cm. Calculate the magnetic flux density of above single phase transformer.

Q23.

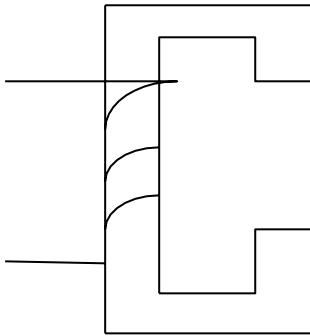

Core length = 1300 mm Air gap length = 0.2 mm Magnetic flux density = 1.2T,  $\mu_r$  steel=2000

$$\mu_o = 4 \pi \times 10^{-7}$$

Calculate (a) total magnetizing force (b) If number of turns on core is 400, calculate I max, I rms.

Slide 23

Q24(a) .Sketch Buchholz relay and explain its operation

Slide 24

Q24(b) .Derive the E rms equation.

-----

(3) Transformer equivalent circuit

Slide 1+2

Q25. Explain the principle of operation of power transformer.

Slide 9

Q26. Find primary and secondary current of 5KVA 300/150V single phase transformer.

Slide 10+11

Q27. Explain power losses in transformer

Slide 12+13

Q28.

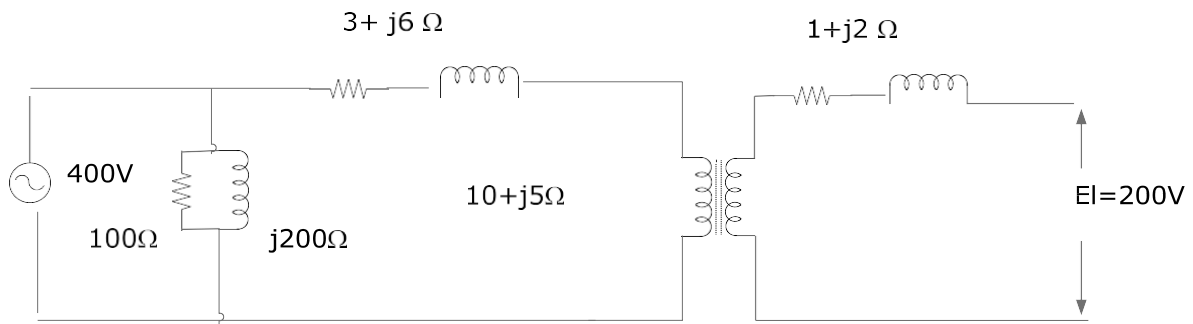

In above circuit, calculate

- Secondary reactance referred to primary
- Secondary inductive reactance referred to primary
- Total equivalent resistance referred to primary
- Total equivalent inductive reactance referred to primary
- Primary current
- Draw a simplified equivalent circuit diagram.

Slide 14+15+16

Q29.

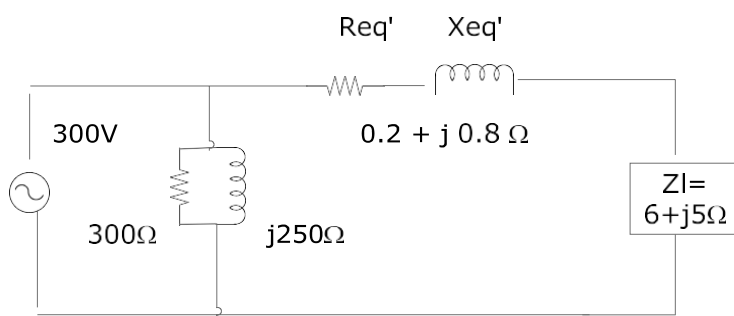

Calculate

- Iron loss
- No load current
- Secondary load current
- Total primary current

- (e) Copper loss
  - (f) Power consumed by load
  - (g) Efficiency of given circuit.
- 

#### (4) Polarity testing

Slide 3+4+5+6+7

Q30. Sketch transformer equivalent circuit and label the components & write the formula

Slide 8

Q31. Do the exercises on slide 8

Slide 9

Q32. Do the exercises on slide 9

Slide 10.

Q33. Explain the power loss in transformer.

Slide 11+12+13+14+15

Q34. In the following transformer

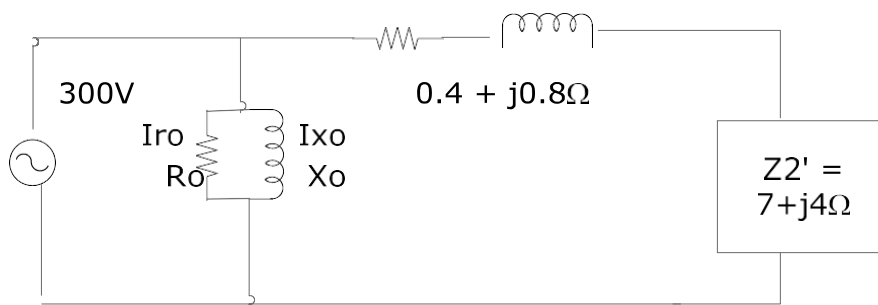

Find

- (a) Iron loss
- (b) No load current
- (c) Secondary load current
- (d) Total primary current
- (e) Copper losses
- (f) Secondary terminal voltage
- (g) Power in watt consumed by load
- (h) % efficiency.

Slide 16+17+18

Q35. Explain transformer open circuit test and short circuit test with the sketches

Slide 19+20+21

Q36. Do the exercises on slide 19

Slide 22+23



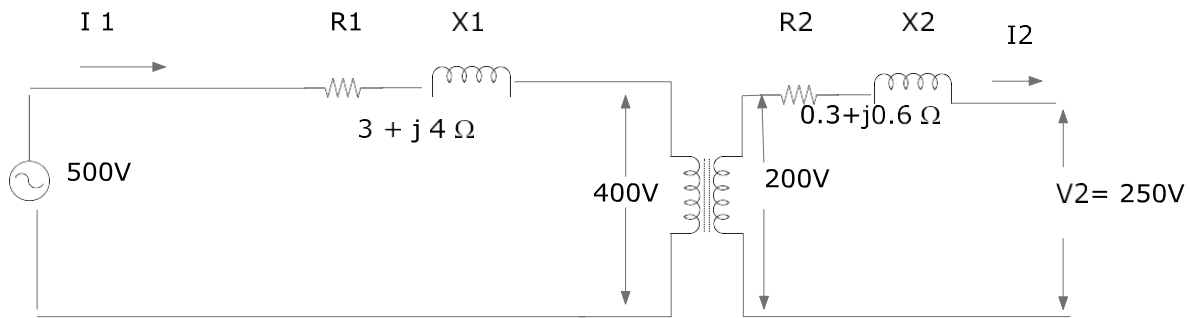

Find (a)  $a$  (b)  $Z_1$  (c)  $I_1$  (d)  $Z_e$  (e)  $I_2$

---

(5) Transformer losses + Voltage regulation

Slide 1

Q37. Write the equation of % voltage regulation.

Slide 2

Q38.  $\%R = 3$ ,  $\%X = 6$  Find % voltage regulation at 0.9 PF lagging

Slide 3+4+5

Q39.  $N_p = 500$ ,  $N_s = 100$ ,  $R_p = 0.2 \Omega$ ,  $R_s = 0.015 \Omega$ ,  $X_p = 0.1 \Omega$ ,  $X_s = 0.4 \Omega$ ,  $V_p = 2000V$ ,  $V_s = 500V$

Find  $Z_{eq}'$ ,  $V_s'$ , % Regulation for 0.9 PF lagging, % Regulation for 0.95 PF leading

Q40. Write the equation for % regulation at maximum efficiency.

Slide 6

Q41. If  $\%R = 4$   $\%X = 6$  Find % Regulation at PF lagging.

Slide 7

Q42. Write the equation for transformer loss and efficiency.

Slide 8+9

Q43. Single phase 6000KVA transformer 7000/450V Iron loss = 3 KW, Full load copper loss 5 KW. Find (a) % Efficiency at full load 0.9 pF lagging (b) % Efficiency at half load 0.9 PF lagging.

Slide 10+11

Q44. Find the load at maximum efficiency of the following single phase transformer. KVA = 2000, Voltage ratio = 7000/500, Iron loss = 5 KW, Full load copper loss = 7KW, Maximum efficiency is achieved at 0.7 PF lagging.

---

(6) Parallel operation

Slide 1+2

Q45. 600KVA Three phase transformer , voltage ratio 6600/440V Iron loss = 3 KW, Full load copper loss = 5KW. Find % efficiency for

- (a) Full load 0.7 PF lagging
- (b) Half load 0.9 PF lagging
- (c) 1/3 load 0.707 PF lagging

Slide 3+4

Q46. Write % Regulation equation & vector diagram

Slide 5+6+7+8

Q47. 200KVA three phase transformer ,  $N_p=500$ ,  $N_s=100$ ,  $R_p=0.2\Omega$ ,  $R_s=0.02\Omega$ ,  $X_p=2\Omega$ ,  $X_s=0.04\Omega$

$V_p=2300V$   $V_s=450V$  Find (a)  $Z_{eq}'$  (b)  $V_s'$  (c) % Regulation PF 0.9 lagging & 0.8 lagging

Slide 9

Q48. Write the conditions required for transformer parallel operation.

Slide 10+11+12+13+14

Q49. 1000KW PF 0.9 Lagging is supplied by two transformers connected in parallel.

Tr A = 1000KVA  $Z_a=4+j6$  ohm

Tr B=1000KVA  $Z_b=1+j3$  ohm

Find load share of each transformer.

Q50. 2000KW load PF 0.9 lagging is supplied by two transformers connected in parallel.

Tr A = 2000KVA  $Z = 3+j2$  ohm

TrB =1000KVA  $X=3+j5$  ohm

Find load on each transformer

-----

(7) Three phase transformer connection

Q51. Sketch  $Y_0$ ,  $Dd_0$ ,  $Dz_0$ ,  $Y_6$ ,  $Dy_1$ ,  $Yd_1$ ,  $Dy_{11}$ ,  $Yd_{11}$

Slide 7+8+9+10+11+12+13+14+15+16+17

Q52. Write the applications of the following transformer connections

- (a)  $Y_0 - Y_6$
- (b)  $Dd_0 - Dd_6$
- (c)  $Dy_1 - Yd_1$
- (d)  $Dy_{11} - Yd_{11}$

Q53.Connect

- (a) Tr1 = Dy 11 & Tr2 Dy1
- (b) Tr1=Yy0 & Tr2 = Dd0
- (c) Tr1=Dy11 & Tr2 = Yd11

(8) Transformer problems-Auto transformer

Slide 1+2+3+4+5+6+7+8

Q54.Do the exercises on slide 2

Slide 9+10+11

Q55.20MVA Star/ Star connected transformer. 33KV/ 11KV

No load test

Line voltage = 11KV

Line current = 20A

Power = 80KW

Short circuit test

Line voltage= 1800V L-L

Line current = rated current

Power=100KW

Draw the equivalent circuit of transformer . All components referred to primary.

Slide 12

Q56.Sketch auto transformer & write the advantage of using it.

(9) Harmonic in transformer + All day efficiency

Slide 13+14+15

Q57.Explain harmonics in transformer.

Slide 16+19

Q58.Explain the effect of transformer connection on harmonic

Slide 17

Q59.Write the ways to reduce / eliminate harmonic in power transformer

Slide 18+19+20+21+22+23+24+25

Q60. Write the effect of transformer harmonic

Q61. Do the exercises on slide 20+21+22+23+24+25

Slide 26+27+28+29+30

Q62. Do the exercises on slide 26+27+28+29+30

Slide 31+32+33

Q63. Find all day efficiency of the following transformer 300 KVA, single phase, Iron loss=600W Full load copper loss = 800W 24 hr load cycle.

Time	Power factor	Output
10 hr	0.9 Lag	200KW
3hr	0.7 lag	150 KVA
3hr	40KVA & 30 KW	
3hr	Energized with no load	
The rest of time	De-energized	

-----  
 (10) Unbalanced load+ Parallel+ Cooling +Tap changing+ Efficiency

Slide 1+2+3

Q64. Describe briefly the various stages of on-load tap changers used in power system.

Q65. List two fundamental features of no load tap changing circuits.

Slide 4

Q66. Briefly describe the effect of tap changing on the limitation of power system operation.

Slide 5+6+7

Q67. 2000KVA, 6600/415V three phase delta/ star transformer %R=2 %X=5 Maximum efficiency occurs at 1/3 load

Calculate (a) Iron loss (b) Full load efficiency at 0.9 PF lagging (c) Maximum efficiency at 0.7 PF lagging.

Slide 8

Q68. How does the unbalanced load on three phase transformer cause the magnetomotive force in it?

Slide 9

Q69. Describe the examples of unbalanced loading

Slide 11

Q70. What are the requirements for parallel operation of three phase transformers

Slide 12+13+14

Q71. Tr A =  $3+j6\%$  15MVA , Tr B =  $4+j8\%$  25MVA

Calculate

- (a) % Impedance of 25 MVA transformer to base 15MVA
- (b) MVA supplied by each transformer if load is 20 MVA at unity PF.

Slide 15+16

Q72. Do the exercises on slide 15+16

-----

(11) Rating + Conservator system

Slide 1+2+3

Q73. Sketch the following cooling arrangements : AN, AF, ONAF, OFAF, ONAN, OFWF

Slide 4

Q74. Briefly describe the methods used in measuring oil and winding temperatures.

Slide 5

Q75. Describe the construction and use of dry type transformer.

Q76. List two types of windings used in dry type

Q77. List the requirements for oil in oil immersed transformer

Q78. List the important characteristics for oil testing

Slide 6+7+8

Q79. Describe the tests to determine the characteristics of transformer.

Slide 9

Q80. Describe dissolved GAS analysis (DGA) of insulating oil.

Slide 10+11

Q81. Do the exercises for problems in slide 10.

Slide 12

Q82. What types of transformers can be parallel?

(12) Winding series & parallel + Phase shift

Slide 1

Q83. Why do the transformers connect in series and parallel?

Slide 2+3

Q84. Describe the equation that VA of auto transformer related to 2 windings transformer.

Slide 4

Q85. Sketch phase shift transformer

Slide 5+6

Q86. A phase shift transformer is designed to control 200MVA on 230KV three phase line. The phase angle is variable between zero & +/- 15 degree.

(a) Calculate the appropriate basic power rating of transformer

(b) Calculate the line currents in incoming & outgoing lines

Slide 7+8

Q87. Explain booster transformer

Q88. Explain phase shift transformer

Slide 9

Q89. Sketch voltage control in distribution network

Slide 10

Q90. Explain the construction & operation of constant current transformer

Slide 11+12+13+14+15

Q91. Do the exercises on slide 11+12+13+14+15

-----

(13) Polarity

Slide 1 to 17

Q92. Do the exercises on slide 1, 6, 7, 8, 11 and 13

G042

(1) Comparing power systems

Slide 1+2+3

Q1. Compare the copper weight of 3 phase 3 wires system &amp; simple dc system

Slide 4+5

Q2. Explain voltage variations in power system

Slide 6

Q3. Sketch induction motor &amp; synchronous motor

Slide 7

Q4. Explain the components of circuit breaker

(2) DC Transmission system

Slide 1+2+3

Q5. The following is the arrangement of 240V dc supply system.

Point	Per wire					
	O	A	B	C	D	E
Component	240V Generation	$R_{oa}=0.05\Omega$ 5 A	$R_{ab}=0.1\Omega$ 3 A	$R_{bc}=0.1\Omega$ 2 A	$R_{cd}=0.1\Omega$ 1 A	$R_{de}=0.15\Omega$ 2 A

Calculate  $V_a$ ,  $V_b$ ,  $V_c$ ,  $V_d$ ,  $V_e$  & line efficiency

Slide 4+5+6

Q6. DC compound generator has  $0.2\Omega$  armature resistance,  $0.05\Omega$  series winding resistance and  $100\Omega$  shunt winding resistance. It is supplying the following loads.

- (a) 5 HP 240V efficiency 85% DC motor
- (b) 10 x 60w lamp with 240V.
- (c) 3000W water heater

Calculate (a) Generated voltage of dc compound generator if it is connected in short shunt compound and HP of prime mover if generator efficiency is 95%

(b) Generated voltage of dc compound generator if it is connected in long shunt compound &amp; HP of prime mover if generator efficiency is 90%

Slide 7+8+9+10+11

Q7. Do the exercises on slide 7

---

(3) Reflection in transmission line

Slide 1+2+3+4+5

Q8. A  $60\Omega$  transmission line connected to load impedance  $100+j70\Omega$ . The forward RMS value on line is 30V. Line impedance is  $30\Omega$

Calculate (a) Power delivered to resistance part of load impedance

(b) RMS current in impedance, reflected wave voltage

(c) Peak voltage forward & backward wave

(d) Voltage standing wave ratio (VSWR)

(e) Return loss in decibel

Slide 6

Q9. Explain the impact of switching in power line

Slide 7+8+9+10

Q10. A coil of 20H inductance and  $10\Omega$  resistance is connected in parallel with a  $30\Omega$  resistor across a 150V dc supply which is suddenly disconnected.

Find

(a) Initial rate change of current after switching

(b) The voltage across  $30\Omega$  resistor initially after 0.4 sec

(c) The voltage across the switch contacts at the instance of separation

(d) The rate at which the coil is losing stored energy 0.3 sec after switching

Slide 11

Q11. Write the formula to calculate arc resistance .

Slide 12

Q12. Write the voltage surge across opening contacts.

---

(4) Power factor connection

Slide 1+2+3+4+5+6+7

Q13. What is power factor. What are the effects of poor power factor



Q14. Four three phase 415V 50HZ loads are connected together in an industrial installation.

Determine (a) Total load (b) Total power factor (c) The value of capacitor required PF to 0.98

Slide 8+9

Q15. A load with a PF 0.7 lagging dissipates 1500W from 240V, 50HZ supply. It is required to correct the PF to 0.95 lagging. Find (a) The original and final currents (b) The value of the component to be added in parallel with the original load to achieve the required PF correction.

-----

(5) Overhead transmission line

Slide 1+2

Q16. Sketch Tee and Pi equivalent circuits of transmission line and vector diagram.

Slide 3+4

Q17. Sketch two ports network equivalent circuit and write the equation.

Slide 5

Q18. By doing open circuit test and short circuit test for parallel line model, the following values are obtained.

OCT— $V_s = 12V$ ,  $V_r = 12.5V$   $I_s = 0.1$  amp

SCT--- $V_s = 13V$ ,  $I_r = 0.4A$   $I_s = 0.48$  amp

Find the generalized equation

Slide 6

Q19. Sketch power transformer protection circuit.

Slide 7

Q20. Sketch recloser

Slide 8+9

Q21.

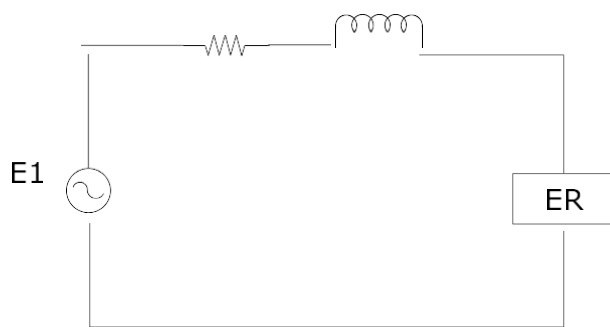

Single phase equivalent circuit (Short line)

In above circuit, the load consumes 2000Watt at PF 0.85 and voltage 415V. The transmission line impedance is  $Z = 3 + j4 \Omega$ , calculate sending end voltage for (a) 0.7 PF lagging (b) 0.85 PF leading

Slide 10+11+12+14

Q22. Write the voltage and current equations for Pi and Tee line circuits.

Slide 15+16+17

Q23. A three phase 66KV line is supplying 500 KW at 0.85 PF lagging. Line resistance, inductive reactance and capacitive reactance are  $1\Omega$ ,  $4\Omega$  and  $3000\Omega$  respectively. Calculate the sending end voltage by using equivalent Pi circuit.

Slide 18+19

Q24. What factors are to be considered for power system planning.

Slide 20+21

Q25. A sum of \$2000 is invested at 5% for 15 years at compound interest.

- (a) Calculate the sum at the end of 15 years
- (b) If instead of lump sum at the end of 15 years, the loan of \$2000 is to be paid by the fixed amount around each year, calculate the annual amount.

-----

(6) Waveforms in telecom line

Slide 1

Q26. Sketch standing wave & second wave

Slide 2

Q27. Write the equation for reflection coefficient and voltage standing wave ratio

Slide 3

Q28. Explain the transmission system

Slide 4+5+6

Q29. A  $60\Omega$  transmission line is connected to a load impedance  $50 + j70\Omega$ . The forward wave voltage RMS value on line is 30V. Calculate

- (a) Power delivered to resistive part of load impedance
- (b) RMS current in impedance reflected wave voltage RMS size
- (c) Peak voltage, forward and backward waves
- (d) Voltage standing wave ratio (VSWR)
- (e) Return loss in decibel

Slide 7+8+9=10

Q30.Explain the effect of reflection & impedance matching.

Slide 11+12

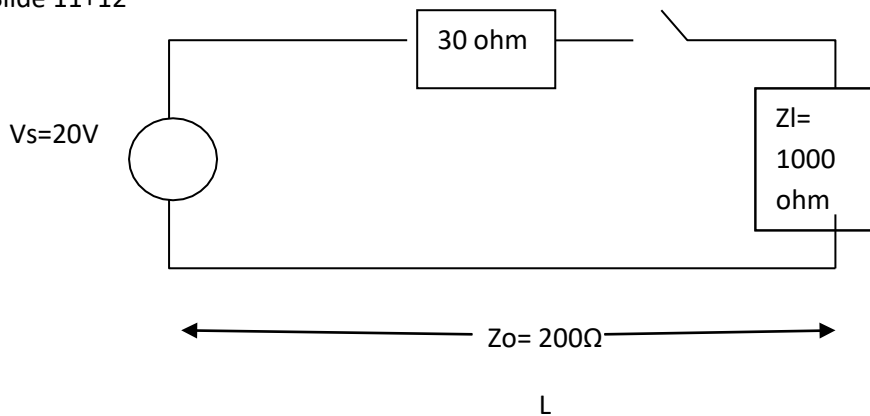

A 20V dc source with internal resistance 30 ohm is connected to a transmission line of length (L) having an impedance of 200 ohm by the switch. The transmission line is terminated with 1000 ohm resistor. T = amount of time required for a signal to travel the length of transmission line. Calculate

- Total voltage of the first reflection at load
- Total voltage of the second reflection at source
- Total voltage of the third reflection at load

(7) Line impedance matching

Slide 1

Q32.Explain transmission line matching with sketch.

Slide 2

Q33.Explain matching stud.

Slide 3

Q34.Write (a) Resonant frequency equation (b) Capacitance of concentric cable (c) Capacitance of 2 wires line

Q35.Write voltage reflection equation.

Slide 4+5

Q36.Explain wave propagation , direction of propagation (Wave guide)

Slide 6

Q37.Explain rectangular metal pipe wave guide with sketch.

Slide 7+8+9+10+11

Q38.Explain

- (a) Circular wave guide
- (b) TE
- (c) TM
- (d) TEM
- (e) Hybrid
- (f) Slotted waveguide

-----

(8) Smith chart

Slide 1+2+3+4+5+6

Q39.Find the input impedance and VSWR of a transmission line  $4.5\lambda$  long when  $Z_0=150\Omega$  &  $Z_L=200-j180\Omega$

Slide 7+8+9

Q40.A load of  $8+j55\Omega$  is to be matched to a  $60\Omega$  transmission line using a  $\lambda / 5$  matching section. Determine the proper location and characteristics impedance of the matching section.

-----

(9) Transmission line overview

Slide 1+2+3

Q41.What is transmission line . Explain the components of it.

Slide 4\_6

Q42.Explain maximum transfer of electrical energy.

Slide 5+7+8

Q43.Explain surge impedance loading.

Slide 9

Q44.Describe long and short transmission lines.

Slide 10+11+12+13

Q45.Explain (a)Propagation constant (b) Line model & SIL

Slide 14+15

Q46.Write the equations to calculate complex power.

Slide 16

Q47. What are the differences between a balanced line & an unbalanced line.

---

(10) Smith chart part 2 + wave guide

Slide 1+2+3+4+5+6+7+8+9

Q48.

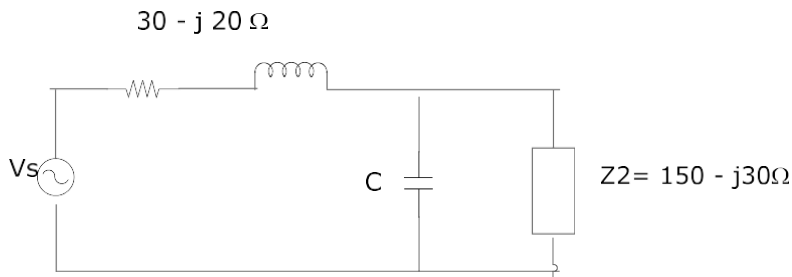

Find the matching impedance and capacitance for the given transmission line by using a Smith chart.

Slide 10

Q49. Explain the following with sketches

- (a) Waveguide (b) Diplexer (c) Phase shifter (d) Phase splitter (e) Circulator

Slide 11+12+13

Q50. Explain micro-strip transmission line with necessary sketches.

---

(11) Power transmission line + Per unit value

Slide 1+2+3

Q51.

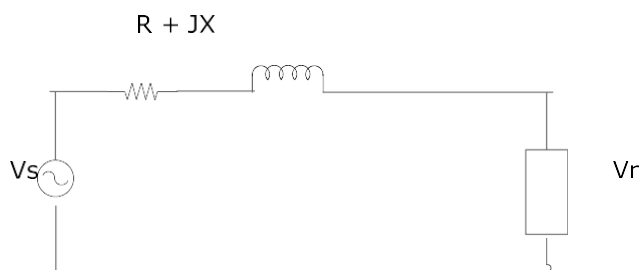

In the above circuit, the load consumes 2000 W at PF 0.8 & voltage of 415 V. Line impedance Z is  $2 + j3$  Ω. Find (a)  $V_s$  for lagging PF (b) Leading PF.

Q52.

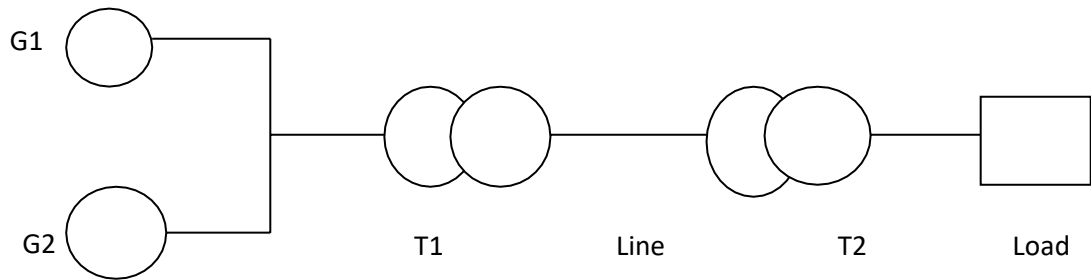

G1-2000VA 250V  $Z = j0.3$  pu

G2-4000VA 250V  $Z = j0.3$  pu

T1=5000VA 250/800V  $z = j0.2$  pu

Line  $Z=70+j30$  ohm

T2= 8000VA 800/400 V  $Z=j0.09$  pu

Load---3000VA 400V

Calculate PU impedance referred to base 5000VA 250V

Q53.

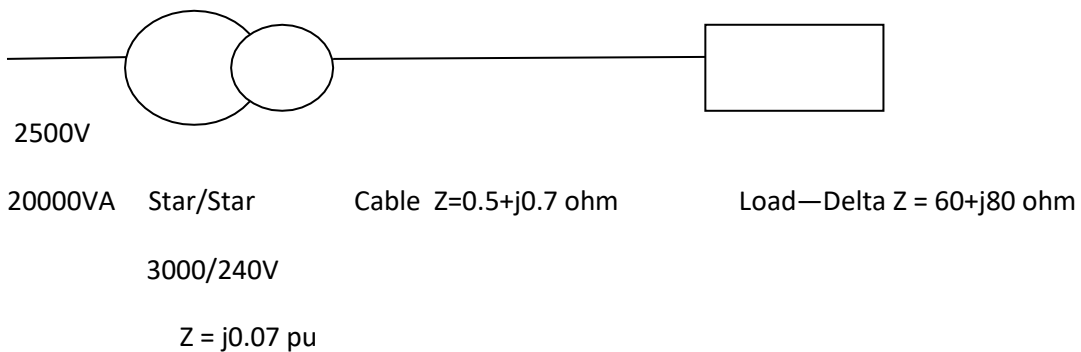

Take base voltage 2500V, 30,000 VA . Find equivalent diagram.

Slide 9+10+11+12

Q54.Determine the constant Pi model single phase line having the following specifications.

Outside diameter = 0.7 in spacing = 15 ft Geometric radius = 0.02 ft

Resistance / mile = 0.18 ohm

Line length= 50 miles.

Slide 13+14

Q55.

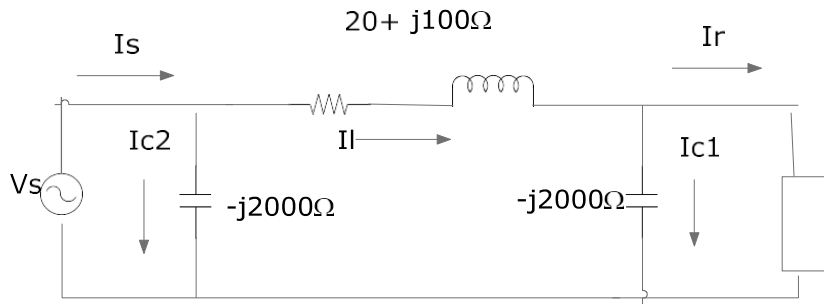

Single phase load on given is 15000KW unity pf supplied at 150 KV. Calculate  $I_s$ ,  $V_s$ , power supplied by generator.

Slide 15+16

Q56.

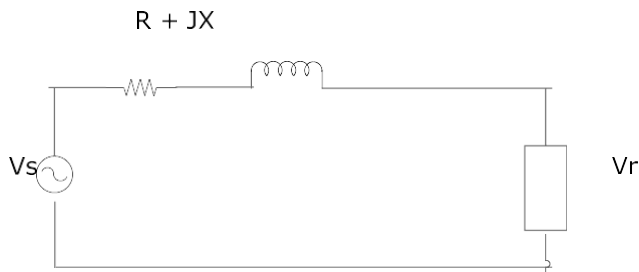

In above circuit, the load consumes 5000w at pf 0.9 lagging . The sending end voltage is 700V and the impedance  $Z = 2 + j3$  ohm. Determine load voltage.

Slide 17+18

Q57. Determine the constants in pi model single phase line having the following specifications. Outside diameter= 0.65 in, spacing 10 ft, resistance per mile = 0.25 ohm. Line length = 100 miles.

Slide 21+22

Q58.

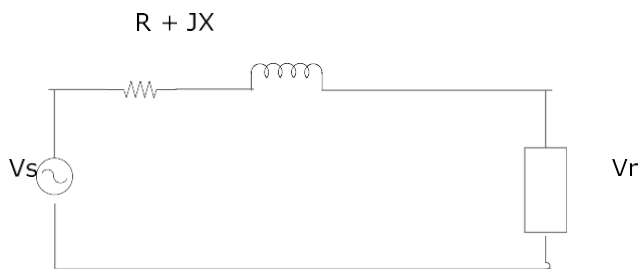

In above circuit, the load consumes 6000w at PF 0.85 lagging. The sending end voltage is 1KV. The line impedance is  $Z = 3 + j4$  ohm. Determine load voltage.

G043+G045

G045—Induction machines

(1) AC Machine introduction

Slide 1+2+3

Q1. Derive the formula to calculate rotating magnetic field.

Slide 4+5

Q2. Calculate the synchronous speed of a three phase induction motor having 12 poles, 60Hz.

Slide 6

Q3. Explain the starting characteristics of squirrel cage motor.

Slide 7.

Q4. Sketch the construction of squirrel cage induction motor and wound rotor motor.

Slide 8+9+10+11+12

Q5. Design three phase 48 slots 4 poles winding.

---

(2) Induction motor

Slide 1

Q6. What is distribution factor?

Slide 2

Q7. What is coil span factor?

Slide 3

Q8. How do distribution factor & coil span factor affect the induced emf?

Slide 4+5

Q9. A 0.7 HP 4 poles induction motor is excited by a single phase 50Hz source. At full load speed is 1160 rpm. Calculate the slip.

Slide 6+7

Q10. The 4 pole wound rotor induction motor is excited by a three phase 50Hz. Calculate the frequency of the rotor current under the following conditions.

- (a) At stand still
- (b) Motor turning at 600 rpm in the same direction as the revolving field.
- (c) Motor turning at 600 rpm in the opposite direction to the revolving field.



(d) Motor turning at 1800 rpm in the same direction to the revolving field.

Slide 8+9+10

Q11.(a) Calculate the approximate full load current . locked rotor current and no load current of a three phase induction motor having a rating of 600HP, 2400V.

(b) Estimate the apparent power drawn under locked rotor conduction.

(c) State the normal rating of this motor expressed in kilowatt.

-----

(3) Motor equivalent circuit.

Slide 1+2

Q12.Sketch the equivalent circuit & equation of induction motor.

-----

(4) Wound rotor motor

Slide 1

Q13.Sketch DOL starter

Q14.Write equations for locked rotor current & locked rotor torque.

Slide 2+3+4

Q20.Write the equation for motor current at stand still condition & any slip.

Q21.A 440V 6 poles three phase 50 HZ induction motor has its winding delta connected & its rotor winding star connected. The standstill voltage measured between slip ring with the rotor open circuit 220V. The stator resistance / phase is 0.7 ohm and the stator reactance / phase is 5 ohm. The rotor resistance per phase is 0.07 ohm and rotor reactance per phase is 0.3 ohm. Calculate the rotor current and stator current when slip rings are short circuited to start the motor. Calculate rotor power factor & stator power factor.

Slide 5

Q22.In above problem , calculate rotor current and stator current when slip rings are connected to 5 ohm external resistance and motor is running at 0.04 slip.

Slide 6

Q23.Sketch power transfer in induction machine for (a) motor mode (b) generator mode.

Slide 7+8

Q24.Write the following equations.

(a) Power absorbed by ideal stator winding

(b) Power dissipated in rotor circuit.

- (c) Mechanical power
- (d) Power dissipated in rotor resistance
- (e) Rotor circuit power loss
- (f) Power absorbed by ideal stator winding.

Slide 9

Q25. A 400 V 4 poles three phase 60HZ slip ring induction motor has its stator winding delta connected and rotor winding star connected. The standstill voltage measured between slip rings with the rotor open circuited is 220V. The stator resistance per phase is 4 ohm. The rotor resistance per phase is 0.08 ohm and the rotor reactance per phase is 0.35 ohm. Calculate the maximum torque & slip.

-----

(5) Torque + Motor test

Slide 1

Q26. Sketch the power flow diagram in motor.

Q27. Write the equation for

- (a) Mechanical power developed by rotor
- (b) Mechanical power delivered to load.
- (c) Mechanical torque.

-----

(6) Synchronous speed + Slip + Power of motor

Slide 1

Q28. A three phase induction motor having synchronous speed of 1200 rpm draws 90kw from three phase feeder. Copper loss & iron loss in stator amount to 7kw. If the motor runs at 1140 rpm, calculate the followings.

- (a) Active power transmitted to the rotor
- (b) Rotor  $I^2 R$  loss.
- (c) Mechanical power developed.
- (d) The mechanical power delivered to the load knowing that the windage & friction losses are equal to 1.5 kw.
- (e) The efficiency of motor.

Slide 2+3

Q29. A three phase 8 poles squirrel cage induction motor connected to 50Hz line possesses a rotor speed 1000 rpm. The motor absorbs 45kw and the copper & iron losses in the stator to 6 kw & 2 kw respectively. Calculate the torque developed by motor.

Slide 3+4

Q30. A three phase induction motor having a nominal rating of 80 kw and synchronous speed of 1800 rpm is connected to 660V source. Two meters method show a total power consumption 80kw and an ammeter indicates a line current 77 amp. Rotor speed is 1750 rpm. The following ratings are obtained. Stator iron loss = 2.5 kw, windage and friction loss = 1.5 kw. Resistance between two stators = 0.3 ohm.

Calculate (a) Power supplied to the rotor.

(b) Rotor  $I^2 R$  loss

(c) Mechanical power supplied to the load

(d) Efficiency

(e) Torque developed at 1750 rpm.

-----

(7) Motor starters

Slide 1+2

Q31. Describe the motor reduced voltage starting methods.

Slide 3+4+5+6

Q32. Sketch DOL starter.

-----

(8) Three phase motor equivalent circuit

Slide 1+2+3

Q33. Explain the tests to determine the equivalent circuit of three phase motor.

Slide 4+5

Q34. A no load test conducted on a 50HP 900 rpm 415 V three phase 50HZ squirrel cage induction motor yield the following results

No load test

No load voltage (L- L) = 415V

No load current = 15 A

No load power = 1450 watt

Resistance measured between two terminals

Locked rotor test

The locked rotor test conducted at reduced voltage gave the following results

Locked voltage (L to L) = 170V

Locked rotor power = 7500w

Locked rotor current = 70A

Determine the equivalent circuit of motor.

Slide 6+7+8+9

Q35.

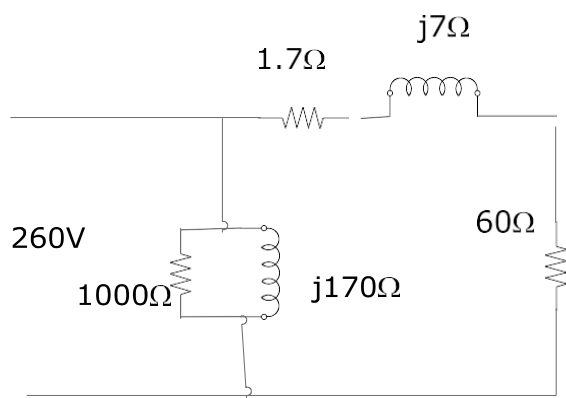

Calculate

- Active power delivered to rotor
- Mechanical power input to shaft
- Stator power input.
- Input current & PF
- If windage & friction loss is 80w

Find the output torque & efficiency speed = 1900 rpm.

Slide 10

Q36.

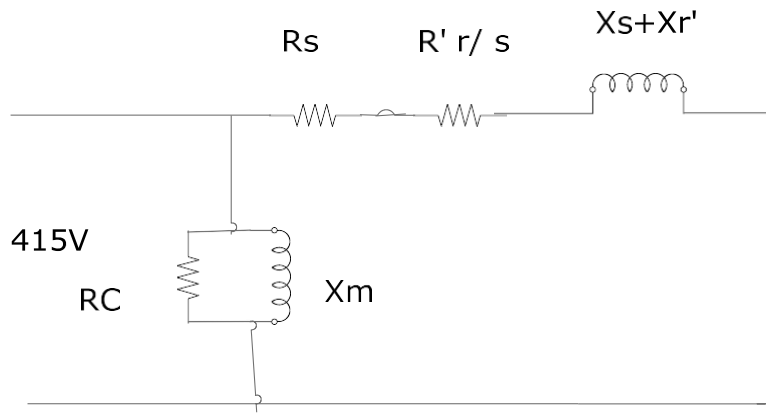

In the appropriate equivalent circuit of one phase of a three phase delta connected induction motor shown in above figure.

$V_s = 415\text{V}$   $R_c = 300\text{ ohm}$   $R_s = 0.2\text{ ohm}$  ,  $R'_r = 0.2\text{ ohm}$   $X_m = 30\text{ ohm}$   $X_s + X_{r'} = 2\text{ ohm}$ .

Determine the input current , power factor , input power and efficiency if the full load slip is 0.04 .  
When the machine is connected to a three phase 415V 50HZ supply.

Slide 11+12+13+14+15

Q37. An 8 pole 50HZ three phase slip ring induction motor has a total leakage impedance  $(3+j7\text{ ohm})$  per phase referred to the stator . The stator resistance per phase is 1.5 ohm. When 415V is applied to delta connected to stator winding, the voltage between any pair of open circuited slipring

To which the star connected rotor winding is connected to 240v.

- When slip rings are short circuited , the slip is 0.05 , calculate torque
- When slip rings are connected to external resistor 0.6 ohm / phase, slip is 0.07.

Calculate torque.

Slide 16+17+18

Q38. A single phase 240V 6 poles 50Hz 0.6 kw induction motor gave the following test results.

Locked rotor test= 100 v 2A, PF 0.7 lagging

No load test = 240V 0.7A PF 0.18 lagging

Determine the appropriate equivalent circuit, torque, power output, input current, power factor, slip at 0.06.

Slide 19+20+21+22

Q39. Three phase 210V induction motor has synchronous speed 1200 rpm run at 1110 rpm connected to 220V at constant load torque. Calculate the speed if connected to 230V.

Slide 22

Q40. A three phase 8 poles induction motor driving a compressor runs at 860 rpm immediately after it is connected to a fixed 500V 60 HZ line. The initial cold rotor temperature is 25 °C, the speed drops to 850 rpm after the machine has run for several hours.

Calculate (a) Hot rotor resistance in term of cold resistance

(b) The appropriate hot temperature of rotor bars knowing they are made of copper.

Slide 23+24+25+26

Q41. A three phase 4 pole wound rotor induction motor has a rating of 150 kw, 1770 rpm, 3 KV, 60HZ, three external resistances of 3 ohm are connected in star across the rotor slip rings under these conditions.

The motor develops a torque of 360 N-m at a speed of 1200 rpm.

(a) Calculate the speed for a torque of 450N-m

(b) Calculate the value of external resistance so that the motor develops 15 kw at 800 rpm.

Slide 27+28

Q42. A three phase wound rotor induction motor has a rating of 120 kw, 1750 rpm 3 KV 60 HZ.

Under locked rotor condition, the open circuit rotor voltage between the slip ring is 600V. The rotor is driven by a variable speed dc motor.

Calculate

(a) The turn ratio of the stator to rotor winding

(b) The rotor voltage & frequency when the rotor is driven at 730 rpm in the same direction as the revolving field.

(c) The rotor voltage and frequency when the rotor is driven at 750 rpm opposite to the revolving field.

Slide 29+30

Q43. We wish to use a 35 kw 900 rpm 50HZ wound rotor motor as a frequency converter to generate 70 kw at an approximate frequency of 170 HZ. If the supply line frequency is 50HZ, calculate the followings

(a) The speed of the induction motor that drives the frequency converter.

(b) The active power delivered to the stator of the frequency converter

(c) The power of the induction motor

(d) Will the frequency converter overheat under these conditions

Slide 31

Q44. Sketch slip torque characteristics of induction motor.

Slide 32

Q45.Explain stability & crawling

---

(9) Reduced voltage starting methods

Slide 1

Q46.Why does reduced starting voltage needed to start the induction motor and write the types of reduced voltage starters.

Slide 2+3

Q47.Explain the followings with sketches.

- (a) Star delta starter
- (b) Auto transformer starter
- (c) Slip ring motor

Slide 4

Q48.Sketch the speed & torque diagram & indicate the crawling point.

Slide 5+6+7

Q49.A three phase squirrel cage induction motor has a stator resistance per phase  $0.7\Omega$  and a rotor resistance per phase referred to stator of  $0.7\Omega$ . Total standstill reactance per phase referred to stator is  $5.72\Omega$ . If the ratio of the maximum torque to full load torque is 3:1. Find the ratio of actual starting torque to full load torque for (a) Direct starting (b) Star / delta starting (c) Auto transformer starting with 78% tapping.

---

(10) Reduced voltage starting

Slide 1+2

Q50.Explain automatic voltage starter with sketch.

Slide 3+4

Q51.Explain Star / delta starter with sketch.

Slide 5+6+7+8+9+10

Q52. Explain consequent pole starter.

Slide 11

Q53.Explain consequent pole starter.

Slide 12+13

Q54.Explain silicon controlled SCR & it's application in motor speed control with sketches.

Slide 14+15

Q55.Explain wound rotor motor.

Slide 16

Q56.Explain (a) Multi switch starter (b) Drum controller

Slide 17

Q57.Explain application of slip ring motor

Q58.What are advantages and disadvantages of using squirrel cage induction motor?

Slide 18+19

Q60.Explain frequency & speed control methods.

Slide 19

Q61.Explain (a) Multi speed starter (b) Motor protection

Slide 20 to 27

Q62.Explain the followings with sketch.

- (a) Jogging
- (b) Plugging
- (c) Braking

Slide 28

Q63.Explain mechanical braking

---

G043-Synchronous machines

(11) Synchronous machines

Slide 1+2+3

Q64.Explain the major difference between induction machine and synchronous machine.

Slide 3+4+5+6

Q65.Explain the construction of synchronous machine

---

(12) Synchronous generator

Slide 1

Q66.Sketch the equivalent circuit , vector diagram and write the voltage equation for synchronous generator.

Slide 2



Q67. Sketch the circuit, vector diagram and write the voltage equation for synchronous motor.

-----

(13) Effect of field excitation

Slide 1+2

Q68. Explain the effect of field excitation on power factor of synchronous motor.

Slide 3+4+5

Q69. A three phase star connected alternator has a resistance of  $0.3\Omega$  and a synchronous reactance of  $7\Omega$  per phase. It is excited to give 6.6KV line voltage on open circuit. Determine the internal voltage and per unit voltage regulation on full load current of 150 amp when the load power factor is (a) 0.707 lagging (b) 0.8 leading.

Slide 6+7

Q70. A 4000 Kw 6.6 KV 50 HZ 250 rpm synchronous motor operates at full load 0.7 leading power factor if the synchronous reactance is  $15\Omega$ . Calculate the followings

- (a) The apparent power of the motor per phase
- (b) The AC line current
- (c) The value and phase of  $E_f$
- (d) Determine the torque angle  $\delta$

Slide 8+9+10

Q71. A synchronous condenser is rated at 260MVAR 26 KV 1500 rpm, 60HZ. It has a synchronous reactance of 0.8 pu and is connected to 26KV line. Calculate the value of  $E_f$  so that the machine (a) absorb 200MVAR (b) deliver 150 MVAR

-----

(14) Oscillation of synchronous machines

Slide 1+2

Q72. A 3000KV three phase 4 poles star connected synchronous machine has resistance and synchronous reactance per phase of  $0.3\Omega$  and  $2\Omega$  respectively. Calculate the emf and rotor displacement when the machine acts as a motor with input of 700MW and pf 0.9 lagging.

If the field current is required to produce emf / ph equal to rated voltage. Determine also field current for field excitation.

Slide 3+4+5+6

Q73. The factory has the following loads.

- (a) 3 x 50HP three phase induction motor PF 0.6 lagging , efficiency 85%
- (b) 4 x 45 Kw three phase induction motor 0.85 pf lagging, efficiency 90%

Calculate total active and reactive power. If one 100KW three phase synchronous motor with 97% efficiency, 0.65 leading pf is connected in parallel, calculate total active and reactive power and power factor.

Slide 6+7+8

Q74.Explain starting methods for synchronous motor.

Slide 9+10

Q75.Compare synchronous motor & induction motor

Slide 11+12 (Single phase motor)

Q76.Explain (a) cross field theory (b) rotating field theory of single phase motor.

---

(15) Generator control

Slide 1+2

Q77.Explain the control of electric generating system.

Slide 3+4

Q78.Explain voltage regulator.

Slide 5+6+7

Q79.Explain prime mover & governor

Slide 8+9

Q80.Explain the types of excitations

Slide 10+11

Q81.How will you select the regulator to control generator voltage?

Slide 12+13

Q82.What are the factors affecting voltage stability of generator system?

Slide 14+15

Q83. Sketch remote voltage sensing system

Slide 16

Q84.Explain typical generator instability problem.

Slide 17+18+22+23

Q85.Explain digital excitation system.

Slide 19+20+21

Q86. Sketch generator parallel control system.

Slide 24

Q87. Explain digital voltage regulation system.

---

(16) Single phase motor

Slide 1+2+3+4

Q88. Explain the features of single phase motor.

Slide 5

Q89. Sketch capacitor start motor & explain.

Slide 6+7+8+9

Q90. Sketch

- (a) Capacitor start / capacitor run motor
- (b) Permanently split capacitor motor
- (c) Shaded pole motor
- (d) Universal motor

Slide 10

Q91. Compare single phase and three phase motor.

Slide 11

What are the abnormal operation of three phase motor?

Slide 12

Q92. Describe motor maintenance methods.

Slide 13

Q93. Sketch equivalent circuit of single phase motor.

Slide 14

Q94. A small 50HZ hysteresis clock motor possesses 32 poles. In making one turn, hysteresis loss in motor is 0.9J.

Find

- (a) Pull in / pull out torque.

- (b) Maximum power output before motor stalls.
- (c) Rotor losses when the motor stalls.
- (d) Rotor losses when the motor runs at synchronous speed.

(`17) Synchronous impedance

Slide 1+2

Q95.How will you determine synchronous impedance?

Slide 3+4+5

Q96.A three phase star connected alternator has a resistance  $0.6\Omega$  and synchronous reactance  $10\Omega$  / phase. It is excited to give 6000V. line on open circuit.

Calculate (a) Synchronous impedance (b) Short circuit current when open circuit voltage is 600V at terminal .

Slide 6

Q97.Explain excitation and reactive power.

Slide 7

Q98.Explain excitation methods.

Slide 8

Q99.Explain the connection of synchronous motor with sketch.

Q100.Explain cylindrical rotor machine.

Slide 9+10

Q101.A 600HP 720 rpm synchronous motor connected to 4000V three phase line generates an excitation voltage  $E_f=1800V$  (L-N) when the dc excitation current is 35 amp. The synchronous reactance is  $25\Omega$ , torque angle between  $E_f$  &  $V$  is  $35^\circ$ . Calculate (a) The value of impedance drop  $E_z$  (b) AC line current (c) PF of motor (d) HP of motor (e)Shaft torque.

Slide 11+12

Q101.A 20KW 1200 rpm 415V three phase synchronous motor has synchronous reactance  $0.9\Omega$ / ph. If  $E_f$  is fixed at 400v/ ph . Determine the followings (a) Mechanical power/ phase (b) torque (c) $\delta$ .

Slide 13+14

Q102.A three phase 600KV , 5 KW 180 rpm 60HZ motor has synchronous reactance  $1.5\Omega$  at full load . The motor poles are displaced by mechanical angle of 2 degree from their no load position. If the line to neutral excitation  $E_f = 2.5KV$ . Calculate the mechanical torque developed.

Slide 15

Q103.Explain synchronous motor VEE curve characteristics.

Slide 16+17

Q104.Explain the effect of varying field excitation.

-----

(18) Single phase motor problems.

Slide 1 to 8

Q105.A test on 1/5 HP 110V 50HZ 1750 rpm single phase motor has the following parameters.

Stator resistance =  $1\Omega$ , rotor resistance referred to stator  $2\Omega$ . Stator leakage reactance =  $4\Omega$ ,

Rotor leakage reactance referred to stator =  $3.6\Omega$ , windage and friction + iron loss resistance =  $700\Omega$ ,  
Magnetizing reactance =  $50\Omega$ ,

Draw the equivalent circuit & determine the output efficiency & power factor of motor when it runs at 1750 rpm.

Slide 9+10+11

Q106.A resistance split phase motor is rated at 1/5 HP, 1750 rpm , 110V, 50HZ. When the rotor is locked, a test at reduced voltage on machine and auxiliary winding.

	Main winding	Auxiliar winding
Applied voltage	E=30V	E=30V
Current	$I_s = 5$ amp	$I_a = 2.5$ amp
Active power	$P_s = 70$ W	$P_a = 25$ W

Calculate (a)The phase angle between  $I_a$  and  $I_s$ .

(b)Locked rotor current drawn from 110V line

Slide 12+13+14+15

Q107.Explain synchronous motor control.

Slide 16+17

Q108.Explain solid state control.

Slide 18+19+20+21+22

Q109.Explain excitation system working into field of synchronous motor.

-----

(19) Force on motor

Slide 1+2

Q110. An electric motor lifts a mass of 600Kg through a height of 40m in 18 sec. Calculate power developed by the motor in KW and HP.

Slide 3

Q111. During a prong brake test on electric motor, the spring scale 30N & 7N respectively. Calculate power output if the motor turns at 1800 rpm & the radius of pulley is 0.2m.

Slide 4+5

Q112. A flywheel having a shape given in figure composed of a ring supported by a rectangular hub. The ring & hub respectively have a mass of 90Kg and 10 Kg. Calculate the moment of inertia of flywheel.

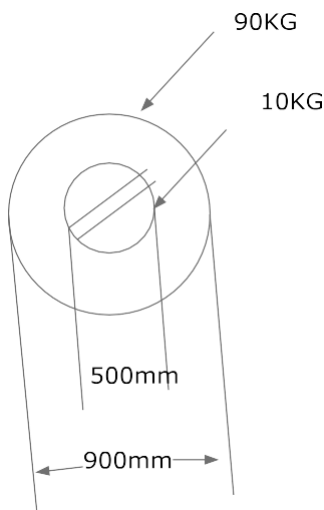

Slide 6

Q113. The flywheel having moment of inertia  $12 \text{ kg} \cdot \text{m}^2$  in previous problem turns at 70 rpm. By applying the torque 25 N-m, the speed is increased to 700 rpm. How must the torque be applied?

Slide 7

Q114. Do the exercises in slide 7

Slide 8+9+10

Q115. A totally enclosed motor has an external surface area  $1.5 \text{ m}^2$ . When it operates at full load, surface temperature is  $70^\circ\text{C}$  and ambient temperature  $20^\circ\text{C}$ . Calculate the heat loss by natural convection.

Q116. A fan rated at 4 KW blows  $300\text{m}^3 / \text{min}$  of air through 800Kw motor to carry away the heat. If the inlet temperature is  $23^\circ\text{C}$  and the outlet temperature is  $32^\circ\text{C}$ , estimate the losses in rotor.

Slide 11.

Q117. The motor in above question is coated with a non metallic enamel, calculate the heat loss by radiation knowing that all surrounding objects are at an ambient temperature of  $30^\circ\text{C}$ .  $K = 6 \times 10^{-3}$   
 $A = 1.8\text{m}^2$ .

Slide 12+13

Q118. An AC machine turning at 880 rpm carries the rotor winding whose total weight is 50Kg. The current density is  $6\text{A} / \text{mm}^2$  & operating temperature is  $190^\circ\text{C}$ . Total iron losses are 1200W.  
 $\rho = 22\text{n}\Omega\text{-cm}$ ,  $\beta = 9000$ . Calculate (a) copper losses (b) the mechanical drag (N-m) due to iron loss.

Slide 14+15

Q119. Explain the classes of insulation.

Slide 16+19

Q120. A 80KW motor class F operates at full load in an ambient temperature  $33^\circ\text{C}$  if the hot spot temperature is  $127^\circ\text{C}$ . Does the motor meet the temperature standard?

Slide 17+18+20+21

Q121. Do the exercises on slide 17

Slide 22

Q122. How does the speed and size of synchronous machine relate?

Slide 23+24+25

Q123. Do the exercises on slide 23.

G044

(1) DC Machine

Slide 1+2

Q1.Explain generator action & motor action

Slide 3

Q2.Sketch the construction of dc generator.

Slide 4

Q3.Write the generated voltage equation.

Slide 5+6

Q4.Label the parts of dc machine

Q5.Sketch the following connections of dc machine

(a) Shunt (b)Series (c)Separately excited (d) Compound

---

(2) Armature winding

Slide 1+2

Q6.Sketch lap winding and wave winding

Q7.Calculate the coil pitch  $Y_p$  and indicate the slot number in which the first coil is wound for each of the following cases assuming that the details are referred to a 4 poles machine.

(a)  $S=37$  (b)  $S=72$  (c)  $S=39$  (d)  $S=44$

Slide 3

Q8.Repeat the above example for the following cases assuming that in each , the data refers to a 6 poles machine (a)  $S=84$  (b)  $S=39$  (c)  $S=97$

Q9.Sketch (a) Progressive lap (b) Retrogressive lap

Slide 4

Q10.Find the commutator pitch of the following windings for 4 poles machine

(a) 37 slots simplex wave progressive

(b) 37 slots simplex wave retrogressive

(c) 36 slots duplex wave progressive

(d) 36 slots duplex wave retrogressive.

---



## (3) Torque production

Slide 1

Q11. Sketch mechanical action of dc generator &amp; motor

Slide 2+3+4

Q12. A motor has a combined moment of inertia of  $15 \text{ N-m /s}^2$  and initial velocity of  $260 \text{ rad/s}$ . If the torque produced by the motor is increased by  $60 \text{ N-m}$ , calculate (a) the time for the speed to reach  $400 \text{ rad/s}$

Slide 5+6+7

Q13. Sketch & write the equation for (a) shunt generator (b) Short shunt compound generator (c) Series motor (d) Shunt motor

Slide 8

Q14. Write the generated emf equation for generator and motor.

Slide 9+10+11

Q15. Explain the magnetic action of armature field distortion

Q16. An armature  $0.6 \text{ m}$  diameter of 6 poles lap wound generator has 450 conductors, carries  $350 \text{ amp}$  & has a pole arc  $0.19 \text{ m}$ . Calculate the cross magnetizing, armature reaction ampere-turn.

Slide 12

Q17. Explain the methods to reduce the armature reaction.

Slide 13

Q18. The brushes on a  $0.5 \text{ m}$  diameter commutator are rocked  $0.04 \text{ m}$  circumferentially. The machine has 6 poles, lap wound, 420 conductors,  $700 \text{ Armature current}$ . Calculate cross magnetizing and de-magnetizing ampere turn / pole.

-----  
(4) Armature reaction + commutation

Slide 14+15+16

Q19. The brushes on a  $0.8 \text{ m}$  diameter commutator are rocked  $0.04 \text{ m}$  circumferentially. The machine has 4 poles, lap wound, 360 conductors,  $800 \text{ Armature current}$ . Calculate cross magnetizing and de-magnetizing ampere turn / pole.

Slide 17

Q20. Explain the voltage of self induction.

Slide 19.

Q21. Sketch the power flow diagram in dc machine.

Slide 20+21+22+23

Q22. Describe the losses and efficiency in dc motor.

Slide 24+25+26

Q23. The winding resistance of a 600V 70KW dc shunt motor are  $R_a=0.3\Omega$ ,  $R_f=250\Omega$ . If the rotational losses can be taken as 1.5 KW, determine the efficiency of the machine (a) when the line current is 105 amp (b) at full load.

Slide 27+28

Q24. Sketch the power flow diagram of dc generator

Q25. Sketch the power flow diagram of dc motor.

-----  
(5) Voltage regulation + Efficiency

Slide 1+2+3

Q26. Explain maximum efficiency

Slide 3+4+5

Q27. A 80KW, 300V shunt generator has an armature circuit resistance of  $0.06\Omega$ , field resistance of  $100\Omega$  and maximum efficiency 92%. Calculate

(a) Total load for which the efficiency is approximately a maximum

(b) Stray power loss.

Slide 6

Q28. Explain machine temperature rise.

Slide 7

Q29. The resistance of an armature winding at  $30^\circ\text{C}$  was found to be  $0.29\Omega$ . After a heat run, it becomes  $0.306\Omega$ . Calculate the temperature rise of the winding.

Slide 8+9+10+11+12+13+14

Q30. Analyze the power losses in dc machine.

Slide 15

Q31. Calculate the eddy current and hysteresis losses for the given dc machine.  $K_e=3$   $K_h=2$ , frequency = 60HZ. Thickness of lamination 0.6mm, core flux density 15 tesla, volume of core =  $8\text{m}^3$  mass of core = 60Kg

Slide 16

Q32. Explain percentage voltage regulation.

Slide 17+18+19

Q33(a). Vfl of shunt generator is 500V, what is % regulation if the open circuit voltage 520V

Q33(b).A 100KW 1000V generator has a voltage regulation 3% , calculate

- (a) The open circuit voltage
- (b) Assuming the voltage varies uniformly between no load and full load current. Calculate the KW output of a terminal voltage 520V.

Slide 20+21

Q34.Sketch the generator loading circuit for shunt generator

Q35.Write the generated emf equation.

-----

(6) DC machine problem

Slide 1+2

Q36.Write transfer function of dc shunt generator and write the equation for generated voltage.

Slide 3+4

Q37.Write the transfer function and generated voltage equation of self excited machine.

Slide 5+6+7

Q38.A 60HP 240V 1200 rpm shunt dc motor has a rated armature current of 190 amp & rated field current 7 amp. When the rotor is blocked, the armature voltage is 15V, produces a 180A current flow and field voltage 240V produces a field current flow of 7A. At no load with terminal voltage equal to 230V, the armature current is equal to 14A, field current 5A, motor speed is 1170 rpm.

- (a) How much power is output from the motor at rated condition.
- (b) Motor efficiency.

Slide 8

Q39.A six poles wave wound dc generator has 420 active conductors. If the generator is driven at 800 rpm, calculate the open circuit voltage if useful flux per pole is 0.05wb.

-----

(7) Effect of flux on voltage

Slide 1+2+3+4

Q40.Motor particulars 4 KW, 240V, 15A, 1770 rpm  $R_a=0.5\Omega$  , brush drop 3V on load.

Calculate

- (a) Full load torque
- (b) Initial rush of armature current and corresponding torque at the instant field resistance is increasing to reduce the field flux to 0.9 of the original value
- (c) Find the armature current , speed and power consumption.

Slide 5+6+7+8+9+10

Q41. 7.5KW 240V 1770 rpm shunt motor, armature resistance  $0.4\Omega$ , shunt field resistance  $70\Omega$

- (a) No load current is 8 amp, full load efficiency 87% , brush drop 4V at full load. Calculate % regulation.
- (b) If  $3\Omega$  armature resistance is placed in series with armature circuit. Calculate the new speed, % regulation, % power loss in series resistance in respect of the total power input.

(8) DC motor control+ SCR

Slide 1+2+3

Q42. Sketch three phase speed control with SCR

Q43. Sketch the block diagram of SCR controlled motor.

Q44. What are the effects of ripples.

Slide 3

Q45. Sketch the torque-speed relationship curve and write the equation

Slide 4

Q46. A 4 poles wound armature operating in a field of flux  $0.03\text{wb}$  in wound with 400 armature conductors. Determine the expression of torque as a function of speed. If  $V_t=240\text{V}$  and  $R_a=0.15\Omega$ .

Slide 5

Q47. What is the duty cycle?

Slide 6

Q48. What is duty cycle?

Slide 6

Q48. Find RMS value of the given graph.

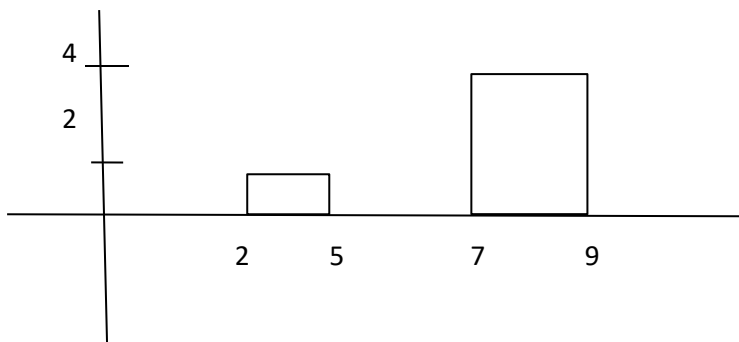

(9) DC motor starter

Slide 1

Q49. Sketch 4 points dc motor starter

Slide 2+3+4

Q50. The resistance of the armature of a 240V dc shunt motor is  $0.6\Omega$ . It is required that the current at starting be limited to 250% of full load current & full load current is 20A.

Determine

- (a) Total resistance of armature current at starting
- (b) The number of studs on the starter
- (c) Resistance between each stud.

Slide 5

Q51. Express the types of dc motor starters

Q52. Sketch armature current and time graph, speed and time graph.

Slide 6.

Q53. A 250V motor is required to be braked by plugging. If the armature current at full load is 200A and armature resistance is  $0.2\Omega$ , calculate the resistance of braking resistor if the initial braking current is limited to 200% of full load current and brush drop is 7V.

Slide 7

Q54. Sketch 4 points starter

Slide 8+9+10+11+12

Q55. A 150KW 500V dc shunt motor has an armature resistance  $0.3\Omega$  and full load speed 940rpm. If the load has a torque-speed curve which may be defined by the expression

$$T = 100 + 9.1 \times 10^{-4} N^2$$

And the motor armature particulars are

$Z = 760$  conductors,  $P = 4$  poles,  $a = 6$  parallel paths  $\phi = 0.07\text{wb}$

The combined inertia of load and armature is  $200\text{N-m}^2$ . Calculate (a) Stator resistance (b) Speed at each resistance steps (c) Torque

Slide 13

Q56. Sketch the power flow diagram of dc generator

Slide 14+15

Q57. The winding resistance of a 600V, 70KW dc shunt motor are  $R_a = 0.3\Omega$   $R_f = 300\Omega$ , mechanical losses are 2.4KW. Determine the efficiency of the machine.

- (a) When the line current is 98A (b) At full load

---

(10) DC motor starter circuit analysis

Slide 1+2+3+4+5+6

Q58. The armature of a 240V shunt motor has a resistance of  $0.9\Omega$  and takes 29A at full load.

(a) If  $I_a$  is not to exceed 170% of normal full load current at starting, calculate starting resistance.

(b) Determine  $I_a$  if no starting resistance is inserted. Assume brush drop 2V.

Slide 7

Q59. Explain dynamic braking with sketch.

Slide 8

Q60. The braking current of a 15KW 240V 60A motor is series wound. Total armature & field resistance  $0.3\Omega$  is to be limited to 1.8 times motor full load rating.

Calculate the value of the dynamic braking resistor. Assume  $E_g$  is 90% of rated voltage & brush drop is 4V.

Slide 9

Q61. Write the formula to calculate the acceleration time.

Slide 10

Q62. Describe the characteristics of the following dc motors.

(a) Series motor (b) Shunt motor (c) Compound motor

---

(11) DC motor speed control

Slide 1

Q63. Explain the principle of dc motor speed control

Slide 2

Q64. Sketch the block diagram of SCR controlled motor

Slide 3+4

Q65. Sketch the Ward Leonard system speed control and explain its operation.

Q66. Explain dc motor speed-torque characteristics.

Slide 5+6

Q67. A 4 pole wave wound armature operating in a field of flux 0.02 wb is wound with 300 armature conductors. Determine the expression of torque as a function of speed if  $V_t = 260V$  and  $R_a = 0.2\Omega$ .

Slide 7

Q68. Sketch dc motor torque and speed relationship graph for (a) shunt motor (b) series motor

Slide 8+9

Q69. For motor  $T = 3000 - 1.5 N$

For load (a)  $T = 70 + 1.8 N$

(b)  $T = 80 + 0.75 \times 10^{-4} N^2$

To match the motor and load, calculate the equilibrium speed in each instance.

Slide 10

Q70. Explain braking by plugging with sketch

Q71. Explain dynamic braking.

G047

(1) Linear and exponential function

Slide 1+2+3

Q1.

300V

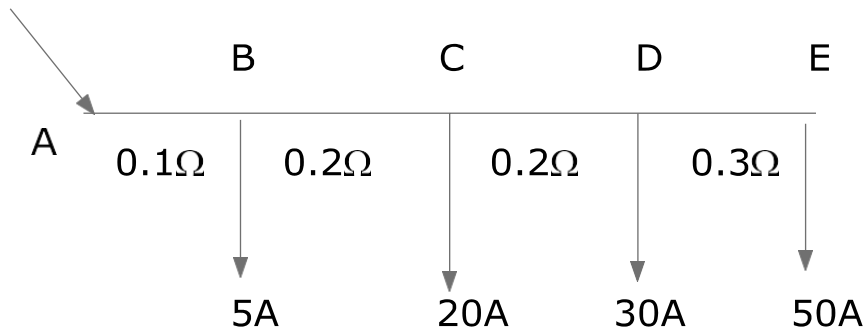

Find the load voltages at A,B,C,D,E for given power line &amp; line efficiency

Slide 4+5+6

Q2. Three towns A, B, C are located as follows. Determine the most suitable place to locate the electric power station to supply those towns.

A = 2000MW ( 10, 15) km

B= 500MW (8, 12) km

C= 600MW (10, 15) km

Slide 7+8+9

Q3. Write the polar form

(a)  $6 \angle 72^\circ$

(b)  $8 \angle -72^\circ$

(c)  $10 \angle -150^\circ$

(d)  $12 \angle 300^\circ$

(2) Ratio comparison

Slide 1+2+3

Q4. Compare dc power and AC three phase power loss.

(3) RLC circuit

Slide 1 to 9



Q5A. Find inductance reactance of  $L = 2\text{H}$ ,  $50\text{Hz}$ ,  $C = 2\ \mu\text{F}$   $60\text{Hz}$

Q5B. Convert the followings to polar form

(a)  $5 + j6\ \Omega$  (b)  $-4 + j3\ \Omega$  (c)  $4 - j3\ \Omega$  (d)  $-4 - j3\ \Omega$

Q5C. Convert the followings to rectangular form.

(a)  $10 \angle 53.2$  (b)  $10 \angle -53.2$  (c)  $10 \angle -150$  (d)  $10 \angle -240$

(4) Gradient, Log function

Slide 1+2+3

Q6.

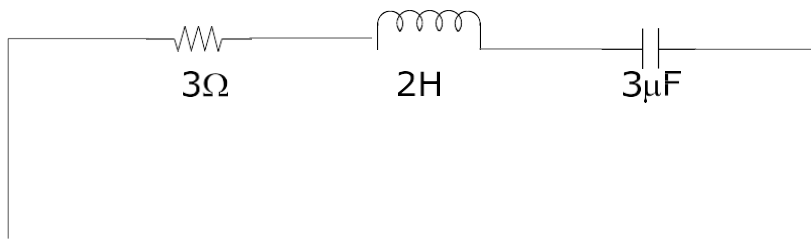

Find Z

Slide 4+5+6

Q7. Calculate

(a)  $(5 + j7) + (7 - j6)$

(b)  $(3 + j4) - (3 - j12)$

(c)  $(4 + j3) (2 + j1)$

(d)  $(3 + j4) (2 - j1)$

(e)  $4 + j3$

$$\frac{\quad}{3 + j4}$$

(f)  $3 + j4$

$$\frac{\quad}{3 - j4}$$

Slide 7+8

Q8. A transmission line has 300 m span between supports. The conductor weight is  $15\ \text{N/m}$  and tension in conductor is  $13\ \text{kN}$ . Calculate sag.

Slide 9+10+11

Q9. Three phase 33 KV transmission line is delivering 3 MW load at PF 0.96 lagging. Line conductors have 15 sq mm. The distance between them are 2m, 3m and 4m. The line is 400 km long. Line resistance is  $0.07 \Omega/\text{km}$ . Calculate total line inductive reactance and capacitive reactance at 60HZ.

-----

(5) Gradient application deviation

Slide 1+2+3+4

Q10. A single core concentric cable is to be manufactured for 300KV, 60HZ line. The paper used has maximum permissible safe stress of  $2 \times 10^7 \text{ V/m}$  (rms) and a di-electric constant of 6. Calculate dimension for the most economic cable & charging current per Km.

Slide 5+6+7+8

Q11. Derive the equation for potential grading of 3 insulators string.

-----

(6) Oscillation function

Slide 1+2+3+4

Q12. A 15V dc source with an internal resistance of  $30\Omega$  is connected to a transmission line of length "L" having an impedance of  $200\Omega$  by switch. The transmission line is terminated with a  $1000\Omega$  resistor. T = amount of time required for signal to travel the length of the line.

Calculate

- (a) The voltage when the switch is closed at  $T=0$
- (b) First reflection at load
- (c) Second reflection at source
- (d) Third reflection at load.

Slide 5+6+7

Q13. A coil of 15H inductance &  $10\Omega$  resistance is connected in parallel with a  $25\Omega$  resistor across a 200V dc supply which is suddenly disconnected .

Find

- (a) The rate of change of current after switching
- (b) Voltage across  $25\Omega$  resistor initially after 0.4 sec
- (c) The voltage across the switch contacts at the instance of separation
- (d) The rate at which the coil is losing stored energy 0.4 sec after switching.

Slide 8+9+10

Q14.

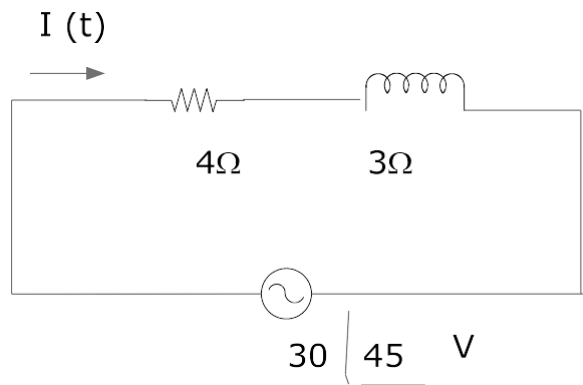

Find the current in (a) frequency domain representation (b) time domain representation  $f=50\text{Hz}$

-----

(7) Simultaneous equation

Slide 1+2+3+4

Q15. Determine A, B, C, D contents of the given network

$$A = 10, \quad A_2 = 10, \quad B_1 = 20 \left| \begin{array}{l} 30 \Omega \\ \end{array} \right. \quad B_2 = 0 \quad C_1 = 0 \text{ mho} \quad C_2 = 0.02 \left| \begin{array}{l} 50 \text{ mho} \\ \end{array} \right. \quad D_1 = 2 \quad D_2 = 2$$

Slide 5+6+7

Q16. Determine the A, B, C, D constants of the network in which the following test results have been observed.

Receiver open circuit

$$V_s = 120 \angle 0^\circ \text{ V}$$

$$V_r = 80 \left| \begin{array}{l} -45 \text{ V} \\ \end{array} \right.$$

$$I_s = 2 \left| \begin{array}{l} -30 \text{ A} \\ \end{array} \right.$$

$$I_r = 0$$

Receiver short circuit

$$V_r = 0$$

$$V_s = 120 \left| \begin{array}{l} 0 \text{ V} \\ \end{array} \right.$$

$$I_s = 3 \left| \begin{array}{l} -90 \text{ A} \\ \end{array} \right.$$

$$I_r = 3 \left| \begin{array}{l} -90 \text{ A} \\ \end{array} \right.$$

-----

(8) Waveforms

Q17. A wave form of  $T = 50\text{ms}$  calculate the frequency of fundamental, second, third & fourth harmonics

Slide 4

Q18. Calculate frequencies of the following waveforms

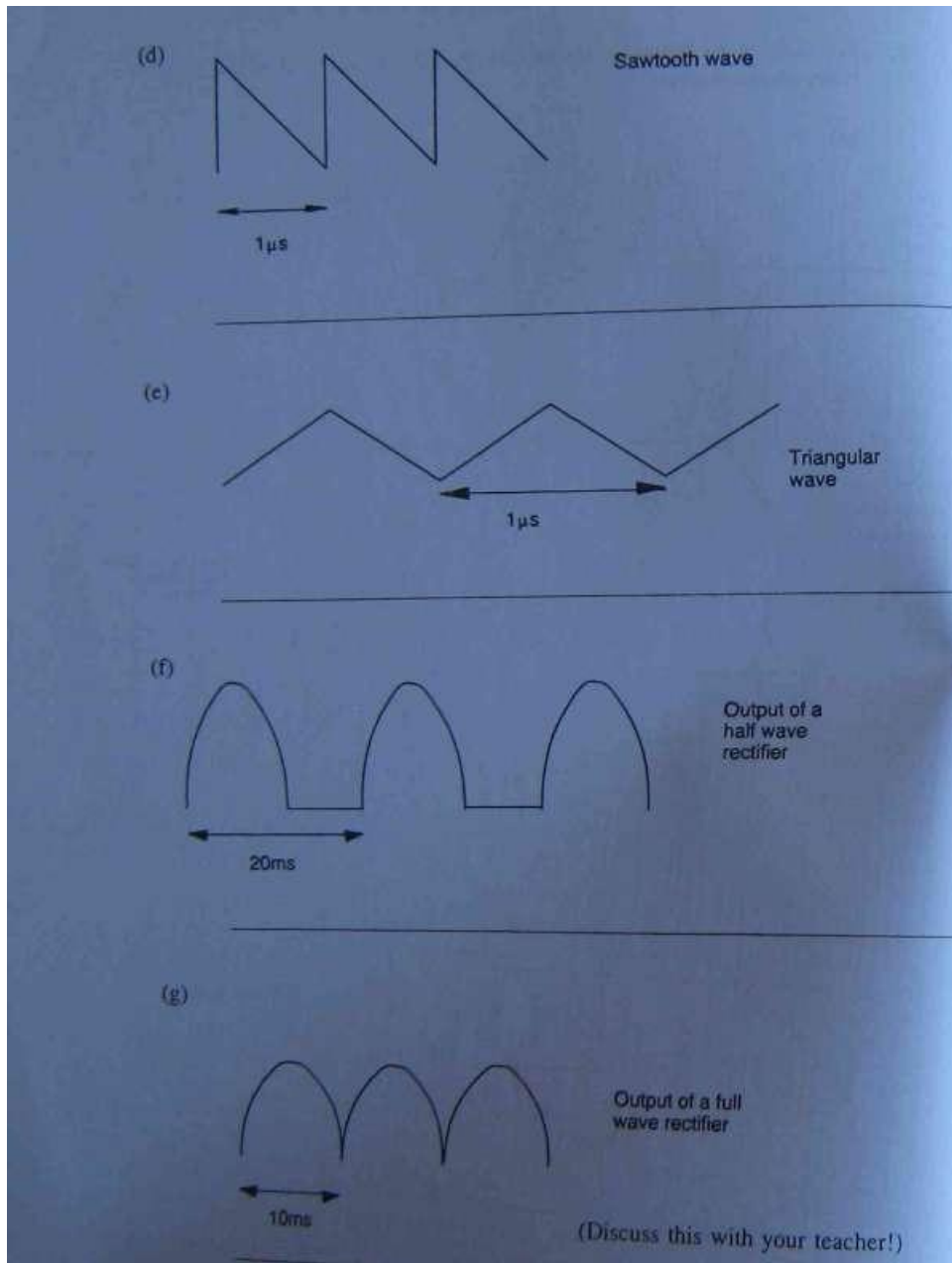

Slide 5+6+7+8+9+10

Q19. A voltage is given by  $e = 40 \sin \omega t + 50 \sin (3\omega t + 45) + 15 \sin (5\omega t - 80)$  volt is applied to a circuit & the resulting current is given by

$$I = 0.7 \sin (\omega t - 20) + 0.15 \sin (3\omega t - 25) + 0.09 \sin (5\omega t - 120)$$

Find total power applied and overall power factor.



G048

(1) Current source &amp; voltage source

Slide 1+2

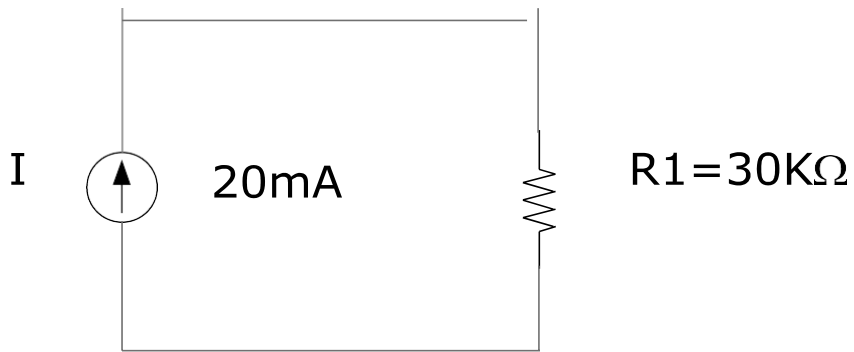
Q1. Find the source voltage  $V_s$  and current  $I_1$  for the given circuit.

Slide 3

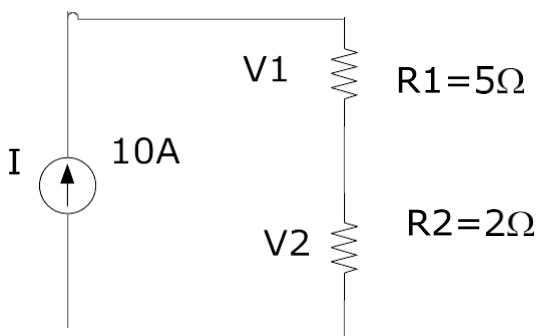
Q2. Calculate the voltage  $V_1$ ,  $V_2$  and  $V_s$  for the given circuit.

Slide 4

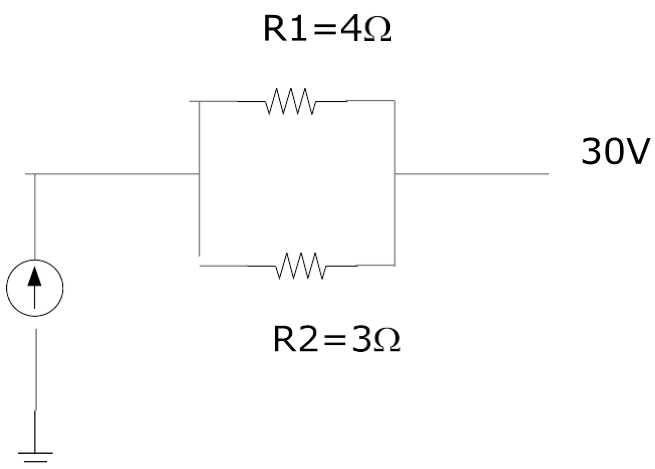
Q3. Determine the current  $I_1$  and the voltage  $V_s$  for the given network

Slide 5

Q4. Convert the voltage source of the given figure to a current source and calculate the current through 10Ω load

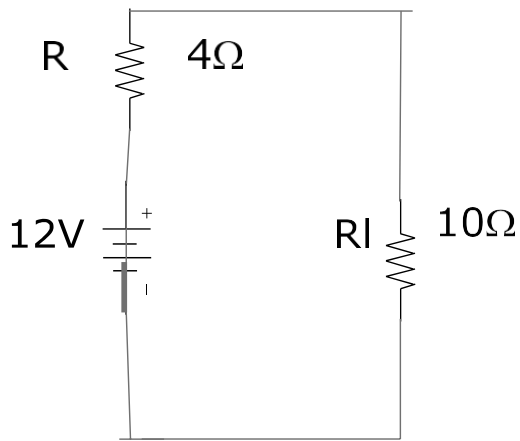

Slide6

Q5. Convert the given current source to a voltage source and find the load current .

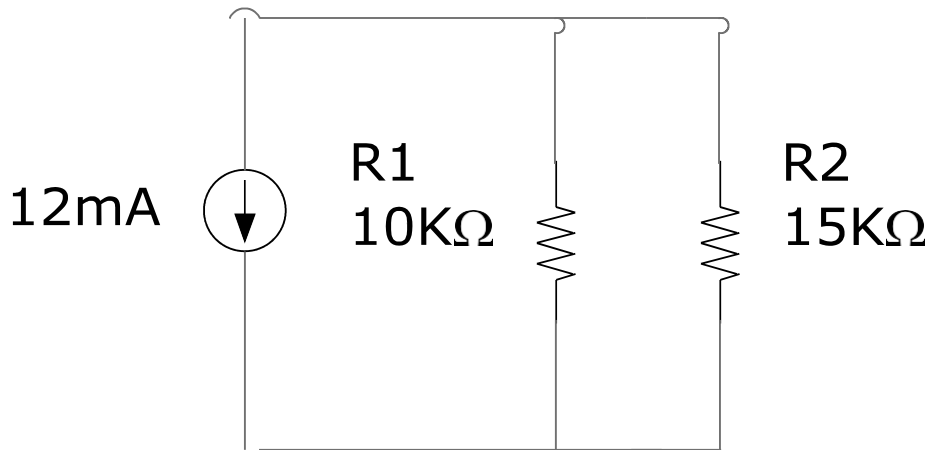

Slide 7+8+9

Q6. Reduce the parallel current source of given figure to a single current source.

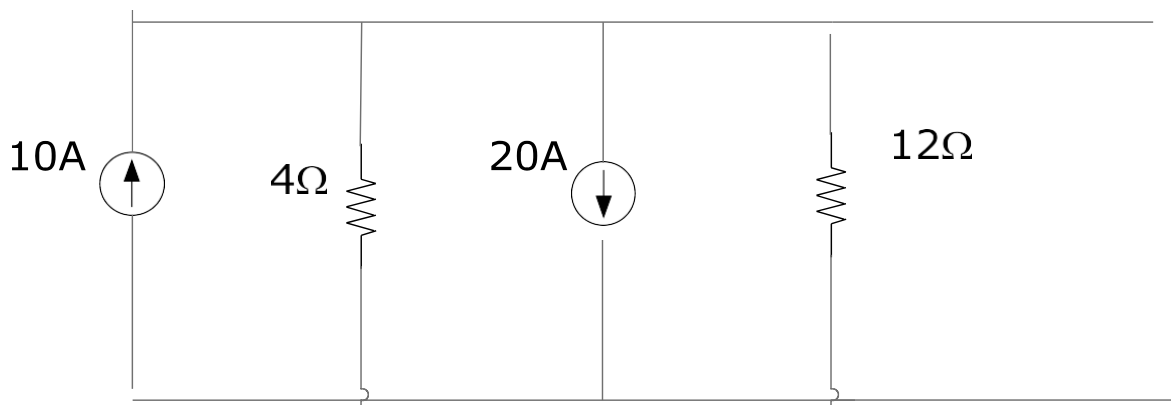

Slide 10+11+12+13+14+15+16

Q7.

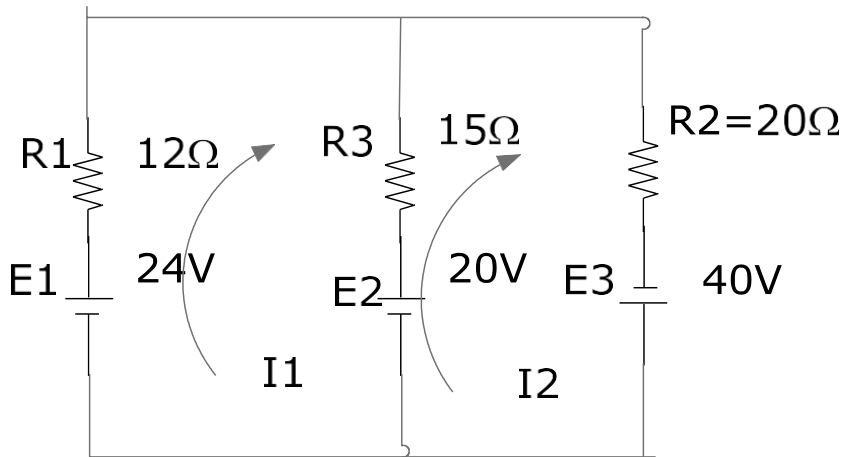

Find  $I_1$  &  $I_2$

Slide 17+18+19

Q8. Find the current through  $10\Omega$  resistor of the network.

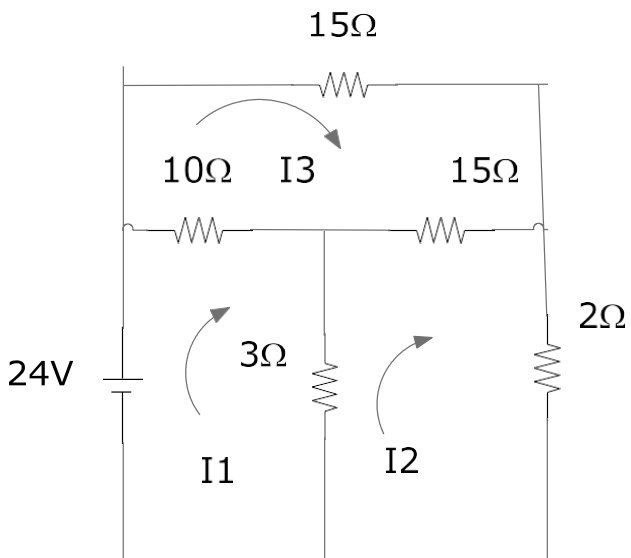

Slide 20

Q9. Convert delta of given circuit to star.

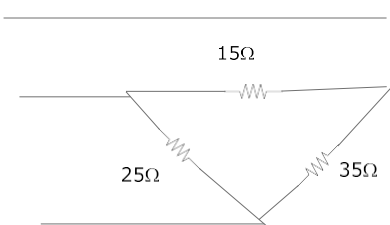

(2) Circuit solution

Slide 1+2

Q10.



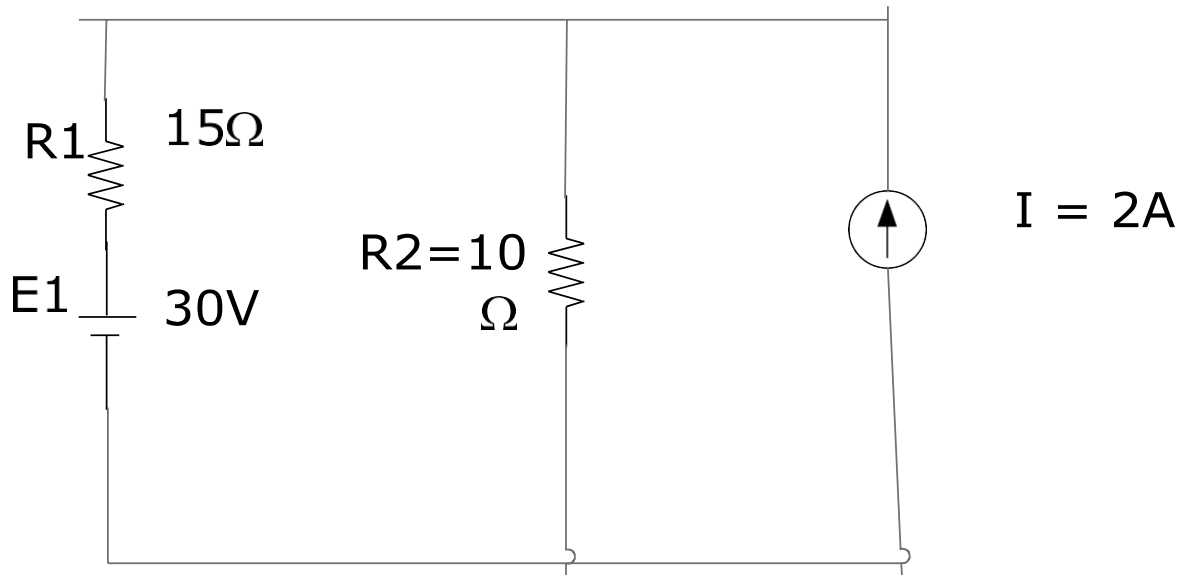

Calculate the current flows into R2 & delivered by 30V battery by using Nodal analysis

Slide 3+4+5

Q11. Determine the Nodal voltage for the given network.

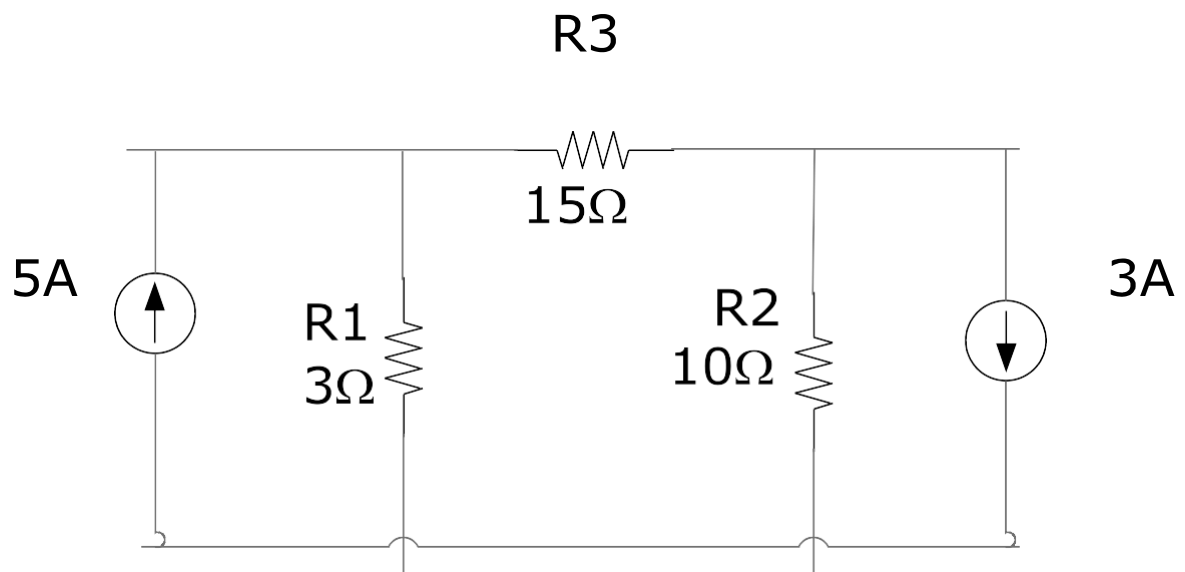

Slide 6+7+8

Q12. Find total resistance of the given network.

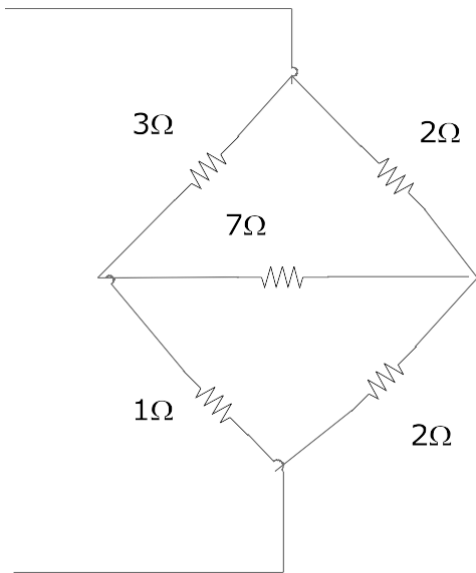

Slide 9

Q13. Convert the star of given circuit to delta

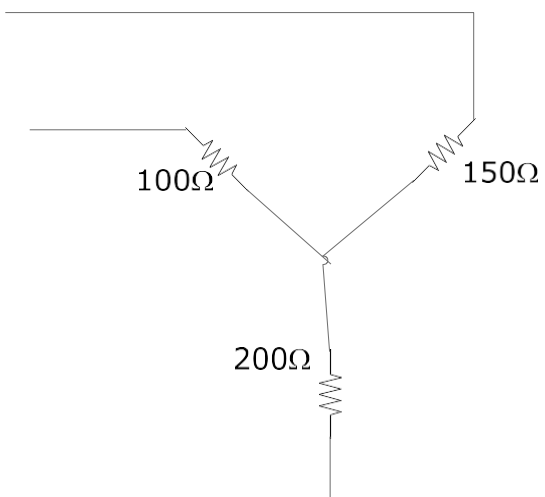

Q14. Convert delta of given circuit to star.

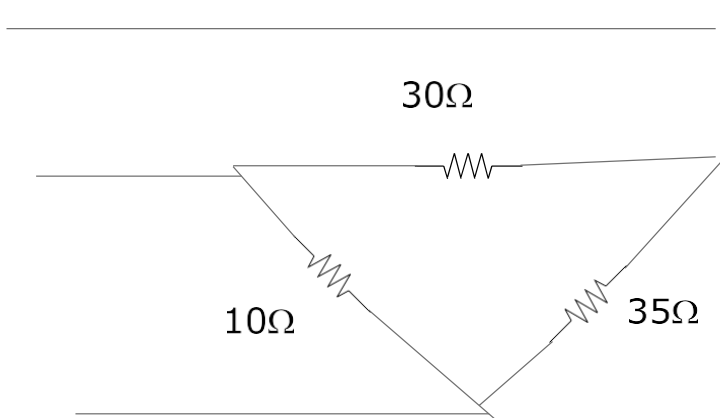

Slide 10

Q15. Find Norton's equivalent resistance terminal.

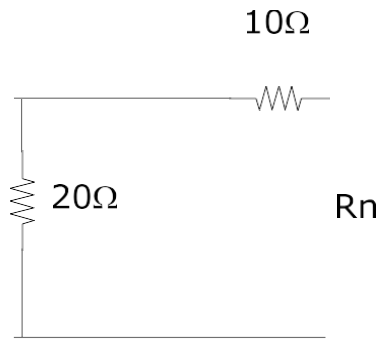

### (3) Nodal Analysis

Slide 1+2

Q16.

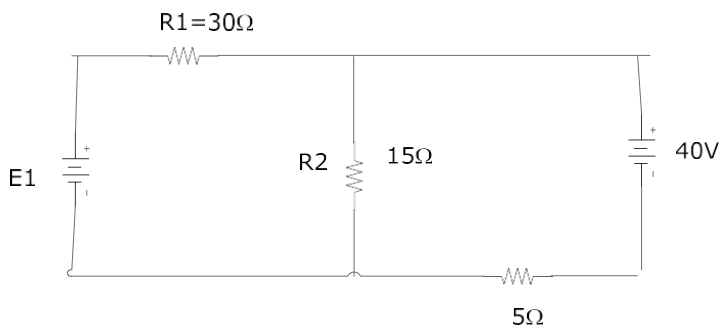

$E_1=60V$

Find the current in  $5\Omega$  resistor by superposition theorem.

Slide 3+4+5+6

Q17.

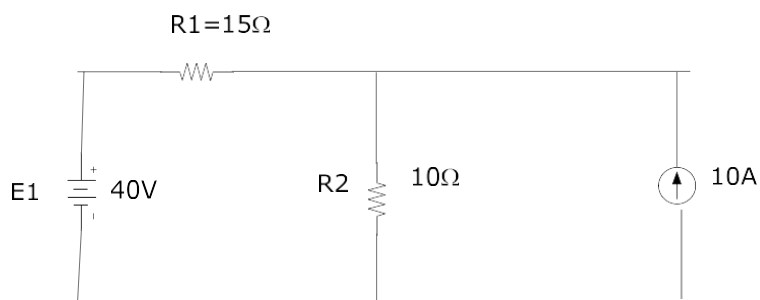

Using superposition theorem, find the current through  $R_2=10\Omega$ .

Slide 7

Q18.

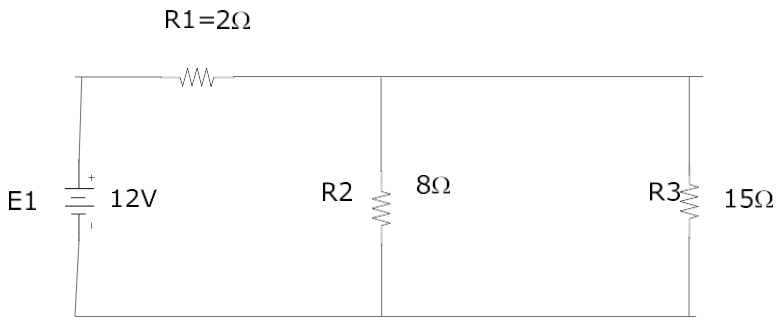

Find the current through  $15\Omega$  resistor by using Thevenin's theorem

Slide 8+9+10

Q19.

Find Thevenin's equivalent & current flow into  $R_3$

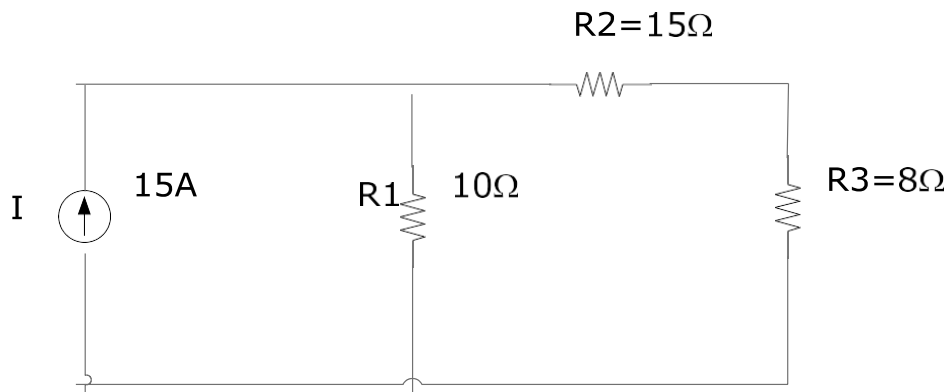

Slide 11

Q20. Find the current through  $10\Omega$  resistor by using Thevenin's theorem.

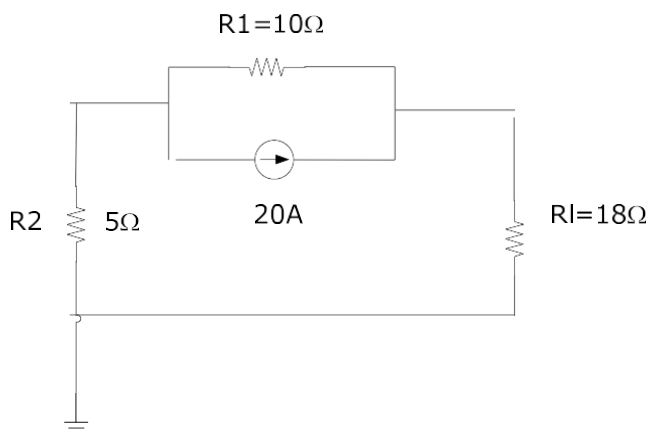

(4) Maximum power transfer theorem

Slide 1+2

Q21. A DC generator, battery and laboratory supply are connected to a resistive load  $R_l$  in figure a, b, c respectively.

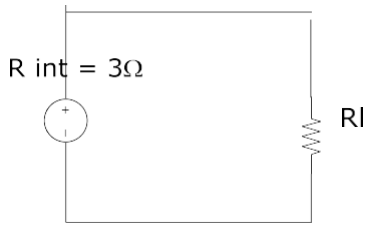

(a) DC Generator

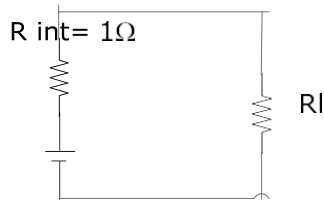

(b) Battery



Find (a)  $R_L$  for maximum power transfer (b)  $R_L$  for 75% efficiency.

Slide 3+4

Q22. For the network of given figure, determine the value of  $R$  for maximum power to  $R$  and calculate the power delivered under these conditions.

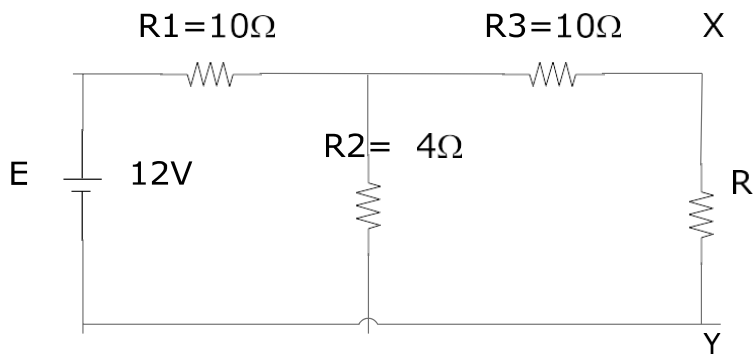

Slide 5+6+7

Q23. Find the value of  $R_L$  in figure for maximum power to  $R_L$  and determine the maximum power.

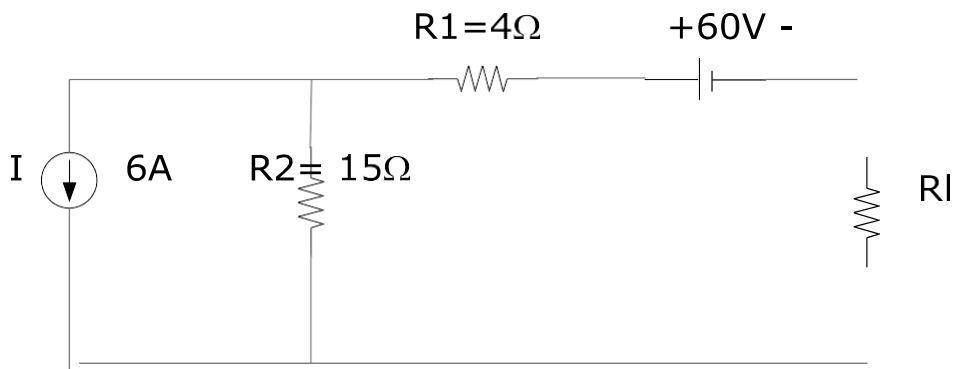

Slide 8+9

Q24. Using Millman's theorem, find the current through & voltage across  $R_L$

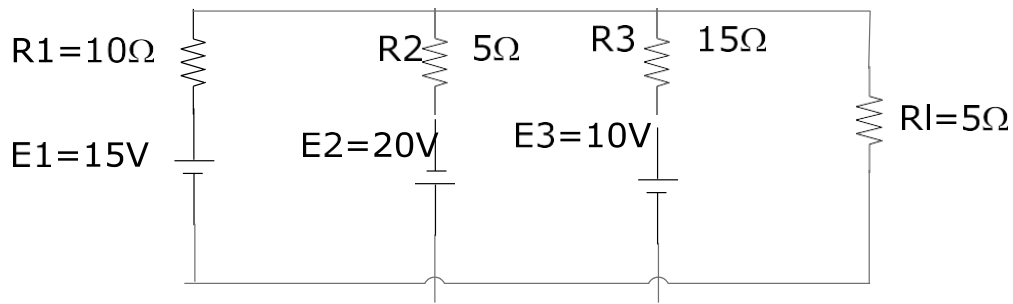

(5) AC Network theorem

Slide1+2+3+4+5

Q25.  $10 \sqrt{53.2} - 5 \sqrt{36.8}$

Q26.  $(4 + j3) (3 + j5)$

Q27. Using superposition theorem, find the current I through 5Ω reactance.

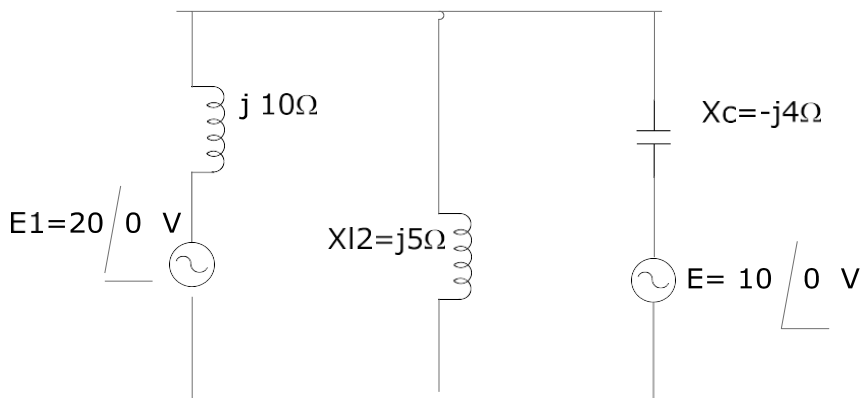

Slide 12+13+14

Q29. Using Superposition theorem, find the current I through 10Ω resistor

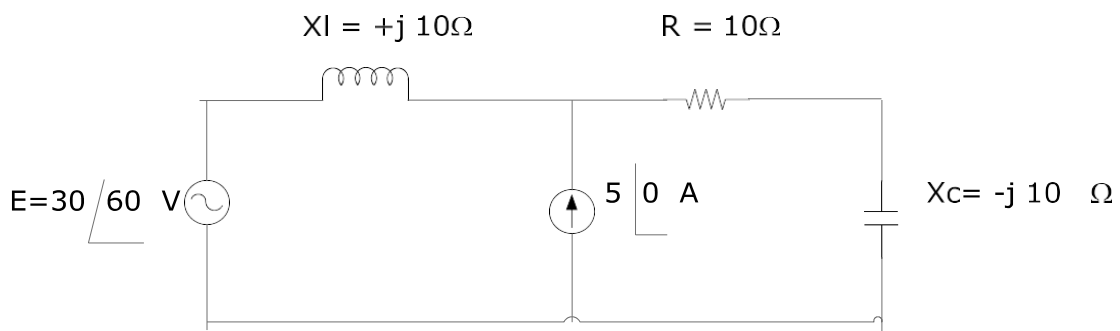

Slide 15+16+17+18+19

Q30. Find the Thevenin's equivalent circuit for the network external to " R ".

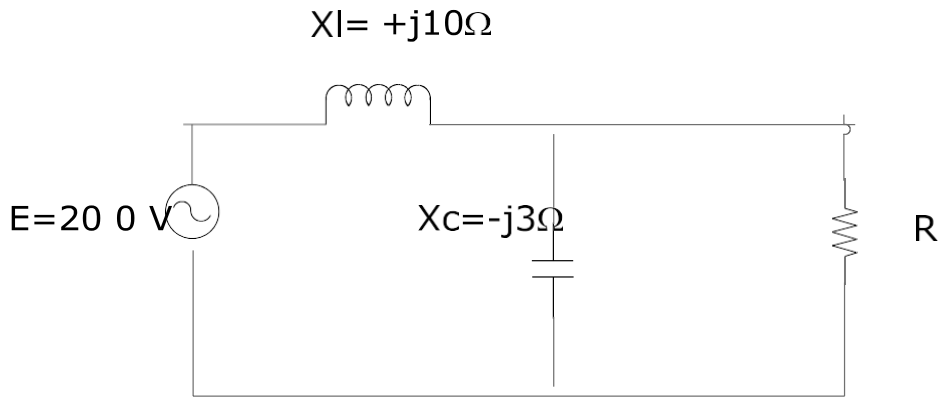

(6) Transient

Slide 1+2

Q31. Find the mathematical expression for the transient behaviour of  $V_c$ ,  $I_c$  and  $V_r$  for the given circuit when the switch is moved to position 1, plot the curves of  $V_c$ ,  $I_c$  and  $V_r$

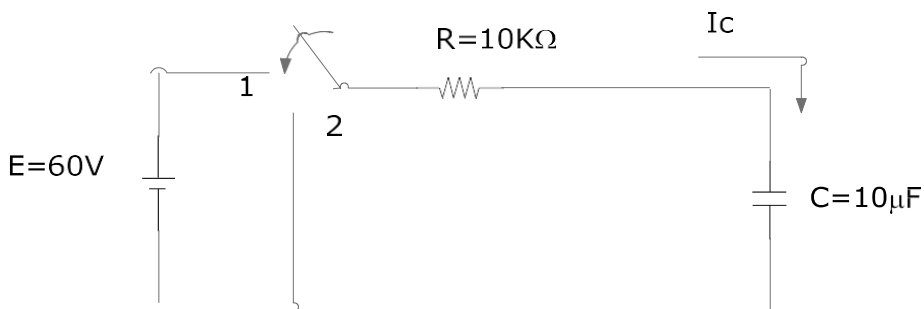

Slide 3+4+5

Q32.

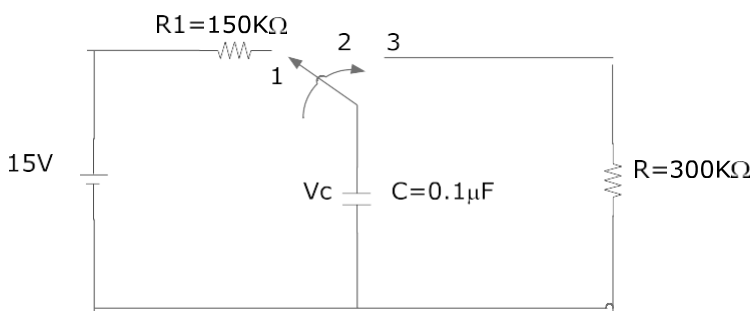

(a) Find the mathematical expression for the transient behaviour of the voltage across the capacitor

If the switch is thrown into position (1) at  $t=0$

(b) Repeat part (a) for  $I_c$

(c) Find the mathematical expressions for response of  $V_c$  &  $I_c$  if the switch is thrown into position 2 at 40ms

(d) Find the mathematical expression for the voltage  $V_c$  and current  $I_c$  if the switch is thrown into position 3 at  $t = 60ms$

(e) Plot the waveforms obtained in part (a) through part (d)

Slide 6+7+8

Q33. For the network given in figure

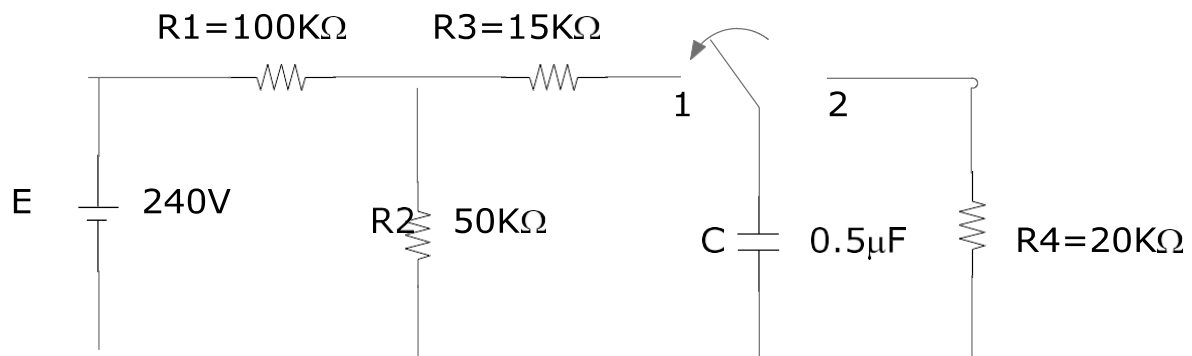

- Find the mathematical expression of the voltage  $V_c$  and the current  $I_c$  following the closing of the switch position 1 at  $t = 0$  sec
- Find the mathematical expression for the voltage  $V_c$  and current  $I_c$  as a function of time if the switch is thrown into the position 2 at  $t = 10$ ms
- Draw the resultant waveforms

Slide 11+12+13

Q34.

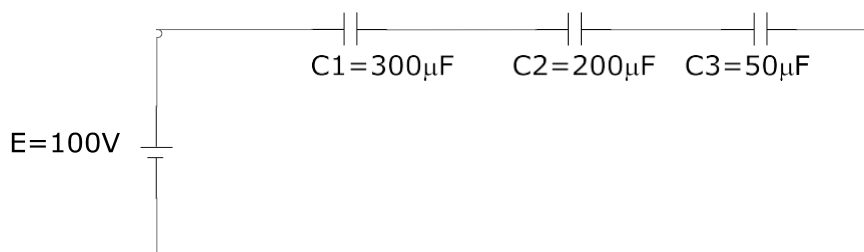

Find (a) Total capacitance (b) Determine the charge on each plate (c) Find the voltage across each capacitor.



G049

(1) Delta-Reverse sequence

Q1. Line voltage is 450V. Phase sequence is ABC. Find phase current and line currents.

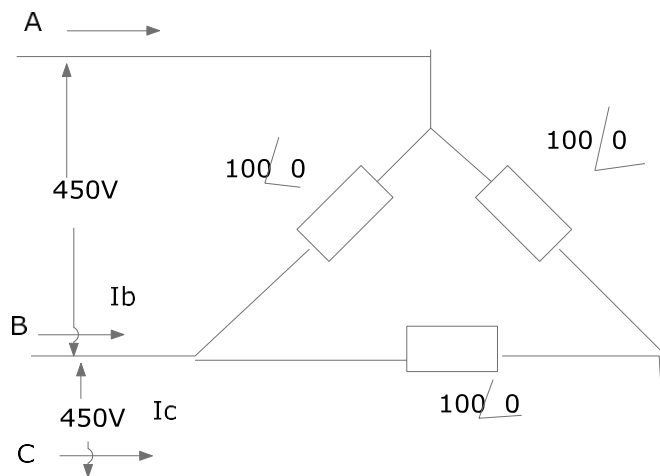

(2) Three phase power measurement

Slide 1

Q2. Sketch three phase power measurement by one watt meter method for balanced load

Slide 3+4+5+6

Q3. Sketch three phase power measurement by power analyser.

(3) Three phase 4 wires unbalanced

Slide 1+2+3

Q4. Three phase 240V ABC  $Z_a = 20 \angle -60^\circ \Omega$   $Z_b = 10 \angle -90^\circ \Omega$   $Z_c = 15 \angle 45^\circ \Omega$ . Find three phase power

Slide 5

Q5. Do the exercises on slide 5

(4) Three phase 4 wires system

Slide 1

Q6. Sketch three phase 4 wires system, indicate time & phase voltages. Write phase and line voltages & current equations.

Slide 2+3

Q7. Find line currents and neutral current.

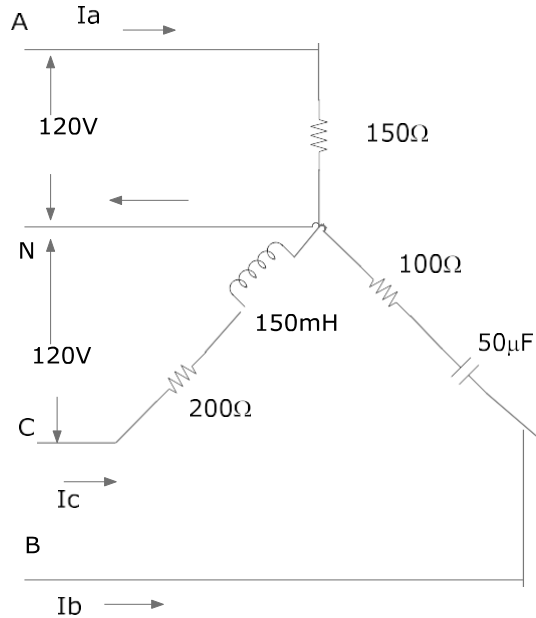

Slide 4+5

Q8. Explain the effect of broken neutral wire in three phase unbalanced system with necessary diagrams

Slide 6+7+8+9+10+11+12

Q9. A three phase 415V system's neutral wire is broken. The following line currents are flowing.

$$Z_a = 100 \angle 0^\circ \Omega \quad I_a = 2 \angle 8.5^\circ \text{ A}$$

$$Z_b = 150 \angle 0^\circ \Omega \quad I_b = 2 \angle -170^\circ \text{ A}$$

$$Z_c = 200 \angle 0^\circ \Omega \quad I_c = 2 \angle -30^\circ \text{ A}$$

- What are the new phase voltages
- What is the voltage between new star point and original star point
- Which phase got over voltage?

Q10. What is total power losses in resistors?

(3) Three phase three wires unbalanced

Slide 1+2

Q11. Three phase 415V  $Z_a = 10 \angle 60^\circ \Omega$   $Z_b = 15 \angle -90^\circ \Omega$   $Z_c = 15 \angle 30^\circ \Omega$  Find three phase power.

Slide 3+4

Q12. In above problem, if the phase sequence is ACB find total three phase power.

---

(6) Thevenin's theorem

Slide 1+2+3+4

Q13. Find current in AB.

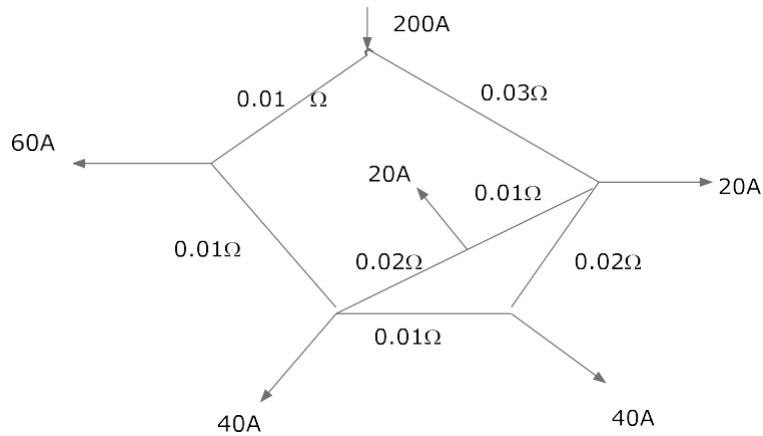

(7) Three phase star unbalanced

Slide 1+2+3+4+5+6

Q14. Three phase 415V star connected load has the following components

A phase—40 ohm resistor

B phase---50 ohm resistor

C phase -- -30 ohm resistor

Find (a) line current (b) Voltage between new star point and neutral point.

Slide 7

Q15

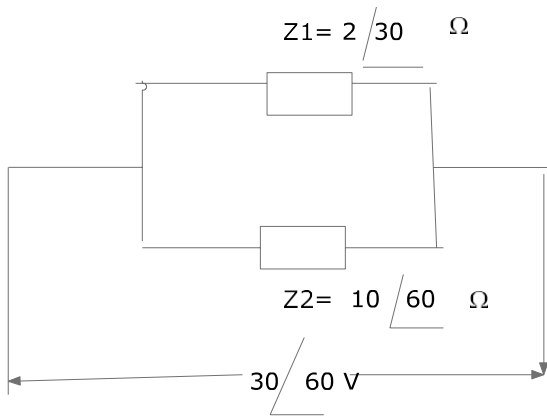

(8) Three phase delta total power

Slide 1+2+3

Q16.

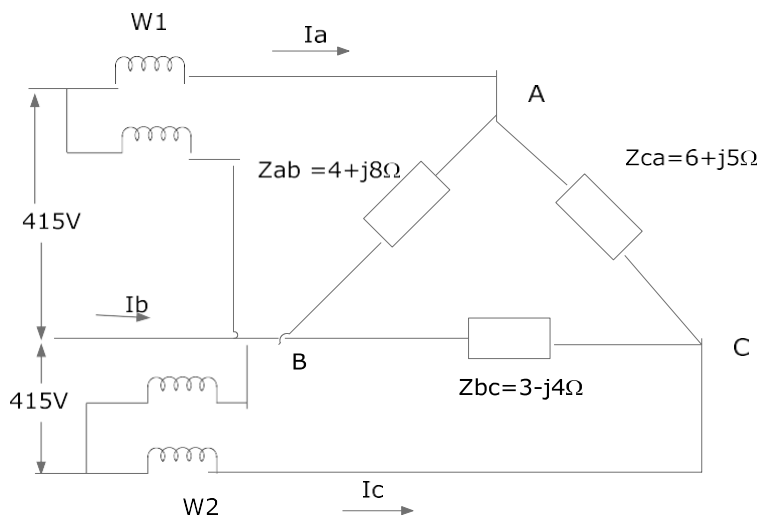

Sequence ABC

Calculate

- All line currents in polar form
- Reading of watt meter  $W_1$  &  $W_2$
- Total real power
- Total reactive power

(9) AC Circuit three phase problem

Slide 3+1+2

Q17. Do the exercises on the problems in slide 1,2,3

Q18. Find the currents  $I_a$ ,  $I_b$ ,  $I_c$  and power in three phase circuit.

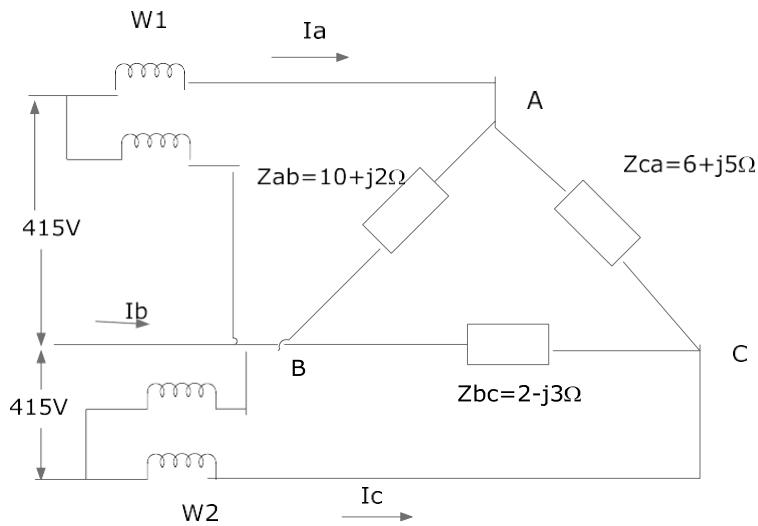

Sequence ABC

---

(10) J form

Slide 1+2+3+4+5+6

Q19. Sketch positive, negative and zero sequence currents

Q20. Write the equations for positive, negative and zero sequence currents of  $I_a$ ,  $I_b$  and  $I_c$

---

(11) Positive, negative and zero sequence

Slide 1+2+3+4

Q21.  $Z_1 = 20\%$   $Z_2 = 15\%$  200MVA base A to B fault at 33KV Find fault currents.

Slide 5

Q22.  $Z_1 = 5\%$   $Z_2 = 10\%$   $Z_0 = 20\%$ , 200MVA 132 KV line to ground fault. Find fault current.

Slide 6+7+8

Q23.  $Z_1 = 70\%$   $Z_2 = 70\%$   $Z_0 = 30\%$  Base MVA = 200 MVA  $E = 66KV$  2 Line to ground fault. Calculate fault current.

(12) Per unit system

Slide 1+2+3+4+5+6

Q24. In the given network, three phase fault occurs at point F. Calculate fault MVA per unit value of reactance. All refer to 200MVA base, resistance may be neglected.

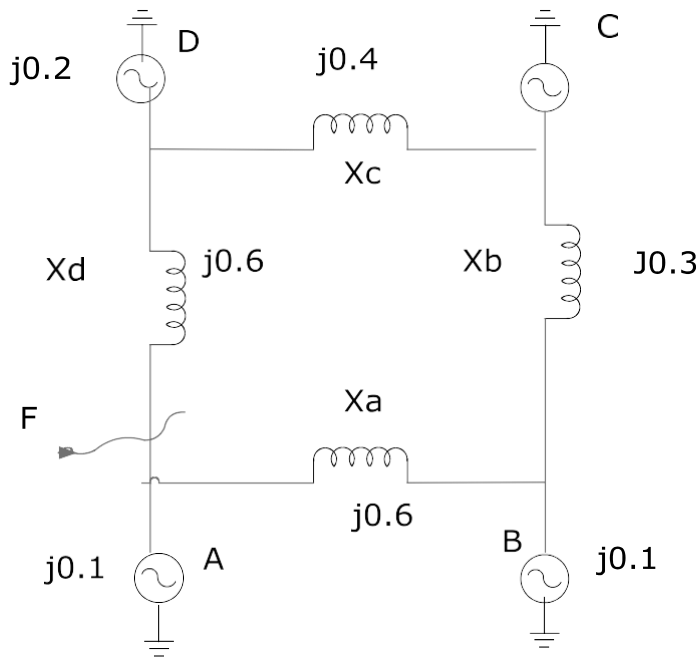

(13) Fault calculation

Slide 1 to 15

Q25. Draw the positive, negative and zero sequence equivalent diagram for the given power system.

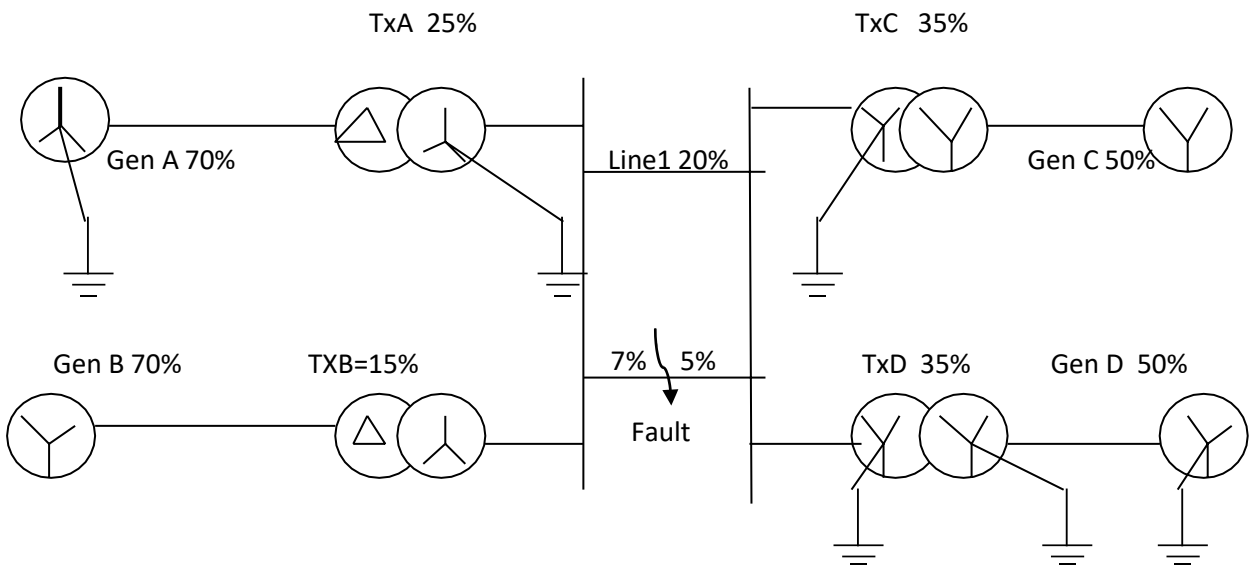

(14) 4 Terminals network, fault calculation problems

Slide 1+2+3

Q26. Determine the equivalent A, B, C, D constants of the network.

$A_1 = 2.0$     $B_1 = 30 / \underline{60} \Omega$     $C_1 = 0 \text{ mho}$     $D_1 = 2.0$   
 $A_2 = 2.0$     $B_2 = 0$     $C_2 = 0.01 / \underline{40} \text{ mho}$     $D_2 = 2.0$

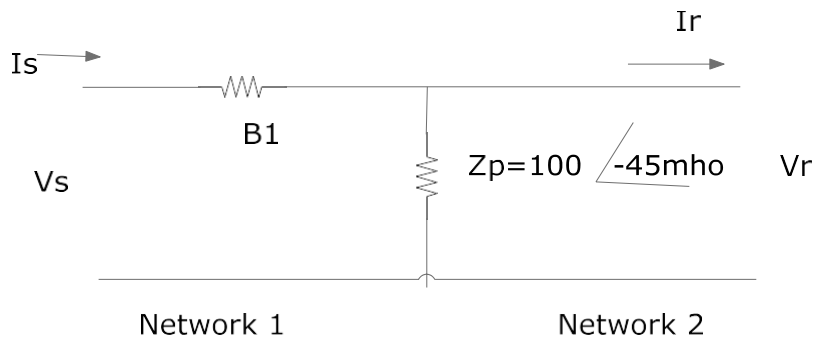

Slide 4+5+6

Q27. Determine the A, B, C, D constants of the network in which the following test results have been observed.

Receiver open circuit

$$V_s = 200 \angle 0 \text{ V}$$

$$V_r = 70.7 \angle -45 \text{ V}$$

$$I_s = 1.5 \angle -45 \text{ V}$$

Receiver short circuit

$$V_r = 0$$

$$V_s = 200 \angle 0 \text{ V}$$

$$I_s = 2 \angle -40 \text{ A}$$

$$I_r = 3 \angle -90 \text{ A}$$

Slide 7+8

Q28.  $I_a = 150 \angle 0 \text{ A}$   $I_b = 0 \text{ A}$   $I_c = 0 \text{ A}$  Find positive, negative and zero sequence currents

Slide 9+10+11

Q29. Find A, B, C, D constants of above Pi circuit

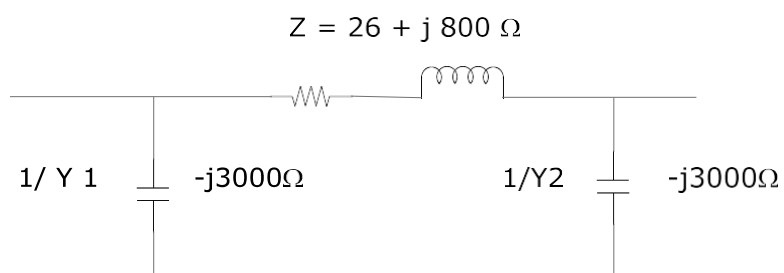

Slide 12+13+14+15+16+17

Q30. Do the exercises for slide 12

Q31.

Refer to the single line diagram below of the faulted power system.

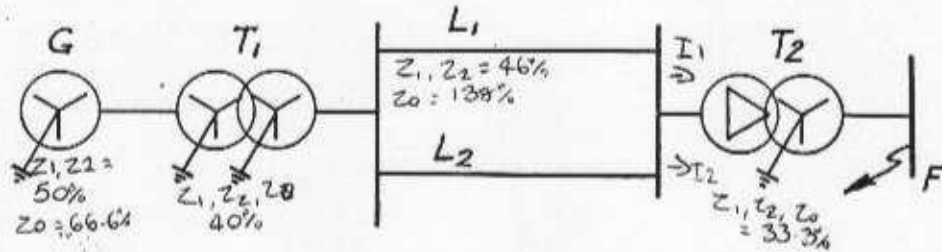

**Plant Details:**

Generator:	11kV, 30MVA, $Z_1 = Z_2 = 15\%$ , $Z_0 = 20\%$
Transformer T1	11kV/33kV, 30MVA, $Z = 12\%$ .
Transformer T2	33kV/11kV, 30MVA, $Z = 10\%$ .
Transmission Lines L1 and L2	Length 5kM, $Z_1 = Z_2 = +j1\Omega/\text{kM}$ , $Z_0 = +j3\Omega/\text{kM}$ .

Use a base for calculations of 100MVA.

- a) Draw positive, negative and zero sequence impedance diagrams for the system.

Calculate

- (a) Line to line fault current (b) Line to ground fault current (c) Two lines to ground fault current



G069+G070+E024

(1) Project management introduction

Slide 1

Q1.What is project management?

Slide 2+3

Q2.What are the important aspects of cycle of project management?

Q3.What are the steps in development of project life cycle?

Slide 4+5

Q4.What is technical meaning of project management?

Slide 6+7

Q5.Sketch the overview diagram of project management.

Slide 8+9+11

Q6.Explain the topology of project

Slide 10

Q7.Explain the management of expectations and perceptions in project management.

-----

(2) Strategies in project management

Slide 1+2

Q8.What are the strategies in project management?

Slide 3+4

Q9.Explain

- (a) Aggregate project plan
- (b) Trade off in project management
- (c) Various levels of skills for project
- (d) Reality

Q10.Which factors can contribute the failure of project?

-----

(3) Strategy objective

Slide 1+2

Q11.What are the developing of strategies in project?

Q12.How will you examine the effectiveness of activities in project management?

-----  
(4) Customer requirement

Slide 1+2+3

Q13.What factors can contribute customer's satisfaction?

Q14.What are the aspects in management of expectations and perceptions?

Slide 4

Q15.What are the steps in market research to develop and sell the products? Explain with flow diagram.

-----  
(5) Project system outline analysis

Slide 1+2+3

Q16.Explain the pre-processes in project planning.

Slide 4

Q17.Sketch project planning overview with function block diagrams.

Slide 5

Q18.Explain the steps and actions / activities in project planning.

Slide 6

Q19.Sketch the work breakdown diagram.

Slide 7+8

Q20.Explain project management in production of new product for marketing.

Slide 9

Q21.Differentiate project managers and line managers with diagram.

-----  
(6) Activity link

Slide 1+2+3

Q22. What are the Western's approach & Japanese's approach in project work?

Slide 4

Q23.Explain gate criteria

Slide 5

Q24.Explain the modelling of project system

Q25. Sketch project plan graphical form and explain (a) forward schedule (b) backward schedule.

Slide 7+8

Q26. Explain Gantt Chart for project

Slide 9+10+11+12+13

Q27. Explain the activity on arrow diagram & planning sequence.

---

(7) Project structure

Slide 1+2

Q28. Explain team & organization in project structure

Slide 3

Q29. Sketch the organization diagram for pure project organization

Q30. Explain (a) planning stage (b) execution stage of project

Stage 4

Q31. What is matrix management?

Slide 5+6

Q32. Explain (a) overlay model (b) secondment model of heavy weighted matrix & structure selection

Slide 7+8+9

Q33. Explain role and advantage, strength and weakness of managing personalities in team.

---

(8) Team effectiveness

Slide 1

Q34. What factors do contribute team effectiveness?

Slide 2

Q35. Explain analysis of plan

Slide 3

Q36. What are the numbers of ways to shorten the activities?

Slide 4+5+6+7

Q37. If a project requires the expenditure of \$ 300,000 now and will yield \$600,000 in 10 years. How will the manager evaluate whether or not this is viable?

Slide 8+9

Q38. Do exercise on slide 8+9

---

(9) Software development project

Slide 1

Q39. Sketch overview diagram of software development project.

Slide 2

Q40. Explain cost effectiveness analysis

Slide 3

Q41. Sketch the diagram to regulate worksheet.

Slide 4

Q42. What is decision tree?

Slide 5+6

Q43. Explain the selection of supplier using an weighted attributes.

Slide 7+8

Q44. Explain (a) Decision support expert system (b) Justification (c) Follow up action.

---

(10) Control of project

Slide 1

Q45. What are the rule of project managers?

Slide 2+3+4+5

Q46. What are the steps in quality auditing & control of major constraints in quality?

Slide 5+6

Q47. Sketch the flow diagram for quality system auditing and explain the process of implementing quality system.

Slide 7

Q48. Analyze the elements of quality cost.

Slide 8+9+10

Q49. Explain control of major constraints.

---

(11) Change control

Slide 1

Q50. Describe the overview of change control system.

Slide 2

Q51.Explain the establishment of contracts

Slide 3

Q52.Outline the project control system responding the disturbances.

Slide 4

Q53.Sketch the procedure for preparing quality manual.

Slide 5+6

Q54.Explain management leadership.

Slide 7+8

Q55.Explain (a) Individual motivation (b) Scientific management

---

(12) Problem solving and decision making

Slide 1

Q56.Explain the steps in management leadership

Slide 2+3

Q57.Explain problem solving and decision making.

Slide 4

Q58.What are the pre-planning of actions?

Slide 5+6+7

Q59.Sketch the flow diagram of systematic problem solving model.

Q60.Explain the modelling system for decision making.

---

(13) Management leadership

Slide 1+2+3

Q61.What are the factors affecting poor decision making?

Q62.How can individual skills & attitudes influence on decision making?

Slide 4+9

Q63.What are the steps in managing stress?

Slide 5

Q64.Explain (a) Time usage analysis (b) Techniques to keep the plan.

Slide 6+7

Q65. What are the factors that can impact on motivation?

Q66. Explain reinforcement

Slide 8

Q67. What are the cultural implications for project manager?

-----  
(14) Development of management thinking

Slide 1+2

Q68. What are the aspects in development of management thinking?

Slide 3

Q69. Explain the development of new management paradigms?

Slide 4

Q70. Explain project review

Slide 5+6+7+8

Q71. Explain the process after the completion of the project.

H011

(1) Power supplies

Slide 1

Q1. Sketch the overall block diagram of power supply.

Slide 2

Q2. Sketch (a) 1 phase half wave rectifier (b) bridge rectifier (c) centre tapped full wave rectifier.

Slide 3

Q3. Calculate the load resistance & capacitance size of a full wave rectifier that supplies 60V dc with 3% ripple voltage at 300mA to a resistance load. The rectifier circuit is supplied with 60HZ AC. Ripple frequency 150HZ.

Slide 4

Q4, What is voltage regulation?

Q5. Sketch series transistor regulator

Slide 5

Q6. Sketch regulator with feedback.

Slide 6+7

Q7. For the circuit in figure, calculate

- The maximum & minimum output voltage
- The current that will flow if output is short circuited
- The power dissipated by Q1 if the output is short circuited.

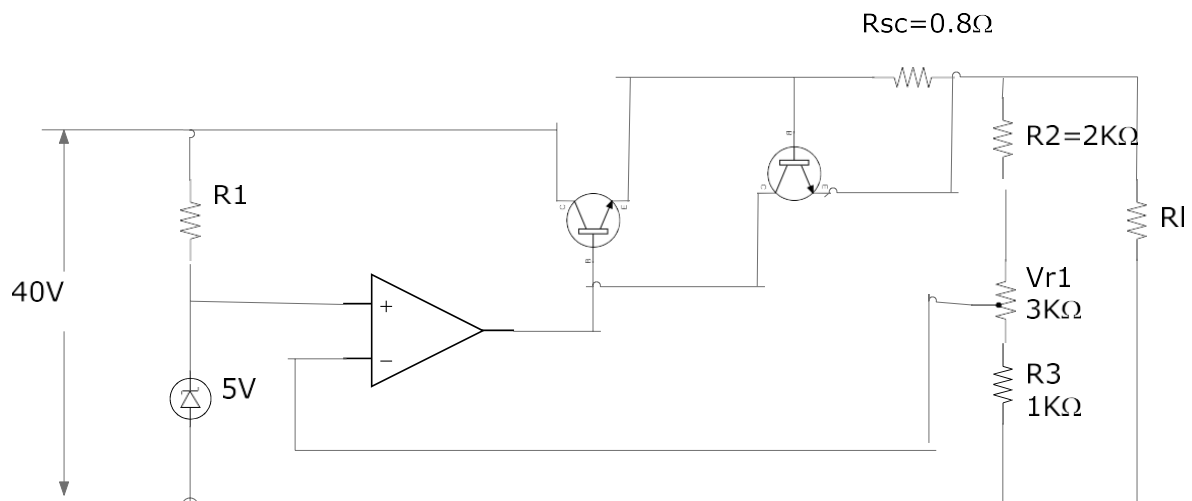

H012

(1) Digital introduction

Slide 1

Q1. What are the meanings of the followings?

CMOS, TTL, DTL, HTL, ECL

Slide 2 to 8

Q2. Sketch logic circuit, electrical circuit and truth table for (a) AND gate (b) NAND gate (c) NOR gate (d) NOT gate

-----  
(2) Logic gates

Slide 1+2+3

Q3. Do the exercises on slide 1+2+3

Slide 4 to 7

Q4. Do the exercises on slide 5

Slide 8

Q5. Do the exercises on slide 8

Slide 4+5

Q6. Find Z

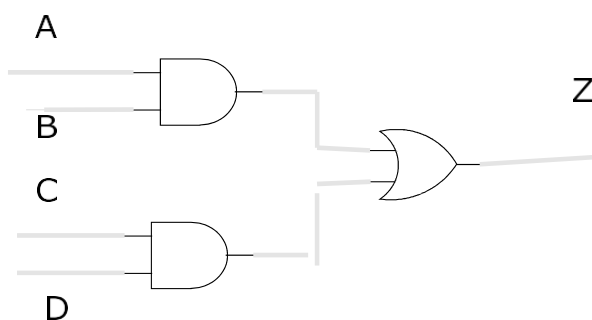
-----  
(3) Combinational logic + De-Morgan

Slide 1

Q7. In given logic diagram, which gate is faulty?



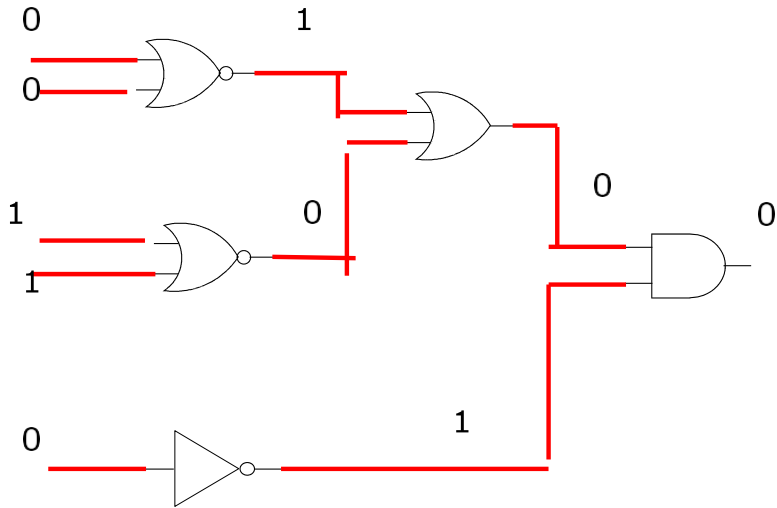

Slide 2

Q8. Find logic at U, V, W, X, Y

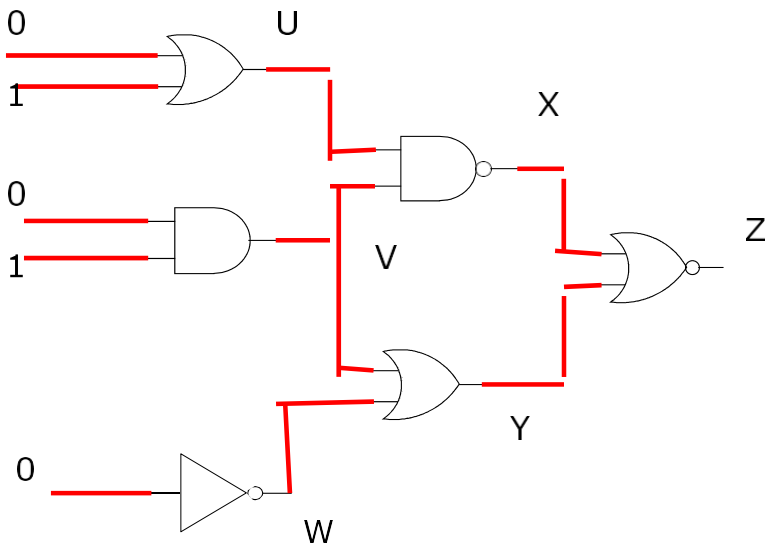

Slide 2+3

Q9. Do exercises on slide 2+3

Slide 4+5

Q10. Sketch logic gate for the followings

(a)  $(A \cdot C) + B$

(b)  $ABC + D$

(c)  $ABC + (\overline{AB}) + AC$

(d)  $\overline{(A+B)} \cdot C$

Slide 6+7+8

Q11. Do exercise on slide 6

Slide 9

Q12.Explain De-Morgan theorem

Slide 10

Q13.Sketch NAND and NOR equivalent of AND, NOT, OR gates

Slide 11+12

Q14.Do the exercises on slide 11

(4) Digital logic simplification

Q15. Write Boolean's expression for the given gates.

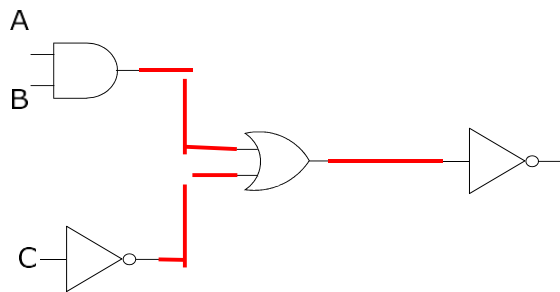

Slide 3+4+5

Q16.Do the exercises on slide 3+4

Slide 6

Q17.Simplify  $A + (A \cdot B)$

Q18.Simplify  $A(\overline{A+B})$

Q19.Simplify  $(A+B)(B+C)$

Slide 7+8+9+10

Q20. Simplify  $\overline{A \cdot B \cdot C} \cdot \overline{A} \cdot \overline{B} \cdot \overline{C}$

Slide 11+12

Q21.Do the exercises on slide 11+12

(5)Number system+ Display+ ADC +DAC

Slide 1

Q22.Convert 110110 to decimal

Slide 2

Q23. Convert  $135_{10}$  to binary

Slide 3+4

Q24. Sketch full adder and half adder.

Slide 5+6

Q25. Convert  $157_8$  to decimal.

Slide 7+8=13

Q26. Convert  $1100110_2$  to decimal.

Q27. Convert  $89_{10}$  to octal

Slide 9+10+11+14

Q28. Convert 5BF4 to binary

Slide 12+15

Q29. Convert 1111000101 to hexadecimal

Slide 16

Q30. Convert 8AF5 to binary

Slide 17+18

Q31. Do the exercises 1 to 7 on slide 17.

Slide 19 to 24

Q32. Subtract 101 from 1001 by 1's complement.

Slide 25+26

Q33. Subtract 1011 from 0110

Slide 27+28+29+30

Q34. Sketch alphanumeric display circuit.

Slide 31

Q33. Sketch digital to analogue conversion circuit.

Slide 32+33

Q36. Sketch analogue to digital conversion circuit.

H013

(1) Amplifier configuration

Slide 1+2

Q1. An amplifier develops 20W for input 5mW, calculate power gain in dB.

Q2. An amplifier fed with 100mV produces 5V output, calculate gain.

Slide 3

Q3. Sketch BJT transistor

Slide 4

Q4. Sketch diagram for the followings

(a) Transistor biasing (b) Darlington pair

Slide 5

Q5. Explain class A, B, AB and C amplifiers

Slide 6

Q6. Sketch transistor biasing circuit and label it.

---

(2) Multi stage + feedback + FET

Slide 1

Q7. Write the equation for multi stage cascaded amplifier & sketch block diagram of cascading.

Slide 2

Q8. Sketch RC coupling CE amplifier

Slide 3+4

Q9. Do the exercise in slide 3

Slide 5

Q10. What are the advantages of negative feedback?

Slide 6

Q11. Sketch examples of feedback.

Slide 7 to 11

Q12. Sketch diagram of voltage derived feedback and explain the benefits.

Slide 12

Q13. Sketch JFET

Slide 13+14+15

Q14.Explain operation of FET.

Slide 16+17

Q15.Do exercises on slide 16.

Slide 18 to 22

Q16.Explain FET

Q17.Describe

(a) DE MOSFET (b) E MOSFET (C)JFET

Slide 23+24

Q18.Sketch JFET-CS amplifier

Slide 25+26

Q19.Do the exercises on slide 25.

Q20.Sketch common drain JFET amplifier

Slide 27

Q21.Do the exercises on slide 27.

---

(3) Power output stage

Slide 1

Q22.What are the requirements of power output stage?

Slide 2

Q23.Sketch class A amplifier & explain characteristics.

Slide 3+4

Q24.Do the exercises in slide 3

Q25.Calculate input power required for industrial sound system with efficiency 25% output power 60KW.

Slide 7

Q26.What are the general features of class B amplifier.

Slide 8

Q27.Sketch class B amplifier circuit.

Q28.Do the exercises in slide 8

Slide 9

Q29. Do the exercises in slide 9

Slide 10

Q30. Explain class AB amplifier with sketch

Slide 11+12+13

Q31. Explain boost strapping

Slide 14

Q32. Sketch Darlington output transistor.

Slide 15

Q33. Sketch Quasi complementary amplifier.

---

(4) Power supply

Slide 1

Q34. Sketch block diagram of power supply.

Slide 2

Q35. Calculate load resistance and capacitor size of full wave rectifier that supplies 60V dc with 3% ripple voltage at 300mA resistive load, 50HZ AC.

Slide 3

Q36. Explain voltage regulator.

Slide 4+5+6

Q37. Explain series transistor regulator with sketch.

Slide 7+8

Q38. Do the exercises in slide 7

Slide 9

Q39. Sketch 5V power supply with 7805 IC.

---

(5) Power amplifier

Slide 1+2

Q40.



Calculate (a) Voltage gain (b) Input current (c) Output current (d) Current gain (e) Output power (f) Power gain (g) Transresistance (h) Transconductance

Slide 3+4

Q41. Find dBt & AVt

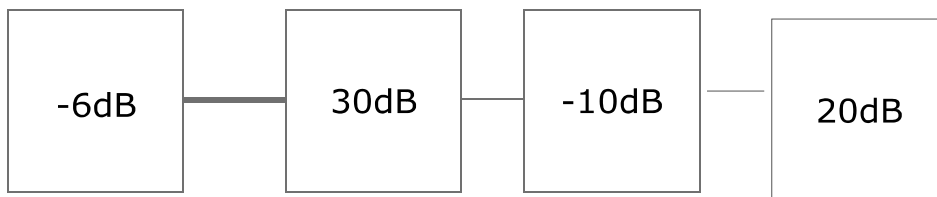

Slide 5+6+7+8

Q42. Sketch (a) Equivalent circuit (b) Input voltage (c) Output voltage (d) Voltage gain

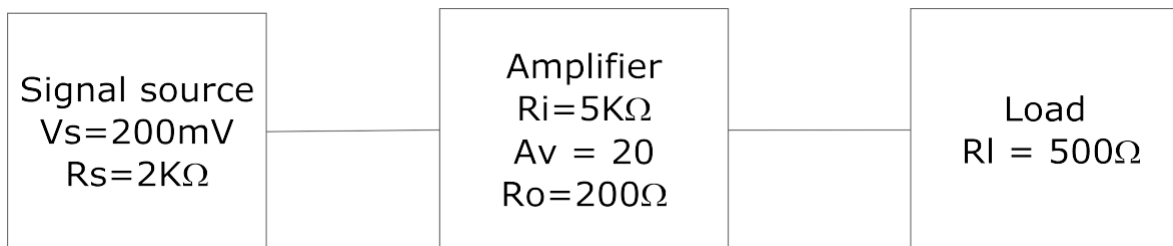

Slide 9+10+11

Q43. Do the exercise in slide 9

Slide 12

Q44. An amplifier has input impedance  $20\text{K}\Omega$ . Calculate the value of coupling capacitor required for  $50\text{Hz}$  lower  $-3\text{dB}$  frequency, source resistance  $500\Omega$ .

(6) Operational amplifier calculation

Slide 1 to 7

Q45. Do the exercises in slide 1

Slide 8

Q46. Sketch the diagram to develop basic PWM.

Slide 9

Q47. Calculate minimum & maximum voltage gain.

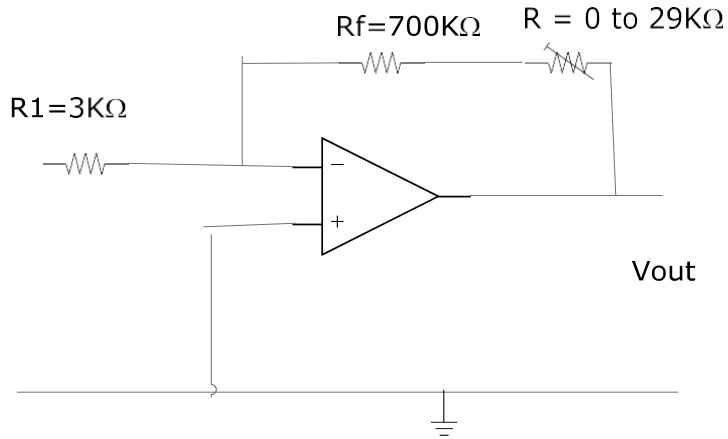

Slide 10+12

Q48. Find  $I_1$  and  $I_5$

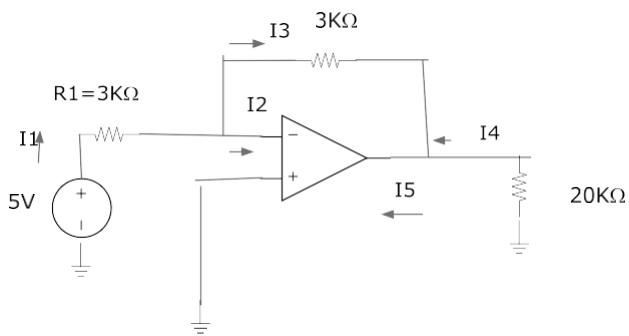

Slide 11+13+14

Q49. Find  $R_{in}$ .

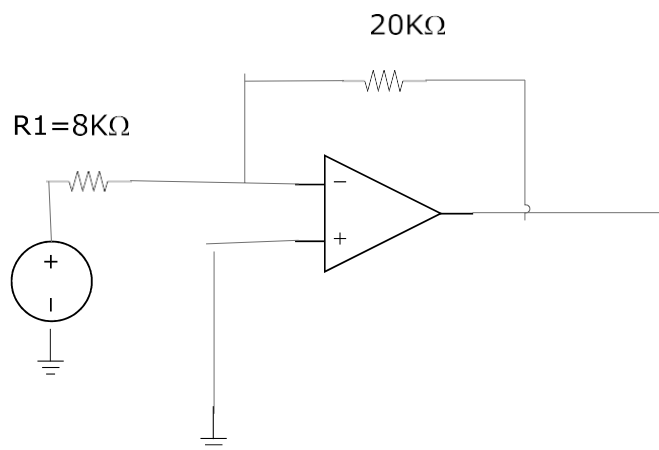

Slide 15+16

Q50. Calculate  $V_o$ .



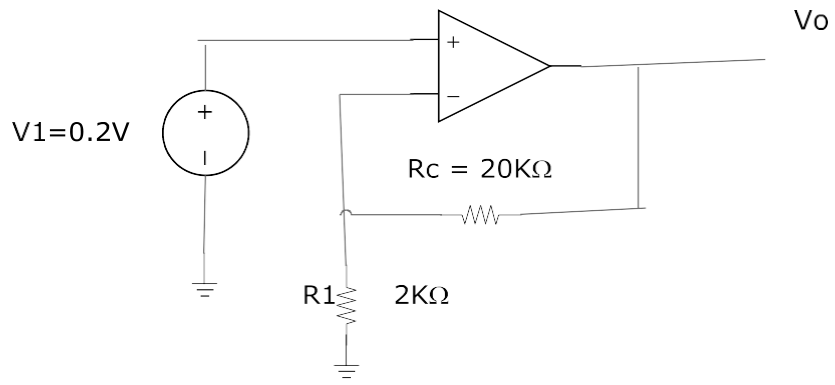

H025

(1) DC Condition –Op-Amp

Slide 1

Q1. Write the equations for dc condition of differential amplifier.

Slide 2

Q2. Write the equation for voltage gain of differential amplifier.

Slide 3+4

Q3. Determine the voltages present at the base, collector and emitter terminals for both transistors in the circuit.

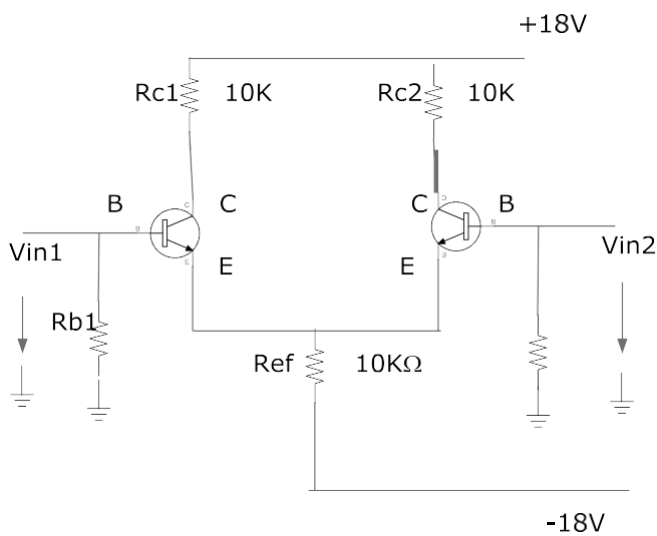

Slide 5

Q4. Sketch the block diagram for tacho motor speed control system by using differential amplifier.

Slide 6+7

Q5. Calculate (a) Vr2 (b) Vr3 (c) Ic

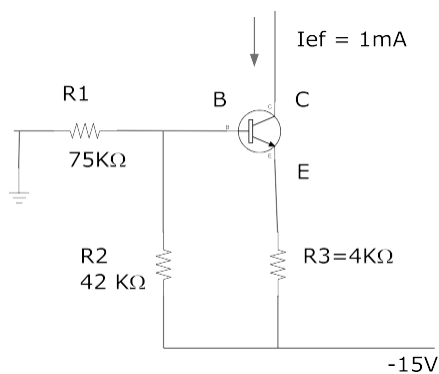

Slide 8

Q6. Sketch the operational amplifier with inverting and non inverting input and power supply output.

Slide 9

Q7.Sketch AD 584 comparator

Slide 10

Q8.Sketch the basic non inverting comparator circuit.

Slide 11

Q9.Write the equation for open loop voltage gain .

Slide 12+13

Q10.Sketch inverting amplifier with positive feedback.

Slide 14+15

Q11.Sketch output waveform of Schmitt comparator & explain its operation.

Slide 16

Q12.Sketch LM311 IC interfacing to digital logic.

Slide 17 to 22

Q13.Do the exercises in slide 17+18+19

(2) Monostable circuit, inverting

Slide 1+2

Q14.Sketch monostable circuit.

Slide 3+4+5

Q15.For given circuit, calculate on time delay.

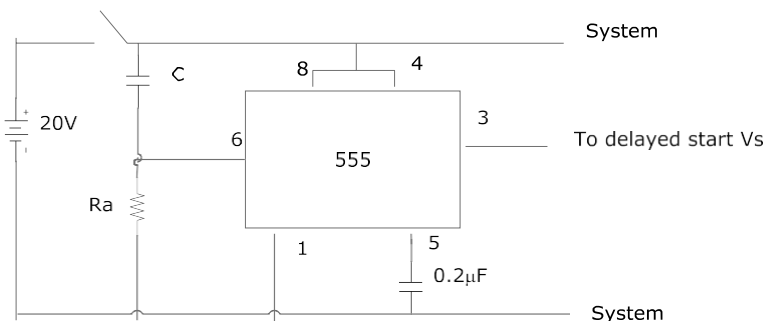

Q16.Explain timer circuit for induction motor.

Slide 6+7+8

Q17.Sketch operational amplifier /ideal inverting amplifier & explain the operation.

Slide 9+10

Q18.Explain inverting amplifier with sketch.

Slide 11

Q19.Sketch & explain voltage follower.

Slide 12

Q20.Assuming ideal op-amp, determine the voltage gain and output voltage for each circuit.

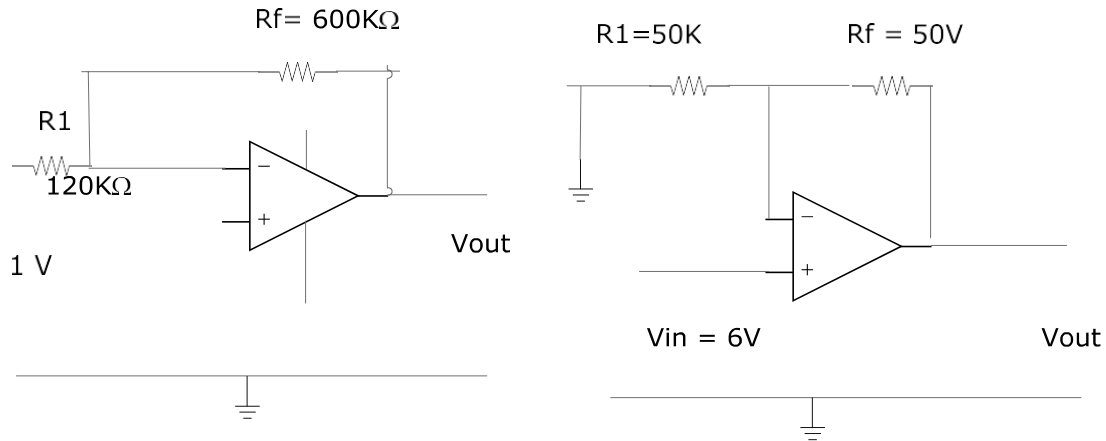

Slide 13+14+15+16

Q21.For given circuit

- Calculate  $I_{r1}$   $I_{r2}$   $I_{r3}$  and  $I_f$
- Voltage gain of each input channel
- Output voltage
- $V_{in1} = 0.7V$  ,  $V_{in2} = -0.2V$  ,  $V_{in3} = +7V$

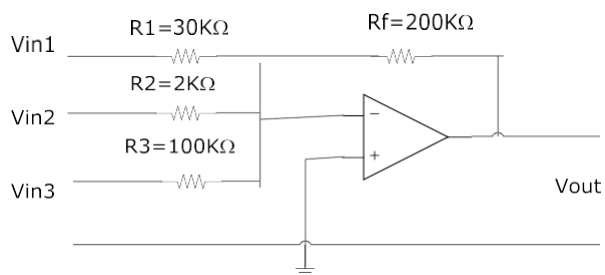

Slide 17+18

Q22.In given circuit(a) Calculate differential voltage gain (b) Output voltage

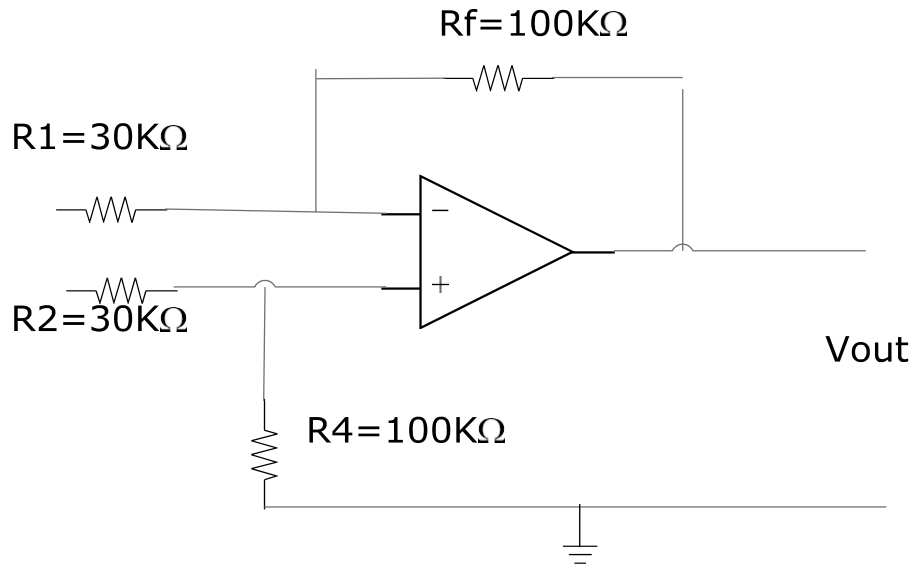

Slide 19+20

Q23. Find  $A_v$  total &  $V_{out}$

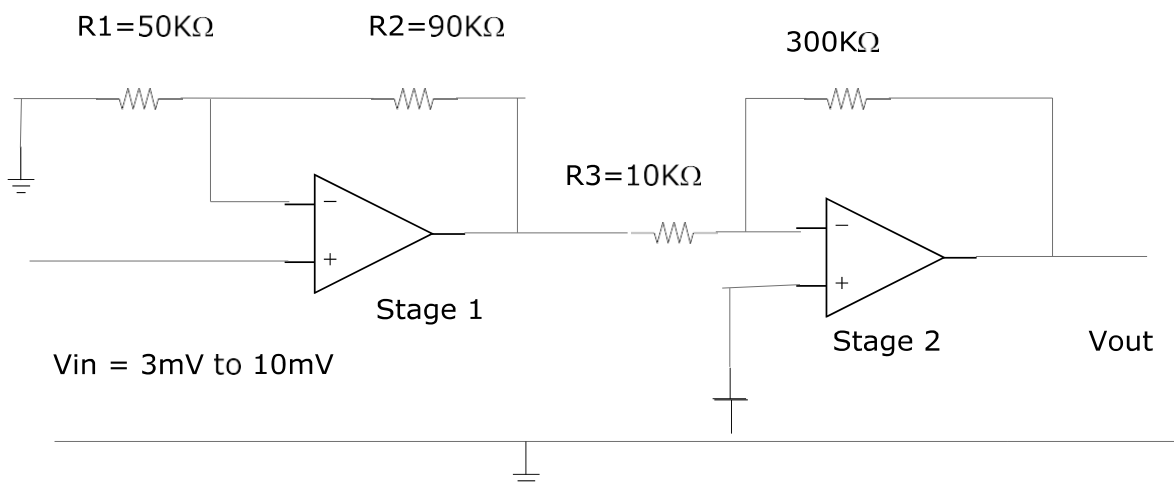

Slide 21

Q24. What are limitations for Op-amp?

Slide 22

Q25. How will you offset the input offset current?

Slide 23

Q26. For given circuit, find the value of offset minimizing resistor.

(a)

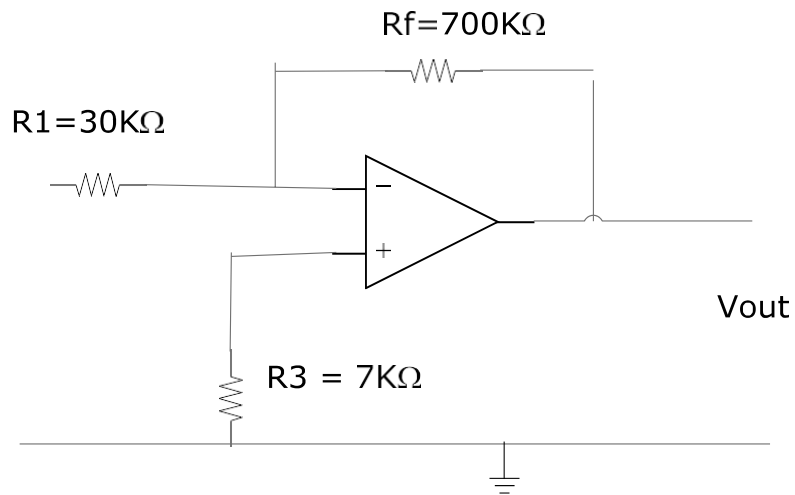

(b)

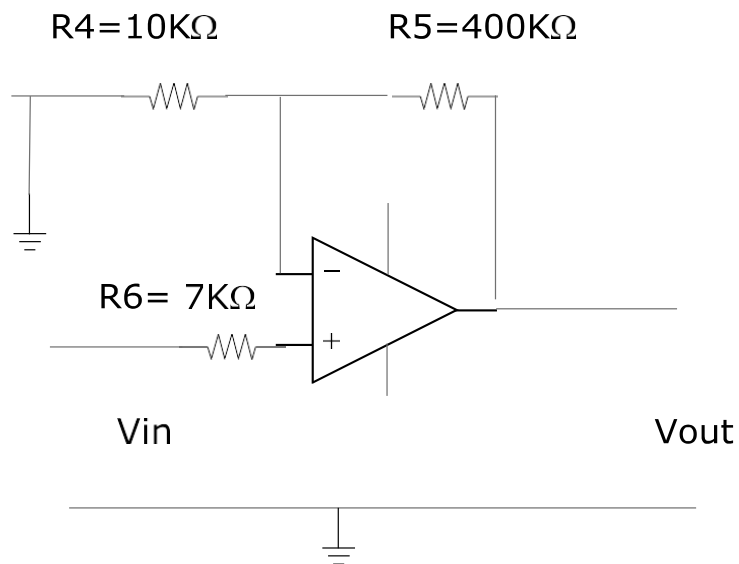

Slide 24

Q27.Explain CMRR / Noise output voltage

Slide 25+26+27+28

Q28.Explain time delay starter for three phase motor.

(3) Op-amp characteristics and bandwidth compensation.

Slide 1

Q29.What is frequency response of op-amp?

Slide 2+4

Q30.Explain bandwidth

Slide 3

Q31.If dB of amplifier is 3, calculate voltage gain.

Slide 4

Q32.Sketch inverting amplifier and non inverting amplifier circuits for  $180^\circ$  phase shift and  $0^\circ$  phase shift .

Slide 5+6+7

Q33.Explain frequency compensation and explain single capacitor compensation and feedforward compensation.

Q34.The UGB for 741 Op-amp is 2MHZ & 10MHZ for LF 411. If closed loop voltage gain is 200, calculate bandwidth.

Slide 8

Q35.Explain slew rate.

Slide 9

Q36.If 4V p-p square wave at a frequency of 100KHZ is applied to a voltage follower with a slew rate  $1/\mu\text{S}$ . Calculate (a) Period of waveform (b) Time taken to charge by 3V.

Slide 10

Q37.What is slew rate limiting of sine wave?

Slide 11+12

Q38.The slew rate of 741 is  $1\text{V} / \mu\text{S}$ . It is configured as a voltage follower. Determine the maximum frequency that can be obtained from the circuit for the following voltages.

(a) A 40 V p-p sine wave

(b) A 4 V p-p sine wave

Q39.Determine the bandwidth of an inverting amplifier with a closed loop gain of (-) 200. That is constructed with an internally compensated Op-amp that has a unity gain bandwidth of 4MHz

Slide 13

Q40.Determine the slew rate of the Op-amp whose output response to a square wave is shown in figure.

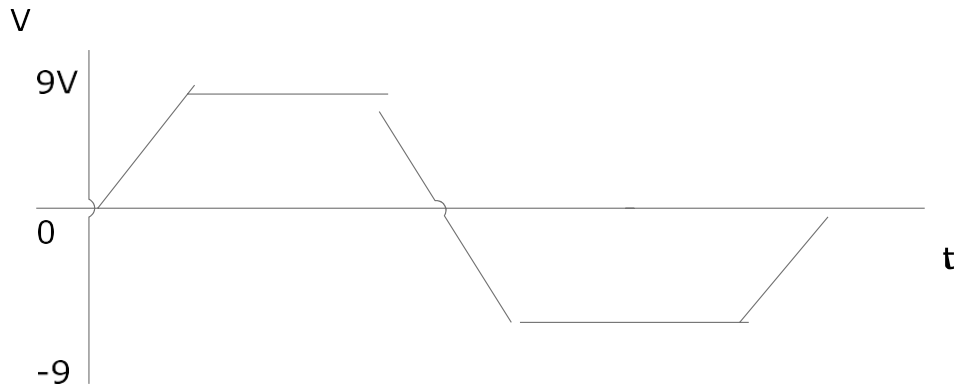

Slide 14+15

Q41. The given circuit is a non-inverting amplifier constructed with a 741 Op-amp. Slew rate is  $0.7\text{V}/\mu\text{S}$ . Unity gain bandwidth =  $2\text{MHz}$ . Determine (a) The bandwidth of circuit (b) Maximum peak to peak output voltage.

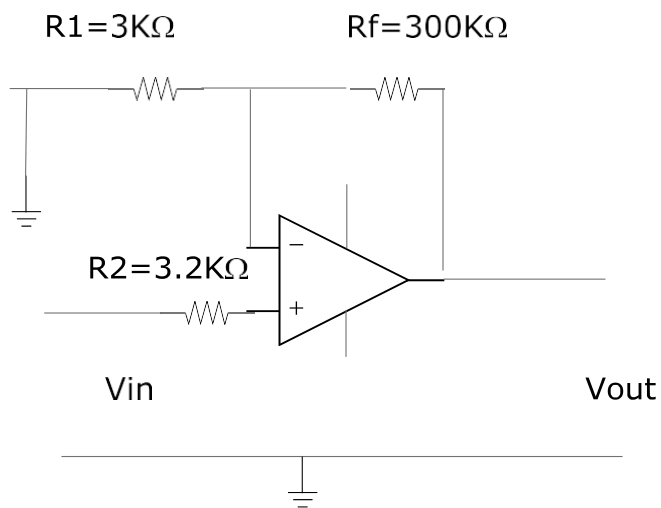

Slide 16+17+18+19

Q42. Explain variable frequency speed control & PWM.

(4) Op-amp Diode Rectifier

Slide 1

Q43. Explain the characteristics of op-amp diode with diagram.

Slide 2+3+4

Q44. Explain precision full wave rectifier.

Q45. What is limiting current?

Slide 5

Q46. Explain unipolar limiter and bipolar limiter with sketch.

Slide 6+7+8+9+10



Q47. Sketch precision clipper, peak detector, sine and square wave oscillator, non symmetrical astable circuit and phase shift oscillator.

Slide 11+12+13

Q48. Sketch op-amp RC circuit , basic differentiator , integrator & differentiator.

Slide 14

Q49. for the given circuit, calculate the output voltage after 3 ms if -6V is applied to the input.

Assume the output voltage was 0V prior connecting -10V input.

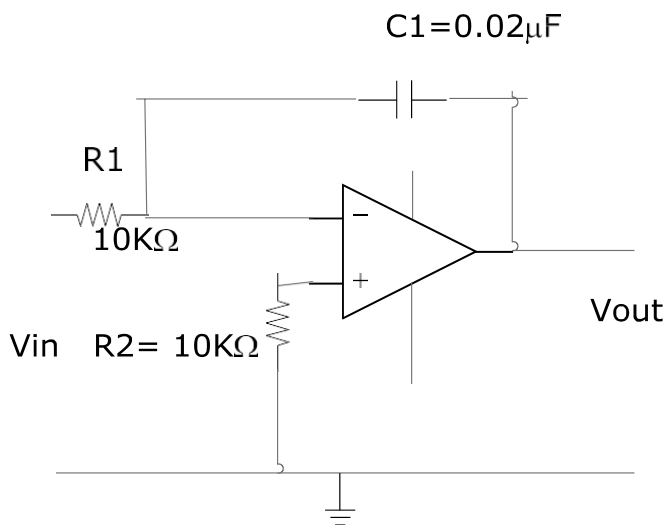

Slide 15

Q50. Sketch the circuit of function generator and waveform.

(5) Active filter

Slide 1

Q51. What is active filter?

Slide 2+3

Q52. What are the frequency response of filters and sketch (a) Low pass filter (b) High pass filter?

Slide 4 to 12

Q53. Sketch second order low pass butter worth filter & band pass filter, band stop filter.

Q54. (a) Calculate the cut-off frequency  $f_H$  (b) Sketch the frequency response indicating the relative output level.

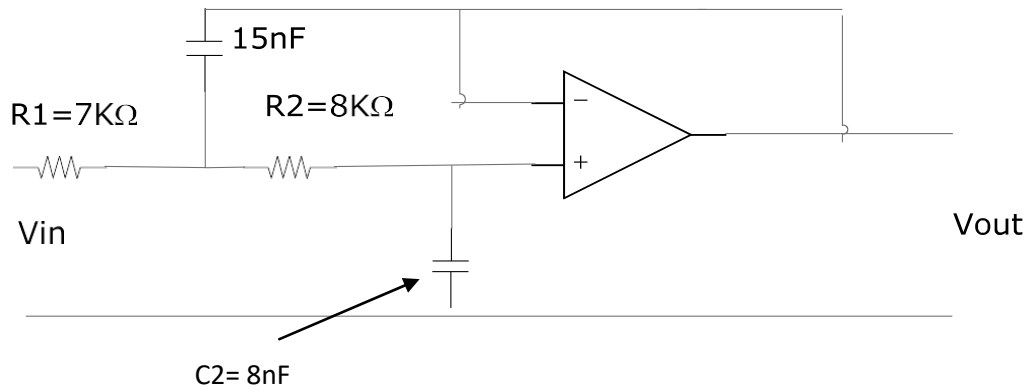

Q55. Calculate (a) the cut off frequency  $f_l$  (b) Sketch frequency response.

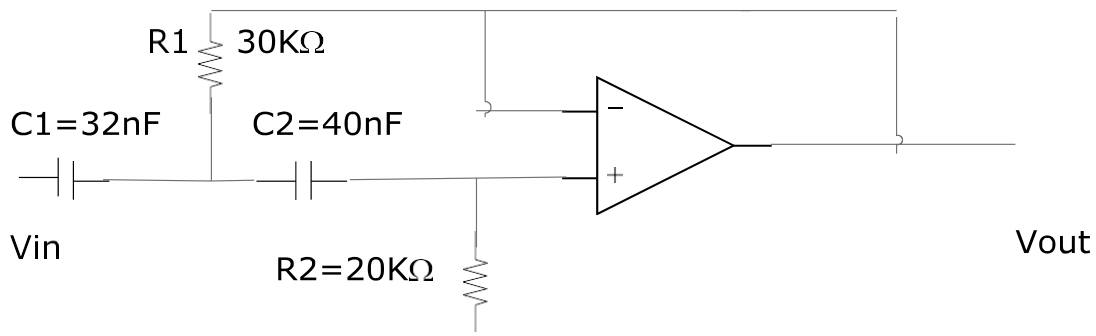

Q56. (a) Calculate the cut off frequencies  $f_l$  &  $f_H$  (b) Sketch the frequency response indicating the relative output levels  $f_L$  &  $f_H$

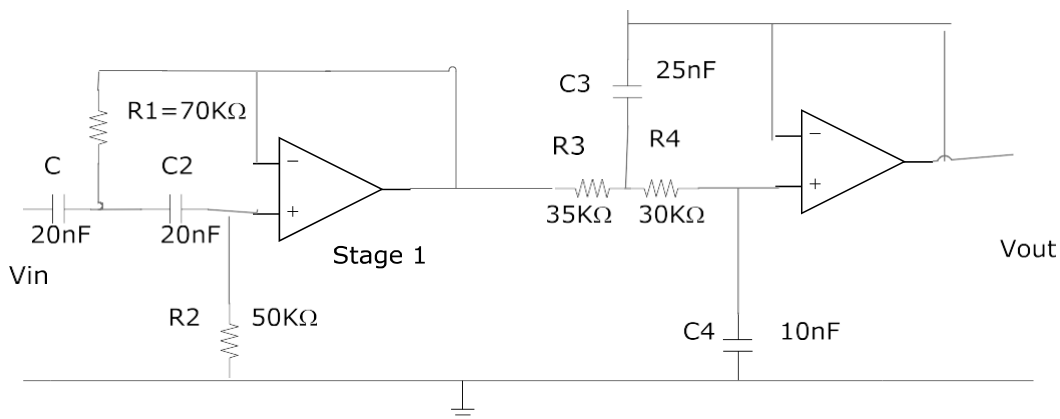

Slide 13+14

Q57. Sketch light level indicator.

Slide 15+16+17

Q58. Sketch sample and hold circuit.

(6) Industrial transducer

Slide 1

Q59. What is industrial transducer?

Q60. Sketch closed loop control system.

Slide 2

Q61. Sketch the block diagram of PLC system.

Slide 3

Q62. Explain transducers and sensors

Slide 4

Q63. What are the forms of energy?

Slide 5

Q64. Define (a) Range (b) Span (c) Linearity (d) Sensitivity (e) Resolution

Slide 6

Q65. Explain temperature measurement.

Slide 7

Q66. Explain RTD with sketch

Slide 8+9

Q67. Explain thermistor, thermocouple

Slide 10

Q68. Explain force measurement

Slide 11

Q69. Explain tachogenerator, encoder

Slide 12+13+14

Q70. Explain position measurement

Slide 15+16+17+18+19

Q71. Explain final control elements

---

(7) Solid state switching control

Slide 1+2+3

Q72. Explain solid state switching devices. BJT, SCR, Triac

Slide 4+5

Q73. Explain phase control circuit by diac and triac with sketch.

Slide 6+7+8

Q74.Explain control system.

Slide 9+10+11+12

Q75.Explain open loop & closed loop control system

Slide 13

Q76.Explain (a) two positions control (b) proportional control.

Slide 14+15+16+17

Q77.Explain accuracy in control system.

Slide 18+19

Q78.Explain (a) multiplexing (b) power op-amp

Slide 20

Q79.Explain motor speed control with sketch

Slide 21+22+23+24

Q80.Do the exercises on slides.

H026

(1) Variable speed drive

Slide 1+2+3+4

Q1.Explain variable frequency speed control method.

-----

(2) Converter

Slide 1+2+3+4

Q2.Explain PWM controlled DC-DC converter

-----

(3) Rectifier

Slide 1+2

Q3.Explain AC to DC rectification system.

-----

(4) Chopper circuit+ Bridge rectifier +SCR drive

Slide 1+2+3

Q4.Explain chopper circuit.

Slide 4

Q5.Explain DC drive control loop.

Slide 5 to 12

Q6.Explain the followings with sketches.

(a) Class A chopper (b) Class B chopper (c) Class C chopper (d) Class E chopper

Slide 13

Q7.Sketch three phase rectifier bridge and voltage & current waveform.

Slide 14+15+16

Q8.Explain the operation principle of power SCR.

Slide 17

Q9.Explain PF correction of SCR drive motor.

(5) Three phase variable drive system

Slide 1+2

Q10.Explain three phase variable frequency drive system .

---

(6) Power diode & SCR

Slide 1+2+3+4

Q11. Explain power diode with sketch.

---

(7) Power SCR

Slide 1 to 8

Q12. Explain construction & operation of power SCR with sketches.

Slide 4

Q13. Explain the application of free wheeling diode with sketch.

---

(8) AC-DC converter

Slide 1 to 7

Q14. Explain the basic dc-dc converter (or) chopper circuit. Explain the application in driving and braking

Slide 8+9

Q15. Describe the rating of power electronics devices for various applications.

---

(9) Three phase bridge rectifier SCR circuit

Slide 1

Q16. Explain the application of power SCR connection for variable drive system.

Slide 2+3+8+9

Q17. The following three phase converter is connected to three phase 500V 50HZ source. The load consists of a 600V dc source having an internal resistance  $3\Omega$ . Calculate the power applied to the load for triggering delay of (a)  $30^\circ$  (b)  $45^\circ$ .

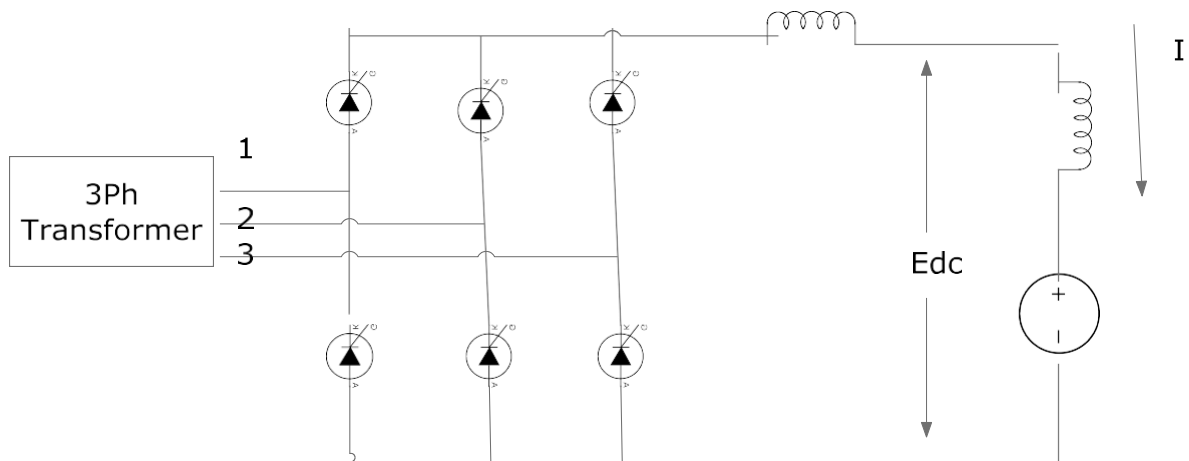

Slide 4+5+6+7

Q18.Explain the concept of delayed triggering angle.

Slide 10+11+12

Q19.Explain variable voltage speed control of squirrel cage induction motor.

---

(10) Variable voltage variable frequency

Slide 1

Q20.Explain variable voltage variable frequency control system.

---

(11) Pulse width modulator

Slide 1 to 6

Q21.Explain the rectification & inverting tasks executed by SCR for induction motor & synchronous motor.

Slide 7

Q22.Explain single phase current source inverter bridge with sketch of circuit diagram and wave forms.

Slide 8

Q23.Sketch the circuit connection of PWM inverter bridge & waveforms.

Slide 9+10

Q24.Sketch control of six step current source drive.

---

(12) Current fed inverter

Slide 1

Q25. Sketch the circuit of current fed inverter.

Slide 2+3

Q26. Sketch the circuit of voltage fed square wave drive circuit.

Slide 4

Q27. What is absolute value of 7<sup>th</sup> and 9<sup>th</sup> harmonics.



H045

(1) Basic operational amplifier circuits

Slide 1+2

Q1. Explain the basic operational amplifier circuit, ideal op-amp, linear amplifier with negative feedback.

Slide 3

Q2. Explain non inverting amplifier.

Slide 4

Q3.

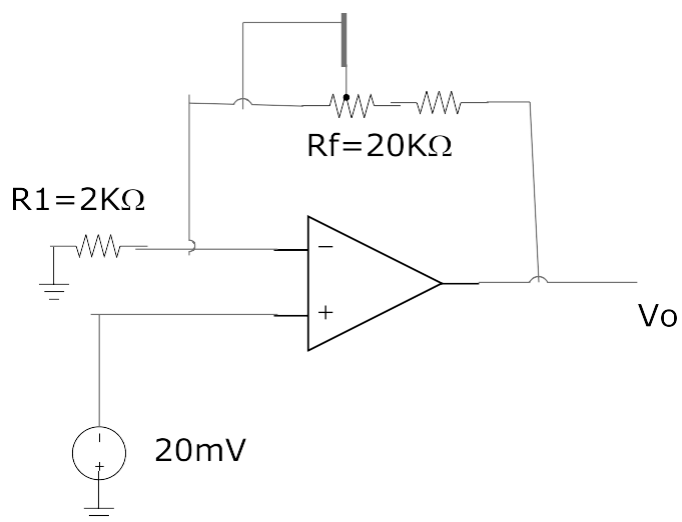

- (a) What is minimum voltage gain of the circuit?
- (b) To get the voltage gain 101, what is the resistance of potentiometer?
- (c) What is the signal current drawn from source?
- (d) If the voltage gain is 40, what is output voltage?
- 

(2) Analog amplifier configuration

Slide 1

Q4. Sketch voltage follower.

Slide 2

Q5. In the following circuit, the D to A converter gives an output current in the range 0 to 2.8mA. Select  $R_f$  to give output voltage range 0 to 10V.

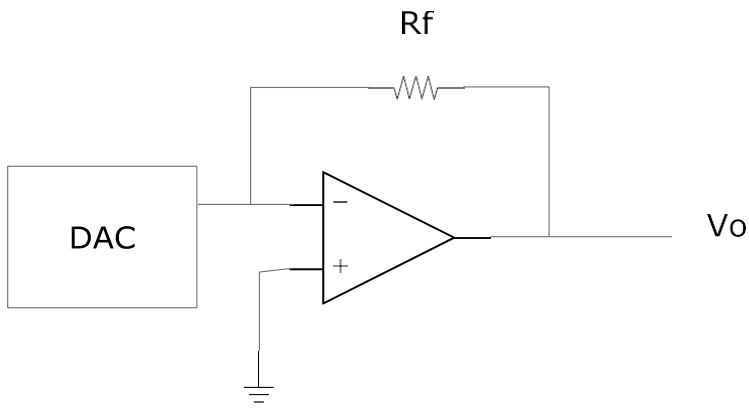

Slide 3

Q6

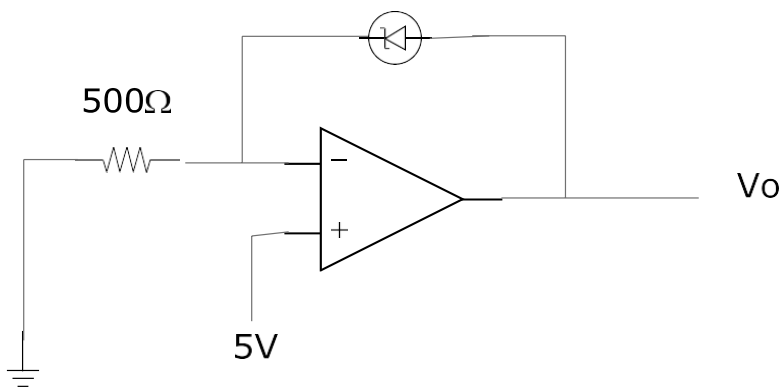

- If the diode forward bias or reverse bias
- Calculate diode current
- Calculate output voltage if diode drop is 500mV

Slide 4

Q7. Sketch the power supply connection for op-amp

Slide 6+7+8

Q8. Explain input offset voltage.

Slide 9

Q9. Sketch bias current compensation circuit.

(3) Inverting / Non inverting amplifier

Slide 1

Q10.Explain the drift in output dc offset due to change of temperature .

Slide 2+3+4

Q11.A biased compensated amplifier has  $R_f = 200\text{K}\Omega$  &  $R_1 = 2000\Omega$ . The maximum drift in output offset voltage is  $50\mu\text{V}/^\circ\text{C}$ . The maximum drift in input offset current is  $600\text{pA}/^\circ\text{C}$ . If the circuit is nulled at  $20^\circ\text{C}$  what is the worst case output dc offset voltage at  $90^\circ\text{C}$ .

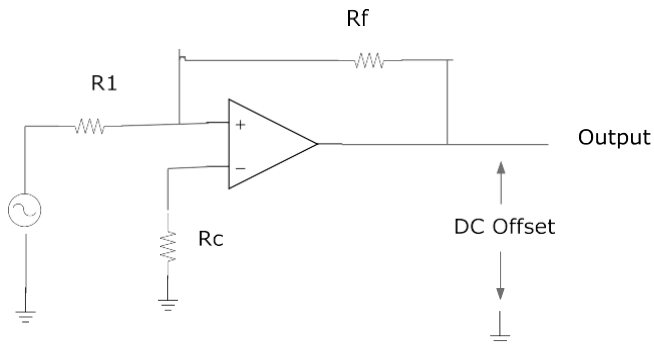

Slide 5+6+7

Q12.If power supply rejection of op-amp is  $100\text{dB}$  & supply voltage is changed by  $3\text{V}$ , what will be change in output dc voltage?

---

(4) Slew rate

Slide 1+2

Q13.What are the causes of slew rate & method to improve it?

Slide 3+4

Q14.Sketch the effect of slew rate on square wave response & sine wave response.

Slide 5

Q15.Sketch the circuit to improve slew rate.

---

(5) Noise model for op-amp

Slide 1

Q16.Explain the noise model for op-amp.

Slide 2+3

Q17.Explain the description & calculation of noise.

Slide 4+5

Q18.If op-amp is stated to have a noise voltage density of  $20\text{ nV} / \sqrt{1+z}$

Find RMS noise voltage over bandwidth  $40\text{KHZ}$ .

Q19. The noise current density of 741 op-amp is  $4 \times 10^{-30} \text{ A}^2/\text{HZ}$ . Find RMS noise current over 40KHZ bandwidth.

Q20. The noise voltage of an amplifier is  $8\mu\text{V}$  over 50KHZ bandwidth. If bandwidth is changed to 20KHZ, calculate noise voltage.

Slide 6

Q21. In an operational amplifier, the source noise reference = 40KHZ. Thermal noise due to source resistance =  $3.8\mu\text{V}$ . Internal noise current 80PA, internal noise voltage  $5.1\mu\text{V}$ .

- (a) What is equivalent input noise voltage  $e_n$  ?
- (b) What will be new value of noise at tripped bandwidth?

-----

(6) Method to improve noise performance

Slide 1

Q17. Describe the methods to improve noise performance.

Slide 2

Q18. Explain gain and phase response of op-amp.

Slide 4+5+6

Q20. Explain the stability of negative feedback circuit and graphical determination of amplifier stability.

Slide 7+8+9

Q21. Do the community exercise on slide 7

-----

(7) Phase margin & closed loop bandwidth

Slide 1

Q22. Explain phase margin & closed loop bandwidth.

Slide 2+3+4+5+6

Q23. Do the exercise for the problem in slide 2.

Slide 7+8

Q24. Explain over damp/under damp/ critical damp.

-----

(8) Compensation capacitor+ critical damping

Slide 1+2+3

Q25.Explain frequency compensation, case of damping, internal & external compensation . Sketch the connection of compensation capacitor.

Slide 4

Q26.How are the bandwidth & slew rate effected?

Slide 6

Q27.Sketch the capacitor compensation circuit and explain characteristics.

Slide 7+8

Q28.Sketch feed-forward compensation circuit & explain.

-----

(9) Bandwidth, slew rate, non inverting

Slide 1+2+3+4

Q29.A non inverting amplifier has a voltage gain of 30. When the input voltage is 20mV p-p square wave, the 10% to 80%. Rise time was  $4\mu\text{S}$ . When the input was increased to 2V, the output 10 to 80%. Rise time increased to  $14\mu\text{S}$ . Calculate (a) small signal bandwidth (b) slew rate (c) gain bandwidth product (d) rise time due to slew rate (e) If gain is adjusted to 0.5 sec, the new small signal rise time.

-----

(10) Instrumentation amplifier

Slide 1+2+3+4+5

Q30.Sketch instrumentation amplifier & explain the operation & applications.

Slide 6

Q31.Sketch a bandwidth substractor with buffer amplifiers operating with gain.

-----

(11) Construction of analogue electronic circuits

Slide 2

Q32. Calculate the cut-off frequency  $f_1$  of the circuit.

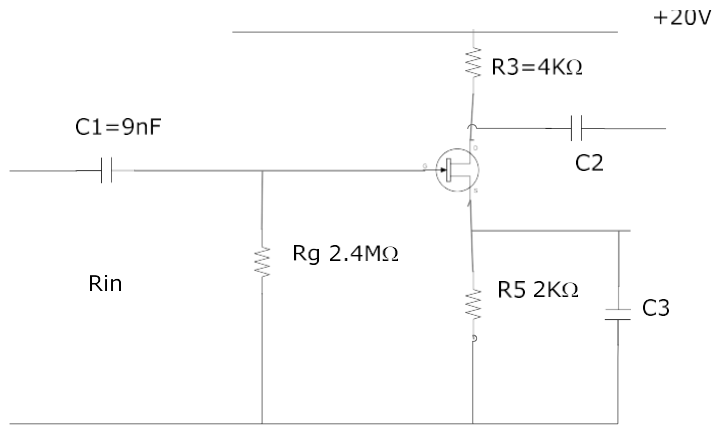

Slide 3

Q33. Sketch capacitor coupled multi stage amplifier

Slide 4 to 8

Q34. Do the exercise for time problem in slide 4.

Slide 9

Q35. Sketch transformer coupled amplifier circuit.

Slide 10+11+12

Q36. Calculate  $I_{b1}$ ,  $I_{c1}$ ,  $I_{e1}$ ,  $I_{b2}$ ,  $I_{c2}$ ,  $I_{e2}$

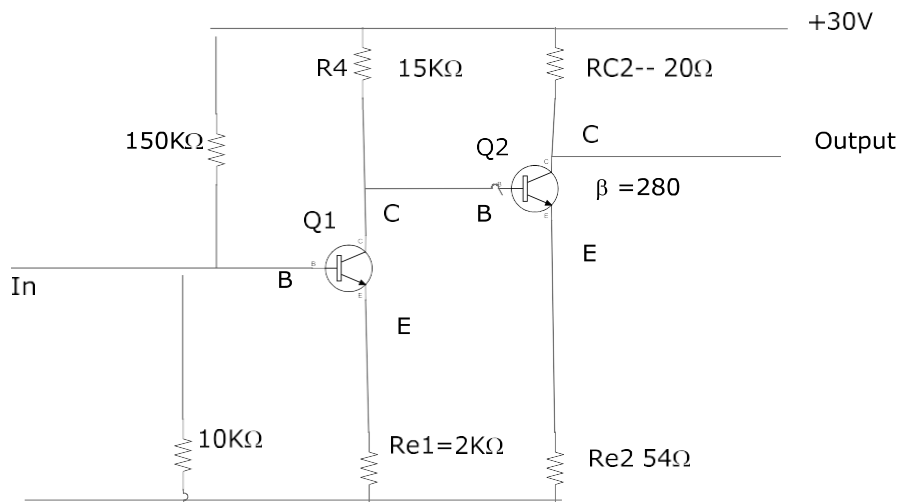

(12) Direct coupled amplifier, differential amplifier

Slide 1+2

Q37. If  $R_{c1} = 3k\Omega$ ,  $R_{c2} = 4k\Omega$ ,  $R_{b1} = 40k\Omega$ ,  $R_{b2} = 35k\Omega$ ,  $R_e = 2.8k\Omega$ ,  $V_{cc} = 15V$ ,  $V_{be} = 0.6V$

Calculate  $V_{b1}$ ,  $V_{b2}$ ,  $V_{e1}$ ,  $V_{e2}$ ,  $I_t$ ,  $I_{c1}$ ,  $I_{c2}$ ,  $V_{c1}$ ,  $V_{c2}$

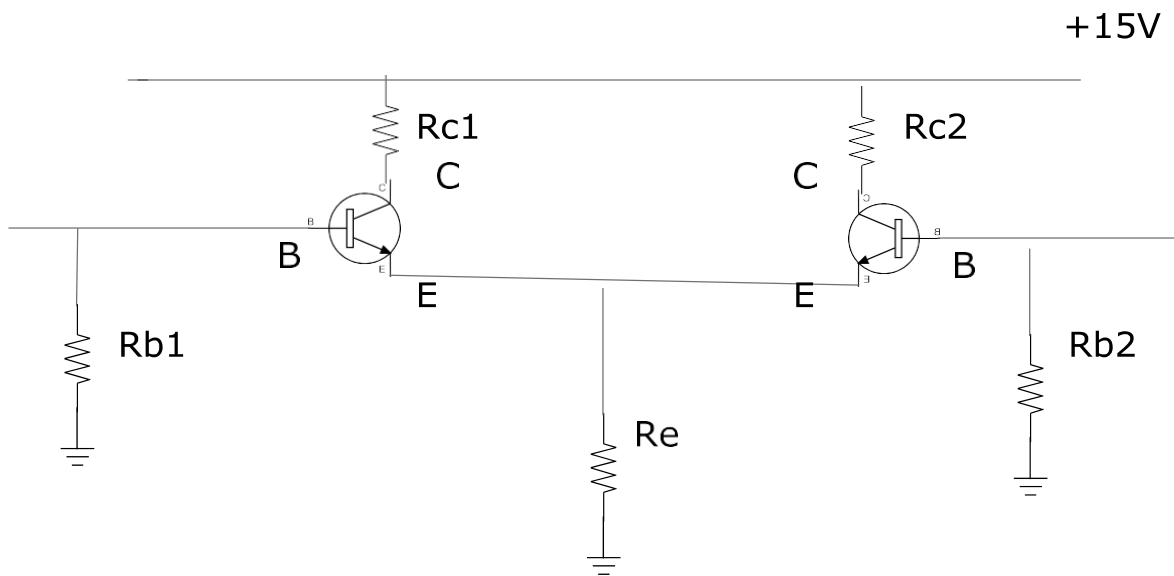

Slide 3

Q38. Sketch discrete differential amplifier with current source.

I006

(1) Process control transducers

Slide 1 to 5

Q1.Explain the principle of analogue signal conditioning with sketches

Q2.How is the signal transmitted?

Slide 5+6+7

Q3.Explain (a) Digital signal storage (b) Control signal (c) Signal conversion (d) Signal transmission

Slide 8

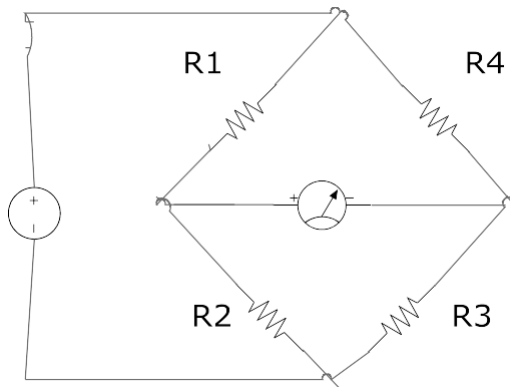
Q4.In given wheat stone bridge if  $R_1=2000\Omega$ ,  $R_2=342\Omega$ ,  $R_3=700\Omega$ . Find  $R_4$ 

Slide 4

Q5.Write the equation for galvanometer detector.

Slide 10

Q6.A bridge circuit has  $R_1=R_2=R_3=3K\Omega$  resistances  $R_4=8K\Omega$ / 5V supply . The bridge is nulled. A galvanometer with  $50\Omega$  internal resistance is used. Find offset current.

Slide 11+12

Q7.Sketch trigger control system.

Slide 13

Q8.Describe the followings (a) Parameter (b) Range (c)Accuracy (d)Linearity(e)Noise

Slide 14+15

Q9.Derive the equation to calculate unknown resistance in AC bridge.

Slide 16

Q10.Explain high pass filter

Slide 17+18



Q11. Pulses for stepping motor are being transmitted at 3000HZ. Design a filter to reduce 60HZ noise but reduce the pulses by no more than 4dB.

Slide 19 to 29

Q12. Do the exercise with PLC TL31 V3 software

---

(2) Operational amplifier

Slide 1+2

Q13. Explain the followings with sketch

- (a) Input offset voltage
- (b) Input offset current
- (c) Input bias current
- (d) Slew rate
- (e) Unity gain frequency gain bandwidth
- (f) Voltage follower
- (g) Summing amplifier

Slide 3

Q14. Develop an op-amp circuit that can provide an output voltage that is related to input voltage by  $V_{out} = 5 V_{in} + 8$

Slide 4

Q15. Design a high impedance amplifier with a voltage gain of 52.

Slide 5+6+7

Q16. A sensor outputs a range 20 to 300mV as a variable varies over its range. Develop signal conditioning so that this becomes 0 to 10V.

Slide 8+9+10

Q17. A sensor outputs 0 to 5V develop a circuit so that this becomes 0 to 20mA. Specify the maximum load if op-amp saturates at 20V.

Slide 10+11

Q18. Use an integrator to produce a linear ramp voltage rising 20V per ms.

Slide 12

Q19. Sketch the linearization circuit.

Q20.Explain logarithmic amplifier circuit.

Slide 13

Q21.Explain SCR

Slide 14+15+16+17+18

Q22.Do the exercises on slides 14+15+16+17+18

Slide 19

Q23.Explain thermocouples with sketches.

-----

(3)Pneumatic

Slide 1+2+3

Q24.What is pneumatics?

Q25.What is pressure?

Slide 4

Q26.In industrial hydraulic lift, if force 2N is applied to piston with  $1\text{m}^2$  CSA to lift 1320Kg, find the diameter of lift.

Slide 5+6+7

Q27.Explain flow & pressure drop

Q28.Explain Boyle's & Charle's combined law.

Slide 8

Q29.Explain the principle of flow through an orific to atmosphere.

Slide 9

Q30.Explain free air & compressed air.

Slide 10+11

Q31.Explain vacuum pressure

Slide 12

Q32.An air reservoir with a volume of  $10\text{m}^3$  must be filled with compressed air to a maximum pressure of 80Kpa ( 8 bar) . Calculate the volume of free air.

Q33.A bath room with a gas volume of  $0.5\text{m}^3$  at a temperature of  $-15^\circ\text{C}$  is heated to a temperature of  $100^\circ\text{C}$  . What is the increased gas volume it pressure remains constant.

-----

(4) Digital control (H012+I006-4 Digital control)

Slide 1+2

Q34. Define the followings

- (a) Analogue (b) Digital (c) CMOS (d) TTL (e) DTL (f) HTL (g) ECL (h) Logic (i) Synchronous logic (j) Asynchronous logic

Slide 3+4+5

Q35. Sketch the following gates, electrical diagram and logic diagram

- (a) AND (b) OR (c) NOT (d) NAND (e) NOR (f) Ex-OR

Slide 6+7+8+9+10

Q36. Explain De Morgan theorem.

Q37. Sketch NAND & NOR equivalent of NOT, AND, OR, NAND & NOR gates.

Slide 11+12+13

Q34. Sketch the circuit & truth tables for (a) Adder (b) Half adder (c) Full adder (d) Cascading circuit

Slide 14 to 19

Q35. Explain encoder & decoder

Slide 20

Q36. Explain thermocouple

Slide 21+22

Q37. Explain (a) Thermistor (b) RTD

---

(5) PLC TL131

Slide 1+2+3+4+5+6

Q38. Do the exercises for slide 1 to 6

Slide 7+8

Q39. Explain temperature measurement.

---

(6) Encoder + Decoder

Slide 1

Q40. Explain (a) Serial data (b) Parallel data (c) ASCII code

Slide 2+3+4

Q41.Explain the operation of multiplexer with sketch

Slide 5+6

Q42.Explain (a) Flip flop (b) NOR gate flip flop (c)NAND gate flip flop (d)RS flip flop

Slide 7+8

Q43.Explain gated SCR latch , clocked RS flip flop & development of flip flop

Slide 9

Q44.Explain J-K flip flop

Slide 10+11+12

Q45.Explain master-slave flip flop

Slide 13+14

Q46.Explain shift registers & data latches

Slide 15+16+17+18

Q47.Explain counters, modulus counter , counter IC

Slide 18+19

Q48.Sketch 7 segment display.

Slide 20

Q49.Sketch 4 bits shift register

Slide 21+22

Q50.Explain counter

-----  
(7)Digital signal processing

Slide 1

Q51.Explain analogue & digital signal

Slide 2

Q52.Find the binary equivalence of  $279_{10}$

Slide 3

Q53.Find binary and decimal equivalence of 358

Slide 4+5+6

Q54.Find decimal equivalence of 57H, 38DH, A3FH

Slide 6+7

Q55. Find hex decimal equivalence of  $30_{10}$ ,  $177_{10}$ ,  $3512_{10}$

Slide 8+9

Q56.  $-1011_2$  Use 2's complement.

Slide 10

Q57. Find the base 10 equivalence of binary number  $0.11011_2$ .

Slide 11+12

Q58. Find binary, octal & number hex decimal equivalence of  $0.4125_{10}$

Slide 13+14

Q59. How will you design the digital gate system to control the process.

Slide 15

Q60. Explain (a) PLC (b) Buffer

Slide 16+17

Q61. A process control system specifies that temperature should never exceed  $170^\circ\text{C}$  if the pressure also exceeds  $15\text{Pa}$ . Design alarm system to detect this condition using temperature & pressure transducer with transfer  $2.5\text{mV}/^\circ\text{C}$  &  $0.3\text{V}/\text{Pa}$  respectively.

Slide 19+20

Q63. A transducer converts the liquid level in a tank to voltage according to transducer function ( $25\text{mV}/\text{cm}$ ). A comparator is supposed to go high (7V) whenever the level becomes  $60\text{cm}$ . Splashing causes the level to fluctuate to protect against the effects of splashing.

-----  
(8) DAC + Flip flop + Sensor

Slide 1+2+3

Q64. What is the output voltage of a 10 bit ADC with a  $20\text{V}$  reference if the input is (a)  $0010111101$   
(b)  $20\text{EH}$

Slide 4

Q65. Calculate  $\Delta V$  out for 10 bit D/A converter with  $15\text{V}$  reference.

Q66. Determine how many bits a D/A converter must have to provide output increment of  $0.05\text{V}$  (or) less. The reference is  $15\text{V}$ .

Slide 5+6

Q67. Explain DAC & ladder network

Slide 7+8

Q68. A control voltage has a linear variation of opening as the input voltage varies from 0 to 15V. A micro computer outputs a 8 bits word to control valve opening using an 8 bits DAC to generate the valve voltage (a) Find the reference voltage requires to obtain a 15V (b) Find the percentage of value opening for 1 bit change in impact word.

Slide 9+10+11

Q69. Temperature is measured by a sensor with an output of  $0.04\text{V}/^\circ\text{C}$ . Determine the required ADC reference and word size to measure 0 to  $150^\circ$  with  $0.1^\circ\text{C}$  resolution.

Q70. Find the digital word that results from a 3.237V input to 5 bit ADC with 10V reference

Slide 12

Q71. The input to a 10 bit ADC with 3V reference is 2.5V what is the hex output supposed the output is found to be 1E5H. What is input voltage?

Slide 13+14

Q72. Reference voltage = 15V, 8 bit. If -7V is represented at all bits zero condition (Ref), determine the one step moment of bit.

Slide 15+16

Q73. What is the hex and binary output of a bipolar 8 bit ADC with 10V reference for input of -0.75V and 1.8V what input voltage would cause 73H?

Q74. Sketch DA converter for subtraction.

---

(9) Analogue to digital conversion

Slide 1+2

Q75. Find the successive approximation ADC output for a 4 bit converter to a 3.317V input if the reference is 10V.

Slide 3

Q76. Explain temperature measurement.

Slide 4+5+6

Q77. Explain the light and light transducer LDR.

Slide 7+8+13

Q78. What is the output voltage of a 10 bit DAC with a 20V reference if the input is (a) 001 0110 111 (b) 30EH. What input is needed for 7.5V output?

Slide 9

Q79. 10 bit D/A converter 15V reference, find  $\Delta V_{\text{out}}$ .

Slide 10+11

Q80. Find the successive approximation ADC output for a 5 bit converter to a 3.275V input if the reference is 15V.

Slide 12

Q81. Explain (a) Ramp A/D (b) Dual slopes A/D

Slide 14

Q82. A dual slopes ADC is shown in figure. It has  $R = 200\text{K}\Omega$   $C = 0.02\mu\text{F}$ . The reference is 15V & the fixed integration time is 15 ms. Find the conversion for 7.5V input.

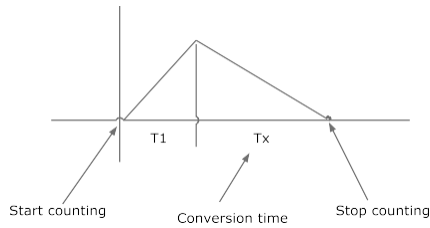

Slide 15

Q83. Explain the followings

(a) Input (b) Output (c) Reference (d) Power supply (e) Digital signal

Slide 16+17+18

Q84. A measurement of temperature using a sensor that outputs  $7.5\text{mV} / ^\circ\text{C}$  must measure to  $150^\circ\text{C}$ . A 6 bit ADC with 15V reference is used. (a) Develop a circuit to interface with the sensor with ADC (b) Find temperature resolution

Slide 19

Q85. Explain microprocessor compatible ADCV with sketch.

Slide 20.

Q86. Explain sample & hold circuit.

Slide 21+22

Q87. Explain data acquisition system and interface.

Slide 23

Q88. Explain ADC, sample hold, hardware programming & software programming.

(10) Temperature control

Slide 1+2+3

Q89. Explain temperature control (Analog control) scheme with sketch.

(11) Industrial transducer

Slide 1+2

Q90.Explain industrial transducer, transducer and sensor.

Slide 3

Q91.Define and explain the followings (a) Range (b) Span (c) Linearity (d) Sensitivity (e) Resolution (f) Temperature measurement (g) Force measurement (h) Speed measurement (i) Encoder (j) Position measurement (k) Synchros

Slide 4

Q92.Explain force measurement

Slide 5

Q93.Explain speed and position measurement

Slide 6+7+8+9

Q94.Explain final control element, relay and contactors , types of relay, valve, input converter, hydraulic valve.

Slide 10+11+12

Q95.Explain solid state control system.

Q96.Explain automatic control system

Slide 13.

Q97.Explain (a) Open loop control (b) Water tank (c) DC motor speed control (d) Automatic motor starter (Time limit)

Slide 14

Q98.Explain (a) Closed loop control (b) Automatic motor starter current limit (c)DC motor speed control

Slide 15

Q99.What are the requirements of closed control system?

Slide 16+17+18+19+20

Q100.Do the exercises for review questions in slide 16+17+18+19+20

---

(12)Control system evaluation

Slide 1

Q101.What are to be taken account into evaluation of control system.



Slide 2

Q102. Sketch the diagram for process log.

Slide 3+4+5

Q103. Explain process capacity & resistance, damping and instability, two positions control, level control, process control (proportional control).

Slide 6

Q104. If  $PB = 66.67\%$ ,  $200\%$  calculate gain . If gain = 2 calculate PB

If Gain = 0.8 calculate PB

Slide 7+8

Q105. Explain proportional +integral control

Slide 9+13

Q106. Explain proportional +Derivative control.

Slide 10

Q107. Explain proportional +Integral + Derivative control (PID)

Slide 11+12

Q108. Explain (a) Open loop control (b) Closed loop control with sketches

Slide 14+15

Q109. Explain control loop conditioning

Slide 16.

Q110. Sketch a diagram which included both batch control and continuous control

Slide 17+18

Q111. Do the exercise on slide 17

Slide 19

Q112. Explain (a) Batch process (b) Sketch a basic diagram representing a typical batch process system & briefly outline it's operation.

---

(13) Proportional control

Slide 1+2

Q113. Explain proportional control

Q114. Explain integral control

Slide 3+4

Q115.Explain proportional + integral control

Slide 5+6+7

Q116.Explain proportional +Derivative (PID)control

Slide 8

Q117.Explain analogue control with circuit & block diagram.

Slide 9

Q118.Explain digital control

Slide 10

Q119.Explain final control elements

Slide 11+12+13+14+15

Q120.Do the exercises in slide 11+12+13+14+15

---

(14) Electronic Signal System

Slide 1

Q121.Sketch the overview of electronic signal and systems in process control

Slide 2

Q122.Sketch power distribution system

Slide 3

Q123.Explain position control system.

Slide 4+5

Q124.Explain time & frequency domain

Slide 6

Q125.What is the fundamental of Fourier analysis?

Slide 7

Q126.A waveform has a period  $T = 50\text{ms}$ , calculate the frequency of the fundamental, the second , third and fourth harmonics.

Slide 8

Q127.Indicate pulse energy on diagram.

Slide 9

Q128.What is harmonic distortion?

Slide 10+11

Q129.What is filter?

Q130.Explain analogue and digital signals.

Slide 12+13

Q131.Explain pulse code modulation (PCM) and PCM coding process.

Q132.What is low pass filtering and sampling?

Slide 14

Q133.Explain time domain multiplexing with diagram

Slide 15

Q134.Explain industrial transducers with diagram.

Slide 16

Q135.Explain (a) temperature measurement (b) thermistor

Slide 17

Q136.Explain force measurement.

Slide 18

Q137.Explain speed measurement

-----  
(15) Types of transducers

Slide 1+2+3

Q138.Explain linear variable differential transducer with sketch and it's applications.

Slide 3+4

Q139.Explain position measurement

Slide 5+6+7+8

Q140.Explain electric field sensor, inductive sensor, sensing device, capacitance proximity sensor.

Slide 9

Q141.Explain ultra sonic sensor

Slide 10+11

Q142.Explain hall effect switch and application

Slide 12

Q143.Explain the method of tuning P and D controller using the systematic trial method.

Slide 13

Q144.Explain the tuning of PID controller

Slide 14

Q145.Do the exercises in slide 14

Slide 15

Q146.Explain the procedure involved in tuning a controller using the ultimate cycling method.

Slide 16+17

Q147.Do the exercise in slide 16.

Slide 18+19

Q148.Sketch the graph showing QAD and minimum disturbance response

Q149.Explain the procedure required to tune a controller using the open loop (step response) method.

-----  
(16) Speed measurement

Slide 1+2

Q150.Explain speed measurement and analogue tacho-meter.

Slide 2+3

Q151.A tacho generator has an output voltage of 3V/ 1000 rpm. If it's output voltage is 3.5V when connected to a motor shaft , determine the motor shaft speed.

Q152.Explain digital tacho meter

Q153.Explain position measurement by precision potentiometer.

Slide 4+5

Q154.Explain synchro, shaft angle encoder.

Slide 6

Q155.Sketch position transducer & explain it's applications

Slide 7+8+9

Q156.Explain force measurement by strain gauge.

Slide 10

Q157.What is gauge factor of strain gauge?

Slide 11

Q158.Sketch piezo electric device

Slide 12+13+14+15+16

Q159.Do the exercises in slides 12+13+14+15+16

K025

(6) Solar module energy output

Slide 1+2

Q16.Explain (a) Characteristics of sunlight (b) black body (c)emergy density of black body radiation distribution of sunlight

Slide 3+4

Q17.Describe solar insolation measurement

Q18.Explain estimation of global radiation.

---

(7) Solar geometry

Slide 1+2

Q19.Explain solar geometry

---

(8) Altitude and Azimuth angles

Slide 1+2+3+4

Q20.Explain altitudes and azimuth angles

Q21.Write the formula to calculate standard solar time.

Slide 4

Q22.What are the properties of semiconductor.

---

(9) Free electron + Energy from sun

Slide 1+2

Q23.Sketch the atomic structure of photovoltaic material & explain the construction & operation.

---

(10) Fermi level

Slide 1

Q24.What is fermi level?

Slide 2 to 6

Q25.Explain fermi conductor.

Slide 7

Q26.Explain poly crystalline silicon

Slide 8

Q27.Write the process to manufacture solar module.

---

(11) Light fall on solar cell.

Slide 1+2

Q28.What are the types of stresses on solar modules?

Slide 3+4+5

Study the solar software applications.

---

(12)Production +current equation of solar cells.

Slide 1+2+3+4

Q29.Explain solar cell semi conductor dark and illuminated current

Slide 5+6

Q30.What are the output parameters of solar cell?

Slide 7+8+9+10

Q31.What are the production steps of solar cells?

Slide 11

Q32.Write the equation for the cost of electricity by using solar cell.

Slide 12

Q33.What is optical loss?

---

(13) Solar radiation & shading assessment

Slide 1

Q34.Write the equation to calculate dark cell current.

Slide 2

Q35.Write the equation to calculate solar cell current.

Slide 3

Q36.Write the equation for maximum power output related to series resistance.

---

(14) Irradiation calculation

Slide 1 to 5

Q37.Explain solar radiation and shading assessment procedures.

Slide 6+7

Q38.Do the exercises for the problems in slide 6

-----

(15) Exciting of free electron by sunlight

Slide 1+2+3+4

Q39.Explain (a) Recombining process (b) Radiative recombination (c)Auger recombination (d)Recombination through traps (e)Recombination at surface (f)electronic matching.

Slide 4+5+6

Q40.Sketch PV system configuration circuits.

Q41.PV only system using integrated charge regulator, load controller

Slide 6+7

Q42.Sketch & explain dc PV system with backup generator set (Gen set)

-----

(16) Solar irradiation

Slide 1+2+3

Q43.Calculate monthly average total irradiation on horizontal surface for 18 January in Brisbane

Date

A= 0.42 B =0.22

----

$n = 7.5$  , Latitude angle of Brisbane =  $-27.5^\circ$   $\phi = -27.5$

Declination angle of sun =  $-20.9$ ,  $\delta = -20.9^\circ$

Slide 4+5+6+7

Q44.Explain (a) Hot spot heating (b) Efficiency limit losses & measurement

Q45.Explain PV cell interconnection & module fabrication.

Slide 8+9+10

Q46.What is efficiency limit for black body cell?

Q47.What is the effect of temperature?



Q48.Explain the interaction of light with semi conductor.

---

(17) Battery charger system

Slide 49.What are the components of PV electrical system?

---

(18) Configuration of solar system

Slide 1 to 6

Q50.Sketch PV water pumping system & explain components.

Slide 7+8

Q51.Exelectrical system plain power conditioning circuitry of solar water pump.

---

(19) PV water pumping

Slide 1+2+3

Q52.Write the equations for PV water pumping.

Slide 4 to 8

Q53.Sketch (a) Series system for PV electrical system (b)switched system (c)grid interactive system.

Slide 9

Q54.What are the requirement of AS 4509?

Slide 10

Q55.Sketch PV lighting system

(20) Array efficiency+ system design

Slide 1+2+3+4

Q56.Latitude 30°N Reference temperature = 25°C, typical ambient temperature 8°C, array operates at 25°C, above ambient temperature

Daily irradiation = 6000Kwh POA = 5Kwh / m<sup>2</sup> SD = 1.  $n_{MPPPT} = 90\%$   $n_{battery} = 90\%$  DF= 0.95 Ci 0.005  
Tr= 25°C, calculate total area of solar panels.

Slide 5+6+7

Q57.Explain PV water system for water pumping.

Slide 8 to 13

Q58.What are typical characteristics of PV module?

Slide 14 to 17

Q59. Do the exercises for slide 14

Slide 18+19+20

Q60. Do the exercises for slide 18.

---

(21) Solar water pump calculation

Slide 1

Q61. Calculate solar power arriving on 20 sqm of roof area if irradiance perpendicular to the roof is  $2000 \text{ W/m}^2$

Slide 2

Q62. Calculate the daily solar energy received by a standard hot water collector of dimension 2m x 3m in location of  $30 \text{ MJ/m}^2$  day

Q63. Calculate the solar energy received by a standard hot water collector of dimension 2m by 4m over one hour around noon. If irradiance stays fairly constant at about  $1000 \text{ W/m}^2$

Slide 3 to 8

Q64. Suction head = 3 delivery head = 10, friction suction = 0.25, delivery = 5 Required back pressure = 1.6

Calculate (a) total head (b) NPSHA by using data table

Slide 9+10+11

Q65. Write equation for overall efficiency of solar water system

K035

(1) Inverter introduction

Slide 1

Q1. Sketch the waveforms for (a) DC to pulsating AC inverter (b) Modified sine wave , step sine wave inverter (c) PWM inverter.

Slide 2

Q2. Sketch the block diagram for stand alone PV system.

Slide 3+4

Q3. What is inverter?

Slide 5

Q4. What is grid tie inverter?

Slide 6

Q5. What are the applications of inverter?

-----

(2) Inverter

Slide 1+2

Q6. Sketch basic inverter principle circuit and operating principle.

Slide 3

Q7. Sketch (a) H bridge inverter (b) Three phase inverter

Slide 4+5

Q8. Explain PWM technology and inverter circuit used with PWM technology.

Slide 6

Q9. Explain modified sine wave inverter.

Slide 7 to 10

Q10. Explain the oscillator for inverter circuit.

Slide 8+9=10+11

Q11. A crystal oscillator has the following parameters  $C_p = 50\text{PF}$   $C_o = 10\text{PF}$   $R = 100\Omega$  at  $10\text{MHZ}$  for a CMOS inverter with an open loop gain  $a = 200$  calculate the value of feedback resistor.

Slide 12+13+14

Q12. Explain the operational requirement of crystal oscillator for inverter

Slide 15+16

Q13.Explain the basic principle of sine wave inverter.

---

(3) Sine wave inverter

Slide 1

Q14.Sketch the graphs for square wave , modified sine wave & pure sine wave.

Slide 2+3

Q15.Explain pulse width modulation.

Slide 4+5

Q16.Explain the operation of Bubba oscillator.

Slide 6

Q17.Sketch H bridge construction & operation table.

Slide 7

Q18.Explain MOSFET driver with sketch.

Slide 8

Q19.Explain inverter circuit protection and snubber.

---

(4) PWM

Slide 1

Q20.Explain PWM with sketch.

Slide 2

Q21.Explain active filter and passive filter.

Slide 3+4+5+9

Q22.Sketch the example diagram of pure sine wave inverter and explain it's operation.

Slide 2+3+4+5+6

Q25.Explain filter design.

Slide 7+8+9+10

Q26.Sketch pure sine wave inverter circuit and explain the operation.

Slide 11+12

Q27.Sketch overview of grid connected inverter system and explain it's operation.

Slide 13+14+15

Q28. Sketch grid connected PV system with multiple inverter.

Slide 16

Q29. Explain the energy saving aspects of solar electrical system.

---

(6) Switching mode + Photovoltaic inverter

Slide 1+2

Q30. Explain PV inverter system with sketch.

Slide 3+4+5

Q31. What are the causes of frequency distortion to PV inverter?

Slide 6+7

Q32. Write the equation for switching delay.

Slide 8+9

Q33. Sketch inverter output current diagrams & total harmonic distortion for unipolar switching & bipolar switching.

---

(7) Grid connected inverter system

Slide 1

Q34. What are the topologies of grid connected inverter?

Slide 2

Q35. Sketch transformerless PV inverter system

Slide 3+4+5

Q36. Sketch PV inverter with frequency transformer .

Slide 6

Q37. Sketch PV inverter with several conversion stage & high frequency transformer.

Slide 7

Q38. Sketch PV inverter with several conversion stages including boost stage

Slide 8

Q39. Explain the configuration and standards for grid connected PV system with diagram.

Slide 9

Q40. Sketch and explain the operation of wind turbine grid connected system.

Slide 10

Q41. Write the standard testing procedures for grid connected inverter.

Slide 11+12

Q42. Explain (a) MPPT (b) voltage rating & protection of solar panel (c) Sketch typical solar panel PV curve.

Slide 13

Q43. Sketch multi string PV inverter system.

Slide 14+15

Q44. Explain grid connected PV system control system with sketch.

Q45. Write the mathematical modelling for switched mode inverter.

Slide 16

Q46. Express the parameters of grid connected power inverter.

Slide 17+18

Q47. Do the exercises in slide 17+18

K041+E047

(1) Passive solar design

Q1.What is a active solar system?

Q2.What are micro-climates in Australia?

Slide 2+8

Q3.What is passive solar system design?

Slide 3

Q4.What is thermal mass?

Q5.What are the features of hot humid climate?

Slide 4

Q6.Sketch the building glassing system & how it effects the heating in building?

Slide 5

Q7.Sketch the overview & layout of a building for wind and direct entry

Q8.Sketch direct and indirect sun gain system

Slide 6

Q9.Sketch solar collector.

Slide 7

Q10.Sketch (a) Air based solar system (b) Water based solar system.

Slide 9+10+11

Q11.What are the factors affecting comfort?

Slide 12+13+14

Q12.Explain psychometric chart.

Slide 15

Q13.Explain (a) Humidity (b) Relative humidity (c) wet bulb temperature (d) Dew point temperature

Slide 16+17

Q14.Sketch the construction of air conditioning system for commercial building

Slide 18+20

Q15.Explain the methods for measuring air movement and balancing

Slide 19

Q16.Describe basic building construction with sketches.

(2) climate and human comfort

Slide 1

Q17.What is comfort?

Slide 2

Q18.Write the equation to calculate heating degree day.

Q19.Sketch wind and flow diagram of world

Slide 3+4

Q20.Describe the feature of (a) Hot arid zone (b) Temperate zone

Slide 5+6

Q21.How does heat produced in human's body?

Slide 7+8

Q22.What change is required to make the comfort when relative humidity is too high?

Slide 9

Q23.What is shading coefficient?

Slide 10+11

Q24.Sketch incidence & reflected ray diagram.

Slide 11

Q25.Write the equation for environmental temperature & dry resultant temperature.

Slide 12+13

Q26.Write the equation for thermal neutrality.

Slide 14.

Q27.Write the heat gain values for various types of activities.

Slide 15+16

Q28.Do the activities in slide 15+16

Slide 17+18+19+20

Q29.Explain heat pump.

Slide 20+21

Q30.Sketch liquid flow piping and wiring diagram for heat pump.

Slide 22



Q31.Explain solar heat and specific heating system

Slide 23+24+25+28+29

Q32.Sketch building footing system.

Slide 26.

Q33.Sketch roof and ceiling construction

Slide 27

Q34.Write the types of constructions, summer, winter heat flow and appropriate insulation size of various roof constructions.

---

(3) Solar calculation , thermodynamic principle

Slide 1

Q35.Sketch solar irradiation diagram

Slide 2

Q36.Write the equation to calculate solar irradiation.

Slide 3

Q37.Explain (a) Thermodynamic principle & heat flow (b) First law of thermodynamic (c) Second law of thermodynamic

Slide 4+5+6

Q38.A mud brick wall has the following dimensions (Height = 3 m length = 4m Thickness = 500 mm If two walls surfaces are 20°C and 12°C respectively, calculate (a) The rate of heat flow through the wall (b) R value of wall.

Slide 7+8+9

Q39.Explain (a) Convection (b) radiation (c) Emissive power (d) Emittance (e) Surface conductance.

Slide 10+11+12+13+14

Q40.Do the exercises for problem in slide 10

Slide 15+16+17+18+19

Q41.Do the exercises for problems in slide 15.

Slide 20+21+22+23

Q42.Do the exercises for problems in slide 20.

---

(4) Windows & shading

Slide 1

Q43. What are the purpose of windows?

Q44. What is solar heat?

Slide 2+3+4

Q45. Write the methods to reduce summer heat gain through windows.

Slide 5

Q46. Explain types of glazing system

Slide 6

Q47. What are the ways to maximize sun light. Sketch them.

Slide 7

Q48. Sketch energy balance diagram of standard 3mm clear glass.

Slide 8+9

Q49. Explain hydrosonic emitting equipment.

Slide 10

Q50. Sketch windows heat gain and loss diagram

Slide 11+12

Q51. Calculate the net heat gain or loss of heat through a north facing single glazed window for July . In Sydney, the window is 1 m high & 0.3 m wide. The bottom of the eaves which are 0.7 m wide. Assume for the window that 80% of it is glass. The transmittance is 0.8 and U value is 7.

For July , daily irradiation =  $9 \text{ MJ/ d- m}^2$  Vertical wall facing north =  $H_v = 13 \text{ MJ/ d- m}^2$  Vertical If the wall is shaded  $H_{vs} = 1413 \text{ MJ/ d- m}^2$  Maximum temperature for July =  $17^\circ\text{C}$  Minimum temperature for July =  $6^\circ\text{C}$ .

Slide 13+14+15

Q52. Write the equation for shading & sketch diagram.

Slide 16

Q53. Do the exercise in slide 16

Slide 17+18+19+20+21+22

Q54. Do the exercise in slide 17.

Slide 23

Q55. Do the exercise for problem in slide 23.

---

(5) Insulation, Australian standard for energy efficient building design

Slide 1

Q56.Explain insulation

Slide 2+3

Q57.Explain (a) Radiation (b) Convection (c) Types of insulation (d) Bulk insulation

Slide 4+5+6

Q58.Explain the methods to install insulation

Slide 7

Q59.Express the relevant Australian standards for insulation.

Slide 8+9

Q60.Explain (a) thermal mass & storage (b) sensible heat (c) latent heat

Slide 10

Q61.Sketch the graph for properties of thermal mass

Slide 11

Q62.What is thermal admittance?

Slide 12

Q63.What is response factor?

Slide 13+14

Q64.Explain heat storage in proactive with diagram.

Slide 15

Q65.Sketch the construction of wall.

Slide 16+17+18+19

Q66.Do the exercise for the problems in slide 16.

Slide 20+21+22+23+24

Q67.Do the exercise for problem in slide 20.

---

(6) Ventilation, application of psychrometric chart

Slide 1

Q62.Explain ventilation

Slide 2+3+4+5+6

Q63. Describe air velocity and air volume

Q64. What are the systems of ventilation? sketch the diagrams.

Slide 7+8

Q65. Sketch air ventilation system for multi storey building.

Slide 9

Q66. Describe the application of psychrometric chart.

Slide 10+11+13+14

Q67. In winter, air at dry bulb temperature of  $66^{\circ}\text{C}$  & 70% RH enters the building through a heating battery. It is heated to dry bulb temperature of  $25^{\circ}\text{C}$  without adding moisture from psychrometric chart. Find

- (a) Wet bulb temperature of incoming air
- (b) Relative humidity of heated air.

Q68. In Summer, air at dry bulb temperature of  $27^{\circ}\text{C}$  and wet bulb temperature  $20^{\circ}\text{C}$  enters the building through a cooling coil. It is cooled to dry bulb temperature of  $19^{\circ}\text{C}$

Find

- (a) Relative humidity of incoming air
- (b) Relative humidity of supply air after cooling.

Q69. The air in a room has a dry bulb temperature of  $23^{\circ}\text{C}$ . Find (a) The relative humidity of air (b) The temperature of walls when condensation occurs.

Q70. Air enters the plant at a dry bulb temperature of  $24^{\circ}\text{C}$  and 80% RH & is required to be cooled to dry bulb temperature of  $19^{\circ}\text{C}$  & 60% RH. Find (a) the temperature of air in washer (b) the reduction in moisture content of supply air.

Slide 16+17+18+19+20

Q71. (a) Calculate heat gain per day from the customers in a  $200\text{ m}^2$  gym, If the gym capacity is 60 customers and the gym is full between 6 am to 8 am and 5 pm to 8:30 pm. At all other times, it is 30% full on average.

(b) Calculate heating contributions from all the appliances in a communal house containing 8 people. The house has one electric hot water system for two bath rooms, 6 bed rooms and one all electric kitchen. One TV, seven music systems, two computers and twenty lights. Assume that the house uses 32 kWh per day and the hot water is 45% of the load. The cooker consumes 20% of the load and 20% of heat generated by cooker is vented outside by the range hood.

(c) In above (b) would it make any difference if the water heater was located outside the building?

(d) What would be the heat gain per month if the cooker in (b) uses bottle gas (Gas is  $45\text{ MJ/Kg}$  and the house uses  $0.5\text{ kg/day}$ )?

(e) The table below lists the power consumption of the appliances used in the house and the hours per day for which they are used. Calculate heat gain from appliances per month.

Appliance	Power (watt)	Daily usage per appliance (hr)
TV	50	15
Music system	45	3
Computer	100	13
Printer	20	1
Lights	80	2

(7) Thermal mass, centralised air conditioner, cooling load

Slide 1

Q72. What are the materials that can be used as thermal mass. Explain the installation method of them.

Slide 2+3+4

Q73. Sketch the concrete slab on ground for stable soil.

Slide 5+6

Q74. Do the activity in slide 5

Slide 7+8

Q75. Explain centralised self contained air-conditioning system.

Slide 9+10

Q76. Sketch & explain the induction convective air conditioning system.

Slide 11

Q77. Calculate the COP of a heat pump when condenser and evaporator temperature are 50°C and 3°C respectively. Assuming 95% efficiency

Slide 12

Q78. Explain the function of humidifier

Slide 13+14+15+16+17+18+19+20+21+22+23

Q79. Do the exercises for the house shown in slide 1<sup>^</sup>=17

-----

(8) Ventilation

Slide 1+2

Q80. A 5000 sq ft retail store near Tucson Arizona has been calculated to have sensible heat gain of 200,000 BTU at summer design condition (110DB, 70WB) for this location. Calculate the heat removed and air flow rate in door to reduce 8°F temperature.

Slide 2 to 6

Q81. Do the exercise for problems in slide 2 & 3.

---

(9) Electrical load calculation.

Q82. All electrical appliances in a house uses 30 kwh per day and the hot water is 35% of the load. The cooker consumes 15% of the load and 30% of heat generated by cooker is vented outside by the range hood. Find the heating effect of appliances per month.

Slide 2+3+4+5

Q83. Describe heat gain calculation method.

---

(10) Building service energy management

Slide 1

Q84. Explain building service energy management system.

Slide 2

Q85. Write electricity & oil gas energy unit calculation formula

Slide 3+4

Q86. Compare building load sources

Q87. Express factors influencing room load.

Q88. What are fresh air requirements for various types working spaces.

Slide 5

Q89. Sketch fresh air supply system.

Slide 6

Q90. What are the factors affecting building energy

Slide 7 to 15

Q91. Sketch building water supply system and pipe fitting

Slide 10+11

Q92.Sketch hot water system.

---

(11) Design for climate

Slide 1 to 4

Q93.What are the principles of design for climate?

Slide 5+6

Q94.Explain how to achieve thermal comfort inside building.

---

(12) Air movement

Slide 1

Q95.Explain air movement to get comfort.

Slide 2

Q96.What is evaporative cooling?

Slide 3

Q97.What are the ways of designing the building for Australian climate?

---

(13) Solar effect & wind condition.

Slide 1

Q98.Explain the features of temperate climate & typical home construction method.

Slide 2

Q99.Explain hot arid climate & home construction method.

Slide 3

Q100.Explain hot humid climate & home construction method.

Slide 4

Q101.Sketch diagram for home to access the wind.

Slide 5

Q102.Write the equation to calculate ventilation.

---

(14) HVAC

Slide 1

Q103.What are the housekeeping check lists for HVAC system?

Slide 2+3

Q104.Explain the energy efficient operation of air-conditioning system.

Slide 4 to 8

Q105.Execute the building survey activities as described in slide 4+5

Q106.What are the building survey procedures for domestic and commercial buildings?

---

(15) Solar hot water system

Slide 1+2

Q107.Sketch solar hot water system.

Slide 3

Q108.Sketch the construction and connection of solar absorber plates

Slide 4

Q109.Describe (a) Collector surface coating (b) Heat transfer medium (c) Insulation (d) Capacity of storage tank (e) Hot water temperature of solar hot water system.

Slide 5

Q110.Sketch connection of collector and storage tank.

Slide 6

Q111.Sketch the hydraulic circuit of solar water.

Slide 7

Q112.Sketch the electrical circuit for solar water heating system.

Slide 8+9

Q113.Describe installation , orientation & sizing of solar collector system.

Slide 10

Q114.Sketch solar assisted heat pump.

Slide 11

Q115.Explain lighting management for commercial building

---

(16) Lighting problems



Slide 1+2

Q116.Explain (a) Glare control (b) Lighting level (c) Lighting efficiency (d) Increase utilization of light.

Slide 3

Q117.Compare dark surface and white surface for illumination

Slide 4

Q118.How can best achieve the energy saving?

Slide 5

Q119.What are the illumination requirements for various places?

---

(17) Fire protection , smoke alarm

Slide 1+2

Q120.Sketch ionisation alarm & explain it.

Slide 32

Q121.Sketch photo electric smoke alarm.

Slide 4+5

Q122.Describe the selection of smoke alarm.

Slide 6

Q123.Sketch the wiring connection for smoke alarm.

Slide 7+8+9

Q124.Indicate the location of smoke alarm in a building.

Slide 10+11+12

Q125.Describe hazardous areas & types of explosion protections.

Slide 13

Q126.What wiring systems & equipments are not allowed in hazardous area?

---

(18) Energy management –human factor

Slide 1+2+3

Q127.Explain motivation for energy management

---

(19) Energy saving campaign

Slide 1+2

Q128.Explain the steps in energy saving campaign.

---

(20) Hot water transmission

Slide 1+2

Q129.Sketch hot water heating design of (a) series loop system (b) two pipes system

Slide 3

Q130.Explain space heating radiant panel.

Slide 4+5

Q131.Explain boiler and system control with sketch.

Slide 6+7+11

Q132.Sketch hot water heating devices.

Slide 8

Q133.Describe the overview of electrical system and design.

Slide 9+10

Q134.Sketch service wire entrance.

---

(21) Motivation for energy saving

Slide 1+2

Q135.Write the check list for motivation for energy saving.

Slide 3+4

Q136.Express activity checklist for energy saving motivation.

Slide 4+5

Q137.Provide the overview of energy management system.

## **Work performance practical and project**

### **Unit**

The practical and projects belong to the units that cover the following study areas

- Study area (1)Power System
- Study area (2)Electrical Machines Drive System + Magnetics
- Study area (3)Power Electronics
- Study area (4)Process Control
- Study area(5)Renewable Energy
- Study area(6)Electrical Fundamental
- Study area(7)Electrical Trade Study

---

### **PART (1) OVERVIEW OF PRACTICAL ASSIGNMENT AND PROJECT TASK**

#### **Project Objective**

The project involves the practical investigation and performance tasks on integrated activities of power system operation , power system protection , transmission line , electrical distribution, electrical machine, drive system, power electronics and electrical fundamental.

By performing some key aspects of simulated task on power system, the students will get the good background and foundation for advanced power engineering study.

#### **Project structure**

The project contains the following parts.

- For practical project, the students need to perform all steps
- For practical assignment, They will need to do (b)Method analysis (Practical task), (c)Analysis of devices (d)Result submission & (f)OHS aspects

#### **(a) Literature study**

The students will need to collect the relevant background theories for the practical tasks outlined in the project. Research, fact finding, problem solving , organizing and presentation skills are to be developed as required by AQF 6 level.

#### **(b) Method analysis (Practical task)**

The practical tasks are designed by using real equipment & by using the images of the real equipment. By using simulated equipments, the students will need to take own practices as much as they like in the mean time, the risk of electrical danger and equipments damage can be reduced.

The students will then need to find the way to do the practical task. The need to connect the equipments either using real physical equipments or online simulated images of real equipments. The correctness of connections are to be checked physically or in diagrams are prepared by using the images of the real equipments.

- If the equipments are energized, the practical test is performed and data are recorded.
- If the equipments are not energized, the rating of the equipments are to be investigated in relevant photographs and the possibility of any overload, mismatch, damage and any danger will need to be concerned and present any thinking.

The photograph for the connection of equipments are to be pasted into project report.

### **(c) Analysis of devices**

The students will need to perform the internet research on the equipments used in practical with real equipments or paper based practical with the image of the equipments utilized in practical.

They will then need to provide the notes on the devices used in the practical

### **(d) Result submission**

- If the practical is performed by using the real equipments, the results obtained in the practical is to be submitted. Tables, graph and circuit diagrams are to be drawn together with conclusion
- If the practical is done by using the images on paper, the possibility of any overload, mismatch, damage and any danger will need to be concerned and present any thinking. If there is no overload, mismatch and possibility of successful operation, as such needs to be confirmed by writing. The circuit diagram is to be drawn & presented.

### **(e) References**

Together with the report, the students will need to provide any references of theoretical and literature review and method analysis.

### **(f) OHS**

The students will also need to provide any OHS aspects and risk minimizing and testing of apparatus used in the project.

## **PART (2) EQUIPMENTS ARRANGEMENTS**

### **Practical Equipments**

The following link contains the picture of equipments used in all practical

<http://uploading.com/files/23628a98/Practical%2BEquipments.zip/>

**Names of practical equipments**

<b>Page Number</b>	<b>Name of equipments</b>
1	DC Power supply
2	Digital multimeter
3	AC 12V Power supply
4	Oscilloscope
6	Isolation transformer
7	Function generator
8	Regulated DC power supply
9,10	Three phase 41.5/ 24V panel
11,12	Varic
13	Power oscilloscope (Power scope)
14	Oscilloscope
15	Function generator
16	DC power supply 0 to 30V
17	Variable resistor set
18	Resistor set
19, 20,21	Rheostat
23 to 27	Variable resistor
28,29	Variable resistor
30,31,32	Resistor panel (parallel)
33,34	Series resistor
35,36	Transformer panel
37,38	Decade resistor box
39	Decade inductor box
40	Resistor
42	Rectifier diode
43	Phase sequence meter
44	Variable resistor
45 , 46	Transformer 200/ 16V
47,48	Coil
49	Underground cable
50,51	Load resistor
52	Decade inductor
53,54	Connection panel
55,56,58	Over current relay
57	Varic
59	Voltage regulator
<b>Page Number</b>	<b>Name of equipments</b>
60	Ammeter
61	Voltmeter
63	Three phase transformer
64,65	Mutual inductance
66,67	Generator model (hand set)
68,69	Main switch
70	Multimeter
71, 72,73,74,75	Current transformer
76,77	DC ammeter
78	Resistor plug

79	Vaccum tube
80	Single phase motor
81,82,83,84,85,86,87,88,89,90	Silicon Controlled Rectifier (SCR) (Thyristor)
91,92,93	Power diode
94,95,96,97,98,99,100	Power diode
101,102	AC circuit
103,104,105	Knife switch
106,107	Resistor
108	Transformer
109	Series resistor
110,111,112,113,114,115,116	Wattmeter
117,118,119,120	Wheatstone bridge
121,122,123	Function generator (Feedback)
124,125	Multimeter
126,127,128,129	Current probe
130,131,132	Power analyzer
133	Connection (Glass panel)
134	SCR power control device
135,142	UJT relaxation oscillator
136	Current boosted 7812 regulator
137	Three terminals regulator LM 317T
138	Test lamp
139	Power control device
140,144	Zero voltage switching
141	Three terminals regulator
143,148	Transistor biasing
145	Power supply principle
146	Trigger pulse generator, Main synchronizing unit
147	SCR
149	Operational unit
150	AC compensation unit
151	Modulator/Demodulator unit
152	Half wave controller
153	Operation unit
154	AC compensation unit
155, 156	Power supply
<b>Page Number</b>	<b>Name of equipments</b>
157	Switches
158	Lamp load
159	Capacitor, resistor, diode
160,161	Capacitor
162	Lamp
163	Panel connection
164	Tee, Pi line Resistor, Capacitor
165	Resistor 0.01 $\Omega$ , 100 $\Omega$ , 5000 $\Omega$
166	Resistor 1 $\Omega$
167,166,169	Hand generator
170,171,172,173,174,175	Combination instrument
176	Electronic test board plug
177	Operational amplifier
178	Choke
179	Cross over board

179	IC socket
180	Operational amplifier
181	Choke coil
182	Resistor 1 $\Omega$
183	Connector neutral/ earth
184,185,186,187,188	Synchronous AC motor
189, 190,191,192	Mini lab
193,194	Coil
195	DC motor
196,197,198,199	Coil
200 to 221	Light meter
222	DIAC/Triac
224,225,226	SCR
227	Syn
228	SCR
229	Precision 1/2 wave rectifier
230	Synchronisation
231	SCR
232	DIAC, TRIAC
233 to 237	SCR
238,238,240	VF Drive
241 to 250	41.5V Three phase motor
251,252	390 $\Omega$ resistor
253	560 $\Omega$ resistor
254	Lamp
255	Resistor panel
256	Voltmeter
257	Ammeter
258	Ammeter (mA)
259	Ammeter
260	Regulated power supply
<b>Page Number</b>	<b>Name of equipments</b>
261	Dual function generator
262, 263,264	30V dc supply
265	Isolation transformer
266,267,268	Capacitor
269	Variable resistor
270,271,273,274	240/24V single phase transformer
275,276,277	41.5/24V transformer
278 to 283	Coil
284	Underground cable
285 ,286,287,288	Line insulator
289,290,291	Pin insulator
292,293,294	AC to DC rectifier, bridge supply
295 to 305	Digital trainer
306 to 312	Communication trainer
313	Fault finding set
314	Oscilloscope probe
315,316	Connector
317	Ammeter
318 to 327	Current transformer
328 to 334	Over current relay

335 to 340	Electronic relay
341	Grip
The rest	K 2.11 Power panels

### **Practical Equipments for online lab**

The following link contains the images of equipments that can be copied into word file, minimize the size and use Insert, Shape Lines command to do circuit connection. They can be printed out, cut , paste on the worksheet and manually draw the connection diagrams

<http://uploading.com/files/m7m1993d/Practical%2BEquipments%2Bfor%2BOnline%2Blab.pdf/>

### **Example diagram for online practical**

The following links contain the example connection of equipments by using the images of the equipments. The students who do the simulated practical will need to prepare the diagrams as shown in the example.

<http://uploading.com/files/611ea98m/Example%2Bdiagram%2Bfor%2Bonline%2Bpractical.pdf/>

<http://uploading.com/files/mbc48256/Example%2Bdiagram%2Bfor%2Bonline%2Bpractical.zip/>

The followings are examples of the practical tasks performed in study areas related to power, power electronics and renewable energy

- POWER ENGINEERING

<http://uploading.com/files/4ec3b21f/Power%2BEngineering.zip/>

- Renewable energy-PV installation

<http://uploading.com/files/7d79368a/Renewable%2BEnergy.zip/>

### **PART (3) COMPULSORY PRACTICALS FOR ALL POWER+POWER ELECTRONICS UNITS**

The practicals are to be viewed at the following links

- Practical Semester 1(A).pdf

<http://uploading.com/files/4a3m2a95/Practical%2BSemester%2B1%2528A%2529.zip/>

- Digital Practical



<http://uploading.com/files/3d324765/Digital%2BPractical.zip/>

The students need to study the circuit connection , instruction and equipments . Then they will have to draw the physical connection diagrams by using the images in the following links as given in example.

<http://uploading.com/files/m7m1993d/Practical%2BEquipments%2Bfor%2BOnline%2Blab.pdf/>

### List of compulsory practicals

	<b>Practical</b>	<b>Page number</b>	<b>Study area</b>
1	Investigating DC variable speed drive system , tacho meter, transducer	2,3,4,5,6,7,8	(4)Process Control
2	Amplifier gain	9,10,11	(3)Power Electronics
3	Investigating characteristics of SCR	12 to 23 + 89+90+91	(3)Power Electronics
4	Investigating the operation of over current relay	37,34,25,26,27,28,29,30,31	(1)Power System
5	Comparing AC & DC Distribution system	39,32,34,35,36	(1)Power System
6	Investigating single phase and three phase rectification	40,41,42,43,44,45,46,47,48	(3)Power Electronics
7	Three terminal regulator	53,54,49,50,51,52	(3)Power Electronics
8	Current & voltage transducer	60,61,55,56,57,58,59	(4)Process Control
9	Effect of transformer on line power loss	71,62,63,64,65,66,67,68,69,70	(1)Power System
10	Tee and Pi equivalent line	85,86,87,73,74,75,76,77,78,79,80,81,82,83,84	(1)Power System
11	Variable dc drive with rectifier	94,95,96,97,92,93	(2)Electrical Machines Drive System + Magnetics

<http://uploading.com/files/b4ce1m5d/G049%2BPractical%2B3%2BPhase.zip/>

	<b>Practical</b>	<b>Page number</b>	<b>Study area</b>
12	Three phase line and phase voltage measurement	10,9,3,4	(6)Electrical Fundamental
13	Three phase power measurement by two watt meters	11,5,6	(6)Electrical Fundamental
14	Three power measurement by power analyzer	13,7,8	(6)Electrical Fundamental

### Submission check list

**(A) Practical Assignment**

- (1) Name of practical
- (2) List of equipments used in practical (Page number of equipment + Name of equipment)+Method analysis
- (3) Circuit connection by using above equipments (Refer example diagram)
- (4) Print out the PDF file that containing equipments
- (5) Cut the picture, paste on blank sheet
- (6) Draw the circuit diagrams
- (7) Result/Table (Only for the practicals using real equipments)

**(B) Practical Project**

Fill in the worksheet

- (1) Name of practical
- (2) Background theory
- (3) List of equipments used in practical (Page number of equipment + Name of equipment)+ Method analysis
- (4) Circuit connection by using above equipments (Refer example diagram)
- (5) Print out the PDF file that containing equipments
- (6) Cut the picture, paste on blank sheet
- (7) Draw the circuit diagrams
- (8) Result/Table (Only for the practicals using real equipments)
- (9) Reference

**Projects**

Select the title for any \_\_\_\_\_ practicals listed in

- Study area (1)Power System
- Study area (2)Electrical Machines Drive System + Magnetics
- Study area (3)Power Electronics
- Study area (4)Process Control
- Study area(5)Renewable Energy
- Study area(6)Electrical Fundamental

**Method analysis**

You need to find the relevant practical instructions from

**Practical1Instruction**

<http://powersemester2.zoomshare.com/files/Practical1Instruction.zip>

**Practical3-2009**

<http://powersemester2.zoomshare.com/files/Practical3-2009.zip>

**Practical\_1-2009Instruction**

[http://powersemester3.zoomshare.com/files/Practical\\_1-2009Instruction.zip](http://powersemester3.zoomshare.com/files/Practical_1-2009Instruction.zip)

**Practical\_2-2009Instruction1**

[http://powersemester3.zoomshare.com/files/Practical\\_2-2009Instruction1.zip](http://powersemester3.zoomshare.com/files/Practical_2-2009Instruction1.zip)

**Practical\_2-2009Instruction2**

[http://powersemester3.zoomshare.com/files/Practical\\_2-2009Instruction2.zip](http://powersemester3.zoomshare.com/files/Practical_2-2009Instruction2.zip)

**Practical\_3\_Instruction**

[http://powersemester3.zoomshare.com/files/Practical\\_3\\_Instruction\\_.zip](http://powersemester3.zoomshare.com/files/Practical_3_Instruction_.zip)

General Practical Reference for all power diploma units-G069+G070

<http://uploading.com/files/2m693269/General%2BPractical%2BReference%2Bfor%2B all%2Bpower%2Bdiploma%2Bunits-G069%2BG070.zip/>

**Equipments analysis**

You need to refer the following files

**Practical1-2010Part1**

<http://powersemester2.zoomshare.com/files/Practical1-2010Part1.zip>

**Practical1-2010Part2**

<http://powersemester2.zoomshare.com/files/Practical1-2010Part2.zip>

**Practical1-2010Part3**

<http://powersemester2.zoomshare.com/files/Practical1-2010Part3.zip>

**Equipments****Practical1-2009Equipmen1a**

<http://powersemester2.zoomshare.com/files/Practical1-2009Equipmen1a.zip>

**Practical1-2009Equipmen1b**

<http://powersemester2.zoomshare.com/files/Practical1-2009Equipmen1b.zip>

**Practical1-2009Equipment2a**

<http://powersemester2.zoomshare.com/files/Practical1-2009Equipment2a.zip>

### **Practical1-2009Equipment2b**

<http://powersemester2.zoomshare.com/files/Practical1-2009Equipment2b.zip>

List of equipments used in practical (Page number of equipment + Name of equipment)+  
Method analysis

Circuit connection by using above equipments (Refer example diagram)

### **Data analysis**

#### **Lab\_Instruction\_data\_1**

[http://powersemester2.zoomshare.com/files/Lab\\_Instruction\\_data\\_1.zip](http://powersemester2.zoomshare.com/files/Lab_Instruction_data_1.zip)

#### **Data**

#### **Lab\_Data\_1**

[http://powersemester2.zoomshare.com/files/Lab\\_Data\\_1.zip](http://powersemester2.zoomshare.com/files/Lab_Data_1.zip)

#### **Lab\_Data\_2**

[http://powersemester2.zoomshare.com/files/Lab\\_Data\\_2.zip](http://powersemester2.zoomshare.com/files/Lab_Data_2.zip)

#### **Lab\_Data\_3**

[http://powersemester2.zoomshare.com/files/Lab\\_Data\\_3.zip](http://powersemester2.zoomshare.com/files/Lab_Data_3.zip)

## **PART (4) Study area (1)Power System Practicals**

Power System-G015+G046+G037+G038+G039+G042 Work Performance Project

### **List of practicals**

1. CT PT- Ratio measurement
2. CT Ratio
3. Real power, reactive power, apparent power
4. Transmission line project
5. HT line design
6. Inductive reactance of series coil
7. Line air capacitance test
8. Line insulator capacitance measurement
9. Load centre
10. Over current relay
11. Underground cable capacitance test

12. Voltage profile chart
13. Pi and Tee network
14. Transformer effect on transmission line loss
15. Transformer open circuit & short circuit test
16. Transformer polarity test
17. DC line efficiency

**(a) Literature study**

Source of reference literatures

[www.1790817794.zoomshare.com](http://www.1790817794.zoomshare.com)

G015+7762AA+7762AE+7762AG

UEENEEG015		Find and rectify faults in energy supply network equipment
7762AA	EA153	Electrical distribution 1
7762AE	EB112	Power system protection
7762AG	EB114	Power systems operation

[http://powerclass.zoomshare.com/files/G015\\_G037\\_G038\\_G030Pt1\\_7762AG\\_Notes.doc](http://powerclass.zoomshare.com/files/G015_G037_G038_G030Pt1_7762AG_Notes.doc)

[http://powerclass.zoomshare.com/files/G015\\_G042\\_G037\\_G038\\_G039\\_Part\\_2\\_Notes.doc](http://powerclass.zoomshare.com/files/G015_G042_G037_G038_G039_Part_2_Notes.doc)

[http://powerclass.zoomshare.com/files/Tutorial\\_answers\\_for\\_G015\\_G047\\_G049\\_G043\\_G045\\_G040\\_G042.doc](http://powerclass.zoomshare.com/files/Tutorial_answers_for_G015_G047_G049_G043_G045_G040_G042.doc)

[http://powerclass.zoomshare.com/files/7762AA\\_Module\\_Book\\_Modified\\_Jan\\_08.zip](http://powerclass.zoomshare.com/files/7762AA_Module_Book_Modified_Jan_08.zip)

G046+7762AE

UEENEEG046		Develop engineering solutions for energy supply system protection problems
7762AE	EB112	Power system protection

[http://powerclass.zoomshare.com/files/G046\\_7762AE\\_Notes.doc](http://powerclass.zoomshare.com/files/G046_7762AE_Notes.doc)

G047+7762AH+4269T

UEENEEG047		Provide computational solutions to power engineering problems
7762AH	EA157	Power systems fundamentals
4269T	EB164	Transmission lines 1

[http://powerclass.zoomshare.com/files/G047\\_4269T\\_7762AH.zip](http://powerclass.zoomshare.com/files/G047_4269T_7762AH.zip)

G042+4269T+7762AH

UEENEEG042B		Diagnose and rectify faults in electrical energy supply transmission systems
7762AH	EA157	Power systems fundamentals
4269T	EB164	Transmission lines 1

[http://powersemester1.zoomshare.com/files/G042\\_Part\\_3\\_Notes.doc](http://powersemester1.zoomshare.com/files/G042_Part_3_Notes.doc)

[http://powersemester1.zoomshare.com/files/G037\\_G038\\_G030Pt1\\_7762AG\\_Notes.doc](http://powersemester1.zoomshare.com/files/G037_G038_G030Pt1_7762AG_Notes.doc)

[http://powersemester1.zoomshare.com/files/G015\\_G042\\_G037\\_G038\\_G039\\_Part\\_2\\_Notes.doc](http://powersemester1.zoomshare.com/files/G015_G042_G037_G038_G039_Part_2_Notes.doc)

[http://powersemester1.zoomshare.com/files/G015\\_G037\\_G038\\_G030Pt1\\_7762AG\\_Notes.doc](http://powersemester1.zoomshare.com/files/G015_G037_G038_G030Pt1_7762AG_Notes.doc)

UEENEEG037B		Diagnose and rectify faults in energy supply apparatus
-------------	--	--

[http://powersemester3.zoomshare.com/files/ESI\\_8\\_Insulation\\_1.zip](http://powersemester3.zoomshare.com/files/ESI_8_Insulation_1.zip)

[http://powersemester3.zoomshare.com/files/ESI\\_8\\_Insulation\\_2.zip](http://powersemester3.zoomshare.com/files/ESI_8_Insulation_2.zip)

[http://powersemester3.zoomshare.com/files/ESI\\_9.1\\_Protection\\_Relay\\_Construction.zip](http://powersemester3.zoomshare.com/files/ESI_9.1_Protection_Relay_Construction.zip)

[http://powersemester3.zoomshare.com/files/ESI\\_9.2Test\\_Equipment.zip](http://powersemester3.zoomshare.com/files/ESI_9.2Test_Equipment.zip)

[http://powersemester3.zoomshare.com/files/ESI\\_33.1\\_Power\\_Quality\\_Concept.zip](http://powersemester3.zoomshare.com/files/ESI_33.1_Power_Quality_Concept.zip)

[http://powersemester3.zoomshare.com/files/ESI\\_33.2\\_Harmonic\\_in\\_capacitor.zip](http://powersemester3.zoomshare.com/files/ESI_33.2_Harmonic_in_capacitor.zip)

[http://powersemester3.zoomshare.com/files/ESI\\_33.3\\_Harmoniceffect\\_on\\_machines.zip](http://powersemester3.zoomshare.com/files/ESI_33.3_Harmoniceffect_on_machines.zip)

[http://powersemester3.zoomshare.com/files/ESI\\_33.4\\_Harmonic\\_in\\_synchronous\\_machines.zip](http://powersemester3.zoomshare.com/files/ESI_33.4_Harmonic_in_synchronous_machines.zip)

[http://powersemester3.zoomshare.com/files/ESI\\_33.5\\_Harmonic\\_in\\_transformer.zip](http://powersemester3.zoomshare.com/files/ESI_33.5_Harmonic_in_transformer.zip)

[http://powersemester3.zoomshare.com/files/ESI\\_33.6\\_Power\\_Quality\\_Improvement\\_Capacitor\\_bank.zip](http://powersemester3.zoomshare.com/files/ESI_33.6_Power_Quality_Improvement_Capacitor_bank.zip)

[http://powersemester3.zoomshare.com/files/ESI\\_33.7\\_Power\\_Quality\\_Improvement-Filter.zip](http://powersemester3.zoomshare.com/files/ESI_33.7_Power_Quality_Improvement-Filter.zip)

[http://powersemester3.zoomshare.com/files/ESI\\_33.8\\_Power\\_Quality\\_Improvement-General.zip](http://powersemester3.zoomshare.com/files/ESI_33.8_Power_Quality_Improvement-General.zip)

[http://powersemester3.zoomshare.com/files/ESI\\_33.9\\_Power\\_Quality\\_Improvement-Power\\_Conditioner.zip](http://powersemester3.zoomshare.com/files/ESI_33.9_Power_Quality_Improvement-Power_Conditioner.zip)

UEENEEG038B		Diagnose and rectify faults in electrical energy distribution
-------------	--	---

		systems
--	--	---------

[http://powersemester3.zoomshare.com/files/ESI10.1\\_HV\\_equipments.zip](http://powersemester3.zoomshare.com/files/ESI10.1_HV_equipments.zip)

[http://powersemester3.zoomshare.com/files/ESI10.2\\_Substation\\_equipments.zip](http://powersemester3.zoomshare.com/files/ESI10.2_Substation_equipments.zip)

[http://powersemester3.zoomshare.com/files/ESI\\_18.1\\_Substation\\_equipments\\_1.zip](http://powersemester3.zoomshare.com/files/ESI_18.1_Substation_equipments_1.zip)

[http://powersemester3.zoomshare.com/files/ESI\\_18.2\\_Substation\\_equipments\\_2.zip](http://powersemester3.zoomshare.com/files/ESI_18.2_Substation_equipments_2.zip)

[http://powersemester3.zoomshare.com/files/ESI\\_18.3\\_Substation\\_equipments\\_3.zip](http://powersemester3.zoomshare.com/files/ESI_18.3_Substation_equipments_3.zip)

UEENEG039B		Diagnose and rectify faults in distributed generation systems
UEENEEK048A		Install, configure and commission grid connected photovoltaic power systems

[http://powersemester3.zoomshare.com/files/ESI12\\_14\\_Harmonic.zip](http://powersemester3.zoomshare.com/files/ESI12_14_Harmonic.zip)

[http://powersemester3.zoomshare.com/files/ESI12\\_14\\_Reactor.zip](http://powersemester3.zoomshare.com/files/ESI12_14_Reactor.zip)

[http://powersemester3.zoomshare.com/files/ESI12\\_14\\_Syn\\_Motor\\_Generator.zip](http://powersemester3.zoomshare.com/files/ESI12_14_Syn_Motor_Generator.zip)

[http://powersemester3.zoomshare.com/files/ESI\\_19.1\\_Computer\\_Control.zip](http://powersemester3.zoomshare.com/files/ESI_19.1_Computer_Control.zip)

[http://powersemester3.zoomshare.com/files/ESI\\_19.4\\_Turbine\\_Control.zip](http://powersemester3.zoomshare.com/files/ESI_19.4_Turbine_Control.zip)

[http://powersemester3.zoomshare.com/files/ESI\\_19.2\\_Generator\\_Control\\_Load\\_Flow.zip](http://powersemester3.zoomshare.com/files/ESI_19.2_Generator_Control_Load_Flow.zip)

[http://powersemester3.zoomshare.com/files/ESI\\_19.3\\_Generator\\_.zip](http://powersemester3.zoomshare.com/files/ESI_19.3_Generator_.zip)

[http://powersemester3.zoomshare.com/files/ESI\\_22.1\\_Generator\\_Study.zip](http://powersemester3.zoomshare.com/files/ESI_22.1_Generator_Study.zip)

[http://powersemester3.zoomshare.com/files/ESI\\_22.2\\_Voltage\\_surge\\_control.zip](http://powersemester3.zoomshare.com/files/ESI_22.2_Voltage_surge_control.zip)

[http://powersemester3.zoomshare.com/files/ESI\\_24\\_Modern\\_Power\\_System.zip](http://powersemester3.zoomshare.com/files/ESI_24_Modern_Power_System.zip)

### **(b) Method study**

Refer the files included in power system G015+G046+G037+G038+G039+G042 work performance project

+

General Practical Reference for all power diploma units-G069+G070

**<http://uploading.com/files/2m693269/General%2BPractical%2BReference%2Bfor%2B all%2Bpower%2Bdiploma%2Bunits-G069%2BG070.zip/>**

**Method analysis**

You need to find the relevant practical instructions from

**Practical1Instruction**

<http://powersemester2.zoomshare.com/files/Practical1Instruction.zip>

1,2,3,6,7,9,10,11,18,22,23,24,25,29,30

**Practical3-2009**

<http://powersemester2.zoomshare.com/files/Practical3-2009.zip>

**Practical\_1-2009Instruction**

[http://powersemester3.zoomshare.com/files/Practical\\_1-2009Instruction.zip](http://powersemester3.zoomshare.com/files/Practical_1-2009Instruction.zip)

Page 8,9,10,11,12,13,14,15,17,21,22,30,34,35,36,37,39

**Practical\_2-2009Instruction1**

[http://powersemester3.zoomshare.com/files/Practical\\_2-2009Instruction1.zip](http://powersemester3.zoomshare.com/files/Practical_2-2009Instruction1.zip)

Page 2,3,4,17,18,19,20,21,22,26,27,28,29,30,35,36,37,40,41,42,44,45,46,47,48,49,50,53,54,55

**Practical\_2-2009Instruction2**

[http://powersemester3.zoomshare.com/files/Practical\\_2-2009Instruction2.zip](http://powersemester3.zoomshare.com/files/Practical_2-2009Instruction2.zip)

Page 1,2,3,4,11,12,13,14,15,16,17,18,19,36,37,38

**Practical\_3\_Instruction**

[http://powersemester3.zoomshare.com/files/Practical\\_3\\_Instruction\\_.zip](http://powersemester3.zoomshare.com/files/Practical_3_Instruction_.zip)

Page 7,8,9

**(c) Equipments analysis**

You need to refer the following files

**Practical1-2010Part1**

<http://powersemester2.zoomshare.com/files/Practical1-2010Part1.zip>

**Practical1-2010Part2**

<http://powersemester2.zoomshare.com/files/Practical1-2010Part2.zip>



**Practical1-2010Part3**

<http://powersemester2.zoomshare.com/files/Practical1-2010Part3.zip>

**Equipments****Practical1-2009Equipmen1a**

<http://powersemester2.zoomshare.com/files/Practical1-2009Equipmen1a.zip>

Page 18,19,20,21,22,23,24,25,26,27,28,29,30,31

**Practical1-2009Equipmen1b**

<http://powersemester2.zoomshare.com/files/Practical1-2009Equipmen1b.zip>

Page 4,5,6,8,11,12,13,14,15,16,17,18,19,20,21,22,24,25,26,30,31,32,33,34

**Practical1-2009Equipment2a**

<http://powersemester2.zoomshare.com/files/Practical1-2009Equipment2a.zip>

Page 5,6,7,17,18,19,20,44,45,46

**Practical1-2009Equipment2b**

<http://powersemester2.zoomshare.com/files/Practical1-2009Equipment2b.zip>

Page 2,3,4,5,6,7,8,9,10,11,12,13,16,17,18,19,20,21,22,23,24,25,27,28,29,30,31,32,33,34,35,36,37,38,39,40

List of equipments used in practical (Page number of equipment + Name of equipment)+  
Method analysis

Circuit connection by using above equipments (Refer example diagram)

**(d) Data analysis**

<http://powersemester2.zoomshare.com/files/Practical1-2010Part1.zip>

Page 1,2,3,4,5,6,36,37,38,39,40

<http://powersemester2.zoomshare.com/files/Practical1-2010Part2.zip>

Page 17,18,19,20,37,38,39,40,41,42,43,44,45

<http://powersemester2.zoomshare.com/files/Practical1-2010Part3.zip>

Page 1,2,3,4,5,6,7,8,9,10,11,12,13,14,15,16,17,18

**Lab\_Instruction\_data\_1**

[http://powersemester2.zoomshare.com/files/Lab\\_Instruction\\_data\\_1.zip](http://powersemester2.zoomshare.com/files/Lab_Instruction_data_1.zip)

## Data

### Lab\_Data\_1

[http://powersemester2.zoomshare.com/files/Lab\\_Data\\_1.zip](http://powersemester2.zoomshare.com/files/Lab_Data_1.zip)

### Lab\_Data\_2

[http://powersemester2.zoomshare.com/files/Lab\\_Data\\_2.zip](http://powersemester2.zoomshare.com/files/Lab_Data_2.zip)

### Lab\_Data\_3

[http://powersemester2.zoomshare.com/files/Lab\\_Data\\_3.zip](http://powersemester2.zoomshare.com/files/Lab_Data_3.zip)

## **PART (5) Study area (2)Electrical Machines Drive System + Magnetics Practicals**

Electrical Machines+Magnetics-G001+E029+G040+G043+G044+G045 Work Performance Projects

<http://uploading.com/files/d8f57991/Electrical%2BMachines%2BMagnetics-G001%2BE029%2BG040%2BG043%2BG044%2BG045%2BWork%2BPerformance%2BProjects.zip/>

DC Machine G044 Practicals

<http://uploading.com/files/b23a4b6e/DC%2BMachine%2BG044%2BPracticals.zip/>

### **List of practicals**

1. E029 practical 1/Practical E029 Induction motor star delta test
2. E029 practical 1/Practical E029-Motor
3. E029 practical 1/Practical E029-Testing motor polarity
4. Practical G044-DC generator characteristics test
5. Three phase motor no load test
6. Three phase motor speed measurement
7. AC-DC drive
8. Auto transformer test
9. Coil inductance
10. CT ratio
11. Mutual inductance
12. Practical G040 –CT PT Power system measurement
13. Practical G040-Power transformer % Regulation
14. Practical G040-Transformer connection
15. Practical-G040-Transformer open circuit/ short circuit test

16. Variable speed drive
17. DC motor speed test –Permanent magnet motor
18. DC motor speed test –Wound field motor

**(a) Literature study**

**G001+G002**

UEENEEG001		Solve problems in electromagnetic circuits
UEENEEG002		Solve problems in single and three phase low voltage circuits
7793A	NE160	Electrical principles 1
7793B	NE161	Electrical principles 2

[http://powerclass.zoomshare.com/files/G001\\_Part\\_1.zip](http://powerclass.zoomshare.com/files/G001_Part_1.zip)

[http://powerclass.zoomshare.com/files/G001\\_Part\\_2.zip](http://powerclass.zoomshare.com/files/G001_Part_2.zip)

<http://powerclass.zoomshare.com/files/G002.zip>

**G040+7762AD**

UEENEEG040		Develop engineering solutions for energy supply power transformer problems
7762AD	EB113	Power transformers

[http://powerclass.zoomshare.com/files/G040\\_7762AD\\_Notes.doc](http://powerclass.zoomshare.com/files/G040_7762AD_Notes.doc)

**E029**

UEENEEE029		Solve electrotechnical problems
------------	--	---------------------------------

[http://powerclass.zoomshare.com/files/E029\\_Motor\\_Control\\_1.zip](http://powerclass.zoomshare.com/files/E029_Motor_Control_1.zip)

[http://powerclass.zoomshare.com/files/E029\\_Motor\\_Control\\_2.zip](http://powerclass.zoomshare.com/files/E029_Motor_Control_2.zip)

<http://powerclass.zoomshare.com/files/E047Mech.zip>

**G043+G045 +7762AF**

UEENEEG043B		Develop engineering solution for synchronous machine problems
UEENEEG045B		Develop engineering solutions for induction motor problems
7762AF	EB110	Advanced AC machines

[http://powersemester1.zoomshare.com/files/G043\\_G045\\_7762AF\\_Notes.doc](http://powersemester1.zoomshare.com/files/G043_G045_7762AF_Notes.doc)

[http://powersemester1.zoomshare.com/files/G043\\_G045\\_Part\\_1\\_7762AF\\_Notes.doc](http://powersemester1.zoomshare.com/files/G043_G045_Part_1_7762AF_Notes.doc)

**G044+7762AC**

UEENEEG044B		Develop engineering solutions for d.c. machine problems
7762AC	EA108	Advanced DC machines

[http://powersemester1.zoomshare.com/files/G044\\_7762AC1.zip](http://powersemester1.zoomshare.com/files/G044_7762AC1.zip)

[http://powersemester1.zoomshare.com/files/G044\\_7762AC2.zip](http://powersemester1.zoomshare.com/files/G044_7762AC2.zip)

### **MACHINE REPAIR+PROCESS CONTROL**

#### **MachineControlCkt1.zip**

<http://advanceddiplomastage4g.zoomshare.com/files/MachineControlCkt1.zip>

#### **MachineControlCkt2.zip**

<http://advanceddiplomastage4g.zoomshare.com/files/MachineControlCkt2.zip>

#### **MachineControlCkt3.zip**

<http://advanceddiplomastage4g.zoomshare.com/files/MachineControlCkt3.zip>

#### **MachineRepair1.zip**

<http://advanceddiplomastage4g.zoomshare.com/files/MachineRepair1.zip>

#### **MachineRepair2.zip**

<http://advanceddiplomastage4g.zoomshare.com/files/MachineRepair2.zip>

#### **MachineRepair3.zip**

<http://advanceddiplomastage4g.zoomshare.com/files/MachineRepair3.zip>

### **(b) Method study**

Refer the files included in Electrical Machines +Magnatics  
G001+E029+G040+G043+G045+G044 Work performance project

+

General Practical Reference for all power diploma units-G069+G070

<http://uploading.com/files/2m693269/General%2BPractical%2BReference%2Bfor%2B all%2Bpower%2Bdiploma%2Bunits-G069%2BG070.zip/>

**Method analysis**

You need to find the relevant practical instructions from

**Practical1Instruction**

<http://powersemester2.zoomshare.com/files/Practical1Instruction.zip>

Page 3,4,5,13,14,15,16,19,20,21,22,32,33

**Practical3-2009**

<http://powersemester2.zoomshare.com/files/Practical3-2009.zip>

**Practical\_1-2009Instruction**

[http://powersemester3.zoomshare.com/files/Practical\\_1-2009Instruction.zip](http://powersemester3.zoomshare.com/files/Practical_1-2009Instruction.zip)

Page 14,15,16,17,18,19,20,21,24,25,26,27,28,29,30,39,40,41,42,43

**Practical\_2-2009Instruction1**

[http://powersemester3.zoomshare.com/files/Practical\\_2-2009Instruction1.zip](http://powersemester3.zoomshare.com/files/Practical_2-2009Instruction1.zip)

Page 2,3,4,11,15,16,17,18,21,22,23,24,25,31,32,33,34,51,52

**Practical\_2-2009Instruction2**

[http://powersemester3.zoomshare.com/files/Practical\\_2-2009Instruction2.zip](http://powersemester3.zoomshare.com/files/Practical_2-2009Instruction2.zip)

Page 6,7,8,9,15,19,20,21,22,23,24,25,26

**Practical\_3\_Instruction**

[http://powersemester3.zoomshare.com/files/Practical\\_3\\_Instruction\\_.zip](http://powersemester3.zoomshare.com/files/Practical_3_Instruction_.zip)

Page 3,4,5,13,14,15,25,26

**(c) Analysis of equipments**

Refer the files included in Electrical Machines +Magnatics  
G001+E029+G040+G043+G045+G044 Work performance project

+

General Practical Reference for all power diploma units-G069+G070

<http://uploading.com/files/2m693269/General%2BPractical%2BReference%2Bfor%2B all%2Bpower%2Bdiploma%2Bunits-G069%2BG070.zip/>

You need to refer the following files

### **Practical1-2010Part1**

<http://powersemester2.zoomshare.com/files/Practical1-2010Part1.zip>

Page 1,2,3,4,7,8,9,10,11,12,13,22,23,24,26,27,28,29,30,31,32,33,34

### **Practical1-2010Part2**

<http://powersemester2.zoomshare.com/files/Practical1-2010Part2.zip>

Page 2,3,4,5,6,7,8,9,10,11,12,13,14,15,16,32,33,34,35,36,37

### **Practical1-2010Part3**

<http://powersemester2.zoomshare.com/files/Practical1-2010Part3.zip>

NIL

### **Practical3-2009**

<http://powersemester2.zoomshare.com/files/Practical3-2009.zip>

Page 1,2,3,4,5,6,7,8,9,10,54,55,56,57,65,67,68,69

DC Machine G044 Practicals

<http://uploading.com/files/b23a4b6e/DC%2BMachine%2BG044%2BPracticals.zip/>

## **Equipments**

### **Practical1-2009Equipmen1a**

<http://powersemester2.zoomshare.com/files/Practical1-2009Equipmen1a.zip>

Page 13,14,15,31,32,33,34,35,35,36,37,38,39

### **Practical1-2009Equipmen1b**

<http://powersemester2.zoomshare.com/files/Practical1-2009Equipmen1b.zip>

Page 1,2,3,4,5,6,7,8,9,10

### **Practical1-2009Equipment2a**

<http://powersemester2.zoomshare.com/files/Practical1-2009Equipment2a.zip>

Page 17,18,19,20,21,22,23,24,25,26,27,28,29,30,31,32,33,34,35,36,37,38,39,40,41,42,43

### **Practical1-2009Equipment2b**

<http://powersemester2.zoomshare.com/files/Practical1-2009Equipment2b.zip>

Nil

List of equipments used in practical (Page number of equipment + Name of equipment)+  
Method analysis

Circuit connection by using above equipments (Refer example diagram)

### **(d) Data analysis**

[http://powersemester2.zoomshare.com/files/Lab\\_Instruction\\_data\\_1.zip](http://powersemester2.zoomshare.com/files/Lab_Instruction_data_1.zip)

<http://powersemester2.zoomshare.com/files/Practical1-2010Part1.zip>

<http://powersemester2.zoomshare.com/files/Practical1-2010Part2.zip>

<http://powersemester2.zoomshare.com/files/Practical1-2010Part3.zip>

### **Lab\_Instruction\_data\_1**

[http://powersemester2.zoomshare.com/files/Lab\\_Instruction\\_data\\_1.zip](http://powersemester2.zoomshare.com/files/Lab_Instruction_data_1.zip)

Data

### **Lab\_Data\_1**

[http://powersemester2.zoomshare.com/files/Lab\\_Data\\_1.zip](http://powersemester2.zoomshare.com/files/Lab_Data_1.zip)

### **Lab\_Data\_2**

[http://powersemester2.zoomshare.com/files/Lab\\_Data\\_2.zip](http://powersemester2.zoomshare.com/files/Lab_Data_2.zip)

### **Lab\_Data\_3**

[http://powersemester2.zoomshare.com/files/Lab\\_Data\\_3.zip](http://powersemester2.zoomshare.com/files/Lab_Data_3.zip)

## **PART (6) Study area (3)Power Electronics Practicals**

Power Electronics+Analog Electronics-H025+H026+H045 Work Performance Projects

<http://uploading.com/files/cdaa8bd3/Power%2BElectronics%2BAnalog%2BElectronics-H025%2BH026%2BH045%2BWork%2BPerformance%2BProjects.zip/>

**List of practicals**

1. Class A,B Amplifier
2. Digital circuit
3. Digital counter
4. Inverting, Non inverting amplifier
5. Power control devices
6. Practical-H025+H026 –SCR Phase control
7. Practical-H025 Inverting amplifier
8. Practical- H025-Op-amp comparator
9. Practical-H025-Precision half wave amplifier
10. Practical H025-Variable frequency drive
11. Practical-H026-Three phase rectifier
12. Practical-H026-Three terminals regulator
13. Practical-H026-PWM practical
14. Practical-H026-SCR Drive system
15. Practical-H026-Variable drive system
16. Practical-H045-Mini lab Op-amp
17. Rectification

**(a) Literature study****H045+7761A**

UEENEEH045		Develop solutions to analogue electronic problems
7761A	EA100	Analogue electronics 1

<http://powerclass.zoomshare.com/files/Analog1.zip>

<http://powerclass.zoomshare.com/files/Analog2.zip>

**H025**

UEENEEH025		Provide solutions to single phase electronic power control problems
8273Z	NE064	Variable speed drives

[http://powerteaching.zoomshare.com/files/H025\\_Operational\\_Amplifier.zip](http://powerteaching.zoomshare.com/files/H025_Operational_Amplifier.zip)

**H026**

UEENEEH026		Provide solutions to polyphase electronic power control problems
8273Z	NE064	Variable speed drives

[http://powerteaching.zoomshare.com/files/H026\\_3\\_Ph\\_Power\\_Control\\_Electronics\\_1.zip](http://powerteaching.zoomshare.com/files/H026_3_Ph_Power_Control_Electronics_1.zip)

[http://powerteaching.zoomshare.com/files/H026\\_3\\_Ph\\_Power\\_Control\\_Electronics\\_2.zip](http://powerteaching.zoomshare.com/files/H026_3_Ph_Power_Control_Electronics_2.zip)



[http://powerteaching.zoomshare.com/files/H026\\_3\\_Ph\\_Power\\_Control\\_Electronics\\_3.zip](http://powerteaching.zoomshare.com/files/H026_3_Ph_Power_Control_Electronics_3.zip)

[http://powerteaching.zoomshare.com/files/H026\\_3\\_Ph\\_Power\\_Control\\_Electronics\\_4.zip](http://powerteaching.zoomshare.com/files/H026_3_Ph_Power_Control_Electronics_4.zip)

## DC Power Supply

UEENEEH011B

Troubleshoot d.c. power supplies with single phase input

DCPowerSupply.zip

<http://16051.zoomshare.com/files/DCPowerSupply.zip>

## AMPLIFIER

UEENEEH013B		Troubleshoot amplifiers
UEENEEH039B		Troubleshoot basic amplifiers

### Amplifier (1)

<http://kyawnaing625.zoomshare.com/files/Amp/Amp1.zip>

<http://kyawnaing625.zoomshare.com/files/Amp/Amp2.zip>

[http://kyawnaing625.zoomshare.com/files/Amp/Amp3\\_0.zip](http://kyawnaing625.zoomshare.com/files/Amp/Amp3_0.zip)

<http://kyawnaing625.zoomshare.com/files/Amp/Amp4.zip>

<http://kyawnaing625.zoomshare.com/files/Amp/Amp5.zip>

<http://kyawnaing625.zoomshare.com/files/Amp/Amp6.zip>

### Amplifier (2)

<http://kyawnaing625.zoomshare.com/files/Amp/AMPa.zip>

<http://kyawnaing725.zoomshare.com/files/Amp/AMPb.zip>

<http://kyawnaing725.zoomshare.com/files/Amp/AMPc.zip>

<http://kyawnaing725.zoomshare.com/files/Amp/AMPd.zip>

<http://kyawnaing725.zoomshare.com/files/Amp/AMPe.zip>

### (b) Method study

Refer the files included in Power Electronics +Analogue Electronics H025+H026+H045  
Work performance project

+

General practical reference for all power diploma units G069+G070

<http://uploading.com/files/2m693269/General%2BPractical%2BReference%2Bfor%2B all%2Bpower%2Bdiploma%2Bunits-G069%2BG070.zip/>

### **Method analysis**

You need to find the relevant practical instructions from

#### **Practical1Instruction**

<http://powersemester2.zoomshare.com/files/Practical1Instruction.zip>

14,15

#### **Practical3-2009**

<http://powersemester2.zoomshare.com/files/Practical3-2009.zip>

#### **Practical\_1-2009Instruction**

[http://powersemester3.zoomshare.com/files/Practical\\_1-2009Instruction.zip](http://powersemester3.zoomshare.com/files/Practical_1-2009Instruction.zip)

Page 34,40,41 to 58

#### **Practical\_2-2009Instruction1**

[http://powersemester3.zoomshare.com/files/Practical\\_2-2009Instruction1.zip](http://powersemester3.zoomshare.com/files/Practical_2-2009Instruction1.zip)

49,54

#### **Practical\_2-2009Instruction2**

[http://powersemester3.zoomshare.com/files/Practical\\_2-2009Instruction2.zip](http://powersemester3.zoomshare.com/files/Practical_2-2009Instruction2.zip)

41 to 58

#### **Practical\_3\_Instruction**

[http://powersemester3.zoomshare.com/files/Practical\\_3\\_Instruction\\_.zip](http://powersemester3.zoomshare.com/files/Practical_3_Instruction_.zip)

25,26

### **(c) Analysis of equipments**

Refer the files included in Power Electronics +Analogue Electronics H025+H026+H045 Work performance project

+

General practical reference for all power diploma units G069+G070

<http://uploading.com/files/2m693269/General%2BPractical%2BReference%2Bfor%2B all%2Bpower%2Bdiploma%2Bunits-G069%2BG070.zip/>

### **Equipments analysis**

You need to refer the following files

#### **Practical1-2010Part1**

<http://powersemester2.zoomshare.com/files/Practical1-2010Part1.zip>

Page 13 to 21 + 36 to 44

#### **Practical1-2010Part2**

<http://powersemester2.zoomshare.com/files/Practical1-2010Part2.zip>

Page 1, 21 to 31

#### **Practical1-2010Part3**

<http://powersemester2.zoomshare.com/files/Practical1-2010Part3.zip>

Page 19 to 31

### **Equipments**

#### **Practical1-2009Equipmen1a**

<http://powersemester2.zoomshare.com/files/Practical1-2009Equipmen1a.zip>

Page 1 to 12

#### **Practical1-2009Equipmen1b**

<http://powersemester2.zoomshare.com/files/Practical1-2009Equipmen1b.zip>

NIL

#### **Practical1-2009Equipment2a**

<http://powersemester2.zoomshare.com/files/Practical1-2009Equipment2a.zip>

Page 11 to 16

#### **Practical1-2009Equipment2b**

<http://powersemester2.zoomshare.com/files/Practical1-2009Equipment2b.zip>

NIL

List of equipments used in practical (Page number of equipment + Name of equipment)+  
Method analysis

Circuit connection by using above equipments (Refer example diagram)

#### **(d) Data analysis**

[http://powersemester2.zoomshare.com/files/Lab\\_Instruction\\_data\\_1.zip](http://powersemester2.zoomshare.com/files/Lab_Instruction_data_1.zip)

<http://powersemester2.zoomshare.com/files/Practical1-2010Part1.zip>

<http://powersemester2.zoomshare.com/files/Practical1-2010Part2.zip>

<http://powersemester2.zoomshare.com/files/Practical1-2010Part3.zip>

#### **Lab\_Instruction\_data\_1**

[http://powersemester2.zoomshare.com/files/Lab\\_Instruction\\_data\\_1.zip](http://powersemester2.zoomshare.com/files/Lab_Instruction_data_1.zip)

#### **Data**

#### **Lab\_Data\_1**

[http://powersemester2.zoomshare.com/files/Lab\\_Data\\_1.zip](http://powersemester2.zoomshare.com/files/Lab_Data_1.zip)

#### **Lab\_Data\_2**

[http://powersemester2.zoomshare.com/files/Lab\\_Data\\_2.zip](http://powersemester2.zoomshare.com/files/Lab_Data_2.zip)

#### **Lab\_Data\_3**

[http://powersemester2.zoomshare.com/files/Lab\\_Data\\_3.zip](http://powersemester2.zoomshare.com/files/Lab_Data_3.zip)

## **PART (7) Study area (4)Process Control Practicals**

Process Control-I006 Work Performance Projects

<http://uploading.com/files/29fdm2a1/Process%2BControl-I006%2BWork%2BPerformance%2BProjects.zip/>

#### **List of practicals**

1. Transducer (Voltage to voltage)
2. Transducer –RPM to Voltage
3. Signal characteristics
4. Digital practical 1 (Gates)
5. Digital practical 2 –(Combinational Logic)
6. Digital practical 4-(Boolean Algebra)
7. Digital practical 3-(De-Morgan theorem)

8. Digital practical 5-(Equivalent gate)
9. Digital 2 Practical 1 (7 segment display)
10. Digital 2 practical 2 (JK Flipflop)
11. Digital 2 practical 3 (Counter)
12. Digital 2 practical 4 (Shift register)
13. Digital 2 practical 6 (Parallel adder)
14. Digital 2 practical 9(LED Indicator)
15. Digital practical 6 (BCD Encoder)

**(a) Literature study**

I006

UEENEEI006B		Solve problems in process controllers, transmitters and converters
6032A	EA904	Control concepts
7761L	EA190	Electronic signals and systems

**AnalogDigitalSignalConditioning**

<http://powersemester1.zoomshare.com/files/AnalogDigitalSignalConditioning.zip>

**H085\_66\_I006\_Note\_1\_Sensors\_1**

[http://powersemester1.zoomshare.com/files/H085\\_66\\_I006\\_Note\\_1\\_Sensors\\_.zip](http://powersemester1.zoomshare.com/files/H085_66_I006_Note_1_Sensors_.zip)

**H085\_66\_I006\_Note\_2\_Sensors\_2**

[http://powersemester1.zoomshare.com/files/H085\\_66\\_I006\\_Note\\_2\\_Sensors\\_2\\_.zip](http://powersemester1.zoomshare.com/files/H085_66_I006_Note_2_Sensors_2_.zip)

**H085\_66\_I006\_Note\_3\_Sensors\_3**

[http://powersemester1.zoomshare.com/files/H085\\_66\\_I006\\_Note\\_3\\_Sensors\\_3\\_.zip](http://powersemester1.zoomshare.com/files/H085_66_I006_Note_3_Sensors_3_.zip)

**H085\_66\_I006\_Note\_4\_Control\_Concept1**

[http://powersemester1.zoomshare.com/files/H085\\_66\\_I006\\_Note\\_4\\_Control\\_Concept1\\_.zip](http://powersemester1.zoomshare.com/files/H085_66_I006_Note_4_Control_Concept1_.zip)

**H085\_66\_I006\_Note\_5\_Control\_Concept2**

[http://powersemester1.zoomshare.com/files/H085\\_66\\_I006\\_Note\\_5\\_Control\\_Concept2\\_.zip](http://powersemester1.zoomshare.com/files/H085_66_I006_Note_5_Control_Concept2_.zip)

**H085\_66\_I006\_Note\_6\_Electronics\_Signal**

[http://powersemester1.zoomshare.com/files/H085\\_66\\_I006\\_Note\\_6\\_Electronics\\_Signal\\_.zip](http://powersemester1.zoomshare.com/files/H085_66_I006_Note_6_Electronics_Signal_.zip)

**H085\_66\_I006\_Note\_8\_Process\_Control\_1**

[http://powersemester1.zoomshare.com/files/H085\\_66\\_I006\\_Note\\_8\\_Process\\_Control\\_1\\_.zip](http://powersemester1.zoomshare.com/files/H085_66_I006_Note_8_Process_Control_1_.zip)

**H085\_66\_I006\_Note\_9\_Process\_Control\_2**

[http://powersemester1.zoomshare.com/files/H085\\_66\\_I006\\_Note\\_9\\_Process\\_Control\\_2\\_.zip](http://powersemester1.zoomshare.com/files/H085_66_I006_Note_9_Process_Control_2_.zip)

**PLC\_Textbook1**

[http://powersemester1.zoomshare.com/files/PLC\\_Textbook1.zip](http://powersemester1.zoomshare.com/files/PLC_Textbook1.zip)

**PLC\_Textbook2**

[http://powersemester1.zoomshare.com/files/PLC\\_Textbook2.zip](http://powersemester1.zoomshare.com/files/PLC_Textbook2.zip)

**PLC\_Textbook3**

[http://powersemester1.zoomshare.com/files/PLC\\_Textbook3.zip](http://powersemester1.zoomshare.com/files/PLC_Textbook3.zip)

**PLC**

<http://powersemester1.zoomshare.com/files/PLC.zip>

**6487E.zip**

<http://powersemester1.zoomshare.com/files/6487E.zip>

### **PID (Proportional Integral Derivative) Control**

**PID.zip**

<http://esipowersystem4.zoomshare.com/files/PID.zip>

UEENEEI001B		Install and set up transducers and sensing devices
UEENEEI002B		Solve problems in pressure measurement systems
UEENEEI004B		Solve problems in flow measurement systems

UEENEEI005B		Solve problems in temperature measurement systems
-------------	--	---

I001

**H085\_66\_I006\_Note\_1\_Sensors 1**

[http://powersemester1.zoomshare.com/files/H085\\_66\\_I006\\_Note\\_1\\_Sensors\\_.zip](http://powersemester1.zoomshare.com/files/H085_66_I006_Note_1_Sensors_.zip)

**H085\_66\_I006\_Note\_2\_Sensors\_2**

[http://powersemester1.zoomshare.com/files/H085\\_66\\_I006\\_Note\\_2\\_Sensors\\_2\\_.zip](http://powersemester1.zoomshare.com/files/H085_66_I006_Note_2_Sensors_2_.zip)

**H085\_66\_I006\_Note\_3\_Sensors\_3**

[http://powersemester1.zoomshare.com/files/H085\\_66\\_I006\\_Note\\_3\\_Sensors\\_3\\_.zip](http://powersemester1.zoomshare.com/files/H085_66_I006_Note_3_Sensors_3_.zip)

I002+I004

**I002I004PressureFlowPnuematicReference.zip**

<http://advanceddiplomastage4c.zoomshare.com/files/I002I004PressureFlowPnuematicReference.zip>

I005

**I005TemperatureMeasurement.zip**

<http://advanceddiplomastage4c.zoomshare.com/files/I005TemperatureMeasurement.zip>

Process Control Practicals

**PLC\_Application\_Assignment.zip**

[http://advanceddiplomastage4d.zoomshare.com/files/PLC\\_Application\\_Assignment.zip](http://advanceddiplomastage4d.zoomshare.com/files/PLC_Application_Assignment.zip)

**Control\_Circuit\_Boards.zip**

[http://advanceddiplomastage4d.zoomshare.com/files/Control\\_Circuit\\_Boards.zip](http://advanceddiplomastage4d.zoomshare.com/files/Control_Circuit_Boards.zip)

**PLC\_Hardware\_Notes\_1.zip**

[http://advanceddiplomastage4d.zoomshare.com/files/PLC\\_Hardware\\_Notes\\_1.zip](http://advanceddiplomastage4d.zoomshare.com/files/PLC_Hardware_Notes_1.zip)

**PLC\_Hardware\_Notes\_2.zip**

[http://advanceddiplomastage4d.zoomshare.com/files/PLC\\_Hardware\\_Notes\\_2.zip](http://advanceddiplomastage4d.zoomshare.com/files/PLC_Hardware_Notes_2.zip)

**PLC\_Hardware\_Notes\_3.zip**

[http://advanceddiplomastage4d.zoomshare.com/files/PLC\\_Hardware\\_Notes\\_3.zip](http://advanceddiplomastage4d.zoomshare.com/files/PLC_Hardware_Notes_3.zip)

**PLC\_Hardware\_Notes\_4.zip**

[http://advanceddiplomastage4d.zoomshare.com/files/PLC\\_Hardware\\_Notes\\_4.zip](http://advanceddiplomastage4d.zoomshare.com/files/PLC_Hardware_Notes_4.zip)

**PLC\_Hardware\_Notes\_5.zip**

[http://advanceddiplomastage4d.zoomshare.com/files/PLC\\_Hardware\\_Notes\\_5.zip](http://advanceddiplomastage4d.zoomshare.com/files/PLC_Hardware_Notes_5.zip)

**PLC\_Hardware\_Notes\_6.zip**

[http://advanceddiplomastage4d.zoomshare.com/files/PLC\\_Hardware\\_Notes\\_6.zip](http://advanceddiplomastage4d.zoomshare.com/files/PLC_Hardware_Notes_6.zip)

**PLC\_Triology\_Advanced\_Programs.zip**

[http://advanceddiplomastage4d.zoomshare.com/files/PLC\\_Triology\\_Advanced\\_Programs.zip](http://advanceddiplomastage4d.zoomshare.com/files/PLC_Triology_Advanced_Programs.zip)

**PLC\_SCADA\_Project\_Example\_1.zip**

[http://advanceddiplomastage4d.zoomshare.com/files/PLC\\_SCADA\\_Project\\_Example\\_1.zip](http://advanceddiplomastage4d.zoomshare.com/files/PLC_SCADA_Project_Example_1.zip)

**PLC\_SCADA\_Project\_Example\_2.zip**

[http://advanceddiplomastage4d.zoomshare.com/files/PLC\\_SCADA\\_Project\\_Example\\_2.zip](http://advanceddiplomastage4d.zoomshare.com/files/PLC_SCADA_Project_Example_2.zip)

**PLC\_SCADA\_Project\_Example\_3.zip**

[http://advanceddiplomastage4d.zoomshare.com/files/PLC\\_SCADA\\_Project\\_Example\\_3.zip](http://advanceddiplomastage4d.zoomshare.com/files/PLC_SCADA_Project_Example_3.zip)

**Process\_Control\_Equipment\_Setup\_1.zip**

[http://advanceddiplomastage4d.zoomshare.com/files/Process\\_Control\\_Equipment\\_Setup\\_1.zip](http://advanceddiplomastage4d.zoomshare.com/files/Process_Control_Equipment_Setup_1.zip)

**Process\_Control\_Equipment\_Setup\_2.zip**

[http://advanceddiplomastage4d.zoomshare.com/files/Process\\_Control\\_Equipment\\_Setup\\_2.zip](http://advanceddiplomastage4d.zoomshare.com/files/Process_Control_Equipment_Setup_2.zip)

**SCADA\_PLC\_Project\_1.zip**

[http://advanceddiplomastage4d.zoomshare.com/files/SCADA\\_PLC\\_Project\\_1.zip](http://advanceddiplomastage4d.zoomshare.com/files/SCADA_PLC_Project_1.zip)

**SCADA\_PLC\_Project\_2.zip**

[http://advanceddiplomastage4d.zoomshare.com/files/SCADA\\_PLC\\_Project\\_2.zip](http://advanceddiplomastage4d.zoomshare.com/files/SCADA_PLC_Project_2.zip)

**SCADA\_PLC\_Project\_3.zip**

[http://advanceddiplomastage4d.zoomshare.com/files/SCADA\\_PLC\\_Project\\_3.zip](http://advanceddiplomastage4d.zoomshare.com/files/SCADA_PLC_Project_3.zip)

**SCADA\_PLC\_Project\_4.zip**

[http://advanceddiplomastage4d.zoomshare.com/files/SCADA\\_PLC\\_Project\\_4.zip](http://advanceddiplomastage4d.zoomshare.com/files/SCADA_PLC_Project_4.zip)

**SCADA\_PLC\_Project\_5.zip**

[http://advanceddiplomastage4d.zoomshare.com/files/SCADA\\_PLC\\_Project\\_5.zip](http://advanceddiplomastage4d.zoomshare.com/files/SCADA_PLC_Project_5.zip)

**(b) Method study**

Practical 1+2+3--- Take part in practical class

Practical 4 to 19 Digital--- Take part in practical class

Practical 20—PLC---6487 E.zip

**Equipments analysis**



You need to refer the following files

**PLC\_Application\_Assignment.zip**

[http://advanceddiplomastage4d.zoomshare.com/files/PLC\\_Application\\_Assignment.zip](http://advanceddiplomastage4d.zoomshare.com/files/PLC_Application_Assignment.zip)

**Control\_Circuit\_Boards.zip**

[http://advanceddiplomastage4d.zoomshare.com/files/Control\\_Circuit\\_Boards.zip](http://advanceddiplomastage4d.zoomshare.com/files/Control_Circuit_Boards.zip)

**PLC\_Hardware\_Notes\_1.zip**

[http://advanceddiplomastage4d.zoomshare.com/files/PLC\\_Hardware\\_Notes\\_1.zip](http://advanceddiplomastage4d.zoomshare.com/files/PLC_Hardware_Notes_1.zip)

**PLC\_Hardware\_Notes\_2.zip**

[http://advanceddiplomastage4d.zoomshare.com/files/PLC\\_Hardware\\_Notes\\_2.zip](http://advanceddiplomastage4d.zoomshare.com/files/PLC_Hardware_Notes_2.zip)

**PLC\_Hardware\_Notes\_3.zip**

[http://advanceddiplomastage4d.zoomshare.com/files/PLC\\_Hardware\\_Notes\\_3.zip](http://advanceddiplomastage4d.zoomshare.com/files/PLC_Hardware_Notes_3.zip)

**PLC\_Hardware\_Notes\_4.zip**

[http://advanceddiplomastage4d.zoomshare.com/files/PLC\\_Hardware\\_Notes\\_4.zip](http://advanceddiplomastage4d.zoomshare.com/files/PLC_Hardware_Notes_4.zip)

**PLC\_Hardware\_Notes\_5.zip**

[http://advanceddiplomastage4d.zoomshare.com/files/PLC\\_Hardware\\_Notes\\_5.zip](http://advanceddiplomastage4d.zoomshare.com/files/PLC_Hardware_Notes_5.zip)

**PLC\_Hardware\_Notes\_6.zip**

[http://advanceddiplomastage4d.zoomshare.com/files/PLC\\_Hardware\\_Notes\\_6.zip](http://advanceddiplomastage4d.zoomshare.com/files/PLC_Hardware_Notes_6.zip)

**SCADA\_PLC\_Project\_1.zip**

[http://advanceddiplomastage4d.zoomshare.com/files/SCADA\\_PLC\\_Project\\_1.zip](http://advanceddiplomastage4d.zoomshare.com/files/SCADA_PLC_Project_1.zip)

**SCADA\_PLC\_Project\_2.zip**

[http://advanceddiplomastage4d.zoomshare.com/files/SCADA\\_PLC\\_Project\\_2.zip](http://advanceddiplomastage4d.zoomshare.com/files/SCADA_PLC_Project_2.zip)

**SCADA\_PLC\_Project\_3.zip**

[http://advanceddiplomastage4d.zoomshare.com/files/SCADA\\_PLC\\_Project\\_3.zip](http://advanceddiplomastage4d.zoomshare.com/files/SCADA_PLC_Project_3.zip)

**SCADA\_PLC\_Project\_4.zip**

[http://advanceddiplomastage4d.zoomshare.com/files/SCADA\\_PLC\\_Project\\_4.zip](http://advanceddiplomastage4d.zoomshare.com/files/SCADA_PLC_Project_4.zip)

**SCADA\_PLC\_Project\_5.zip**

[http://advanceddiplomastage4d.zoomshare.com/files/SCADA\\_PLC\\_Project\\_5.zip](http://advanceddiplomastage4d.zoomshare.com/files/SCADA_PLC_Project_5.zip)

**[PLC\\_Triology\\_Advanced\\_Programs.zip](#)**

[http://advanceddiplomastage4d.zoomshare.com/files/PLC\\_Triology\\_Advanced\\_Programs.zip](http://advanceddiplomastage4d.zoomshare.com/files/PLC_Triology_Advanced_Programs.zip)

**[PLC\\_SCADA\\_Project\\_Example\\_1.zip](#)**

[http://advanceddiplomastage4d.zoomshare.com/files/PLC\\_SCADA\\_Project\\_Example\\_1.zip](http://advanceddiplomastage4d.zoomshare.com/files/PLC_SCADA_Project_Example_1.zip)

**[PLC\\_SCADA\\_Project\\_Example\\_2.zip](#)**

[http://advanceddiplomastage4d.zoomshare.com/files/PLC\\_SCADA\\_Project\\_Example\\_2.zip](http://advanceddiplomastage4d.zoomshare.com/files/PLC_SCADA_Project_Example_2.zip)

**[PLC\\_SCADA\\_Project\\_Example\\_3.zip](#)**

[http://advanceddiplomastage4d.zoomshare.com/files/PLC\\_SCADA\\_Project\\_Example\\_3.zip](http://advanceddiplomastage4d.zoomshare.com/files/PLC_SCADA_Project_Example_3.zip)

**[Process\\_Control\\_Equipment\\_Setup\\_1.zip](#)**

[http://advanceddiplomastage4d.zoomshare.com/files/Process\\_Control\\_Equipment\\_Setup\\_1.zip](http://advanceddiplomastage4d.zoomshare.com/files/Process_Control_Equipment_Setup_1.zip)

**[Process\\_Control\\_Equipment\\_Setup\\_2.zip](#)**

**[http://advanceddiplomastage4d.zoomshare.com/files/Process\\_Control\\_Equipment\\_Setup\\_2.zip](http://advanceddiplomastage4d.zoomshare.com/files/Process_Control_Equipment_Setup_2.zip)**

Digital Practical

**<http://uploading.com/files/3d324765/Digital%2BPractical.zip/>**

List of equipments used in practical (Page number of equipment + Name of equipment)+  
Method analysis

Circuit connection by using above equipments (Refer example diagram)

## **PART (8) Study area(5)Renewable Energy Practicals**

Take part in face to face class

## Renewable Energy-K032+K025+K035+K041 Work Performance Projects

<http://uploading.com/files/fd651ece/Renewable%2BEnergy-K032%2BK025%2BK035%2BK041%2BWork%2BPerformance%2BProjects.zip/>

Activity (1)

(4) Use street directory and location of your home, answer the followings

(a) Orientation (b) How shading is constructed (c) How glasses are fitted (d) How heavy weight and light weight materials are allocated (e) Provide the idea how will you do to improve the comfort in summer and in winter.

Activity (2)

(7) Use daily weather broadcasting or thermometer from today to next two weeks, you record the followings and present the table

Day	Sunny	Cloudy	rain	Sun rise	Sun set	Temperature
1						
2						
Up to 14						

(8) Observe the behaviour of your family members on one Sunday and fill in the given chart. You divide the time and note the most activity done by your family member. Then fill the form and calculate the heat gain.

Family Member Number	6 AM TO 9 AM					9 AM TO 12					12 To 3 PM					3 PM TO 6 PM					Heat Gain
	S	W	L	M	H	S	W	L	M	H	S	W	L	M	H	S	W	L	M	H	
1																					
2																					
3 etc																					

S-Seating W- Walking L-Light work M-Medium work, H-Heavy work

(11) A mud brick wall has the following dimensions: Height 2.4 m, length 5m, thickness 300 mm, If two surfaces are 19 degree C and 11 degree C respectively, Calculate (a) rate of heat flow through the wall (b) the R value of the wall.

(14) Calculate U value for pitched metal deck roof with reflective foil insulation and raked ceiling with R 1.5 bulk insulation.

(15) Calculate U value for a pitched and vented tile roof with reflective foil laminate under the tiles.

(16) Explain how the orientation of the windows and type of glass affects the heat transfer into the building.

(17) Calculate net gain or loss of heat through a month for north facing single glass window for January & July in Sydney. The window is 0.9 m height and 0.2 m from the bottom of the eaves which are 0.6m wide. Assume for window that 90% of it is glass. Transmittance is 0.76 and U value is 6.14

(23) Measure total wall area of your home, total windows area for all glasses

Find total glass area at the North side of the wall. Does it agree with the standard for allocating

The total % of north facing glass.

(28) Calculate total heat gain for the following building.

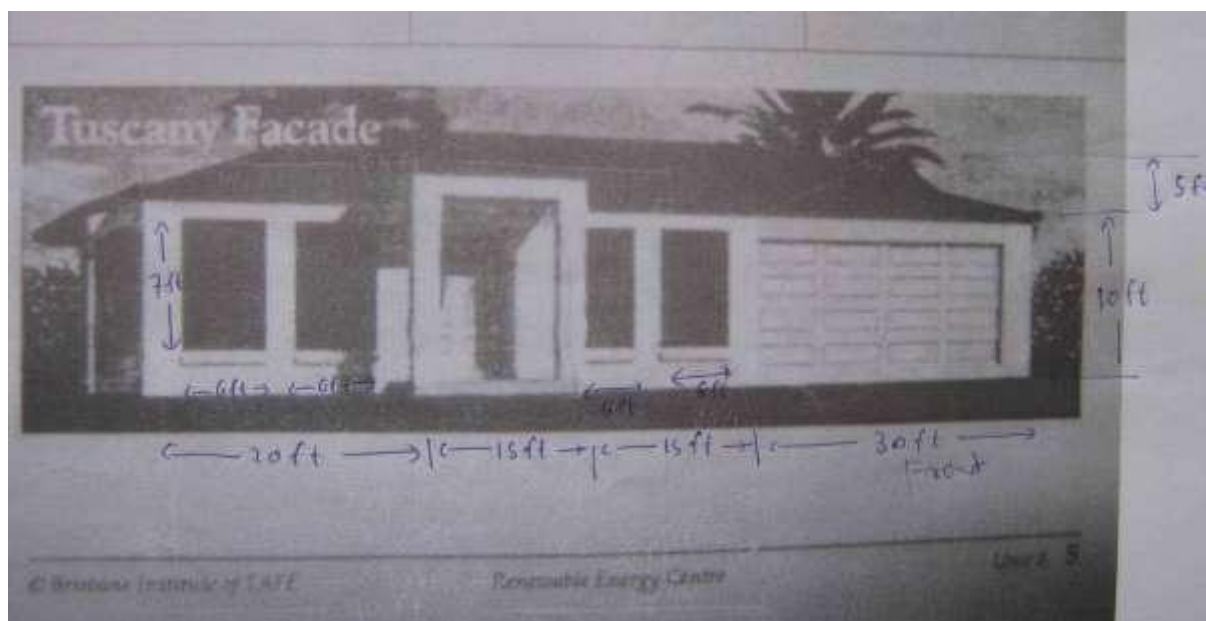
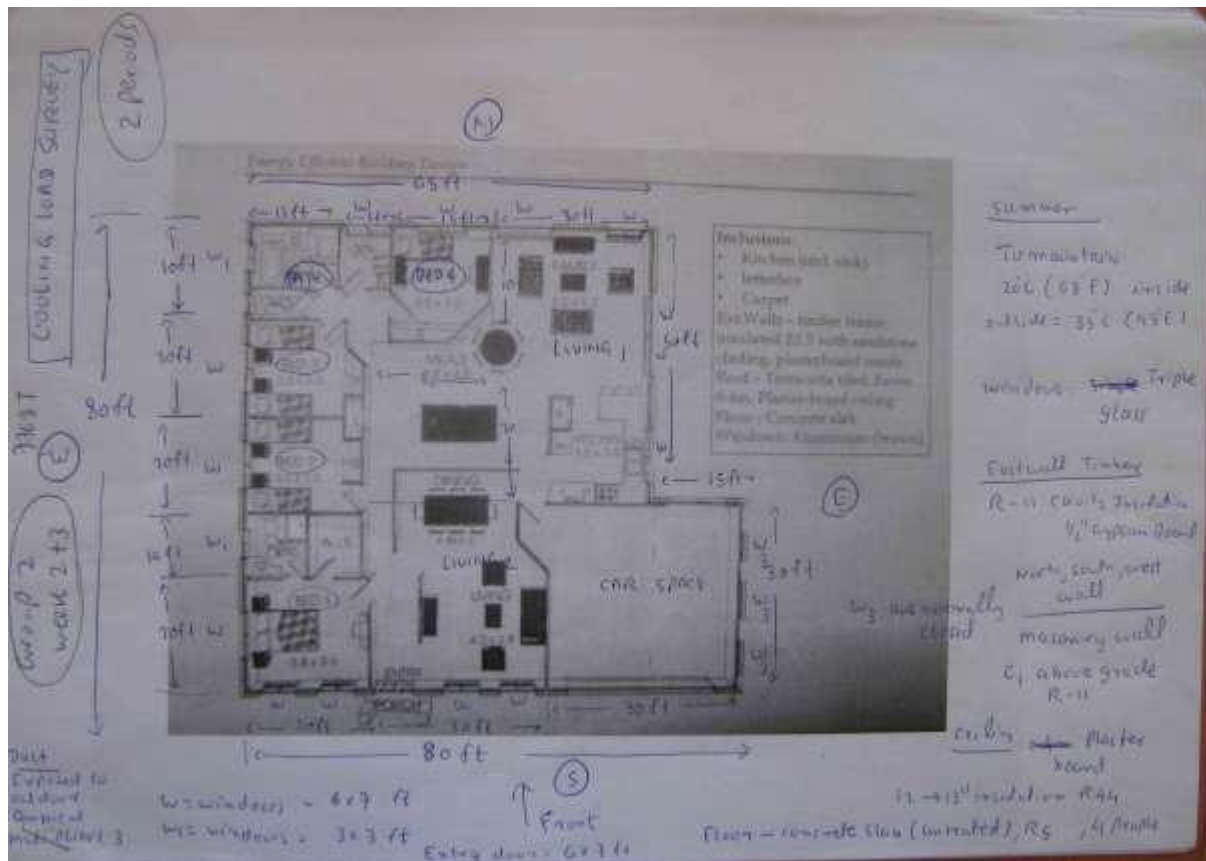

(29) Calculate total heat loss by conduction for a simple one room house in Melbourne during the months of January & July.

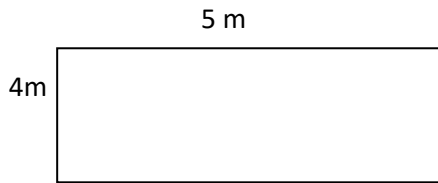

Roof: 15 Degree. Thickness of tile 19 mm.  $K = 0.81$ . Plaster board 13 mm,  $K = 0.17$ .

Wall Aerated concrete 200 mm thick.

Outside air ( $R_{out}$ )  $0.12 \text{ m}^2 \text{ K/W}$  Inside air ( $R_{in}$ )  $0.04 \text{ m}^2 \text{ K/W}$

The house has  $1 \text{ m}^2$  window on each wall, average ceiling, no open fire space and weather stripping at the bottom of external doors. The house is  $4 \text{ m} \times 5 \text{ m}$  with  $2.4 \text{ m}$  ceiling height. The windows are single glazed.  $U_1$  and  $U_2$  are  $U_{summer}$  and  $U_{winter}$  respectively.

The roof is a double pitched and vented tile roof with reflective foil laminate under the tile. Floor is carpet on a concrete slab on ground.

(30) In the above problem, calculate infiltration heat loss/ gain in this building. (Timber window, average ceiling, no open fire place).

$$Q_v = A_c V (T_i - T_a) N \times 0.0286$$

(30) Calculate the heating required over a year (base temperature 15 degree) for the one storey house with the following roofs and walls in the winter.

Roof

-New galvanized iron ( metal deck)

-10m x 9m & 22.5 degree slope.

-Aligned East-west

- with R 1.5 foil backed insulation

-Plastered board on ceiling joists

East wall	South wall	Floor
-Unglazed red brick veneer foil insulated	-Unglazed red brick veneer foil insulated	Cork tiles on concrete slab on the ground
9.4 m x 2.5 m	10 m x 25 m	10 m x 9.4 m
One window 1 m x 0.8 m	Two windows 1 m x 0.7 m each	

All windows are single glazed. Assume ceiling height is 2.5 m

The building has timber windows , average ceiling, no open fire space, weather stripping at the bottom of external doors.

The house is located in Kalgoorlie, western Australia.

(31)(a) Calculate heat gain per day from the customers in a 150 m<sup>2</sup> gym, If the gym capacity is 50 customers and the gym is full between 6 am to 8 am and 5 pm to 8:30 pm. At all other times, it is 30% full on average.

(b) Calculate heating contributions from all the appliances in a communal house containing 8 people. The house has one electric hot water system for two bath rooms, 6 bed rooms and one all electric kitchen. One TV, seven music systems, two computers and twenty lights. Assume that the house uses 32 kwh per day and the hot water is 45% of the load. The cooker consumes 20% of the load and 25% of heat generated by cooker is vented outside by the range hood.

(c) In above (b) would it make any difference if the water heater was located outside the building?

(d) What would be the heat gain per month if the cooker in (b) uses bottle gas (Gas is 45MJ/Kg and the house uses 0.5 kg/ day)?

(e) The table below lists the power consumption of the appliances used in the house and the hours per day for which they are used. Calculate heat gain from appliances per month.

Appliance	Power (watt)	Daily usage per appliance (hr)
TV	40	12
Music system	40	4
Computer	120	12
Printer	20	1
Lights	60	2

(32) A 4000 sq ft retail store near Tucson, Arizona has been calculated to have sensible heat gain of 100,000 Btuh at summer design condition. (105 DB, 66 WB for this location). Calculate heat removed and air flow rate indoor.

(33)

Based on above, 4000 sq ft needs 13227 cfm air .Calculate air requirement for the following home and allocate the layout of the duct. 66% of air is applied.

### **(a) Literature study**

K025+4291K

UEENEEK025		Solve basic problems in photovoltaic energy apparatus
4291K	NUER01	Intro to renewable energy technologies

**K025\_Note\_1**

[http://powerclass.zoomshare.com/files/K025\\_Note\\_1.zip](http://powerclass.zoomshare.com/files/K025_Note_1.zip)

**K025\_Note\_2**

[http://powerclass.zoomshare.com/files/K025\\_Note\\_2.zip](http://powerclass.zoomshare.com/files/K025_Note_2.zip)

K025 Resources

**ELV\_Accessories\_-\_SPS\_Components**

[http://powersemester2.zoomshare.com/files/ELV\\_Accessories\\_-\\_SPS\\_Components.pps](http://powersemester2.zoomshare.com/files/ELV_Accessories_-_SPS_Components.pps)

**ELV\_Cable\_termination**

[http://powersemester2.zoomshare.com/files/ELV\\_Cable\\_termination.pps](http://powersemester2.zoomshare.com/files/ELV_Cable_termination.pps)

**PV\_System\_installation\_Overview\_-\_PV\_Power\_Systems**

[http://powersemester2.zoomshare.com/files/PV\\_System\\_installation\\_Overview\\_-\\_PV\\_Power\\_Systems.pps](http://powersemester2.zoomshare.com/files/PV_System_installation_Overview_-_PV_Power_Systems.pps)

**SPS\_Components**

[http://powersemester2.zoomshare.com/files/SPS\\_Components.pps](http://powersemester2.zoomshare.com/files/SPS_Components.pps)

**System\_Installation\_Examples\_-\_NUER02\_version**

[http://powersemester2.zoomshare.com/files/System\\_Installation\\_Examples\\_-\\_NUER02\\_version.pps](http://powersemester2.zoomshare.com/files/System_Installation_Examples_-_NUER02_version.pps)

**PVSoftware**

<http://powersemester2.zoomshare.com/files/PVSoftware.zip>

**K041+E047+7768T**

UEENEEK041		Develop strategies for effective energy reduction in buildings
UEENEEE047		Identify building techniques, methods and materials used in electrotechnology work activities
7768T	EB151	Air conditioning system design

**K041\_Building\_Design\_1**

[http://powerteaching.zoomshare.com/files/K041\\_Building\\_Design\\_1.zip](http://powerteaching.zoomshare.com/files/K041_Building_Design_1.zip)

**K041\_Building\_Design\_2**

[http://powerteaching.zoomshare.com/files/K041\\_Building\\_Design\\_2.zip](http://powerteaching.zoomshare.com/files/K041_Building_Design_2.zip)

**K041Airconditioning**

<http://powerteaching.zoomshare.com/files/K041Airconditioning.zip>

**K041Energy\_Management\_Textbook**

[http://powerteaching.zoomshare.com/files/K041Energy\\_Management\\_Textbook.zip](http://powerteaching.zoomshare.com/files/K041Energy_Management_Textbook.zip)

### **K041 Text book**

**K041Textbook1.zip**

<http://15000.zoomshare.com/files/K041Textbook1.zip>

**K041Textbook2.zip**

<http://15000.zoomshare.com/files/K041Textbook2.zip>

**K041Textbook3.zip**

<http://15000.zoomshare.com/files/K041Textbook3.zip>

### **K035**

UEENEEK035C		Design grid connected power supply systems
-------------	--	--

### **K035Inverter**

<http://powersemester1.zoomshare.com/files/K035Inverter.zip>

### **K035PV\_Inverter**

[http://powersemester1.zoomshare.com/files/K035PV\\_Inverter.zip](http://powersemester1.zoomshare.com/files/K035PV_Inverter.zip)

### **(b) Method study**

Practical K 035 Pulse Width Modulation

Solar electrical connection

Renewable Energy-K032+K025+K035+K041 Work Performance Projects

<http://uploading.com/files/fd651ece/Renewable%2BEnergy-K032%2BK025%2BK035%2BK041%2BWork%2BPerformance%2BProjects.zip/>

Renewable energy-PV installation

<http://uploading.com/files/7d79368a/Renewable%2BEnergy.zip/>

### **PV\_System\_installation\_Overview\_-\_PV\_Power\_Systems**

[http://powersemester2.zoomshare.com/files/PV\\_System\\_installation\\_Overview\\_-\\_PV\\_Power\\_Systems.pps](http://powersemester2.zoomshare.com/files/PV_System_installation_Overview_-_PV_Power_Systems.pps)

### **SPS\_Components**

[http://powersemester2.zoomshare.com/files/SPS\\_Components.pps](http://powersemester2.zoomshare.com/files/SPS_Components.pps)



**System\_Installation\_Examples\_-\_NUER02\_version**

[http://powersemester2.zoomshare.com/files/System\\_Installation\\_Examples\\_-\\_NUER02\\_version.pps](http://powersemester2.zoomshare.com/files/System_Installation_Examples_-_NUER02_version.pps)

**(d) Result submission****(e) Reference****(f) OHS****PART (9) Study area(6)Electrical Fundamental Practicals**

Electrical Circuit Fundamental-E029+G002+G048+G049+E025-Work Performance Project

<http://uploading.com/files/8697m628/Electrical%2BCircuit%2BFundamental-E029%2BG002%2BG048%2BG049%2BE025-Work%2BPerformance%2BProject.zip/>

List of practicals

1. E029 practical 2/Practical E029 –Power factor measurement
2. E029 practical 2/Practical E029-Three phase balanced and unbalanced load
3. E029 practical 2/Practical E029-Maximum power transfer theorem
4. E029 practical 2/Practical E029-Series RLC circuit
5. E029 practical 2/Practical E029-Superposition theorem
6. Practical G049-Three phase power measurement
7. Practical G002+G049 –AC/DC Comparison
8. Practical G002+G049-Star delta load
9. Practical G048-Maximum power transfer theorem
10. Reactive power

**(a) Literature study****G001+G002**

UEENEEG002		Solve problems in single and three phase low voltage circuits
7793A	NE160	Electrical principles 1
7793B	NE161	Electrical principles 2

**G002**

<http://powerclass.zoomshare.com/files/G002.zip>

[G047+7762AH+4269T](#)

UEENEEG047		Provide computational solutions to power engineering problems
7762AH	EA157	Power systems fundamentals
4269T	EB164	Transmission lines 1

### **G047\_4269T\_7762AH.zip**

[http://powerclass.zoomshare.com/files/G047\\_4269T\\_7762AH.zip](http://powerclass.zoomshare.com/files/G047_4269T_7762AH.zip)

### **G048+7769AC**

UEENEEG048		Solve problems in complex multiple path power circuits
7769AC	EB162	Circuit analysis 1

### **G048\_7769AC**

[http://powerclass.zoomshare.com/files/G048\\_7769AC.zip](http://powerclass.zoomshare.com/files/G048_7769AC.zip)

### **Notes for assignment/ tutorials**

### **G048\_Full\_Part\_1.zip**

[http://advanceddiplomastage4e.zoomshare.com/files/G048\\_Full\\_Part\\_1.zip](http://advanceddiplomastage4e.zoomshare.com/files/G048_Full_Part_1.zip)

### **G048Part2.zip**

<http://advanceddiplomastage4f.zoomshare.com/files/G048Part2.zip>

### **G049+7762AB+7761M**

UEENEEG049		Solve problems in complex polyphase power circuits
7762AB	EA155	Fault calculations

### **G049\_7762AB\_7761M\_Notes**

[http://powersemester1.zoomshare.com/files/G049\\_7762AB\\_7761M\\_Notes.doc](http://powersemester1.zoomshare.com/files/G049_7762AB_7761M_Notes.doc)

### **E025+4269S**

UEENEE025		Solve problems in complex multiple path circuits
4269S	EB163	Circuit analysis 2

### **E025\_Circuits\_1**

[http://powerclass.zoomshare.com/files/E025\\_Circuits\\_1.zip](http://powerclass.zoomshare.com/files/E025_Circuits_1.zip)

### **E025\_Circuits\_2**

[http://powerclass.zoomshare.com/files/E025\\_Circuits\\_2.zip](http://powerclass.zoomshare.com/files/E025_Circuits_2.zip)

**(b) Method study**

Refer the file included in Electrical Circuit Fundamental-E029+G002+G048+G049+E025-Work Performance Project

<http://uploading.com/files/8697m628/Electrical%2BCircuit%2BFundamental-E029%2BG002%2BG048%2BG049%2BE025-Work%2BPerformance%2BProject.zip/>

+

General Practical Reference for all power diploma units-G069+G070

<http://uploading.com/files/2m693269/General%2BPractical%2BReference%2Bfor%2B all%2Bpower%2Bdiploma%2Bunits-G069%2BG070.zip/>

**Method analysis**

You need to find the relevant practical instructions from

**Practical1Instruction**

<http://powersemester2.zoomshare.com/files/Practical1Instruction.zi>

**Practical3-2009**

<http://powersemester2.zoomshare.com/files/Practical3-2009.zip>

**Practical\_1-2009Instruction**

[http://powersemester3.zoomshare.com/files/Practical\\_1-2009Instruction.zip](http://powersemester3.zoomshare.com/files/Practical_1-2009Instruction.zip)

NIL

**Practical\_2-2009Instruction1**

[http://powersemester3.zoomshare.com/files/Practical\\_2-2009Instruction1.zip](http://powersemester3.zoomshare.com/files/Practical_2-2009Instruction1.zip)

Page 1,2,3,4,5,6,7,8,9,10,11,15,16

**Practical\_2-2009Instruction2**

[http://powersemester3.zoomshare.com/files/Practical\\_2-2009Instruction2.zip](http://powersemester3.zoomshare.com/files/Practical_2-2009Instruction2.zip)

Page 36,37,38

**Practical\_3\_Instruction**

[http://powersemester3.zoomshare.com/files/Practical\\_3\\_Instruction\\_.zip](http://powersemester3.zoomshare.com/files/Practical_3_Instruction_.zip)

Page 10,11,12,14,15,19,20,21,22,23,24

**(c) Analysis of devices**

Refer the file included in Electrical Circuit Fundamental-E029+G002+G048+G049+E025-Work Performance Project

<http://uploading.com/files/8697m628/Electrical%2BCircuit%2BFundamental-E029%2BG002%2BG048%2BG049%2BE025-Work%2BPerformance%2BProject.zip/>

+

General Practical Reference for all power diploma units-G069+G070

<http://uploading.com/files/2m693269/General%2BPractical%2BReference%2Bfor%2Ball%2Bpower%2Bdiploma%2Bunits-G069%2BG070.zip/>

**Equipments analysis**

You need to refer the following files

**Practical1-2010Part1**

<http://powersemester2.zoomshare.com/files/Practical1-2010Part1.zip>

Nil

**Practical1-2010Part2**

<http://powersemester2.zoomshare.com/files/Practical1-2010Part2.zip>

Nil

**Practical1-2010Part3**

<http://powersemester2.zoomshare.com/files/Practical1-2010Part3.zip>

Page 19,20,21,32,33,34,35,36,37,38,39,40,41,42,49

**Equipments****Practical1-2009Equipmen1a**

<http://powersemester2.zoomshare.com/files/Practical1-2009Equipmen1a.zip>

Page 18,19,20,21,22,26,29

**Practical1-2009Equipmen1b**

<http://powersemester2.zoomshare.com/files/Practical1-2009Equipmen1b.zip>

Nil

**Practical1-2009Equipment2a**

<http://powersemester2.zoomshare.com/files/Practical1-2009Equipment2a.zip>

Page 5

### **Practical1-2009Equipment2b**

Nil

<http://powersemester2.zoomshare.com/files/Practical1-2009Equipment2b.zip>

### **Practical3-2009**

<http://powersemester2.zoomshare.com/files/Practical3-2009.zip>

Page 62,63,64,67,68,73,74,75,76,77

List of equipments used in practical (Page number of equipment + Name of equipment)+  
Method analysis

Circuit connection by using above equipments (Refer example diagram)

#### **(d) Data analysis**

[http://powersemester2.zoomshare.com/files/Lab\\_Instruction\\_data\\_1.zip](http://powersemester2.zoomshare.com/files/Lab_Instruction_data_1.zip)

<http://powersemester2.zoomshare.com/files/Practical1-2010Part1.zip>

<http://powersemester2.zoomshare.com/files/Practical1-2010Part2.zip>

<http://powersemester2.zoomshare.com/files/Practical1-2010Part3.zip>

#### **Lab\_Instruction\_data\_1**

[http://powersemester2.zoomshare.com/files/Lab\\_Instruction\\_data\\_1.zip](http://powersemester2.zoomshare.com/files/Lab_Instruction_data_1.zip)

#### **Data**

##### **Lab\_Data\_1**

[http://powersemester2.zoomshare.com/files/Lab\\_Data\\_1.zip](http://powersemester2.zoomshare.com/files/Lab_Data_1.zip)

##### **Lab\_Data\_2**

[http://powersemester2.zoomshare.com/files/Lab\\_Data\\_2.zip](http://powersemester2.zoomshare.com/files/Lab_Data_2.zip)

##### **Lab\_Data\_3**

[http://powersemester2.zoomshare.com/files/Lab\\_Data\\_3.zip](http://powersemester2.zoomshare.com/files/Lab_Data_3.zip)













