

Topic Skills Practice Cover Sheet

Unit Name:	UEEEL0020 Solve problems in low voltage a.c. circuits
Topic Title:	Power Factor Improvement

Skill Practice Number:	8.2.2
Skill Practice Name:	Power Factor Improvement Method

Student Name:	
Student ID:	
College/Campus:	
Group:	

Results	
Planning:	
Carryout:	
Completion:	
Overall Results:	
Comments:	

Topic Skills Practice 8.2.2

UEEEL0020 Solve problems in low voltage a.c. circuits

Topic 8. Power Factor Improvement

Skills Practice 8.2.2: Power Factor Improvement Method

Task:

To examine power factor improvement methods using static capacitors on a single phase motor circuit.

Objectives:

At the completion of this skills practice, you should be able to:

- Connect up a single phase motor and a capacitor bank used for power factor improvement.
- Demonstrate that the overall power factor of an inductive circuit can be improved by the addition of capacitors in parallel with the circuit.
- Determine the capacitance of a capacitor to produce unity power factor by: experiment; and calculation.
- Construct a power triangle to calculate the required reactive power (VAr) to produce a power factor of 0.8 lagging, 0.9 lagging and 0.95 lagging.

Topic Skills Practice 8.2.2

1. Planning the Skills Practice

1.1 Equipment

- ELV a.c. supply
- Two multimeters
- One wattmeter

1.2 Suggested Materials

- Single-phase induction motor
- Capacitor bank

1.3 Miscellaneous Items

- Connection leads
- PPE
- Pens/pencils
- Ruler



1.4 Risk Assessment

Risk assessment procedure:

- Identify any hazards that may exist with this skills practice below
- List the supervision level you will be working under - Direct (D), General (G) or Broad (B)
- List the risk classification – High Risk (H), Medium Risk (M) or Low Risk (L)
- List the control measures required for each identified hazard that you need to implement.

Hazard/s Identified	Supervision Level (D, G or B)	Risk Classification (H, M or L)	Control Measure/s
Over voltage applied to motor	G	M	Use 24/42 V supply and transformer to provide motor operation voltage 40 V
Wrong connection of current coil of watt meter causing short circuit	G	M	Appropriately follow the circuit diagram of watt meter
Motor terminal to ground touching or insulation failure causing short circuit	D	H	Motor insulation resistance and ground fault needs to be assessed.

Topic Skills Practice 8.2.2

	 Feedback Have your teacher/trainer check your risk assessment	Teacher/Trainer Initials and Date 	
---	--	--	---

2. Carrying Out the Skills Practice

2.1 Circuit Connection and Measurements

2.1.1 Connect up the circuit as shown in Figure 1 below:

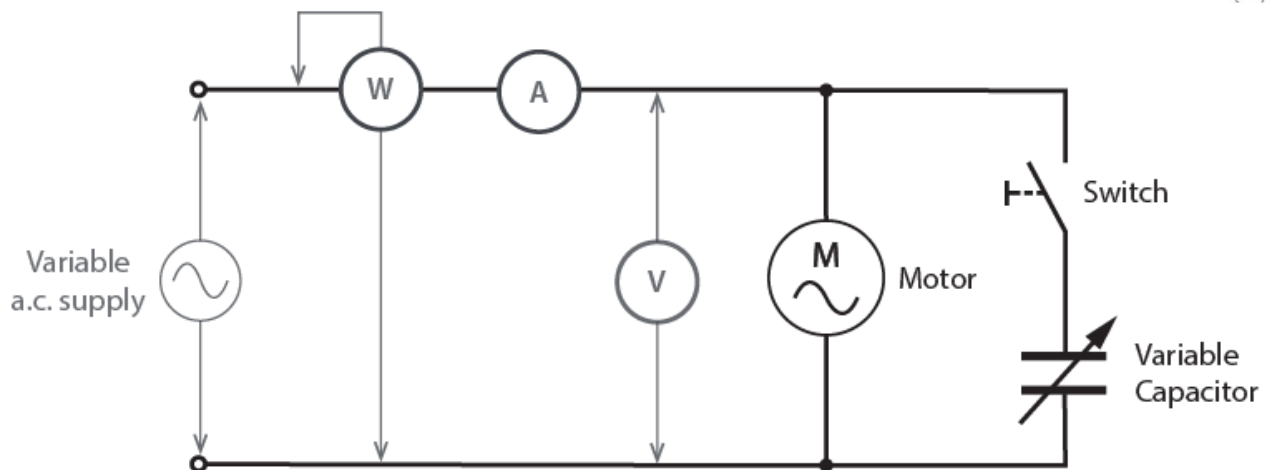
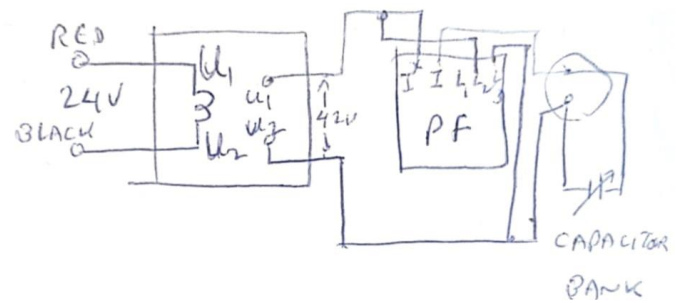

Figure 1

2.1.2 Make sure the capacitor switch is open and turn on the supply to the motor. Measure the input power, current and voltage and record these values in Table 1.

Supply voltage , <i>V</i> volts	Current, <i>I</i> amperes	Input power, <i>P</i> Watts
42	0.1	0.368

Table 1

A T PF = 0.9 V

Topic Skills Practice 8.2.2

2.1.3 Turn off the supply and set the capacitor bank to a value specified by your teacher/trainer.

2.1.4 Close the switch to connect the capacitor in parallel with the motor and measure the supply voltage, current and input power and record in Table 2.

2.1.5 Repeat step 3 and 4 for each of the capacitor values specified by your teacher/trainer. Record your results in table 2 on the following page.

P.F values are directly read

Capacitance C μF	Supply Voltage Volts	Current I Amperes	Supply Voltage Volts	Power factor p.f.	Lead or lag
16				0.55	Lag
32				0.6	Lag
30				0.57	Lag
92				0.92	Lag
48				0.7	Lag



Table 2

2.1.6 Calculate the power factor for each value of capacitance and record in Table 2. Indicate if the power factor is leading or lagging.

$$\text{Power factor} = \frac{\text{True power}}{\text{Apparent power}} = \frac{\text{Wattmeter reading}}{\text{Voltmeter xammeter reading}}$$

P.F values are directly read from meter

Topic Skills Practice 8.2.2

	 Feedback	Have your teacher/trainer check your work	Teacher/Trainer Initials and Date	

3. Completing the Skills Practice

3.1 Skills Practice Review and Observations

3.1.1 Draw the graphs of current and power factor versus capacitance on the same set of axes. (Use Table 2 values).

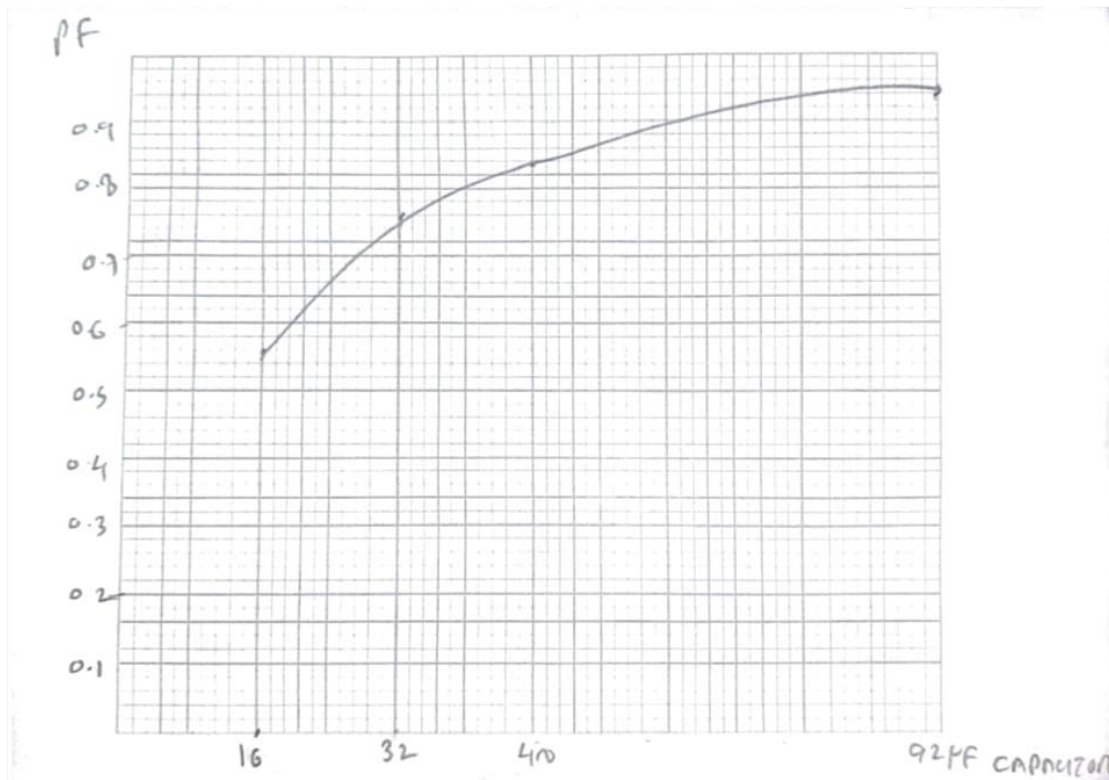

Calculate the capacitance of the capacitor required to produce unity p.f. Show your' working below.

$$\begin{aligned} \text{AT } \text{PF} &= 0.92, \cos \phi = 0.92, \phi = \cos^{-1} 0.92 = 23^\circ \\ \text{REACTIVE POWER} &= VI \tan \phi = 24 \times 0.1 \tan 23^\circ = 1.66 \text{ VAR} \\ I^2 \times X_C &= 1.66 \quad (I = 0.1 \text{ A}) \\ X_C &= \frac{1.66}{(0.1)^2} \Rightarrow X_C = \sqrt{166} = 166 \text{ VAR} \\ X_C &= \frac{1}{2\pi f C} \rightarrow C = \frac{1}{2\pi f X_C} = \frac{1}{2 \times 3.1416 \times 50 \times 166 \times 10^3} \\ &= 0.958 \text{ LAGGING} \end{aligned}$$

Topic Skills Practice 8.2.2

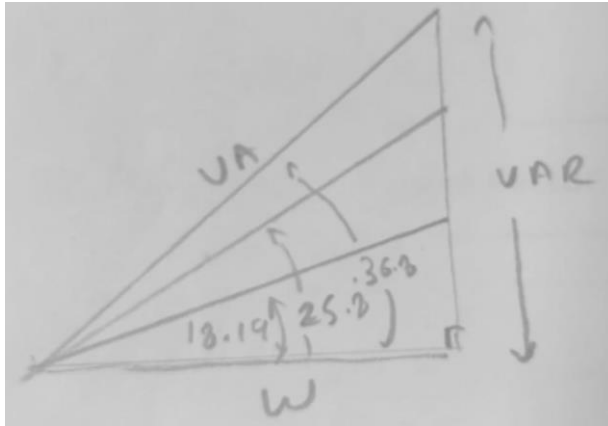

3.1.2 Draw the power triangles for the circuit when the power factor is:

- (a) 0.8 lagging 0.8 LAGGING, $\phi = \cos^{-1} 0.8 = 36.8$
- (b) 0.9 lagging 0.9 LAGGING, $\phi = \cos^{-1} 0.9 = 25.2$
- (c) 0.95 lagging 0.95 LAGGING, $\phi = \cos^{-1} 0.95 = 18.19$



3.1.3 Why do the supply authorities encourage consumers to have a high power factor for their installation?

At high power factor, it will draw less current so that line wires and switch gear sizes can be reduced to handle the current.

	 Feedback	Have your teacher/trainer check your answers	Teacher/Trainer Initials and Date	



Topic Skills Practice Cover Sheet

Unit Name:	UEEEL0020 Solve problems in low voltage a.c. circuits
Topic Title:	Three Phase Star Connections

Skill Practice Number:	10.2.1
Skill Practice Name:	Reversing three phase windings

Student Name:	
Student ID:	
College/Campus:	
Group:	

Results	
Planning:	
Carryout:	
Completion:	
Overall Results:	
Comments:	

Topic Skills Practice 10.2.1

UEEEL0020 Solve problems in low voltage a.c. circuits

Topic 10. Three Phase Star Connections

Skills Practice 10.2.1: Reversing three phase windings

Task:

To investigate the effects when a winding is reversed on a star connected 3 phase alternator.

Objectives:

At the completion of this skills practice, you should be able to:

- Connect up a 3 phase alternator.
- Examine the effects when one winding of a star connected alternator is reversed.

Topic Skills Practice 10.2.1

1. Planning the Skills Practice

1.1 Equipment

- ELV a.c. supply
- Three phase alternator
- Three phase squirrel cage induction motor
- Digital multimeter
- d.c. power supply

1.2 Suggested Materials

- Load bank
- Single pole switch
- Fuse panel

1.3 Miscellaneous Items

- Connection leads
- PPE
- Pens/pencils
- Ruler
- Calculator



1.4 Risk Assessment

Risk assessment procedure:

- Identify any hazards that may exist with this skills practice below
- List the supervision level you will be working under - Direct (D), General (G) or Broad (B)
- List the risk classification – High Risk (H), Medium Risk (M) or Low Risk (L)
- List the control measures required for each identified hazard that you need to implement.

Hazard/s Identified	Supervision Level (D, G or B)	Risk Classification (H, M or L)	Control Measure/s
Wrong connection of equipment Causing strong result	B	L	Check the proper terminal of equipment
Ground fault in equipment	G	M	Test the insulation resistance of equipment
Connecting transformer to dc supply causing fault	G	M	Transformer must be connected to Ac supply

Topic Skills Practice 10.2.1

	 Have your teacher/trainer check your risk assessment Feedback	Teacher/Trainer Initials and Date	
---	--	--------------------------------------	---

2. Carrying Out the Skills Practice

2.1.1 Connect up the three phase alternator circuit as shown in Figure 1.

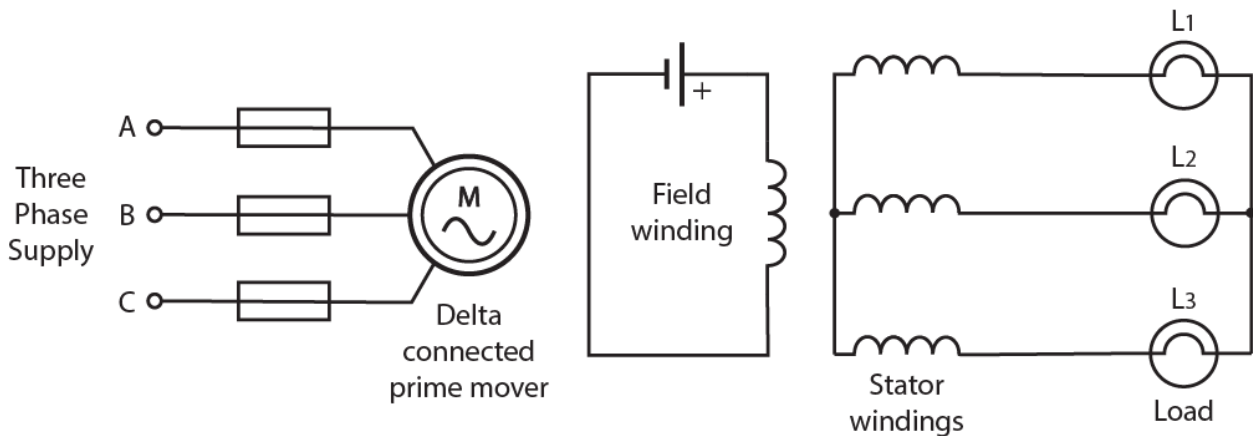





Figure 1

Instead of using alternator, 3 isolation transformer 42/24 V are utilized.

	 Have your teacher/trainer check your work Feedback	Teacher/Trainer Initials and Date	
---	---	--------------------------------------	---

2.1.2 Turn on the supply and adjust the d.c. power supply to the field winding to give you rated voltage from the alternator.

2.1.3 Measure each stator phase voltage and each load line voltage and record in Table 1.

Phase Voltages - volts		Line Voltages - volts	
VAN	13.25	VAB	22.8
VBN	13.11	VBC	22.57
VCN	12.9	VCA	22.58

Topic Skills Practice 10.2.1



Table 1 – Normal connections

2.1.4 Turn off the supply and reverse the “C” phase winding of the alternator.

2.1.5 Turn on the supply and measure the stator phase voltage and load line voltage and record in Table 2.

Phase Voltages - volts		Line Voltages - volts	
VAN	13.15	VAB	22.93
VBN	13.02	VBC	13.16
VCN	12.74	VCA	13.2

Table 2 – Reversed winding

	 Feedback Have your teacher/trainer check your work	Teacher/Trainer Initials and Date	
---	---	--------------------------------------	---

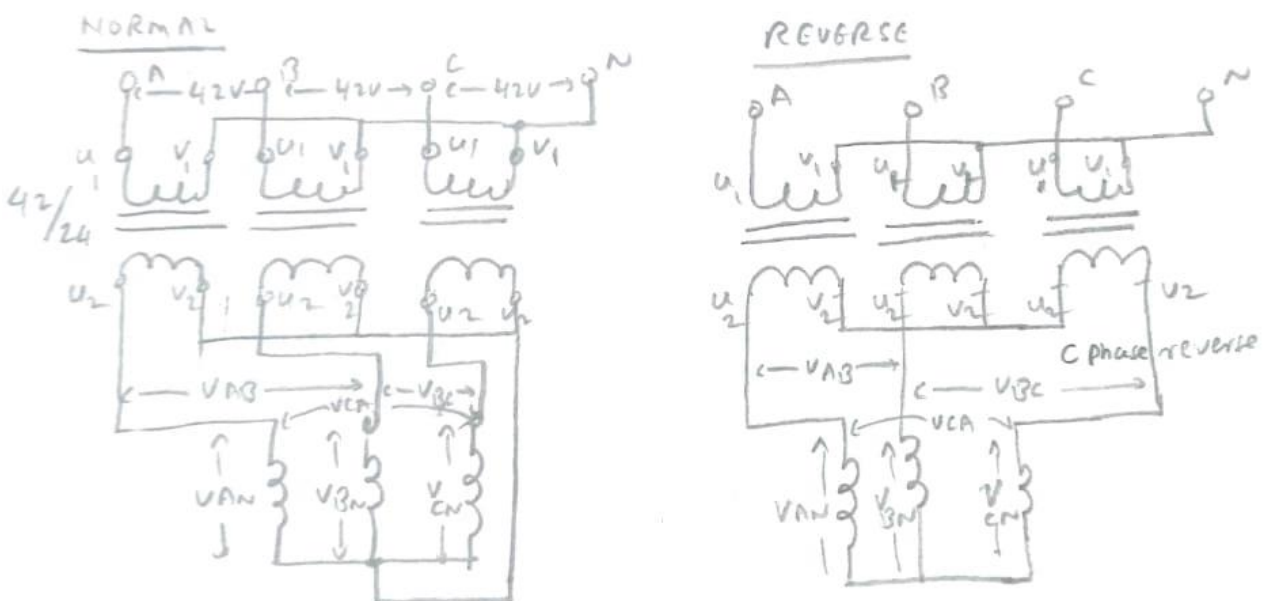

Topic Skills Practice 10.2.1

3. Completing the Skills Practice

3.1 Skills Practice Review and Observations

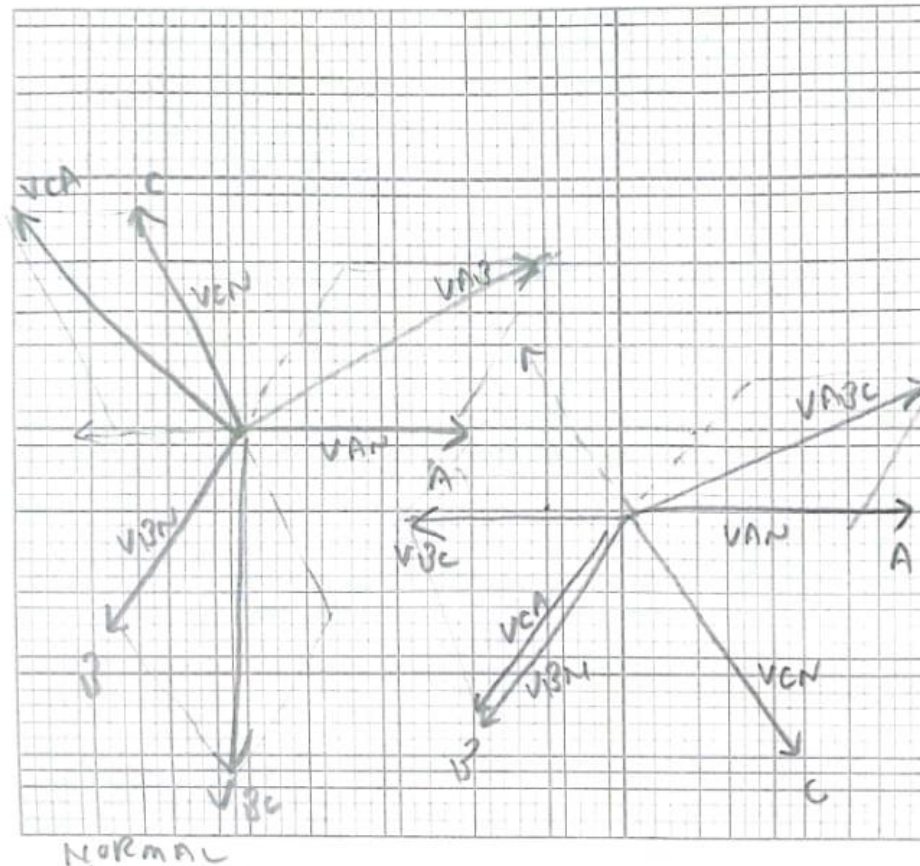

3.1.1 Disconnect, pack away your equipment and clean the work area as instructed by your teacher/trainer. Then complete the following questions based on your observations.

- Using your results from Table 1 and Table 2 draw the phasor diagrams for the phase and line voltages for normal connections and reversed winding connections for the alternator.



- What are the problems if one phase winding is reversed in a star connected alternator?

Two Line voltages will be equal to phase voltages causing unbalanced 3ϕ terminal voltage that will adversely impact on 3ϕ machines connected at the terminals.

	 Feedback	Have your teacher/trainer check your answers	Teacher/Trainer Initials and Date
			

Topic Skills Practice Cover Sheet

Unit Name:	UEEEL0020 Solve problems in low voltage a.c. circuits
Topic Title:	Energy and Power Requirements of a.c. Systems

Skill Practice Number:	13.3
Skill Practice Name:	Measure Three Phase Power

Student Name:	
Student ID:	
College/Campus:	
Group:	

Results	
Planning:	
Carryout:	
Completion:	
Overall Results:	
Comments:	

Topic Skills Practice 13.3

UEEEL0020 Solve problems in low voltage a.c. circuits

Topic 13. Energy and Power Requirements of a.c. Systems

Skills Practice 13.3: Measure Three Phase Power

Task:

To measure the power taken by a three phase motor when connected in star and delta.

Objectives:

At the completion of this skills practice, you should be able to:

- Connect up three phase loads and include wattmeters to measure the power
- Measure power in a balanced three phase circuit
- Use measured values of current, voltage and power to determine the power factor of a circuit
- Using manufacturers catalogues to select measurement equipment for a particular installation

Topic Skills Practice 13.3

1. Planning the Skills Practice

1.1 Equipment

- ELV a.c. supply
- Three phase induction motor
- Three pole switch
- Test equipment

1.2 Suggested Materials

- Two resistors $R_1 = R_2$
- Two wattmeters

1.3 Miscellaneous Items

- Connecting leads
- PPE
- Pens/pencils
- Manufacturer's catalogues – metering and power factor correction



1.4 Risk Assessment

1.4.1 Risk assessment procedure:

- Identify any hazards that may exist with this skills practice below
- List the supervision level you will be working under - Direct (D), General (G) or Broad (B)
- List the risk classification – High Risk (H), Medium Risk (M) or Low Risk (L)
- List the control measures required for each identified hazard that you need to implement.

Hazard/s Identified	Supervision Level (D, G or B)	Risk Classification (H, M or L)	Control Measure/s
Wrong connection of equipment causing wrong result	B	L	Check proper terminal of equipment
Ground fault in equipment	G	M	Test the insulation resistance of equipment
Connecting/motor transformer to dc supply causing fault	G	M	Transformer must be connected to Ac supply

Topic Skills Practice 13.3

	 Feedback	Have your teacher/trainer check your risk assessment	Teacher/Trainer Initials and Date	

2. Carrying Out the Skills Practice

2.1 Connect the Motor in Star

2.1.1 Connect the circuit shown below in Figure 1:

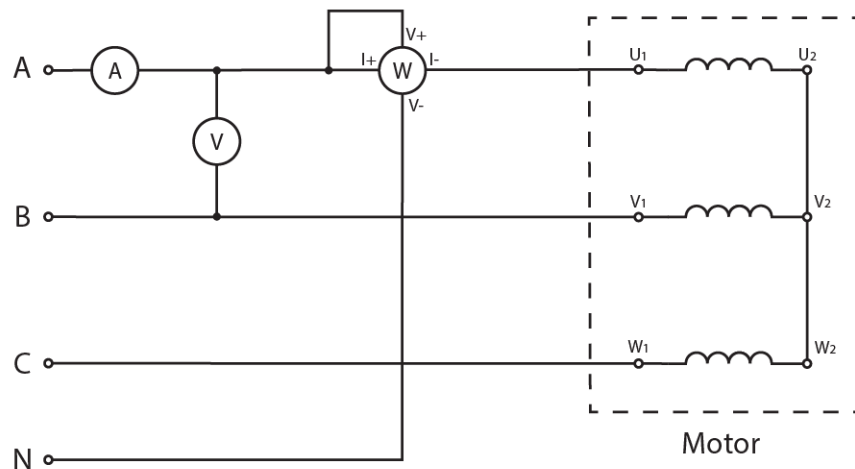





Figure 1

In this circuit:

- The motor windings are in star.
- The motor is connected to a three phase supply.
- A wattmeter and an ammeter are connected in A phase.
- A voltmeter is connected between A phase and B phase.

	 Feedback	Have your teacher/trainer check your work	Teacher/Trainer Initials and Date	

2.2 Evaluate Star Connected Circuit Parameters

2.2.1 Turn on the supply to the motor, and record in Table 1 the line current, line voltage and the power as indicated by the meters.

2.2.2 Turn off the supply and reposition the meters to measure the line current and power in phase B and the voltage between phase B and phase C.

Topic Skills Practice 13.3

2.2.3 Turn on the supply and record the meter readings as shown in Table 1 on the following page.

3 volt meter method is utilized to measure three phase power as below.

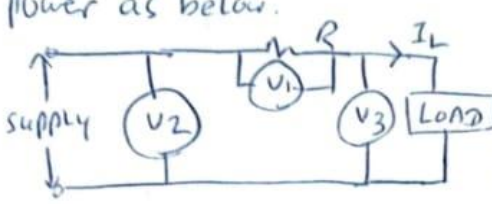

$$P_L = V_3 I_L \cos \phi$$

$$V_1 = I_L R$$

$$V_2 = \sqrt{V_1^2 + V_3^2 + 2V_1 V_3 \cos \phi}$$

$$V_2^2 = V_1^2 + V_3^2 + 2(I_L R) V_3 \cos \phi$$

$$V_2^2 = V_1^2 + V_3^2 + 2R P_L$$

Power factor = $\frac{\text{Real Power}}{\text{Apparent Power}}$

$$P_L = \frac{V_2^2 - V_1^2 - V_3^2}{2R}$$

3 ϕ power = $3P_L$

Apparent power = $\sqrt{3} V_L I_L$

CONNECTION

P₁

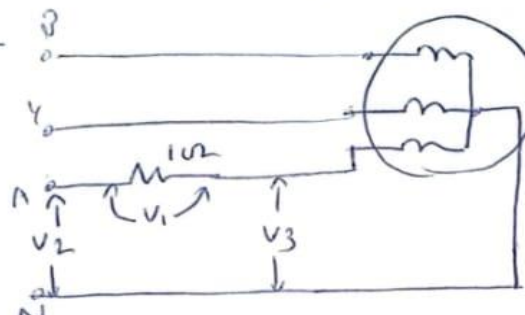

$V_2 = 24.55V$
 $V_1 = 0.335V$
 $V_3 = 24.37V$

$$P_1 = \frac{24.55^2 - 0.335^2 - 24.37^2}{2 \times 1}$$

= 4.34 W

$$I_1 = \frac{0.335V}{1\Omega} = 0.335A$$

P₂

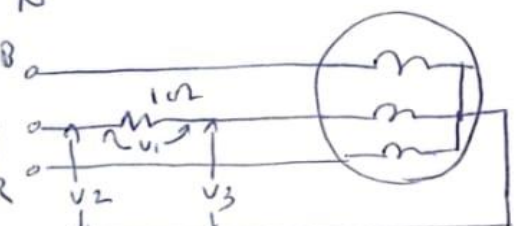

$V_2 = 24.3V$
 $V_1 = 0.304V$
 $V_3 = 24.18V$

$$P_2 = \frac{24.3^2 - 0.304^2 - 24.18^2}{2 \times 1}$$

= 2.86 W, $I_2 = \frac{0.304}{1} = 0.304A$

P₃

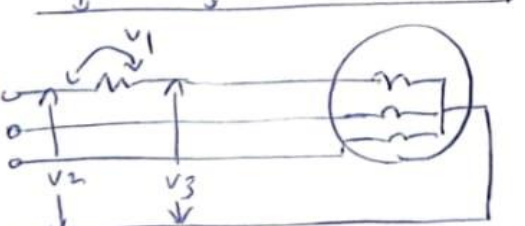

$V_2 = 24.4V$
 $V_3 = 24.32V$
 $V_1 = 0.328V$

$$P_3 = \frac{24.4^2 - 0.328^2 - 24.32^2}{2 \times 1} = 1.84W$$

$$I_3 = \frac{0.328}{1} = 0.328A$$

Total Power = $P_1 + P_2 + P_3 = 4.34 + 2.86 + 1.89 = 6.645W$

$I_{L \text{ Avg}} = \frac{0.335 + 0.328 + 0.304}{3} = 0.322A$

Topic Skills Practice 13.3

$$3\phi \text{ power} = \sqrt{3} E_L I_L \cos\phi$$

$$6.645 = 1.7321 \times 42.5 \times 0.322 \cos\phi$$

$$\cos\phi = \frac{6.645}{1.7321 \times 42.5 \times 0.322} = 0.28 \text{ LAGGING}$$

DELTA CONNECTION

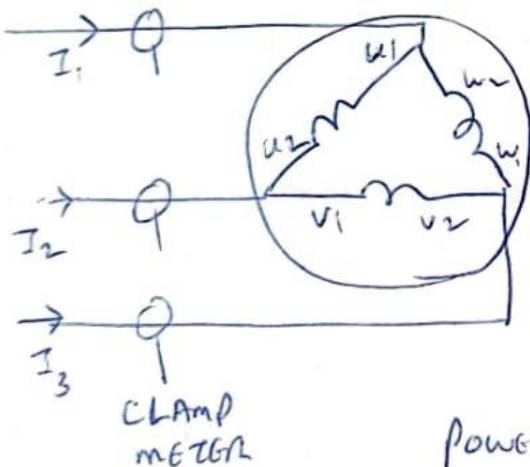

MOTOR POWER FACTOR
 $\cos\phi$ IS CONSTANT
 0.28

$$R-Y = 42.3V$$

$$Y-B = 42V$$

$$B-R = 42.3V$$

$$I_R = 0.8A, I_Y = 0.8A, I_B = 0.8A$$



$$\text{power} = \sqrt{3} E_L I_L \cos\phi$$

$$= 1.7321 \times 42.5 \times 0.8 \times 0.28$$

$$= 16.4W$$

2.2.4 Turn off the supply and reposition the meters to measure the line current and power in phase C and the voltage between phase C and phase A.

Table 1 – Measured Values – Star					
Line Current		Line Voltage		Power	
I_A	0.335 A	V_{A-B}	42.3 V	P_A	4.34 W
I_B	0.304 A	V_{B-C}	42 V	P_B	2.86 W
I_C	0.328 A	V_{A-C}	42.3 V	P_C	1.89 W

	 Have your teacher/trainer check your work Feedback	Teacher/Trainer Initials and Date	
---	---	--------------------------------------	---

Topic Skills Practice 13.3

2.3 Connect the Motor in Delta

2.3.1 Connect the circuit shown below in Figure 2:

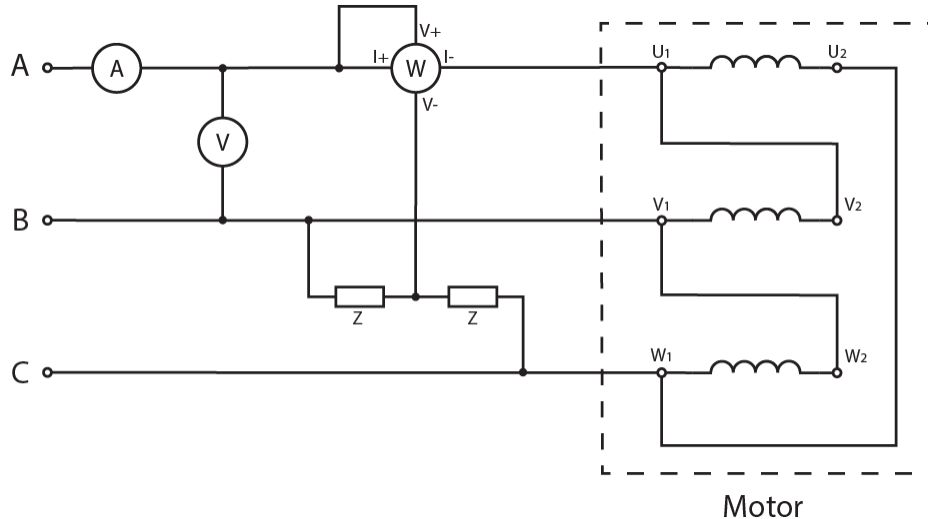

Figure 2

In this circuit:

- The motor windings are in delta.
- The motor is connected to a three phase supply.
- A wattmeter and an ammeter are connected in A phase.
- A voltmeter is connected between A phase and B phase.

2.3.2 Turn on the supply to the motor, and record the line current, line voltage and the power in Table 2.

2.3.3 Turn off the supply and reposition the meters to measure the line current and power in phase B and the voltage between phase B and phase C.

2.3.4 Turn on the supply and record the meter readings as shown in Table 2.

2.3.5 Turn off the supply and reposition the meters to measure the line current and power in phase C and the voltage between phase C and phase A.

Topic Skills Practice 13.3

2.3.6 Turn on the supply power and record the meter readings as shown in Table 2.

Table 2 – Measured Values – Delta					
Line Current		Line Voltage		Power	
I_A	0.8 A	V_{A-B}	42.3 V	P_A	5.47 W
I_B	0.8 A	V_{B-C}	42 V	P_B	5.43 W
I_C	0.8 A	V_{A-C}	42.3 V	P_C	5.47 W

2.3.7 Connect the circuit as shown in Figure 3 below, with the motor windings (three phase load) connected in delta.

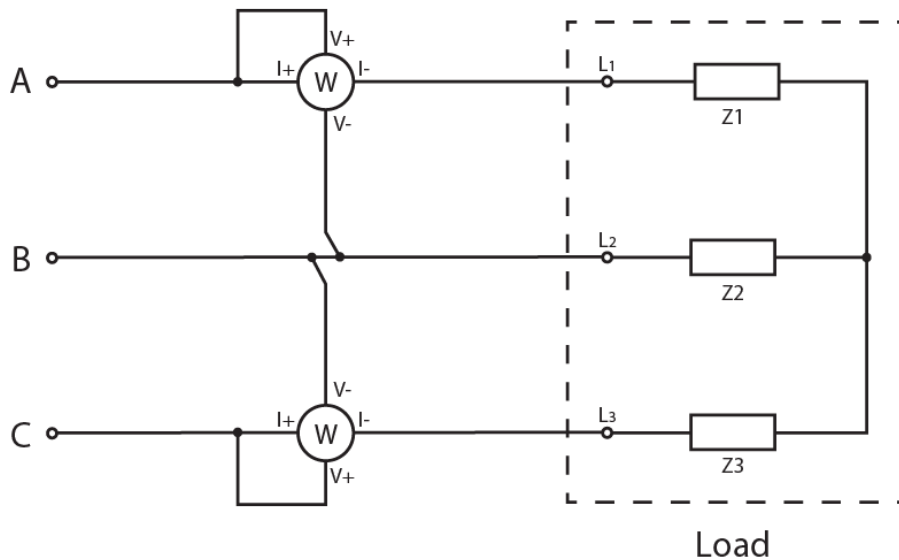





Figure 3

2.3.8 Measure the power using the two wattmeter method, and record your results in Table 3.

Table 3 – Two Wattmeter Method	
Wattmeter 1 (W_1)	Wattmeter 2 (W_2)

Topic Skills Practice 13.3

	 Feedback	Have your teacher/trainer check your work	Teacher/Trainer Initials and Date	

3. Completing the Skills Practice

3.1 Skills Practice Observations

3.1.1 Clean your work area, return all equipment to the correct storage areas as directed by your teacher/trainer, and then complete the following questions.

1. Use the results obtained in Table 1 to calculate the apparent power, the true power and the power factor when the motor is connected in star where:

- $S = (\sqrt{3})VI$
- $P_T = P_1 + P_2 + P_3$
- $\lambda = P/S$

$$\text{Apparent power} = \frac{42.3}{\sqrt{3}} \times 0.335 + \frac{42.3}{\sqrt{3}} \times 0.304 + \frac{42.3}{\sqrt{3}} \times 0.328 = 23.98 \text{ VA}$$

$$\text{True power (PT)} = 4.34 + 2.86 + 1.89 = 6.645 \text{ W}$$

$$\text{Power factor} = \frac{\text{True power}}{\text{Apparent power}} = \frac{6.645}{23.98} = 0.22$$

Apparent Power: 23.98 True Power: 6.645 Power Factor: 0.28

Topic Skills Practice 13.3

2. Use the results obtained in Table 2 to calculate the apparent power, the true power and the power factor when the motor is connected in delta. Use the same equations stated in Question 1.

$$\text{Apparent power} = \sqrt{3} EI = 1.7321 \times 42.3 \times = 58.6$$

$$\text{<or> } \frac{0.8}{\sqrt{3}} (42.3 + 42 + 42.3) = 58.6 \text{ VA}$$

$$\text{True Power} = 5.47 + 5.43 + 5.47 = 16.37$$

Apparent Power: 58.6 True Power: 16.37 Power Factor: 0.28

3. Calculate the delta to star ratios for current, apparent power and true power.

$$\Delta/Y \text{ VA Ratio} = \frac{58.6}{23.98} = 2.44$$

$$\text{Current Ratio} = \frac{0.8}{0.322} = 2.48$$

$$\text{Real Power Ratio} = \frac{16.37}{6.645} = 2.46$$

Current Ratio: 2.48

True Power Ratio: 2.46

Apparent Power Ratio: 2.44

4. Use the results obtained in Table 3 to calculate the power factor of the motor when the motor was connected in delta and the power was measured with the two wattmeter method.

Two wattmeter $\tan \phi = \frac{\sqrt{3} (W_1 - W_2)}{W_1 + W_2}$, $\phi = \tan^{-1} \frac{\sqrt{3} (W_1 - W_2)}{W_1 + W_2}$

But in this practical, three volt ~~one~~ meters method was used instead of 2 watt meter method

$P.F = \cos \phi$

Topic Skills Practice 13.3

Power Factor: _____

5. Compare the power factor obtained in Question 2 to that obtained in Question 4. How similar are the two values?

Not applicable

6. Use manufacturer's catalogues to select appropriate power, energy and power factor metering equipment for a 10 kW, 400 V star-connected motor circuit. Indicate the makes, models and types of equipment selected

OMEC motor 11kW | Schneider
 Efficiency class IE3 60034-307 | Electric
 Duty S1, Insulation class F | POWER METER
 Ingress protection IP55, IC411 cooling system | Power factor meter
 Pre lubricated ball bearings OMT1 & OMT2 series
 Frequency 50Hz



$$D = \frac{1.9 \times 10^7 \times K \times P_N}{m N \times FR}$$
 D = pulley diameter
 P_N = motor power (kW)
 m N = speed (rpm)
 K = 2.5 (V belt)
 FR = RADIAL FORCE (PERMISSIBLE)
 Permissible Radial & Axial Load

7. Use manufacturer's catalogues to select appropriate power factor correction equipment for a 50 kW 400 V delta-connected motor circuit. Indicate the make, model and type of equipment selected.

VERIS Energy VERIS E50 B1A kw/kwh power meter

Mounting DIN – RAIL	50-60 Hz
Display LCP	22-158 F(Operating Temperature)
Voltage range 90-600 V AC	Humidity range less than 95% RH
30 V AC/V DC 100 mA Maximum	

Topic Skills Practice 13.3

	 Feedback	Have your teacher/trainer check your answers	Teacher/Trainer Initials and Date	